

General Catalogue

mäder
pressen



Manual presses

Pneumatic presses

Hydropneumatic presses

Contents

mäder, the company

Press workstations

Special designs

Manual presses

- ▶ Accessories for manual presses
- ▶ Toggle presses with round ram
- ▶ Toggle presses with square ram
- ▶ Rack and pinion presses with round ram
- ▶ Rack and pinion presses with square ram
- ▶ MicroPress® with round ram
- ▶ Process monitoring for manual presses

Pneumatic presses

- ▶ Pneumatic toggle presses
- ▶ Manually assisted pneumatic toggle presses
- ▶ Direct acting pneumatic presses
- ▶ DAP Portal Press
- ▶ DAF Direct acting press cylinders
- ▶ MicroPress® with square ram
- ▶ Hydropneumatic presses
- ▶ Slide tables
- ▶ Press heads
- ▶ Standard controllers
- ▶ Process monitoring for pneumatic presses

Press & Tool Concept

- ▶ Press/tool overview
- ▶ KP 2.1 Hand-operated toggle presses
- ▶ KP 3.1 Pneumatic presses
- ▶ Tool systems

mäder presses, the applications

A number of processes can be performed quickly, precisely and easily with mäder presses.

For example:

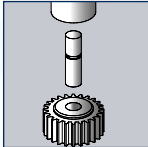
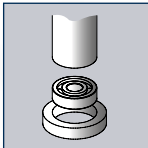
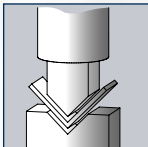
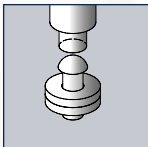
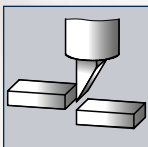
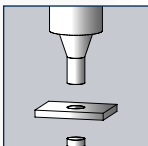
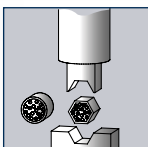
3		
4		
5		
7		Assembly
8-11		
12-15		Pressing
16-17		
18-19		
20-21		
22-25		Bending
26-29		
30-31		Riveting
32-45		
46-47		
48-49		
50-51		Edge cutting
52-55		
56-57		
58		
59		Punching
60-63		
64		
65		Crimping
66-67		
68-69		
70-71		

We would be happy to determine the press force required based on your parts.



As a medium-sized company, **mäder pressen** has been manufacturing manual and pneumatic table presses since the middle of the 1960s and from the very beginning has been a watchword for innovation, flexibility and reliability. Today, modern assembly presses are produced with high quality in our factory by qualified staff.

mäder pressen are active throughout the world and are represented in many countries with their own staff, agencies and partners.

mäder, the products

mäder presses are extensively used in all branches of the non-machining manufacturing industry, in particular in assembly, light engineering and electrical engineering and wherever precision and reliability are important. Special solutions represent a challenge for our team which we are only too pleased to accept.

Ultimately responsible for the high quality of the mäder press range are our qualified staff of many years standing, our in-depth manufacturing capability, and production on modern CNC machining centres.

Our presses are manufactured in accordance with the relevant EN norms. The controllers are type-tested by TÜV Süd in accordance with the latest issue of the EC Machinery Directive 2006/42/EC and are therefore CE compliant.

All these factors enable the quality of our products to be extensively monitored and are a decisive factor in helping our customers to success.

With a combination of different press components and equipment options, **mäder** presses always provide excellent value for money. In this way, mäder presses enable high flexibility and efficiency in production.

Ongoing development of our products also guarantees our customers a path to the future. Detailed improvements which increase both the technical quality and ergonomics of our presses continuously flow into our current production. New designs reflecting our customers' requirements are regularly introduced.

Special designs and customer-specific modifications of existing models can often be provided on request.

Contact us for more information.

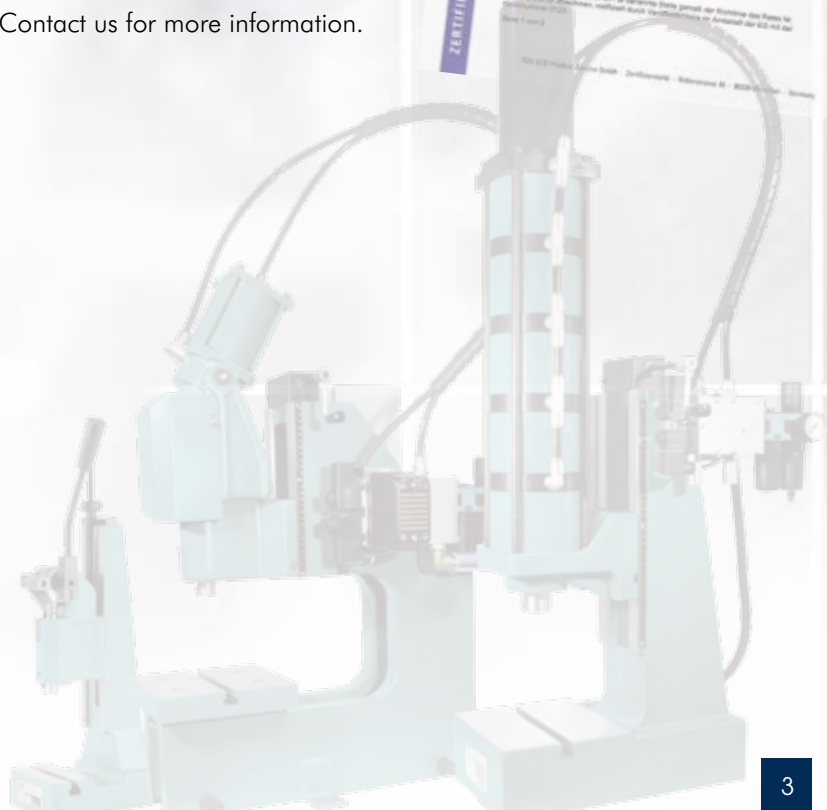

As well as presses, **mäder** also offers the design and construction of complete workstations. **mäder** presses are therefore able to satisfy today's requirements for flexible working means which can be quickly adapted to suit an ever increasing range of models in smaller batches and with shorter production cycles.

Flexible manual workstations which are designed to customers' requirements mean a reasonable investment. Our pictures of practical applications show some of the many possible solutions.



Colours

- ▶ Standard colour RAL 5021 or RAL 7035 on request at no extra cost
- ▶ Special RAL colours at extra cost



RAL 5021

RAL 7035

Special colour

Special models

In spite of the large number of standard presses, there are applications where it is necessary to modify existing models in order to optimise the manufacturing process or to make manufacturing possible at all. **mäder pressen** design and produce these special models in agreement with you.

- ▶ Cleanroom models in different designs to customers' specifications
- ▶ Extended daylight or throat
- ▶ User-specific special functions



Example: Cleanroom design
Cast parts chemically nickel-plated, other parts stainless steel

A small selection of modified presses

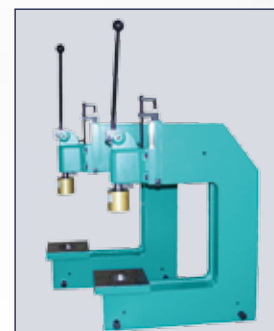
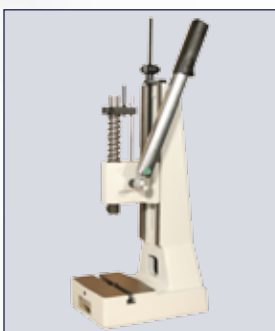
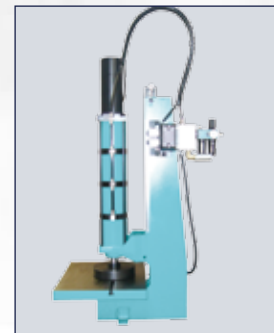

Capacity range: from 1.5 kN to 30 kN

Manual presses provide great economy for production processes and batch sizes which require no automation. They can be used quickly and flexibly in such applications.

mäder produces two types of manual presses with different force characteristics: toggle presses and rack and pinion presses. All **mäder** manual presses can be provided with round or square rams.

Quality features

- ▶ Factory-set pressure point
- ▶ Simple and rapid adjustment of the height of the press head using a threaded spindle
- ▶ Hardened and ground ram
- ▶ Long, honed and therefore high-precision round ram guide
- ▶ High-accuracy square ram guide by means of adjustable jib strips
- ▶ Ground press table
- ▶ **mäder** manual presses are virtually maintenance-free



Example: Height-adjustable press head

ERGO hand lever for all mäder hand-operated presses



The ERGO hand lever for mäder hand-operated presses improves their ergonomics. The horizontal and rotatable hand lever permits operation of the press without fully grasping it, and so increases the ease of use.

If your hand-operated press is to remain mobile



The hand-operated press fastened to a practical baseplate stands firm and does not tilt. Rubber stoppers prevent it from slipping. Two movable threaded inserts can be adjusted to the distance between the fixing holes of the press.



Example: Toggle press



Example: Rack and pinion press

Pictograms in the catalogue show which accessories are possible for which presses.

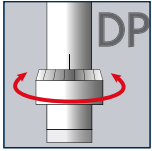

Precision ram adjustment (DP)

As toggle presses do not achieve their maximum force until BDC, adjusting the height of the press head by means of the threaded spindle is often too inaccurate. The precision ram adjustment enables the press pressure point to be precisely set directly at the ram. The scale on the adjustment ring enables the fine setting to be read off to 0.02 mm. The adjustment range is ± 1.5 mm. The precision ram adjustment is used when the utmost precision is required for the press depth. Ideal for prototype manufacture and serial production when accurate and easy adjustment within the tolerance range is required.



Micrometer stop (MICRO)

The micrometer stop is used with rack and pinion presses for high-precision assembly work or for when the tool has to be accurately positioned. This enables the press stroke length to be accurately adjusted to 0.01 mm

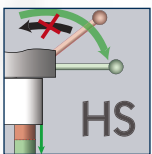

Return travel lock (HS)

The return travel lock for toggle and rack and pinion presses is an effective contribution to quality assurance during production. The return travel lock rules out partial strokes and therefore incomplete operations. Forming, assembly and joining operations are always reliably and completely executed, as the return stroke of the press is blocked on the downward stroke. The interlock is only released and the lever can only be returned when the stroke is complete. The Quick-Release mechanism enables this inhibit to be released and jammed parts to be removed in any position. The Quick-Release is automatically deactivated when the lever is returned.

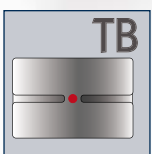
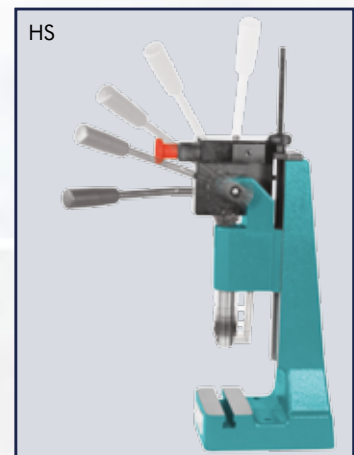
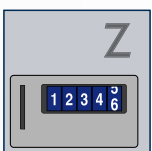
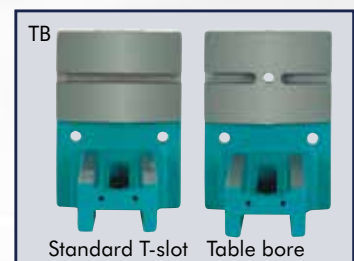

Table bore (TB)

The bottom part of the tool can be mounted in the centric table bore. Fixing is by means of a transverse screw in all models up to 80 mm throat. The table bore enables the tool to be changed quickly and reduces set-up time. The alignment accuracy of the ram bore with the table bore is < 0.05 mm.



Stroke counter (Z)

A rapid overview of the number of items produced can be obtained with the five-digit stroke counter. The number of items can be reset.



The accessories

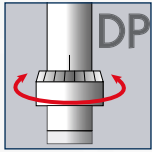

Manual toggle presses with round ram EP range

EP Type toggle presses in 5 kN, 7.5 kN and 12 kN sizes are designed for serial or individual manufacture in manual workstations. As the nominal end force is produced at the end of the stroke, a large force can be exerted at the exact point it is required. The manual force of 120 N to be applied is user-friendly. As many applications require less force, fatigue-free working is possible even with serial production.

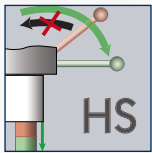

ERGOPRESS® hand lever

- ▶ Ergonomic user comfort.
- ▶ 360° stepless adjustment
- ▶ Lever angled to the side: free view of work area and ergonomically comfortable position.
- ▶ Simple and easy conversion for left-handers (except HS and Z option) without losing the tool setting. Ideal for job sharing on one press.

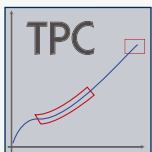
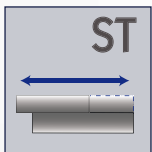
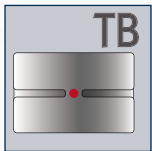
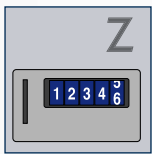

Manual lever can be refitted for right and left-handers

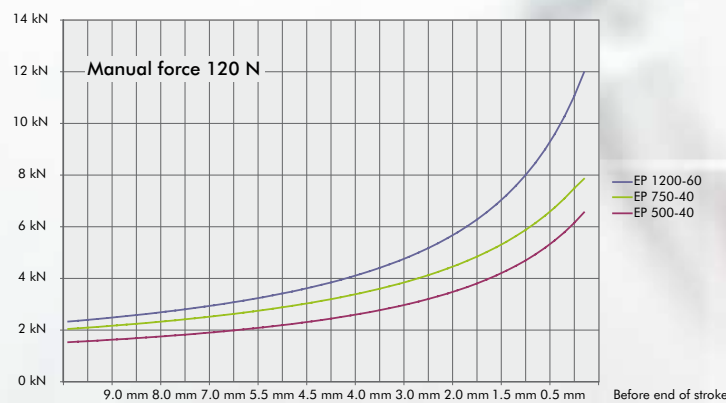

Standard

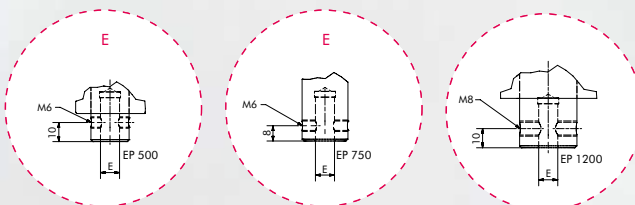

With DP

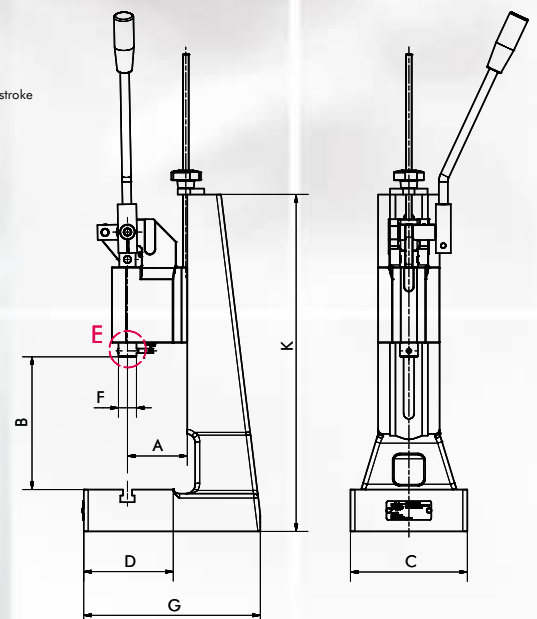
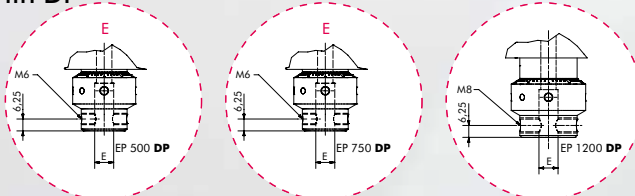

EP range
L-EP range with extra large daylight

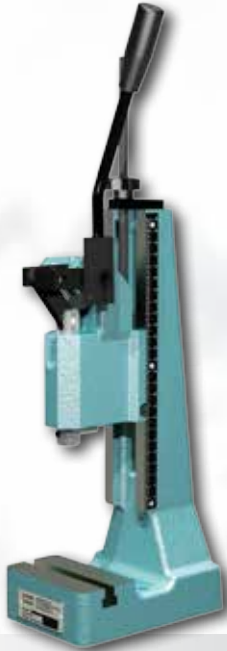

EP 500-40



EP 750-40



L-EP 1200-60

with accessories
DP - Precision ram adjustment
HS - Return travel lock
equipped with ERGO hand lever*

mader toggle presses

Type			EP 500-40	EP 750-40	L-EP 750-40	EP 1200-60	L-EP 1200-60
Capacity		kN	5.0	7.5	7.5	12.0	12.0
Working stroke		mm	40	40	40	60	60
Throat	A	mm	63	80	80	80	80
Daylight	B	mm	40 - 213	58 - 265	55 - 375	62 - 240	75 - 338
Daylight with DP	B	mm	20 - 197	38 - 250	39 - 359	48 - 231	53 - 328
Table size	CxD	mm	110 x 65	157 x 115	156 x 115	157 x 115	157 x 115
T-slot width similar to DIN 650		mm	10	12	12	12	12
Ram bore Ø x Depth	E	mm	10 ^{H7} x 25	10 ^{H7} x 25	10 ^{H7} x 25	10 ^{H7} x 30	10 ^{H7} x 30
Ram bore Ø x Depth with DP	E	mm	10 ^{H7} x 25	10 ^{H7} x 25	10 ^{H7} x 25	10 ^{H7} x 25	10 ^{H7} x 25
Ram Ø	F	mm	20	24	24	30	30
Space requirement	CxG	mm	110 x 164	157 x 237	156 x 275	157 x 237	156 x 275
Stand height	K	mm	355	450	570	450	570
Weight		kg	ca. 10	ca. 20	ca. 28	ca. 24	ca. 32

Accessories (see Page 7)	Please specify when ordering.				
Precision ram adjustment	DP	DP	DP	DP	DP
Return travel lock	HS	HS	HS	HS	HS
Counter	Z	Z	Z	Z	Z
Table bore 12 ^{H7}	TB	TB	TB	TB	TB

*Not included. Accessories must be ordered separately.

The accessories

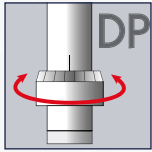

APK T range

The extra-powerful hand-operated toggle presses of the APK T 3 and APK T 4 ranges are especially suitable for the frequently changing applications in modelmaking and in the workshop. Their high forces of up to 30 kN enable them to be flexibly used for widely differing applications.

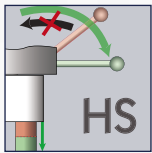

The advantages:

- ▶ Choice of different stroke lengths
- ▶ Extra-stable press base design
- ▶ Daylight easily adjustable by means of the standard press head threaded spindle height adjustment
- ▶ The nominal force of the press can be achieved with moderate applied force

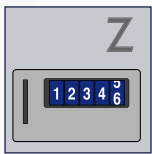

XL-APKT range with 250 mm throat

A larger throat is required wherever bulky parts are processed, e.g. the processing of printed circuit boards, sheet metal and similar parts. **mäder** XL presses with 250 mm throat are employed in such cases. The base is a stable welded structure to which different standard press heads can be fitted.

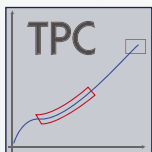
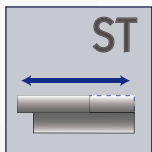
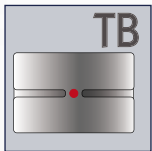

Standard

With DP

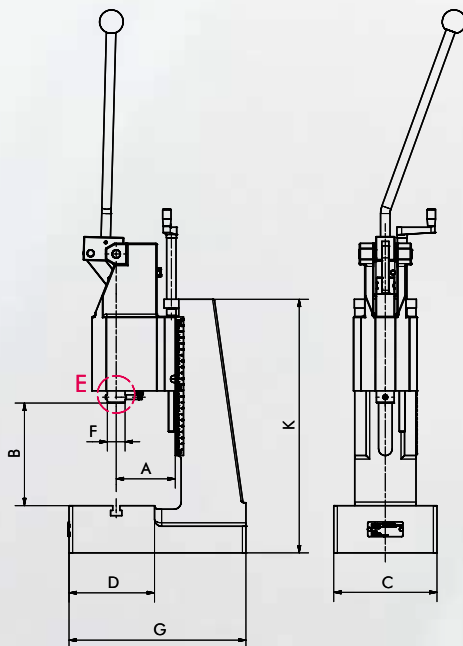
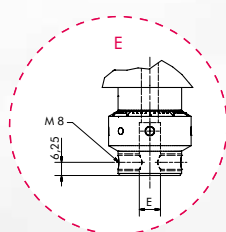
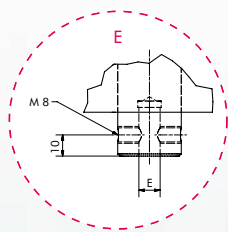

XL models

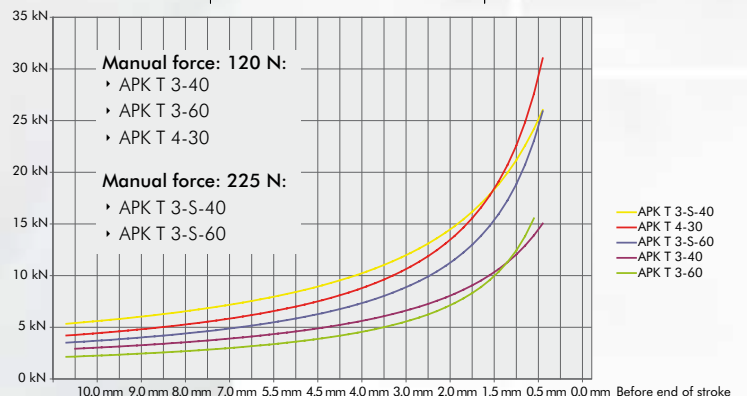
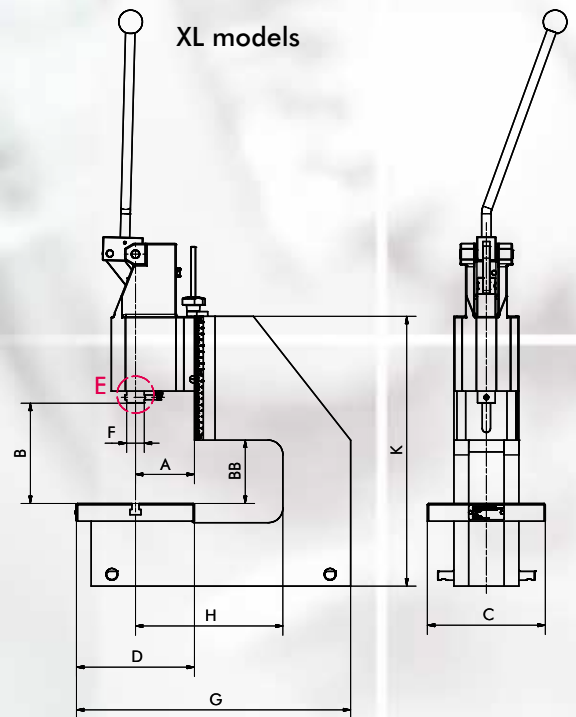

APK T range XL-APK T range with 250 mm throat



Toggle presses

APK T 3-40

equipped with ERGO hand lever*

APK T 3-S-60

XL-APK T 3-40

Type			APK T3-40	APK T3-60	APK T3-S-40	APK T3-S-60	APK T4-30	XL-APK T3-40	XL-APK T3-60
Capacity		kN	15.0	15.0	25.0	25.0	30.0	15.0	15.0
Working stroke		mm	40	60	40	60	30	40	60
Throat	A	mm	100	100	100	100	100	100	100
Throat C-frame	H	mm	-	-	-	-	-	250	250
Daylight	B	mm	49 - 168	51 - 172	60 - 290	65 - 295	55 - 285	88 - 166	90 - 168
Daylight with DP	B	mm	35 - 154	30 - 151	46 - 274	44 - 274	34 - 264	72 - 150	69 - 147
Daylight C-frame	BB	mm	-	-	-	-	-	100	100
Table size	CxD	mm	175 x 140	175 x 140	185 x 145	185 x 145	185 x 145	200 x 200	200 x 200
T-slot width similar to DIN 650		mm	12	12	12	12	12	12	12
Ram bore Ø x Depth	E	mm	10 ^{H7} x 30	10 ^{H7} x 30	10 ^{H7} x 30	10 ^{H7} x 30	10 ^{H7} x 30	10 ^{H7} x 30	10 ^{H7} x 30
Ram bore Ø x Depth with DP			10 ^{H7} x 25	10 ^{H7} x 25	10 ^{H7} x 25	10 ^{H7} x 25	10 ^{H7} x 25	10 ^{H7} x 25	10 ^{H7} x 25
Ram Ø	F	mm	30	30	30	30	30	30	30
Space requirement	CxG	mm	175 x 300	175 x 300	185 x 320	185 x 320	185 x 320	200 x 465	200 x 465
Stand height	K	mm	425	425	520	520	520	465	465
Weight		kg	ca. 39	ca. 43	ca. 58	ca. 63	ca. 63	ca. 54	ca. 58

Accessories (see Page 7)	Please specify when ordering.								
Precision ram adjustment		DP	DP	DP	DP	DP	DP	DP	DP
Return travel lock		HS	HS	HS	HS	HS	HS	HS	HS
Counter		Z	Z	Z	Z	Z	Z	Z	Z
Table bore 12 ^{H7}		TB	TB	TB	TB	TB	TB	TB	TB

*Not included. Accessories must be ordered separately.

The accessories

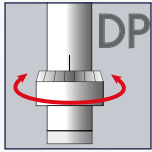

The square ram has significant advantages compared with the round ram:

- ▶ Absolute protection against twisting
- ▶ Hardened and precisely ground ram
- ▶ Press ram guide free from play
- ▶ Readjustable jib strips for square ram
- ▶ Large tool locating surface
- ▶ Guides in tool therefore usually unnecessary
- ▶ Practically maintenance-free operation

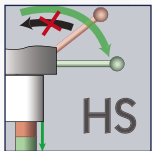

mäder hand-operated toggle presses with square ram are ideal tools for manufacturing small precision parts with tight tolerances in small and medium-sized batches where automation would be too cost-intensive.

ERGOPRESS® hand lever

- ▶ Ergonomic user comfort.
- ▶ 360° stepless adjustment
- ▶ Lever angled to the side: free view of work area and ergonomically comfortable position.
- ▶ Simple and easy conversion for left-handers (except HS and Z option) without losing the tool setting. Ideal for job sharing on one press.

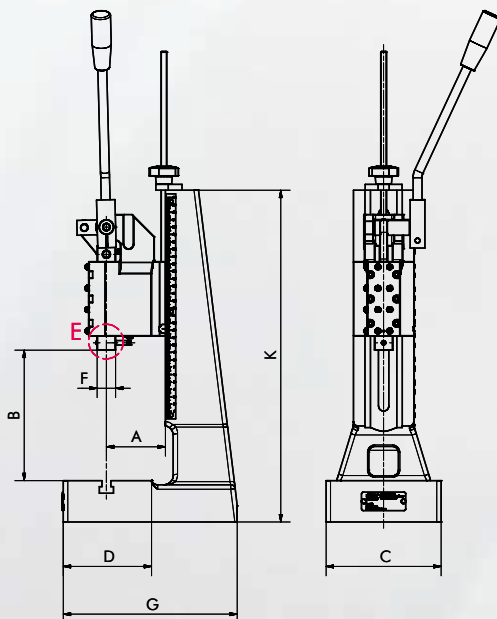
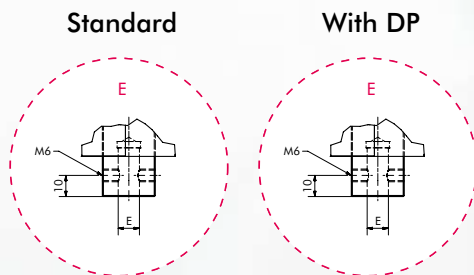
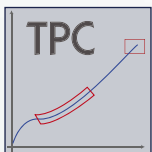
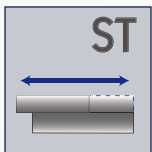
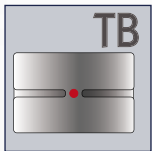
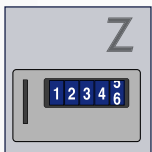

Manual lever can be refitted for right and left-handers

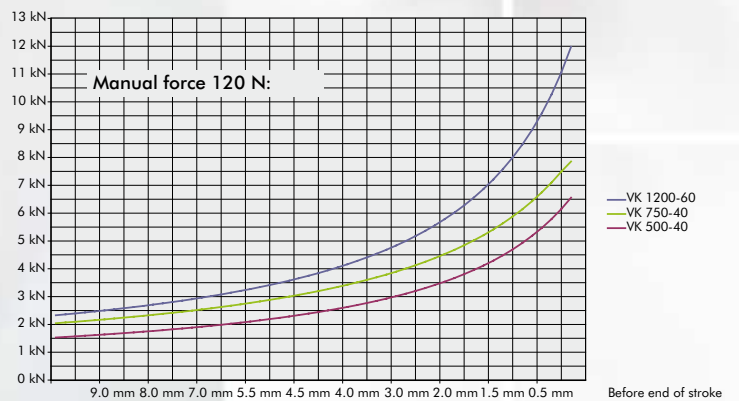

VK range L-VK range with extra large daylight

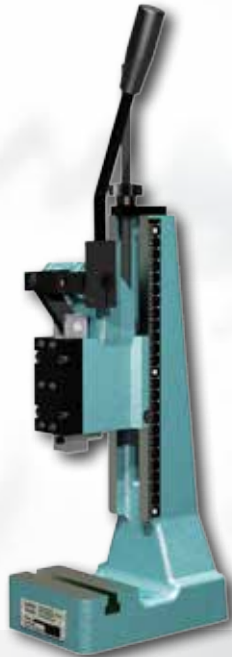

VK 500-40

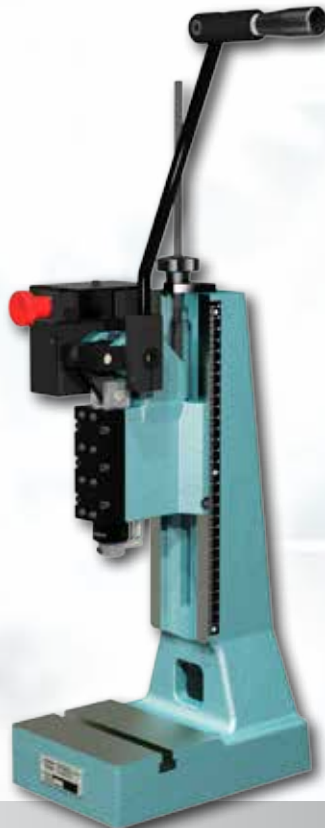

VK 750-40



L-VK 1200

with accessories
 DP - Precision ram adjustment
 HS - Return travel lock
 equipped with ERGO hand lever*

Toggle presses

Type			VK 500-40	VK 750-40	L-VK 750-40	VK 1200-60	L-VK 1200-60
Capacity		kN	5.0	7.5	7.5	12.0	12.0
Working stroke		mm	40	40	40	60	60
Throat	A	mm	63	80	80	80	80
Daylight	B	mm	40 - 213	53 - 265	55 - 375	45 - 245	52 - 338
Daylight with DP	B	mm	25 - 197	38 - 250	39 - 359	31 - 231	38 - 328
Table size	CxD	mm	110 x 65	157 x 115	157 x 115	157 x 115	157 x 115
T-slot width similar to DIN 650		mm	10	12	12	12	12
Ram bore Ø x Depth	E	mm	10 ^{H7} x 25	10 ^{H7} x 25	10 ^{H7} x 25	10 ^{H7} x 30	10 ^{H7} x 30
Ram bore Ø x Depth with DP	E	mm	10 ^{H7} x 25	10 ^{H7} x 25	10 ^{H7} x 25	10 ^{H7} x 25	10 ^{H7} x 25
Ram area	F	mm	21 x 21	25 x 25	25 x 25	31 x 31	31 x 31
Space requirement	CxG	mm	110 x 164	155 x 237	156 x 275	155 x 237	156 x 275
Stand height		mm	355	450	570	450	570
Weight		kg	ca. 10	ca. 20	ca. 28	ca. 24	ca. 32

Accessories (see Page 7)	Please specify when ordering.				
Precision ram adjustment	DP	DP	DP	DP	DP
Return travel lock	HS	HS	HS	HS	HS
Counter	Z	Z	Z	Z	Z
Table bore 12 ^{H7}	TB	TB	TB	TB	TB

*Not included. Accessories must be ordered separately.

The accessories

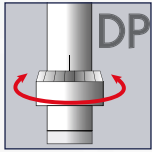

VK range

The extra-powerful hand-operated toggle presses of the VK range are especially suitable for the frequently changing applications in modelmaking and in the workshop. Their high forces of up to 30 kN enable them to be flexibly used for widely differing applications.

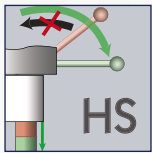

The advantages:

- ▶ Choice of different stroke lengths
- ▶ Extra-stable press base design
- ▶ Daylight easily adjustable by means of the standard press head threaded spindle height adjustment
- ▶ The nominal force of the press can be achieved with moderate applied force

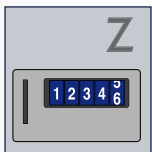

XL-VK range with 250 mm throat

A larger throat is required wherever bulky parts are processed, e.g. the processing of printed circuit boards, sheet metal and similar parts. mäder XL presses with 250 mm throat are employed in such cases. The base is a stable welded structure to which different standard press heads can be fitted.

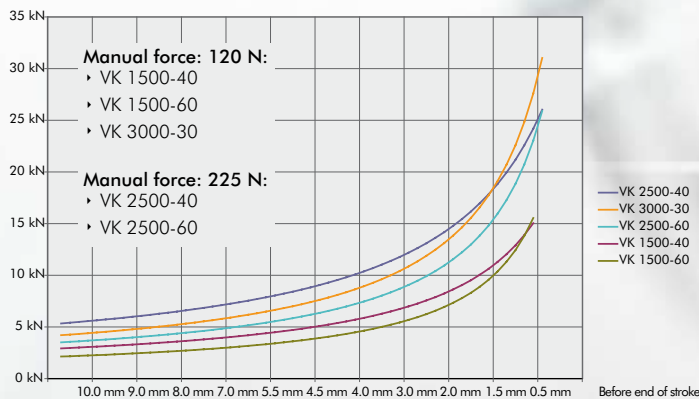
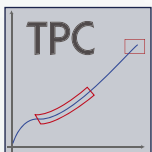
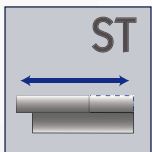
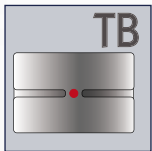

XL models

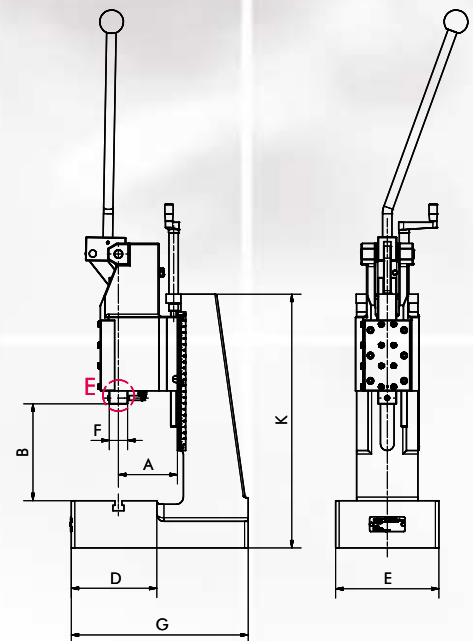
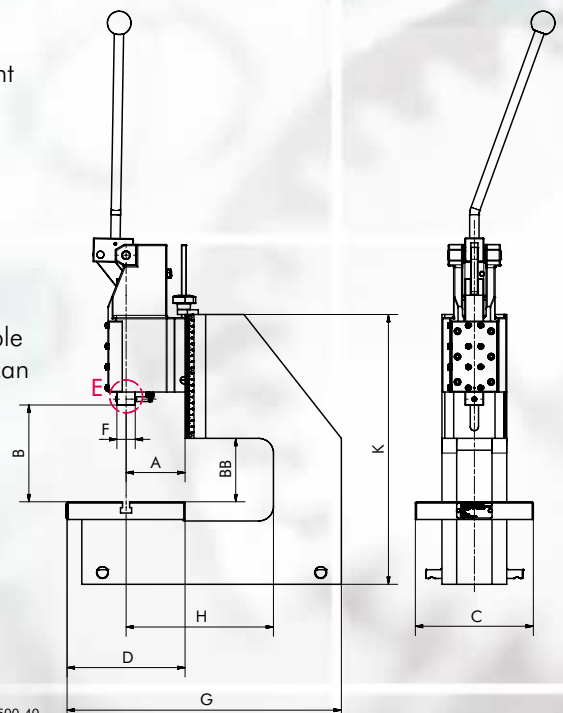

Standard

With DP

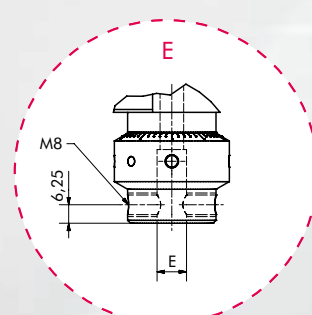
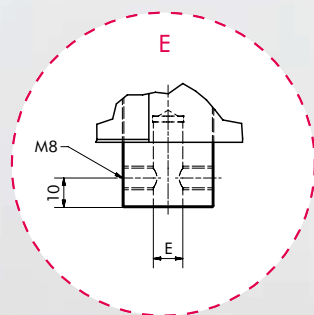

VK range
XL-VK range with 250 mm throat



VK 1500-40

equipped with ERGO hand lever*

VK 2500-60

XL-VK 1500-40

Toggle presses

Type		VK 1500-40	VK 1500-60	VK 2500-40	VK 2500-60	VK 3000-30	XL-VK 1500-40	XL-VK 1500-60
Capacity	kN	15.0	15.0	25.0	25.0	30.0	15.0	15.0
Working stroke	mm	40	60	40	60	30	40	60
Throat	A mm	100	100	100	100	100	100	100
Throat C-frame	H mm	-	-	-	-	-	250	250
Daylight	B mm	49 - 168	49 - 168	60 - 290	65 - 295	65 - 295	80 - 166	88 - 166
Daylight with DP	B mm	35 - 154	35 - 154	46 - 274	44 - 274	44 - 274	72 - 150	72 - 150
Daylight C-frame	BB mm	-	-	-	-	-	100	100
Table size	CxD mm	175 x 140	175 x 140	185 x 145	185 x 145	185 x 145	200 x 200	200 x 200
T-slot width similar to DIN 650	mm	12	12	12	12	12	12	12
Ram bore Ø x Depth	E mm	10 ^{H7} x 30	10 ^{H7} x 30	10 ^{H7} x 30	10 ^{H7} x 30	10 ^{H7} x 30	10 ^{H7} x 30	10 ^{H7} x 30
Ram bore Ø x Depth with DP	E mm	10 ^{H7} x 25	10 ^{H7} x 25	10 ^{H7} x 25	10 ^{H7} x 25	10 ^{H7} x 25	10 ^{H7} x 25	10 ^{H7} x 25
Ram area	F mm	31 x 31	31 x 31	31 x 31	31 x 31	31 x 31	31 x 31	31 x 31
Space requirement	CxG mm	175 x 300	175 x 300	185 x 320	185 x 320	185 x 320	200 x 465	200 x 465
Stand height	K mm	425	425	520	520	520	465	465
Weight	kg	ca. 39	ca. 43	ca. 58	ca. 63	ca. 63	ca. 55	ca. 59

Accessories (see Page 7)	Please specify when ordering.							
Precision ram adjustment	DP	DP	DP	DP	DP	DP	DP	DP
Return travel lock	HS	HS	HS	HS	HS	HS	HS	HS
Counter	Z	Z	Z	Z	Z	Z	Z	Z
Table bore 12 ^{H7}	TB	TB	TB	TB	TB	TB	TB	TB

*Not included. Accessories must be ordered separately.

The accessories



APZ range, L-APZ range with extra large daylight

mäder rack and pinion presses transmit their force constantly over the whole stroke length. The direct transmission of force via the manual lever allows fine control. Rack and pinion presses are therefore used where a constant force characteristic over a longer stroke is required.

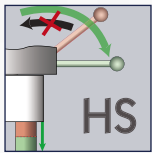

Manual lever with ergonomic user comfort

- ▶ Can be turned through 360°: adaptable for any body size and application.
- ▶ Lever angled to the side: free view of work area and ergonomically comfortable position.
- ▶ **R/L Version:** simple and easy conversion for left-handers without losing the tool setting. Ideal for job sharing on one press.

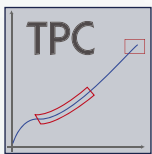
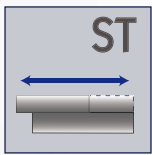
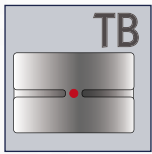
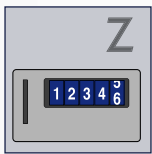

Manual lever can be refitted for right and left-handers

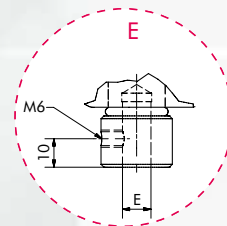
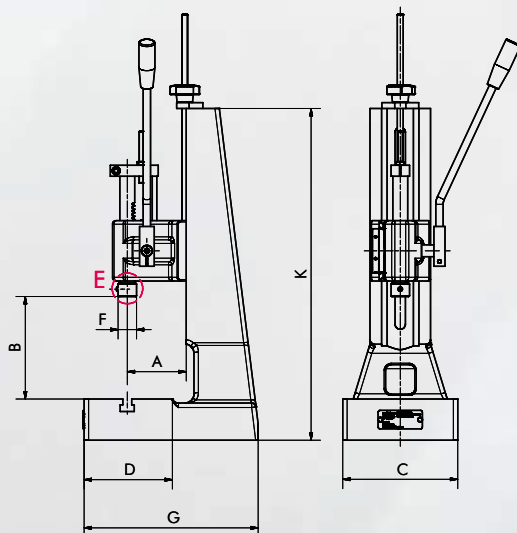
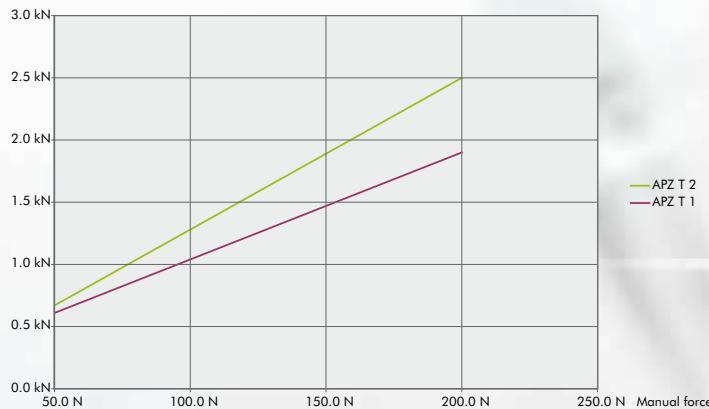

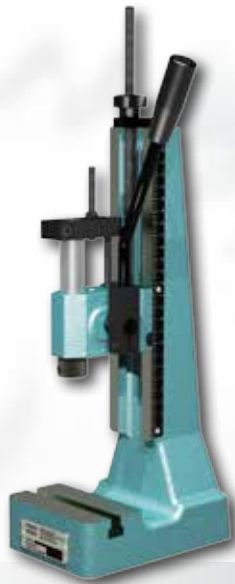

APZ T 1-40

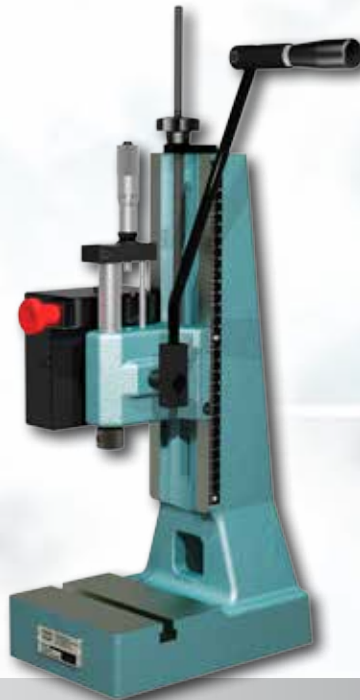

APZ T 2-50



L-APZ T 2-50

with accessories
DP - Precision ram adjustment
MICRO - Micrometer stop
equipped with ERGO hand lever**

Type			APZ T1-40	APZ T1-90	APZ T2-50	APZ T2-100	L-APZ T2-50	L-APZ T2-100
Capacity		kN	1.5	1.5	2.5	2.5	2.5	2.5
Working stroke		mm	40	90	50	100	50	100
Throat	A	mm	63	63	80	80	80	80
Daylight	B	mm	40 - 235	40 - 235	42 - 290	42 - 290	55 - 390	55 - 390
Table size	CxD	mm	110 x 65	110 x 65	157 x 115	157 x 115	157 x 115	157 x 115
T-slot width similar to DIN 650		mm	10	10	12	12	12	12
Ram bore Ø x Depth	E	mm	10 ^{H7} x 25	10 ^{H7} x 25	10 ^{H7} x 25	10 ^{H7} x 25	10 ^{H7} x 25	10 ^{H7} x 25
Ram Ø	F	mm	25	25	25	25	25	25
Space requirement	CxG	mm	110 x 164	110 x 164	157 x 237	157 x 237	156 x 275	156 x 275
Stand height	K	mm	355	355	450	450	570	570
Weight		kg	ca. 8.5	ca. 8.5	ca. 21	ca. 21	ca. 29	ca. 29

Accessories (see Page 7)	Please specify when ordering.						
Return travel lock	HS	HS	HS	HS	HS	HS	HS
Micrometer stop	MICRO	MICRO	MICRO	MICRO	MICRO	MICRO	MICRO
Counter	Z	Z	Z	Z	Z	Z	Z
Table bore 12 ^{H7}	TB	TB	TB	TB	TB	TB	TB
Left/right-hander version*	R/L	R/L	R/L	R/L	R/L	R/L	R/L

*Can only be combined with the MICRO and TB accessories.

**Not included. Accessories must be ordered separately.

The accessories

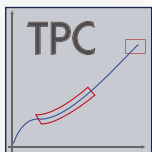
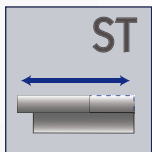
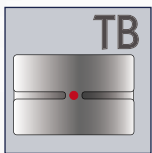
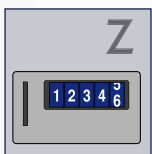
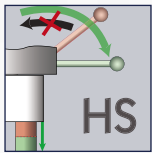

VZ range, L-VZ range with extra large daylight

The square ram has significant advantages compared with the round ram:

- ▶ Absolute protection against twisting
- ▶ Press ram guide free from play
- ▶ Readjustable guide rails for square ram
- ▶ Large tool locating surface
- ▶ Guides in tool therefore usually unnecessary
- ▶ Practically maintenance-free operation

mäder rack and pinion presses with square ram are ideal tools for manufacturing small precision parts with tight tolerances in small and medium-sized batches where automation would be too cost-intensive.

Manual lever with ergonomic user comfort

- ▶ Can be turned through 360°: adaptable for any body size and application.
- ▶ Lever angled to the side: free view of work area and ergonomically comfortable position.
- ▶ **R/L Version:** simple and easy conversion for left-handers without losing the tool setting. Ideal for job sharing on one press.



Manual lever can be refitted for right- and left-handers

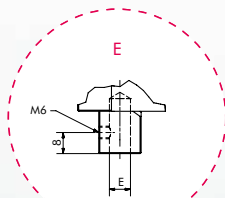

VZ 150

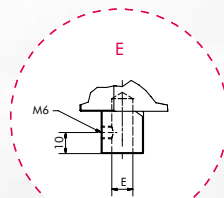

VZ 250

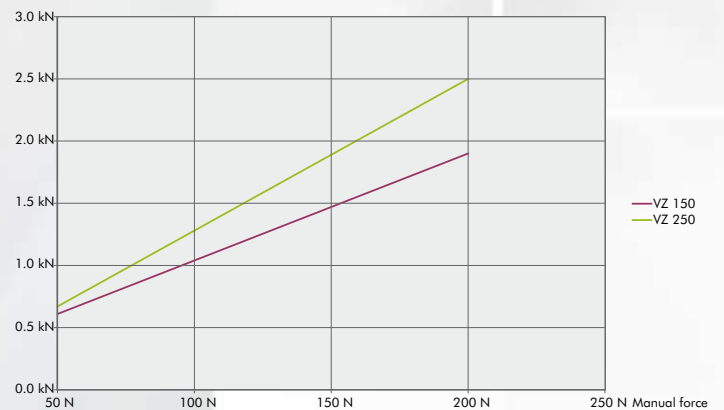
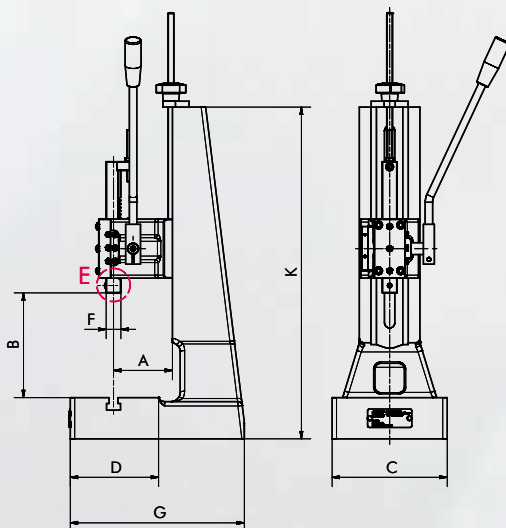

VZ Series L-VZ Series with extra large daylight

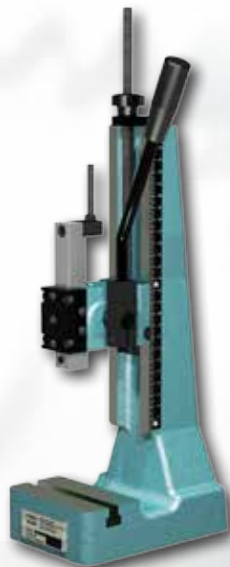

VZ 150-40



VZ 250-50

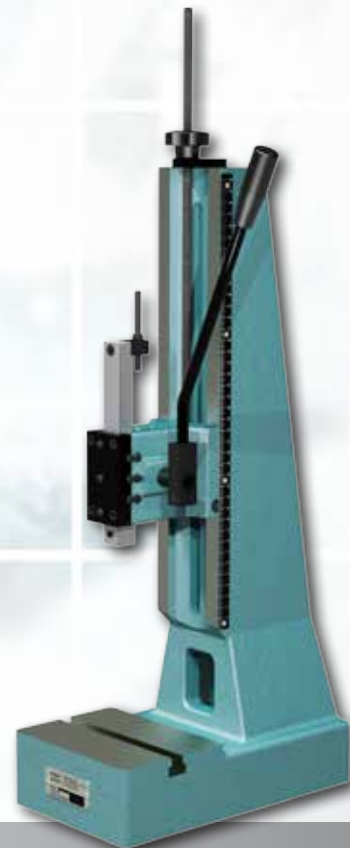

L-VZ 250-50

with extras
HS - Return travel lock
MICRO - Micrometer stop
equipped with ERGO hand lever**

Type			VZ 150-40	VZ 150-90	VZ 250-50	VZ 250-100	L-VZ 250-50	L-VZ 250-100
Capacity		kN	1.5	1.5	2.5	2.5	2.5	2.5
Working stroke		mm	40	90	50	100	50	100
Throat	A	mm	63	63	80	80	80	80
Daylight	B	mm	35 - 235	35 - 235	42 - 290	42 - 290	55 - 390	55 - 390
Table size	CxD	mm	110 x 65	110 x 65	157 x 115	157 x 115	157 x 115	157 x 115
T-slot width similar to DIN 650		mm	10	10	12	12	12	12
Ram bore Ø x Depth	E	mm	10 ^{H7} x 25	10 ^{H7} x 25	10 ^{H7} x 25	10 ^{H7} x 25	10 ^{H7} x 25	10 ^{H7} x 25
Ram Ø	F	mm	20 x 20	20 x 20	20 x 20	20 x 20	20 x 20	20 x 20
Space requirement	CxG	mm	110 x 164	110 x 164	157 x 237	157 x 237	156 x 275	156 x 275
Stand height	K	mm	355	355	450	450	570	570
Weight		kg	ca. 8.5	ca. 8.5	ca. 21	ca. 21	ca. 29	ca. 29

Accessories (see Page 7)	Please specify when ordering.						
Return travel lock	HS	HS	HS	HS	HS	HS	HS
Micrometer stop	MICRO	MICRO	MICRO	MICRO	MICRO	MICRO	MICRO
Counter	Z	Z	Z	Z	Z	Z	Z
Table bore 12 ^{H7}	TB	TB	TB	TB	TB	TB	TB
Left/right-hander version*	R/L	R/L	R/L	R/L	R/L	R/L	R/L

The accessories

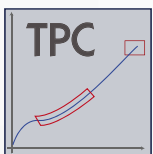
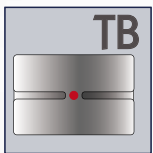
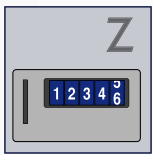
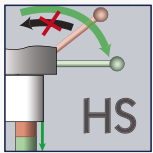

The MicroPress® rack and pinion press is particularly suitable for precise fitting work in light engineering, where the force needed is low but where the operator wants to work sensitively.

The advantages:

- ▶ Press table with T-slot as standard in scope of supply
- ▶ Alternatively, press tables with table bore TB or in flat version or to customer specification can be supplied.
- ▶ Quickly and easily converted from right-handed to left-handed operation.
- ▶ Adjustable daylight
- ▶ Precise guidance of ram
- ▶ Cushioned return stroke
- ▶ Stroke length adjustable
- ▶ Hand lever adjustable over 360°
- ▶ Lightweight design

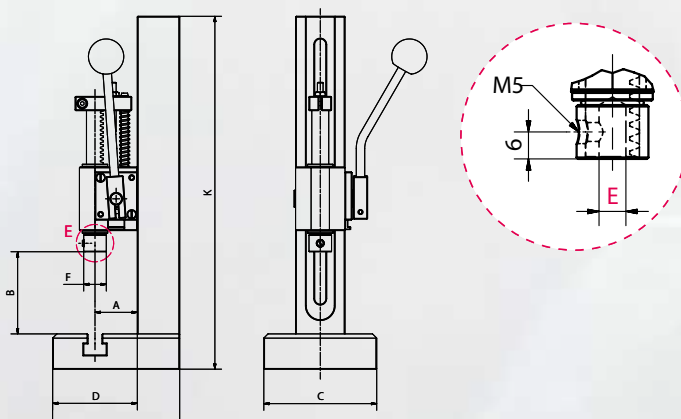
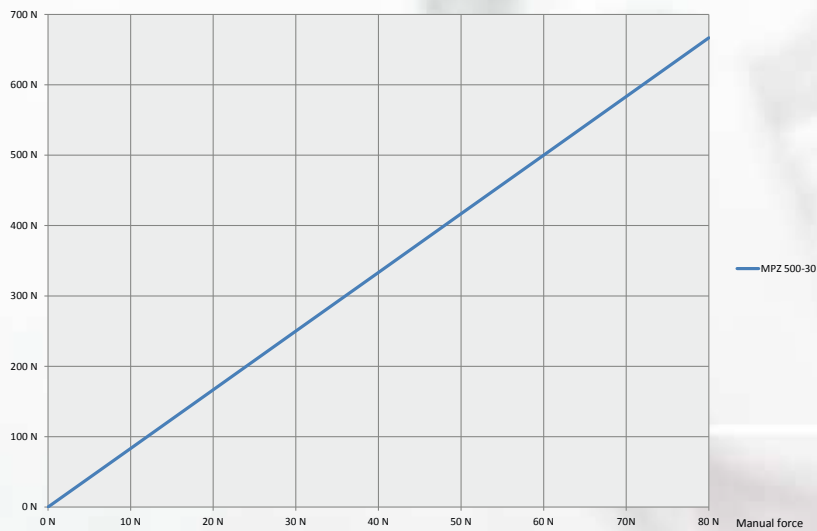



Standard

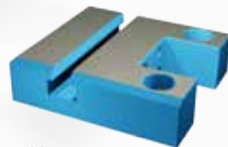
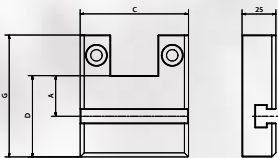

Table 1

Accessories*

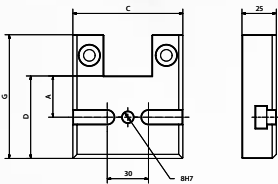

Table 2

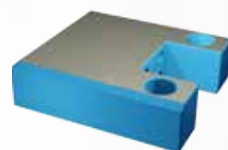
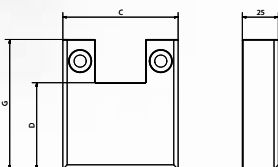

Table 3

Type			MPZ 500-30
Capacity		N	500
Working stroke		mm	25
Throat	A	mm	30
Daylight	B	mm	25 - 150
Table size	CxD	mm	60 x 80
Ram bore Ø x Depth	E	mm	6H7 x 12
Ram Ø	F	mm	16
Space requirement	CxG	mm	90 x 80
Stand height		mm	250
Weight		kg	ca. 1.5
Tabletop			
Table 1 T-slot width similar to DIN 650		mm	10
Table 2 T-slot with TB		mm	8H7
Table 3 plan			

*Not included. Accessories must be ordered separately.

Low-cost monitoring and logging of pressing processes with mäder hand presses.



- Can be fitted to all mäder hand presses
- Intelligent sensors, automatic recognition of sensor values
- Auto-configuration of the measurement program with the master-card
- Easy, one-button operation
- 2 line, easy read display
- Bright OK /NOK displays
- Adjustable alarm tone
- Diverse counter functions
- One channel measurement (force only) possible

Options:

- Measurement logging via USB interface
- Tool card for storing and setting tool-specific measurement data
- Cam PLC operation
- PLC card for storing and setting programs.



The TPC ForceMaster can be set up quickly and easily:

Sensor detection

The connectors of the force and displacement sensors are not interchangeable, and are therefore protected from false connections. The characteristics of the sensor are already stored on a printed circuit board in the connector plug. When the TPC ForceMaster is switched on, the sensors are automatically detected and the zero point determined. If the sensors are exchanged, the sensor change will be shown in the display and must be confirmed.

Auto-configuration

The TPC ForceMaster creates a process monitoring proposal, based on a one-time teach-in process of a good part. This proposal can either be accepted or modified manually on the device or with the help of the supplied software. A good part consists of parts which were checked before the pressing process as to whether they are within the manufacturing tolerances and from which it can therefore be expected that the process will in turn manufacture a good part.

Evaluation variants

Threading

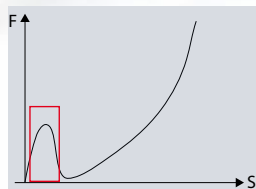

The threading area performs a check to determine whether the maximum force will be exceeded at the start of a joining process. An alarm will notify a warning that parts or the tool could possibly be damaged. The threading area must be activated.

Gates

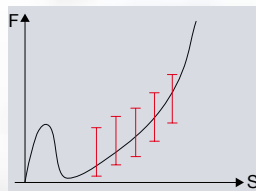

With the auto-configuration, 5 gates will be activated. A gate is defined by a path position and a minimum and maximum force. The forced-displacement curve for good parts must run through all the gates, and no gate may be circumvented. The evaluation is performed when the press stroke has exceeded the path position of all the gates.

Force thresholds

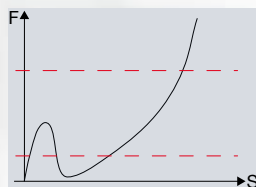

Force thresholds define a minimum force to be achieved and a maximum force threshold, within which the entire force fitting process must be performed once the minimum force has been reached.

Block area End position

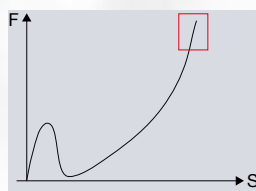

Often the force fitting process is concluded with a high force exertion at the end of the stroke: the block area. It is defined by a force and displacement range which may not be under-run or exceeded. The block area is always inactive after the auto-configuration and must be activated as required.

Press-fit stem path

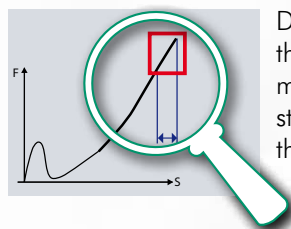

During the deformation processes which occur at the end of the stroke, the press-fit stem path can also be monitored. The press-fit stem path monitoring can only be activated with an active block area. The press-fit stem path is calculated from the path differential between the reaching of the block area and the beginning of the return stroke.

OK/NOK notifications

The ForceMaster confirms the manufacturing of an OK part with a green indicator light. A NOK part is notified with a pre-settable signal tone and a red indicator light. By default, the TPC ForceMaster is pre-set in such a manner that the NOK message can only be acknowledged with a master-card. In the manual configuration of the measurement program, this feature can be disabled.

ForceMaster structural layout

From left to right:

- ▶ Card slot
- ▶ Speaker
- ▶ OK / NOK indicator lights
- ▶ Rotary pushbutton for programming

Counter

Six different counter types can be set via the configuration menu:

- ▶ OK parts
- ▶ NOK parts
- ▶ Total of all parts
- ▶ Count down counter
- ▶ R-set (set value for countdown counter)
- ▶ Total stroke counter



Software

The software for the visualisation and correction of the auto-configuration is included in the scope of delivery.

Options:

USB interface for a USB stick

The graphical curve data can be stored on a USB stick for documentation and evaluation purposes. The cycle time should be ≥ 3 seconds.

Cam PLC

The cam PLC functions in the same manner as an electronic, path-controlled step chain controller. When a cam is reached, the movement direction of the press ram is also evaluated. This enables the programming of an action in the cam area, which is dependent on the work or return stroke. This is based on a step chain control, which sequentially performs an array of processes. Only when a condition is fulfilled will an action be executed and a jump to the next step be performed.

There are 8 inputs and 8 outputs available for programming. The cam PLC can not be used for press-safety purposes.

SmartCards

Tool card
PLC card

Single-dimensional operation

It is also possible to operate the TPC ForceMaster with the force sensor only.

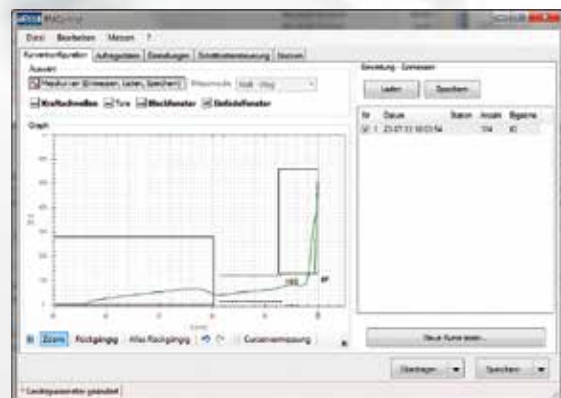

TPC ForceMaster Technical Data

General device data

Display:	2-line backlit LCD display
Warning and acknowledgement sounds:	type of signal can be set up to 100 dB
Warning sound volume:	up to 100 dB
Measuring channels:	force/displacement or force/time
Communication interfaces:	USB - Type B slave port, on the rear side RS232 - D-SUB 9, data rate 19.2 kbps
Interface:	USB, RS232
Measurement error:	0.5% from calibration
Electrical connection:	90 ... 240 V AC / 50 ... 60 Hz
Cut-off frequency:	1 kHz
Working temperature range:	0 ... 60 °C
Humidity:	10 ... 80%, non-condensing
Housing:	aluminium profile housing
Protection class:	IP20
Connections:	coded special connectors
Sampling rate:	10 kHz
Number of I/O:	8 inputs / 8 outputs
Dimensions (W x H x D):	150 x 95 x 260 [mm]
Weight: approx.	3 kg

TPC ForceMaster sensors

Load cell for TPC ForceMaster

The ideal, user-friendly force sensors for hand lever presses.
Cross-thread for the tool attachment.

Overall measurement error:	< ± 1% from calibration
Maximum usage force:	approx. 120% of the rated power
Protection class:	according to EN 60529: IP54
Diameter:	50 mm
Height without clamping pin:	50 mm
Clamping pin diameter:	10 ^{e7} x 21 mm
Sensor bore diameter x depth:	10 ^{H7} x 25 mm

The sensor must not be subjected to lateral forces.

Potentiometer

Linearity deviation:	from 0.1% from calibration
Resolution:	0.01 mm
Protection class according to EN 60529:	IP 40

Retrofit kit for potentiometer

Existing hand lever presses can be retrofitted with a potentiometer with the retrofit kit. An illustration with the drilling pattern is included.



Measurement ranges	Max. overload
0 - 100 N	1 kN
0 - 250 N	2.5 kN
0 - 0.5 kN	5 kN
0 - 1.0 kN	10 kN
0 - 2.5 kN	25 kN
0 - 5.0 kN	30 kN
0 - 10.0 kN	30 kN
0 - 25.0 kN	30 kN

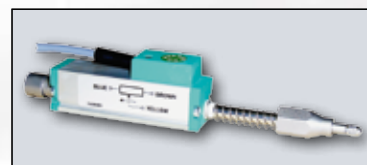

The accessories

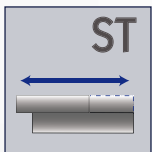
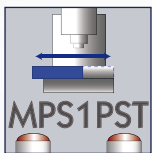
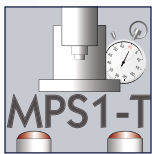
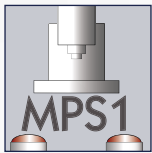
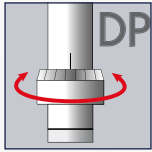

Pneumatic toggle presses APK*L and VKL range

The optimum transmission ratio of the toggle lever produces large forces at the end of the stroke and ensures low air consumption. The resulting low energy consumption means that **mäder** pneumatic toggle presses are a cost-effective production tool, not only at the procurement stage but also in the long term.

All pneumatic toggle presses can be provided with the standard **mäder** MPS-1 controller or with customer-specified controllers.

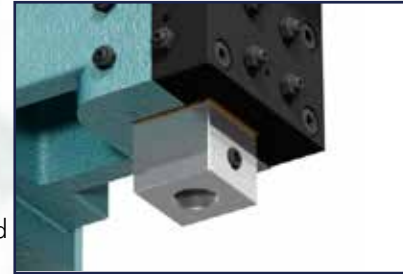

Square Ram

Other quality features:

- ▶ Factory pre-set pressure point
- ▶ Right-angled gearbox for simple height adjustment of the press head
- ▶ Side-mounted measuring strip for fast reproduction of settings when changing the tool
- ▶ Practically maintenance-free double-acting cylinder
- ▶ Low noise: less than 75 dB

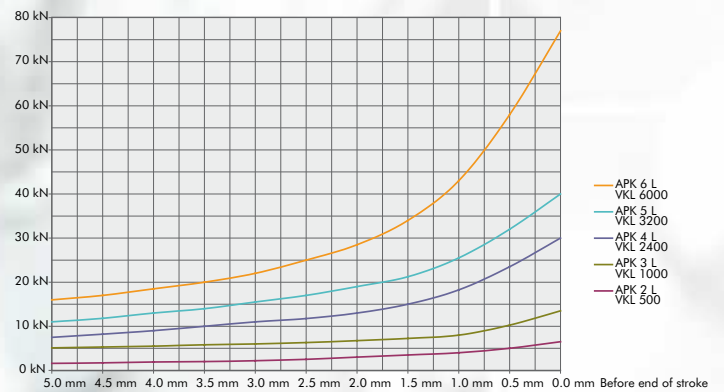

APK 2L VKL 0500-35-80

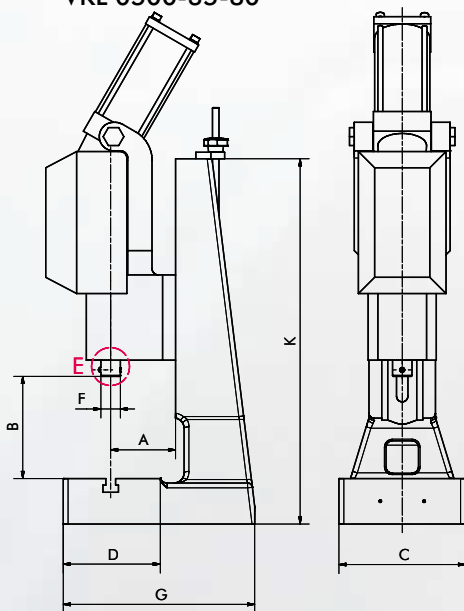

Standard

With DP

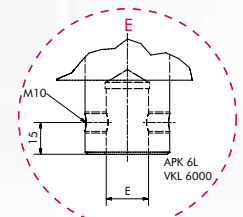
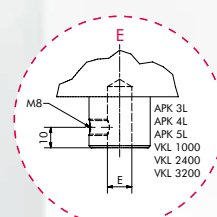
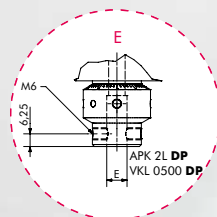
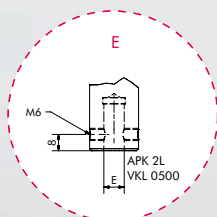
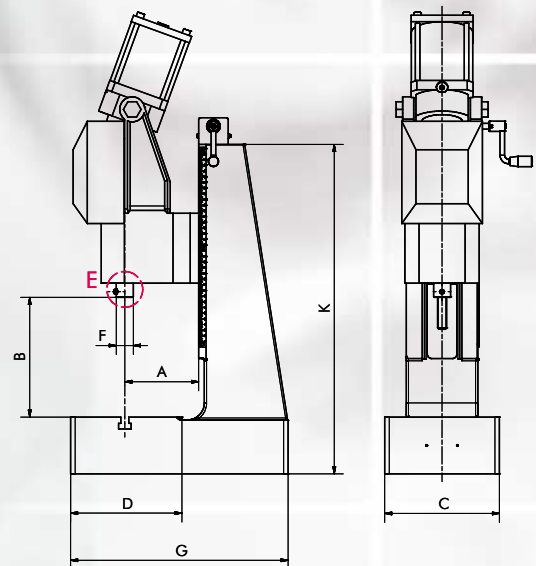

APK Series with round ram
VKL Series with square ram



APK 2 L

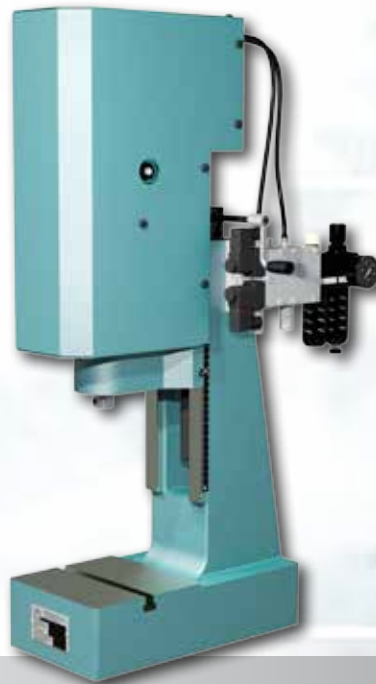

APK 4 L / APK 5 L



VKL 6000-40-150

Type			with round ram				
			APK 2 L	APK 3 L	APK 4 L	APK 5 L	APK 6 L
Capacity at 6 bar		kN	5	10	24	32	60
Working stroke		mm	35	40	40	40	40
Throat	A	mm	80	100	130	130	150
Daylight	B	mm	80 - 265	110 - 280	175 - 330	175 - 330	87 - 310
Daylight with DP	B	mm	65 - 250	-	-	-	-
Table size	CxD	mm	157 - 115	185 - 145	200 x 190	200 x 190	300 x 210
T-slot width similar to DIN 650		mm	10	12	14	14	20
Ram bore Ø x Depth	E	mm	10 ^{H7} x 25	12 ^{H7} x 30	12 ^{H7} x 30	12 ^{H7} x 30	20 ^{H7} x 34
Ram Ø	F	mm	24	30	30	30	40
Air connection			G 1/4"	G 1/4"	G 3/8"	G 3/8"	G 3/8"
Air consumption/cm cyl. stroke		l	0.26	0.41	1.05	1.05	1.65
Space requirement	CxG	mm	157 x 237	185 x 320	200 x 385	200 x 385	300 x 455
Stand height	K	mm	450	520	580	580	630
Weight		kg	ca. 22	ca. 55	ca. 95	ca. 96	ca. 140

Accessories (see Page 5)		Please specify when ordering.				
Precision ram adjustment		DP	DP	-	-	-

Type			VKL 0500-35-80	VKL 1000-40-100	with square ram		VKL 6000-40-150
					VKL 2400-40-130	VKL 3200-40-130	
Capacity at 6 bar		kN	5	10	24	32	60
Working stroke		mm	35	40	40	40	40
Throat	A	mm	80	100	130	130	150
Daylight	B	mm	80 - 265	110 - 280	175 - 330	175 - 330	90 - 320
Daylight with DP	B	mm	65 - 250	-	-	-	-
Table size	CxD	mm	157 x 115	185 x 145	200 x 190	200 x 190	300 x 210
T-slot width similar to DIN 650		mm	10	12	14	14	20
Ram bore Ø x Depth	E	mm	10 ^{H7} x 25	12 ^{H7} x 30	12 ^{H7} x 30	12 ^{H7} x 30	20 ^{H7} x 34
Ram Ø	F	mm	25 x 25	31 x 31	31 x 31	31 x 31	41 x 41
Air connection			G 1/4"	G 1/4"	G 3/8"	G 3/8"	G 3/8"
Air consumption/cm cyl. stroke		l	0.26	0.41	1.05	1.05	1.65
Space requirement	CxG	mm	157 x 237	185 x 320	200 x 385	200 x 385	300 x 455
Stand height	K	mm	450	520	580	580	630
Weight		kg	ca. 22	ca. 55	ca. 95	ca. 96	ca. 140

Accessories (see Page 5)		Please specify when ordering.				
Precision ram adjustment		DP	DP	-	-	-

Valve and service unit only included with controller. Design may vary.

The accessories

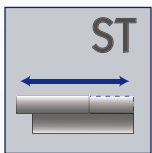
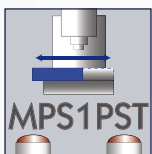
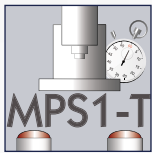
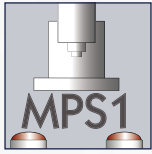

Pneumatic toggle presses XL-APK*L and XL-VKL range

Presses with XL throat are designed for processing large and bulky parts. The press stand consists of a stable welded structure which can be modified to suit customers' requirements. XL pneumatic toggle presses can be provided with the standard **mäder** MPS-1 controller or with customer-specified controllers.

Other quality features:

- ▶ Factory pre-set pressure point
- ▶ Right-angled gearbox for simple height adjustment of the press head
- ▶ Side-mounted measuring strip for fast reproduction of settings when changing the tool
- ▶ Practically maintenance-free double-acting cylinder
- ▶ Low noise: less than 75 dB

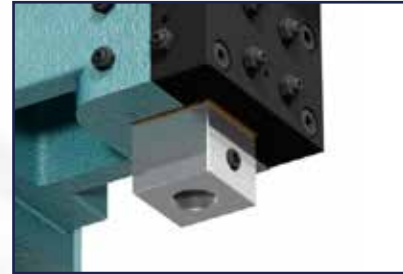

Square ram

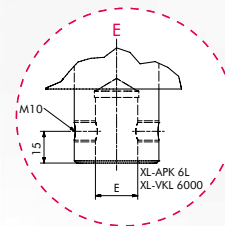
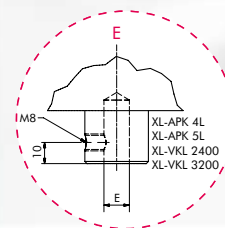
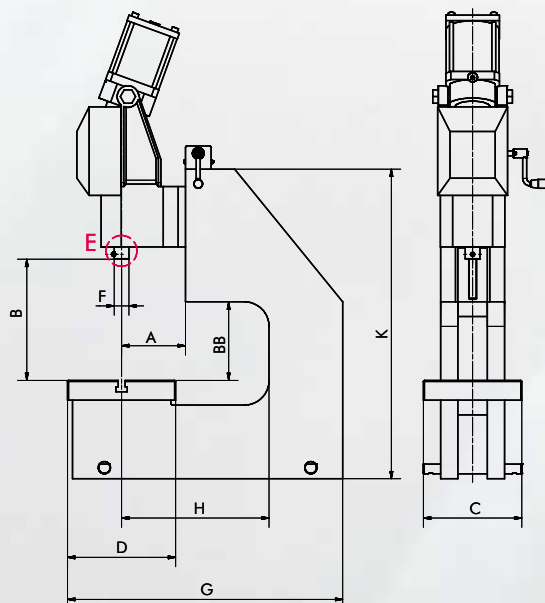
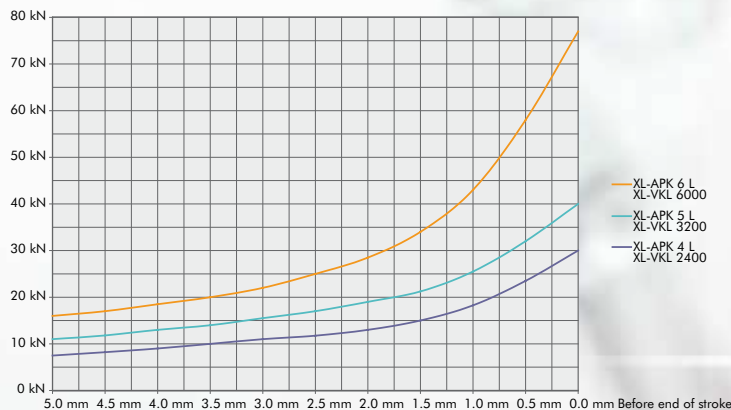

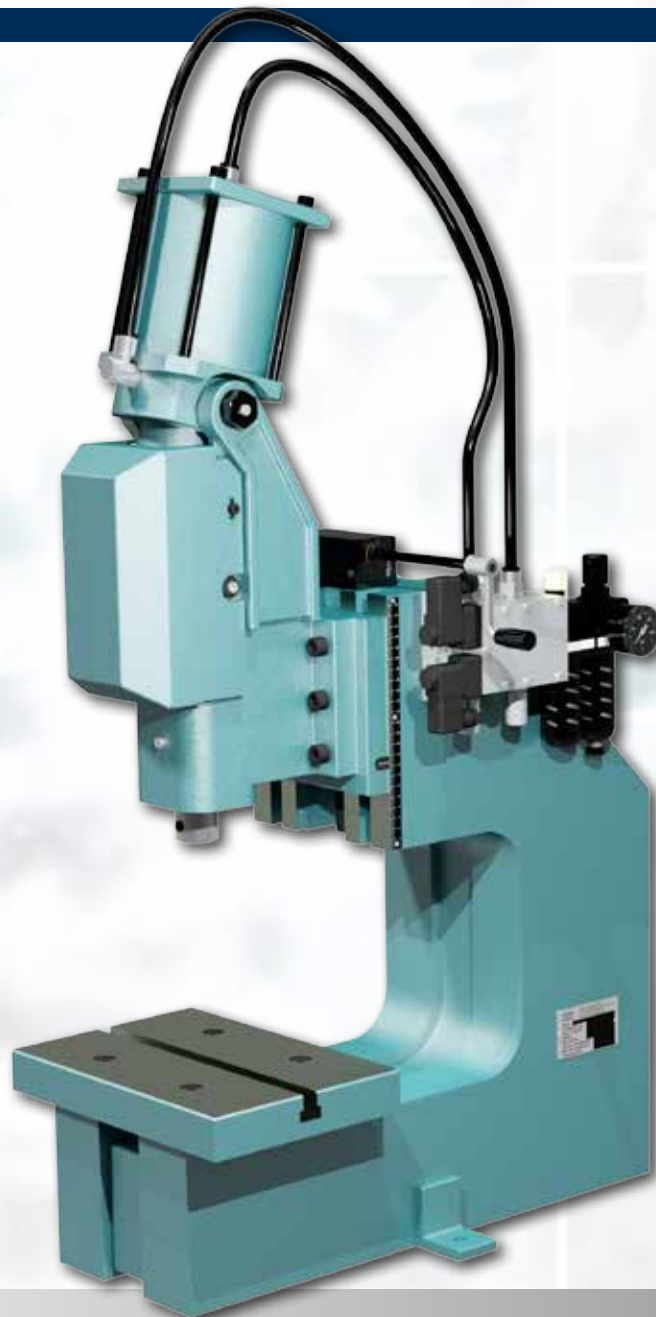

XL-APK 6 L

Type	with round ram					with square ram		
			XL-APK 4 L	XL-APK 5 L	XL-APK 6 L	XL-VKL 2400-40-300	XL-VKL 3200-40-300	XL-VKL 6000-40-300
Capacity at 6 bar		kN	24	32	60	24	32	60
Working stroke		mm	40	40	40	40	40	40
Throat	A	mm	130	130	150	130	130	150
Throat C-frame	H	mm	300	300	300	300	300	300
Daylight	B	mm	130 - 280	130 - 280	130 - 230	130 - 280	130 - 280	130 - 230
Daylight C-frame	BB	mm	158	158	190	158	158	190
Table size	CxD	mm	200 x 220	200 x 220	310 x 220	200 x 220	200 x 220	310 x 220
T-slot width similar to DIN 650		mm	14	14	16	14	14	16
Ram bore Ø x Depth	E	mm	12 ^{H7} x 30	12 ^{H7} x 30	20 ^{H7} x 34	12 ^{H7} x 30	12 ^{H7} x 30	20 ^{H7} x 34
Ram Ø / Ram area	F	mm	30	30	40	31 x 31	31 x 31	41 x 41
Air connection			G 3/8"	G 3/8"	G 3/8"	G 3/8"	G 3/8"	G 3/8"
Air consumption/cm cyl. stroke		l	1.05	1.05	1.65	1.05	1.05	1.65
Space requirement	CxG	mm	200 x 560	200 x 560	320 x 610	200 x 560	200 x 560	320 x 610
Stand height	K	mm	630	630	630	630	630	630
Weight		kg	ca. 149	ca. 150	ca. 250	ca. 149	ca. 150	ca. 250

Valve and service unit only included with controller. Design may vary.

The accessories

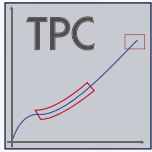

Manually assisted pneumatic toggle presses

Manually assisted toggle presses are used when, due to particular features of the workpiece, both hands cannot be engaged in two-handed operation at the beginning of the working stroke and a large force still has to be achieved at the end of the stroke.

With the NP manually assisted pneumatic toggle presses, safe working is possible in such cases. The ram is lowered to the power stroke position using the manual lever and the workpiece is then held by the force of the lever. A sensor registers this position. At the same time, the workpiece can be released and a pushbutton pressed with the second hand which then initiates the power stroke.

The power stroke can only be initiated when both hands are engaged. Hence, if the manual lever were released, for example, the ram would be raised by a safety mechanism and the permission for the power stroke in the controller would thus be removed.

The length of the pneumatic power stroke of NP manually assisted pneumatic toggle presses and therefore the TDC position can be steplessly adjusted with high precision from 0 mm - 6 mm stroke length using the standard fine adjustment facility.

As a result of the special transmission mechanism, a constant power stroke is available over the whole length of the stroke.

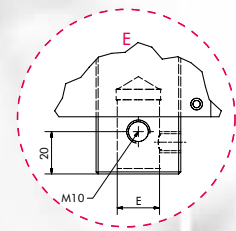
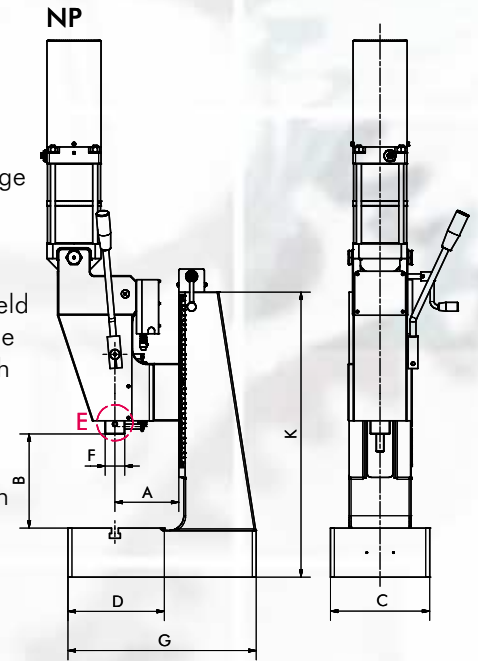

Complete unit



Stroke adjustment

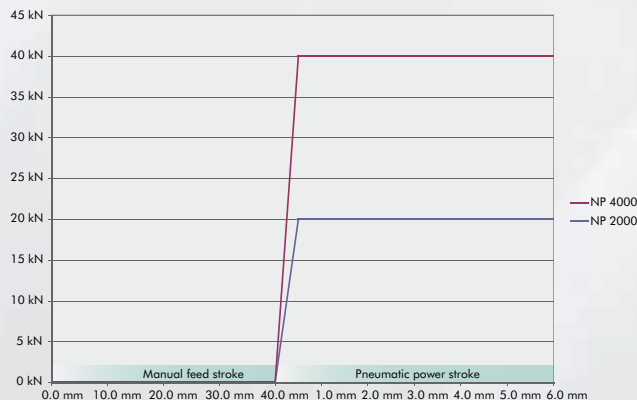

XL-NP

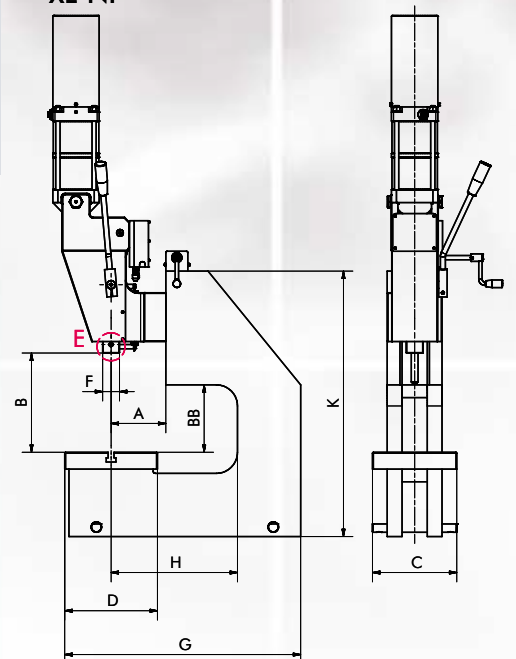



NP 2000

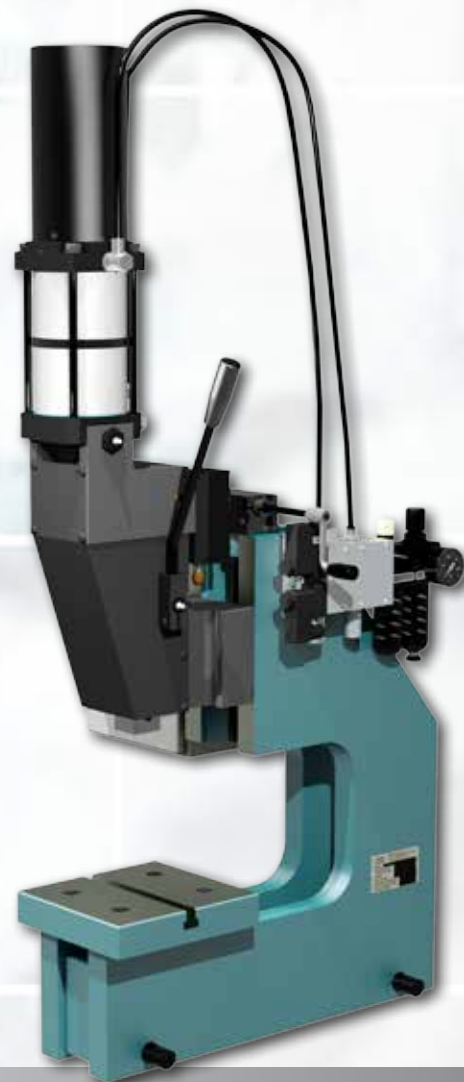

XL-NP 4000

Type			NP 2000	NP 4000	XL-NP 2000	XL-NP 4000
Capacity at 6 bar		kN	20	40	20	40
Manual feed stroke		mm	40	40	40	40
Pneumatic power stroke		mm	0 - 6	0 - 6	0 - 6	0 - 6
Throat	A	mm	130	130	130	130
Throat C-frame	H	mm	-	-	300	300
Daylight	B	mm	58 - 325	58 - 325	125 - 265	125 - 265
Daylight C-frame	BB	mm	-	-	158	158
Table size	CxD	mm	200 x 190	200 x 190	200 x 220	200 x 220
T-slot width similar to DIN 650		mm	14	14	14	14
Ram bore Ø x Depth	E	mm	20 ^{H7} x 25	20 ^{H7} x 25	20 ^{H7} x 25	20 ^{H7} x 25
Ram Ø	F	mm	40 x 40	40 x 40	40 x 40	40 x 40
Air connection			G 3/8"	G 3/8"	G 3/8"	G 3/8"
Air consumption/cm cyl. stroke		l	0.5	0.75	0.5	0.75
Space requirement	CxG	mm	200 x 385	200 x 385	200 x 560	200 x 560
Stand height	K	mm	580	580	630	630
Weight		kg	ca. 95	ca. 96	ca. 135	ca. 136

Manually assisted pneumatic toggle presses

DA range

DA presses are the logical implementation of modern press technology for direct-acting pneumatic presses. Due to their modular design, exactly the size needed for the application can be selected, thus optimising the price/performance ratio.

Standard stroke lengths from 40 mm to 120 mm are available in 20 mm steps. Special lengths can be provided on request.

Direct-acting pneumatic presses produce a constant force over the whole stroke length. All direct-acting pneumatic presses can be provided as automation components or with **mäder** controllers for individual workstations.

The processing of sheet metal, printed circuit boards and other bulky components requires presses to have a larger throat. XL-DA presses with 250 mm and 300 mm throat enable even these workpieces to be processed. L-DA presses with up to 350 mm daylight are used for tall parts which require more vertical space. For dimensions which lie outside the standard, presses with press frames in welded design can be manufactured to your specifications.

DA presses are practically maintenance-free, as all moving parts are mounted in bearings. Cylinders are pre-greased and are therefore suitable for oil-free operation.

Quality features:

- ▶ Anti-twist, hard-chrome-plated ram guided in Teflon bushes
- ▶ Simple adjustment of the height of the press head using a threaded spindle and right-angle gearbox
- ▶ Side-mounted measuring strip for fast reproduction of settings when changing the tool
- ▶ Practically maintenance-free double-acting cylinder
- ▶ Adjustable cylinder end-position damping
- ▶ Low noise: less than 75 dB





Sensors are not included

Adjusting the stroke of DA presses

DA presses are fitted as standard with an innovative, precise and easy-to-use system which enables accurate stroke adjustment and protects the ram against twisting.

Operation:

- ▶ The press depth can be adjusted to a reading accuracy of 0.01 mm over the whole stroke length with only one scale nut (A). The stroke length can be read off using the side scale (B) and the vernier on the scale nut (A).
- ▶ The position of the ram can be checked by means of reed contacts (C) which are slid onto the standard scale.
- ▶ The sensors do not have to be readjusted when the stroke length is changed, as the stroke length control magnets always move to the same end positions.

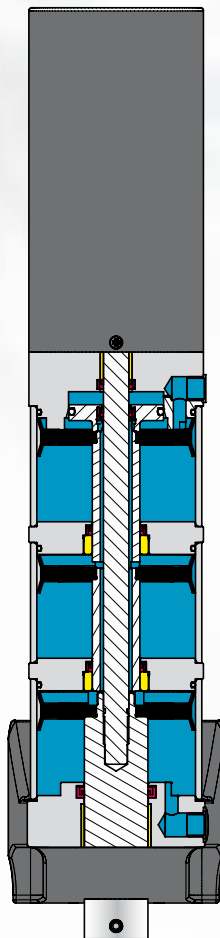

Tandem cylinders

The energy-efficient tandem cylinder design is used for larger forces. Several pneumatic cylinders are connected in tandem, thus increasing the force of the cylinder accordingly. The air consumption is optimised, as the return stroke is only via one cylinder chamber. The press can be operated using only two air connections, as the air is channelled within the pneumatic cylinder.

The accessories

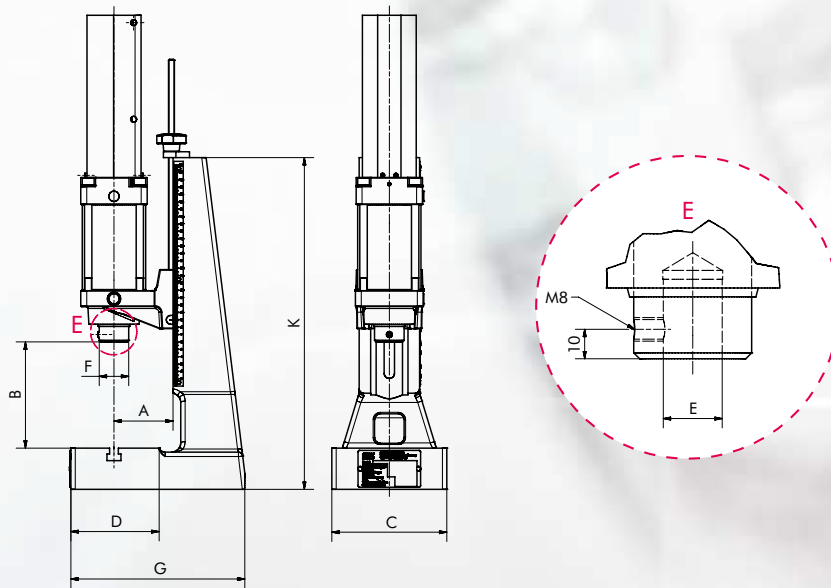
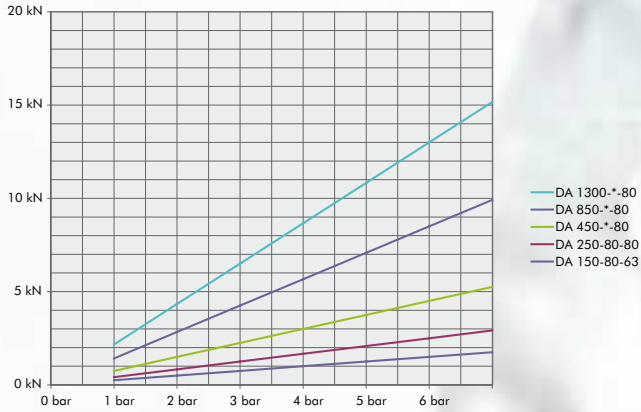
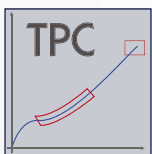
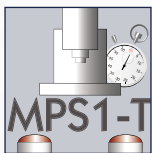
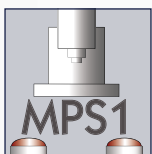
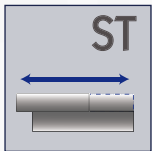
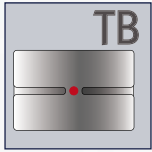

For details of fine stroke adjustment see page 31

DA Series with round ram
L-DA Series with round ram, daylight 350 mm

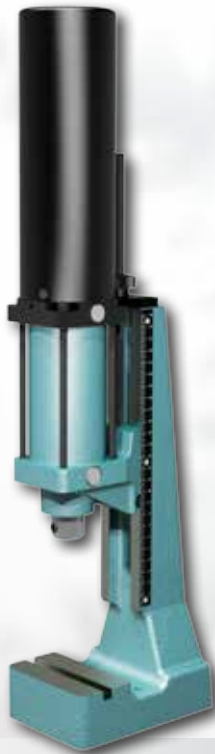

DA 150-80-63

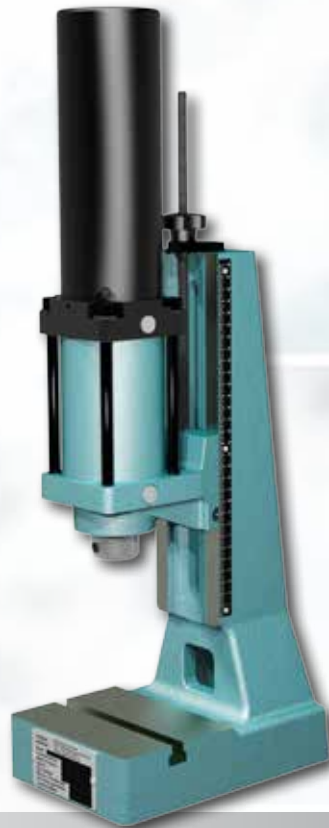

DA 250-80-80

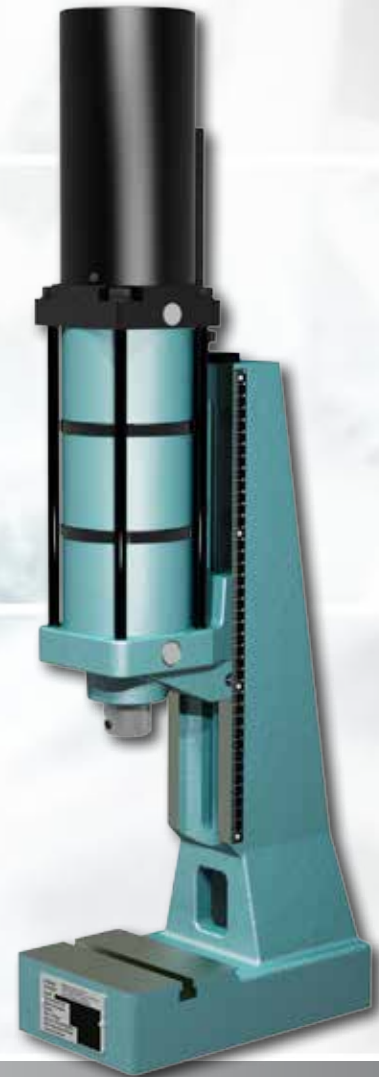

L-DA 1300-40-80

Type			DA 150-80-63	DA 250-80-80	L-DA 250-80-80	DA 450-* -80	L-DA 450-* -80	DA 850-* -80	L-DA 850-* -80	L-DA 1300-* -80
Capacity at 6 bar		kN	1.5	2.5	2.5	4.5	4.5	8.5	8.5	13
Working stroke max.*		mm	80	80	80	40/60/80/ 100/120	40/60/80/ 100/120	40/60/80/ 100/120	40/60/80/ 100/120	40/60/80/ 100/120
Throat	A	mm	63	80	80	80	80	80	80	80
Daylight	B	mm	40 - 215	70 - 280	65 - 390	58 - 243	65 - 350	58 - 243	65 - 350	65 - 350
Table size	CxD	mm	100 x 65	157 x 115	157 x 115	157 x 115	157 x 115	157 x 115	157 x 115	157 x 115
T-slot width similar to DIN 650		mm	10	12	12	12	12	12	12	12
Ram bore Ø x Depth	E	mm	16 ^{H7} x 25	20 ^{H7} x 25	20 ^{H7} x 25	20 ^{H7} x 25	20 ^{H7} x 25	20 ^{H7} x 25	20 ^{H7} x 25	20 ^{H7} x 25
Ram Ø	F	mm	30	40	40	40	40	40	40	40
Air connection			G 1/4"	G 1/4"	G 1/4"	G 3/8"	G 3/8"	G 3/8"	G 3/8"	G 3/8"
Air consumption/cm cyl. stroke		l	0.2	0.3	0.3	1.0	1.0	1.5	1.5	2.1
Space requirement	CxG	mm	110 x 164	157 x 237	155 x 280	155 x 237	156 x 275	155 x 237	156 x 275	156 x 275
Stand height	K	mm	355	450	570	450	570	450	570	570
Weight		kg	ca. 11.5	ca. 25	ca. 31	ca. 28	ca. 34	ca. 31	ca. 37	ca. 40

Extras (siehe Seite 5)

Please specify when ordering.

Table bore 12 ^{H7}	TB	TB	TB	TB	TB	TB	TB	TB	TB
-----------------------------	----	----	----	----	----	----	----	----	----

* Specify the stroke length when ordering.

Valve and service unit only included with controller. Design may vary.

Direct-acting pneumatic presses

The accessories

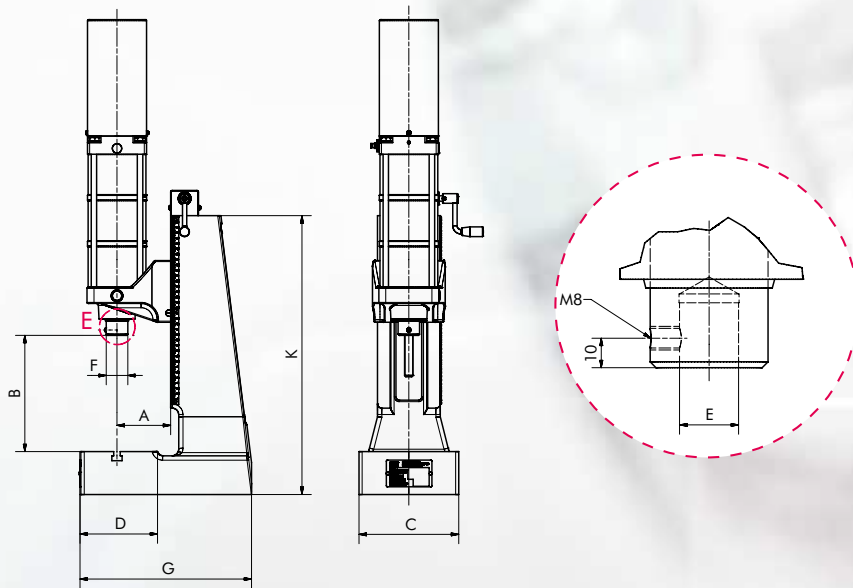
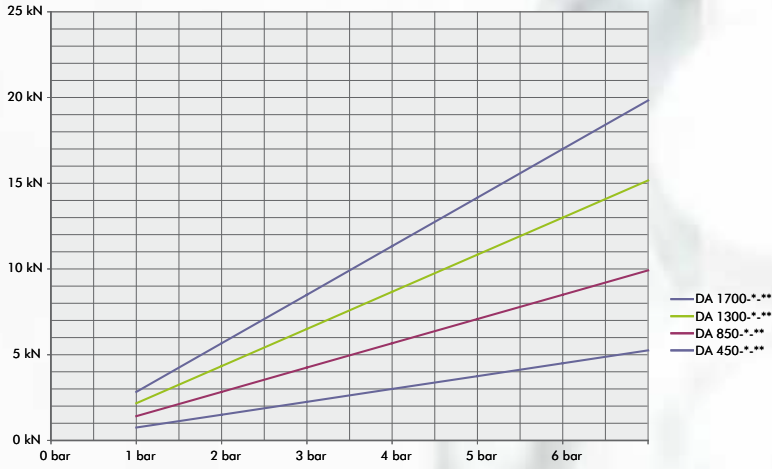
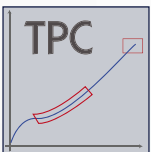
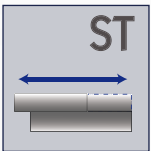
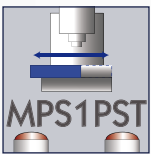
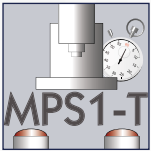
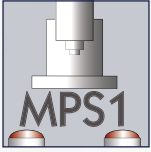

For details of fine stroke adjustment see page 31



DA 850-40-100

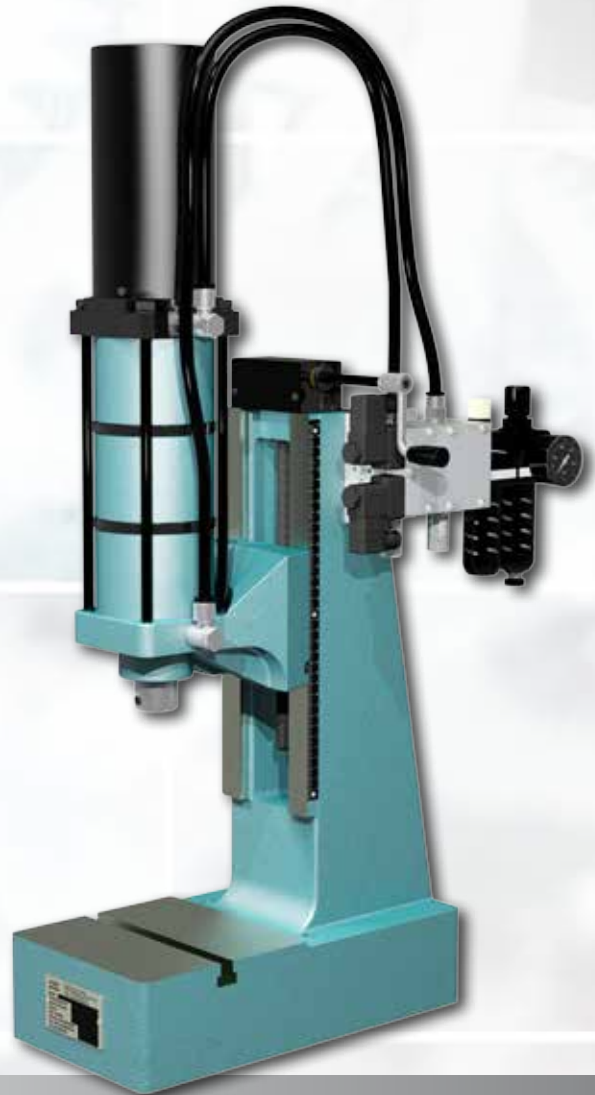

DA 1300-40-130

Direct-acting pneumatic presses

Type		DA 450-*.100	DA 850-*.100	DA 1300-*.100	DA 1700-*.100
Capacity at 6 bar	kN	4.5	8.5	13.0	17.0
Working stroke max.*	mm	40/60/80/100/120	40/60/80/100/120	40/60/80/100/120	40/60/80/100/120
Throat	A mm	100	100	100	100
Daylight	B mm	60 - 285	60 - 285	60 - 285	60 - 285
Table size	CxD mm	185 x 145	185 x 145	185 x 145	185 x 145
T-slot width similar to DIN 650	mm	12	12	12	12
Ram bore Ø x Depth	E mm	20 ^{H7} x 25	20 ^{H7} x 25	20 ^{H7} x 25	20 ^{H7} x 25
Ram Ø	F mm	40	40	40	40
Air connection		G 3/8"	G 3/8"	G 3/8"	G 3/8"
Air consumption/cm Cyl. stroke	l	1.0	1.5	2.1	2.6
Space requirement	CxG mm	185 x 320	185 x 320	185 x 320	185 x 320
Stand height	K mm	520	520	520	520
Weight	kg	ca. 62	ca. 65	ca. 68	ca. 71

DA 450-*.130	DA 850-*.130	DA 1300-*.130	DA 1700-*.130
4.5	8.5	13.0	17.0
40/60/80/100/120	40/60/80/100/120	40/60/80/100/120	40/60/80/100/120
130	130	130	130
70 - 325	70 - 325	70 - 325	70 - 325
200 x 190	200 x 190	200 x 190	200 x 190
14	14	14	14
20 ^{H7} x 25	20 ^{H7} x 25	20 ^{H7} x 25	20 ^{H7} x 25
40	40	40	40
G 3/8"	G 3/8"	G 3/8"	G 3/8"
1.0	1.5	2.1	2.6
200 x 385	200 x 385	200 x 385	200 x 385
580	580	580	580
ca. 77	ca. 80	ca. 83	ca. 86

* Specify the stroke length when ordering.

Valve and service unit only included with controller. Design may vary.

The accessories

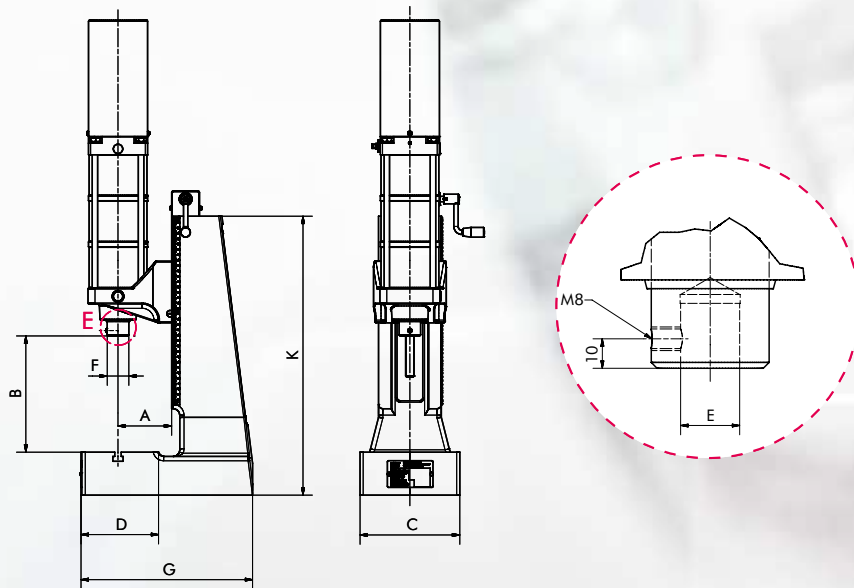
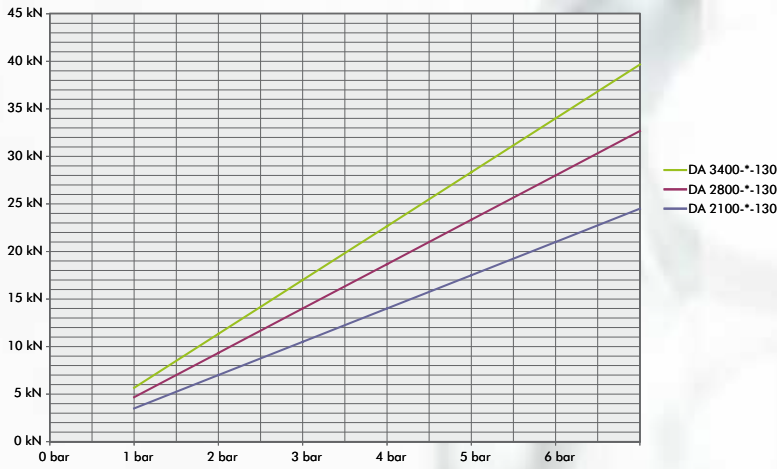
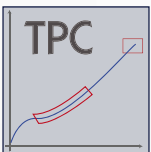
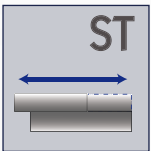
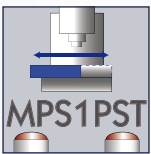
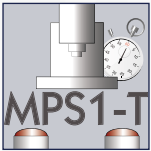
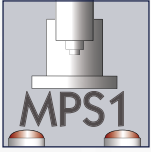

For details of fine stroke adjustment see page 31



DA 3400-40-130

Type			DA 2100-*.130	DA 2800-*.130	DA 3400-*.130
Capacity at 6 bar		kN	21.0	28.0	34.0
Working stroke max.*		mm	40/60/80/100/120	40/60/80/100/120	40/60/80/100/120
Throat	A	mm	130	130	130
Daylight	B	mm	75 - 330	75 - 330	75 - 330
Table size	CxD	mm	200 x 190	200 x 190	200 x 190
T-slot width similar to DIN 650		mm	14	14	14
Ram bore Ø x Depth	E	mm	20 ^{H7} x 25	20 ^{H7} x 25	20 ^{H7} x 25
Ram Ø	F	mm	40	40	40
Air connection			G 3/8"	G 3/8"	G 3/8"
Air consumption/cm cyl. stroke		l	3.0	3.7	4.5
Space requirement	CxG	mm	200 x 385	200 x 385	200 x 385
Stand height	K	mm	580	580	580
Weight		kg	ca. 92	ca. 99	ca. 105

* Specify the stroke length when ordering.

Valve and service unit only included with controller. Design may vary.

Direct-acting pneumatic presses

The accessories

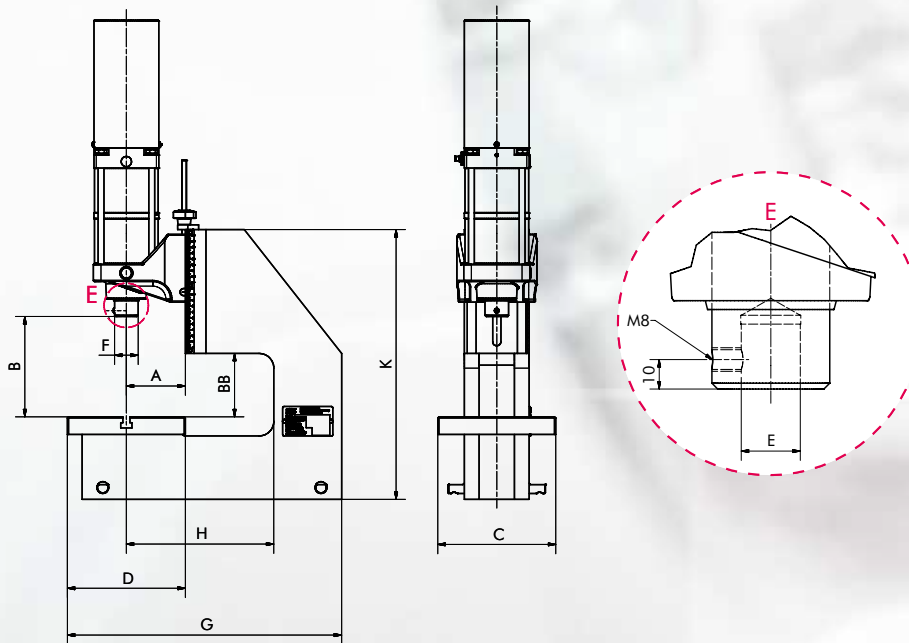
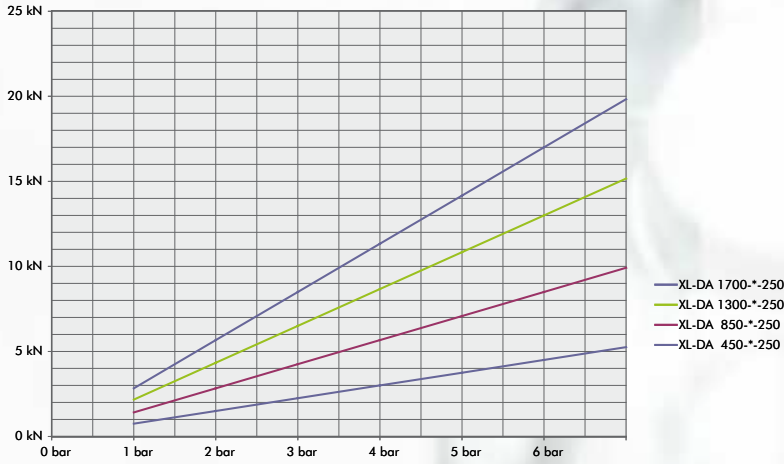
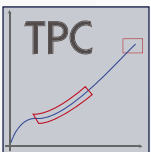
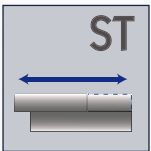
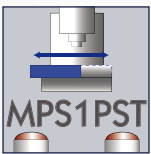
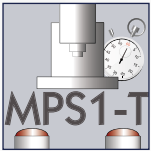
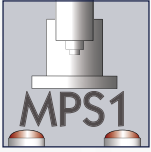

For details of fine stroke adjustment see page 31

XL- Direct-acting pneumatic presses

DA-Serie with round ram, with 250 mm throat



XL-DA 1300-40-250

Type			XL-DA 450-*-250	XL-DA 850-*-250	XL-DA 1300-*-250	XL-DA 1700-*-250
Capacity at 6 bar		kN	4.5	8.5	13.0	17.0
Working stroke max.*		mm	40/60/80/100/120	40/60/80/100/120	40/60/80/100/120	40/60/80/100/120
Throat	A	mm	100	100	100	100
Throat C-frame	H	mm	250	250	250	250
Daylight	B	mm	75 - 175	75 - 175	75 - 175	75 - 175
Daylight C-frame	BB	mm	100	100	100	100
Table size	CxD	mm	200 x 200	200 x 200	200 x 200	200 x 200
T-slot width similar to DIN 650		mm	12	12	12	12
Ram bore Ø x Depth	E	mm	20 ^{H7} x 25	20 ^{H7} x 25	20 ^{H7} x 25	20 ^{H7} x 25
Ram Ø	F	mm	40	40	40	40
Air connection			G 3/8"	G 3/8"	G 3/8"	G 3/8"
Air consumption/cm cyl. stroke		l	1.0	1.5	2.1	2.6
Space requirement	CxG	mm	200 x 465	200 x 465	200 x 465	200 x 465
Stand height	K	mm	465	465	465	465
Weight		kg	ca. 57	ca. 60	ca. 63	ca. 66

* Specify the stroke length when ordering.

Valve and service unit only included with controller. Design may vary.

The accessories

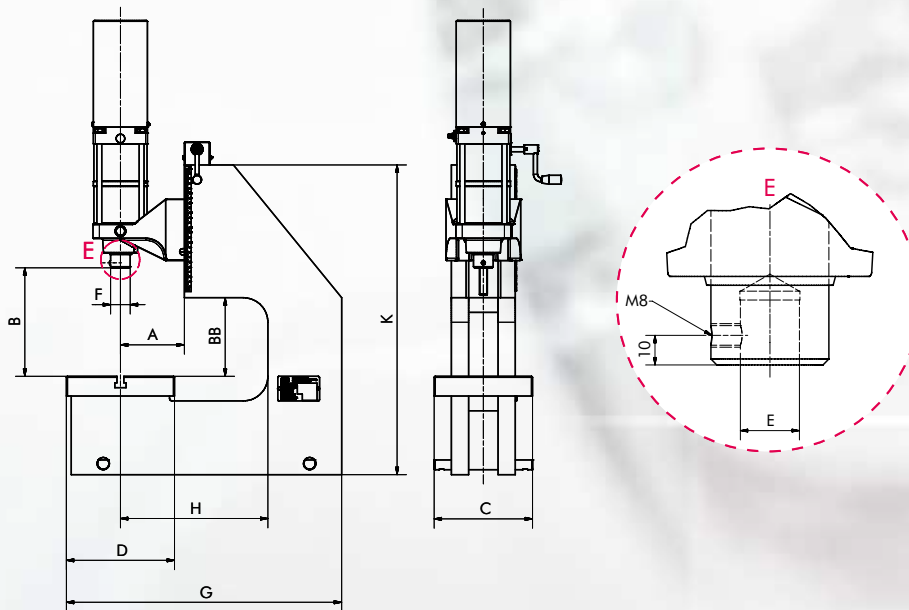
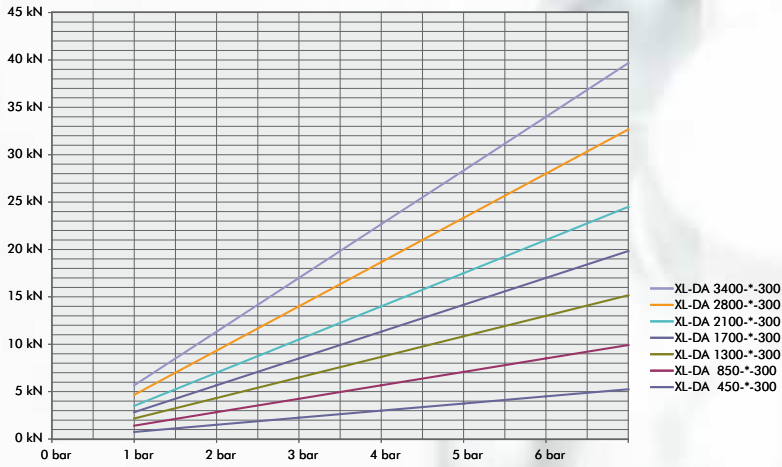
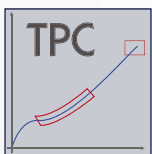
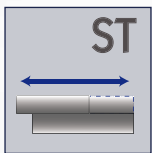
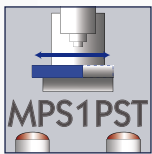
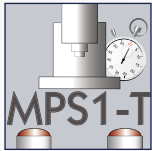
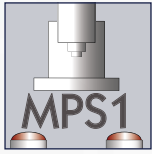

For details of fine stroke adjustment see page 31

XL- Direct-acting pneumatic presses

DA-Series with round ram, with 300 mm throat



XL-DA 2800-40-300

Type			XL-DA 450*-300	XL-DA 850*-300	XL-DA 1300*-300	XL-DA 1700*-300	XL-DA 2100*-300	XL-DA 2800*-300	XL-DA 3400*-300
Capacity at 6 bar		kN	4.5	8.5	13.0	17.0	21.0	28.0	34.0
Working stroke max.*		mm	40/60/80/100/120	40/60/80/100/120	40/60/80/100/120	40/60/80/100/120	40/60/80/100/120	40/60/80/100/120	40/60/80/100/120
Throat	A	mm	130	130	130	130	130	130	130
Throat C-frame	H	mm	300	300	300	300	300	300	300
Daylight	B	mm	140 - 275	140 - 275	140 - 275	140 - 275	130 - 275	130 - 275	130 - 275
Daylight C-frame	BB	mm	158	158	158	158	158	158	158
Table size	CxD	mm	200 x 220	200 x 220	200 x 220	200 x 220	200 x 220	200 x 220	200 x 220
T-slot width similar to DIN 650		mm	14	14	14	14	14	14	14
Ram bore Ø x Depth	E	mm	20 ^{H7} x 25	20 ^{H7} x 25	20 ^{H7} x 25	20 ^{H7} x 25	20 ^{H7} x 25	20 ^{H7} x 25	20 ^{H7} x 25
Ram Ø	F	mm	40	40	40	40	40	40	40
Air connection			G 3/8"	G 3/8"	G 3/8"	G 3/8"	G 3/8"	G 3/8"	G 3/8"
Air consumption/cm Cyl. stroke		l	1.0	1.5	2.1	2.6	3.0	3.7	4.5
Space requirement	CxG	mm	200 x 560	200 x 560	200 x 560	200 x 560	200 x 560	200 x 560	200 x 560
Stand height	K	mm	630	630	630	630	630	630	630
Weight		kg	ca. 135	ca. 138	ca. 141	ca. 144	ca. 141	ca. 158	ca. 164

* Specify the stroke length when ordering.

Valve and service unit only included with controller. Design may vary.

The accessories*

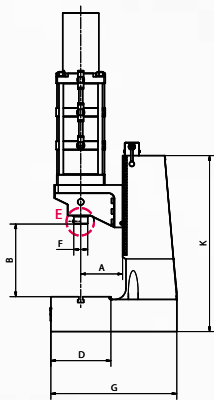
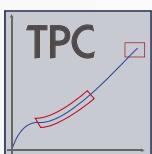
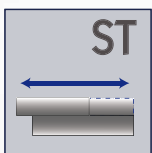
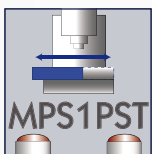
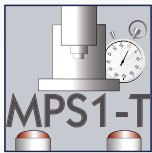
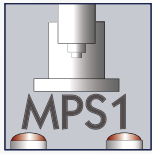

DA Type

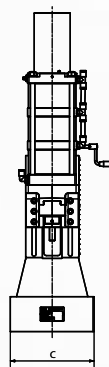

XL-DA Type

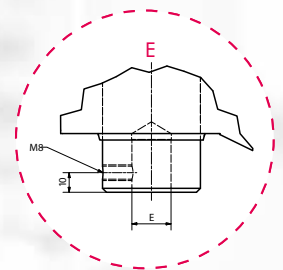
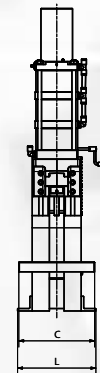
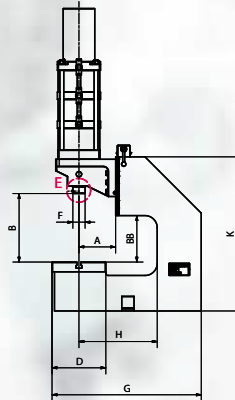

For details of fine stroke adjustment see page 31

DA Series with round ram and 150 mm throat
 XL-DA Series with round ram and 300 mm throat

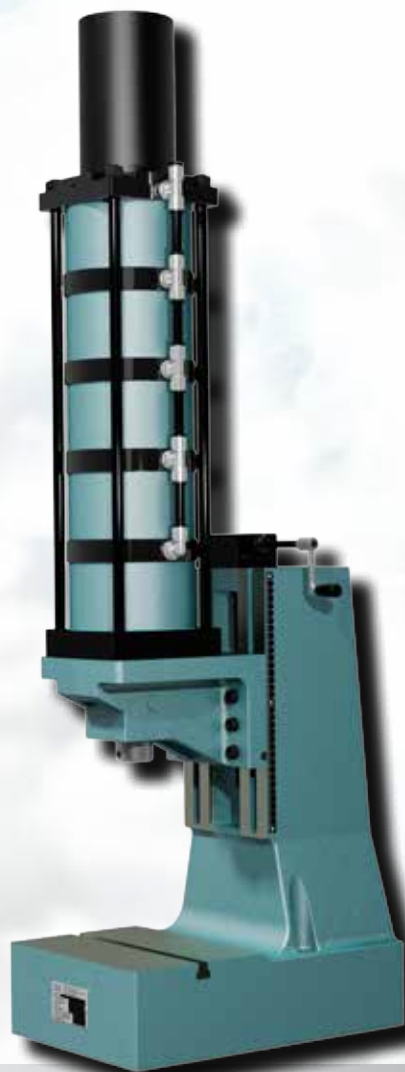

DA 5600-40-150

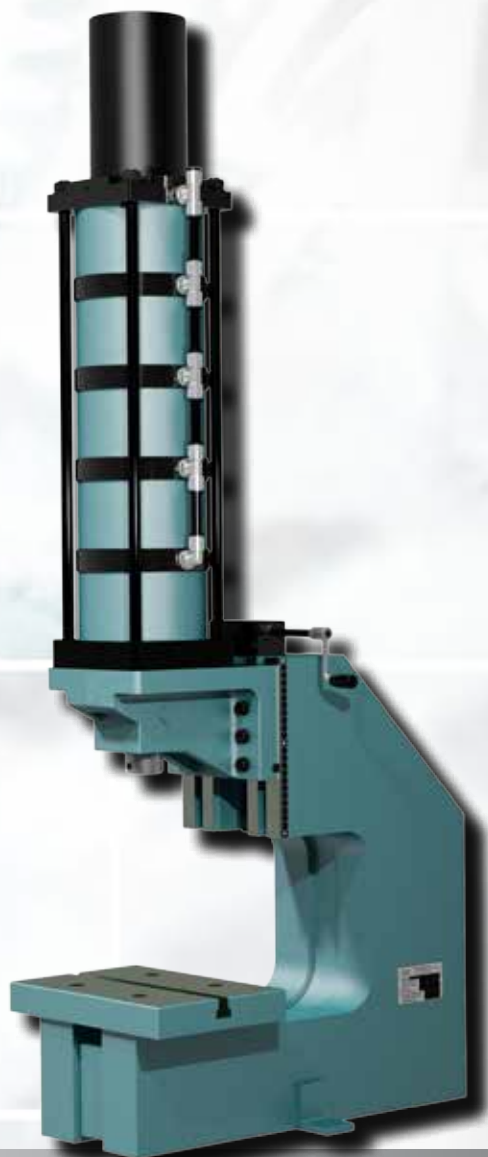

XL-DA 5600-40-300

Type		DA 3300*-150	DA 4500*-150	DA 5600*-150	XL-DA 3300*-300	XL-DA 4500*-300	XL-DA 5600*-300
Capacity at 6 bar	kN	33	45	56	33	45	56
Working stroke max.*	mm	40/60/80/100/120	40/60/80/100/120	40/60/80/100/120	40/60/80/100/120	40/60/80/100/120	40/60/80/100/120
Throat	A mm	150	150	150	150	150	150
Throat C-frame	H mm				300	300	300
Daylight	B mm	155 - 365	155 - 365	155 - 365	195 - 290	195 - 290	195 - 290
Daylight C-frame	BB mm				190	190	190
Table size	CxD mm	300 x 210	300 x 210	300 x 210	310 x 220	310 x 220	310 x 220
T-slot width similar to DIN 650	mm	14	14	14	16	16	16
Ram bore Ø x Depth	E mm	20 ^{H7} x 25	20 ^{H7} x 25	20 ^{H7} x 25	20 ^{H7} x 25	20 ^{H7} x 25	20 ^{H7} x 25
Ram Ø	F mm	50	50	50	50	50	50
Air connection		G 1/2"	G 1/2"	G 1/2"	G 1/2"	G 1/2"	G 1/2"
Air consumption/cm cyl. stroke	l	5.2	6.5	7.9	5.2	6.5	7.9
Space requirement	CxG mm	300 x 455	300 x 455	300 x 455	320 x 610	320 x 610	320 x 610
Stand height	K mm	630	630	630	630	630	630
Weight	kg	227	233	239	300	306	312

* Specify the stroke length when ordering.

Valve and service unit only included with controller. Design may vary.

The accessories

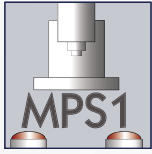

The DAP Portal Press is made up of standard **mäder** components: the DAF press cylinder and the portal frame with ram plate. The cylinder used generates force constantly over the entire stroke length.

mäder DAP Portal Presses are available both as automation components or with **mäder** controllers of type MPS-1 and the TPC-MIDI process monitor.

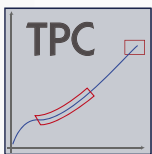
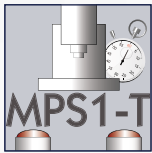

Quality features

- ▶ Large force range from 4.5 kN to 34 kN
- ▶ Stable construction
- ▶ Anti-twist locked and guided ram plate with two columns
- ▶ Ram plate enables flat pressure
- ▶ Cross-shaped slots for secure accommodation of tools
- ▶ Large die space
- ▶ Daylight can be fully occupied by using spacers
- ▶ On request, the Portal Press can also be supplied with other dimensions

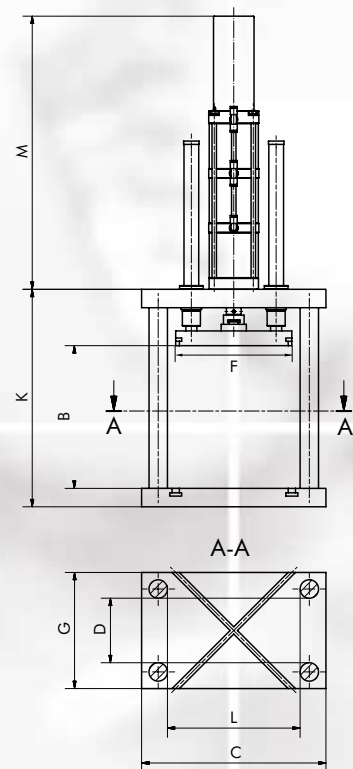
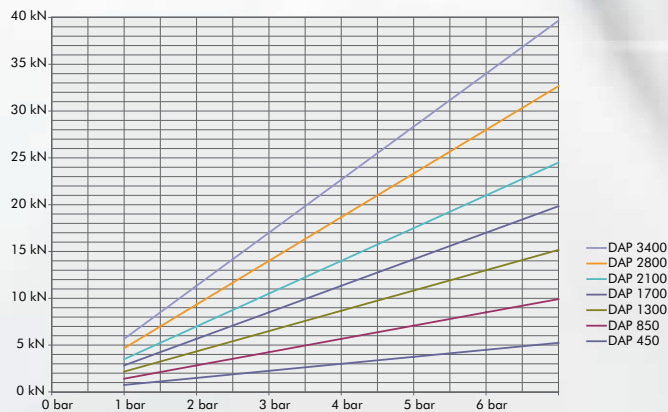

For details of fine stroke adjustment see page 31

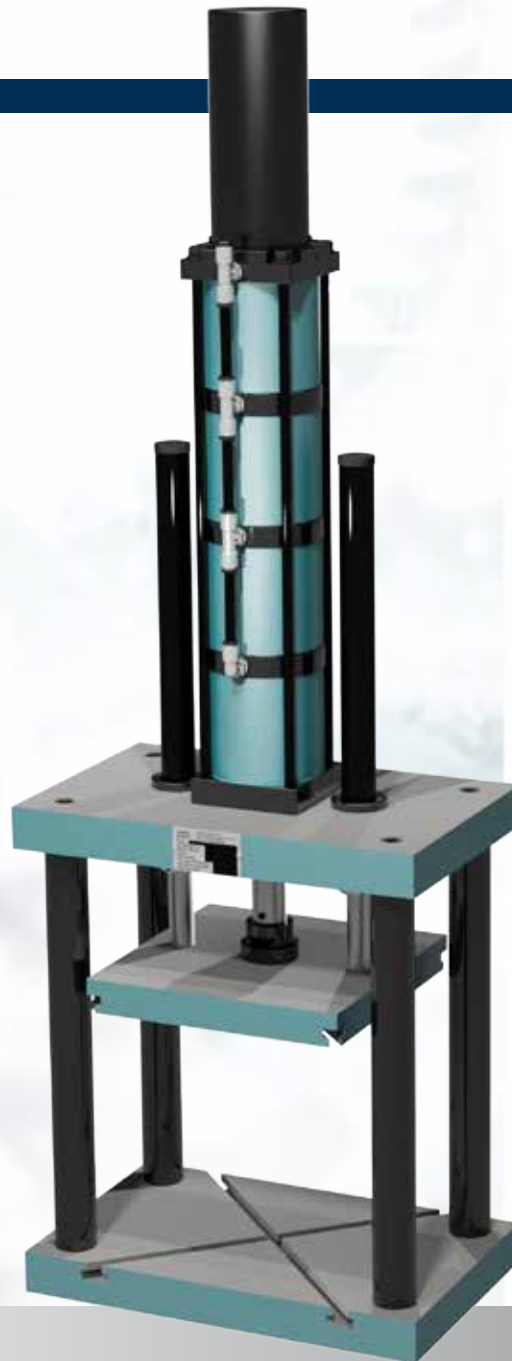

Type			DAP 450-80	DAP 850-80	DAP 1300-80	DAP 1700-80	DAP 2100-80	DAP 2800-80	DAP 3400-80
Capacity		kN	4.5	8.5	13	17	21	28	34
Return force		kN	4	4	4	4	20	27	33
Working stroke		mm	80	80	80	80	80	80	80
Ram plate area	F	mm	315 x 315	315 x 315	315 x 315	315 x 315	315 x 315	315 x 315	315 x 315
Maximum daylight	B	mm	387	387	387	387	387	387	387
Working surface	L x D	mm	360 x 175	360 x 175	360 x 175	360 x 175	360 x 175	360 x 175	360 x 175
Slot width similar to DIN 650		mm	14	14	14	14	14	14	14
Air connection			G3/8"	G3/8"	G3/8"	G3/8"	G3/8"	G3/8"	G3/8"
Air consumption per 10 mm stroke		l	1.0	1.5	2.1	2.6	3.0	3.7	4.5
Space required	C x G	mm	500 x 315	500 x 315	500 x 315	500 x 315	500 x 315	500 x 315	500 x 315
Frame height	K	mm	590	590	590	590	590	590	590
Cylinder height	M	mm	443	569	695	821	741	889	1037
Weight		kg	197	200	203	206	212	219	226

The accessories

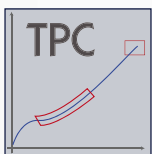
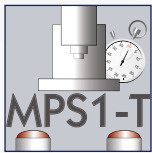
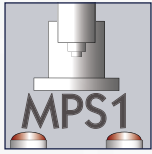

DAF direct-acting press cylinders with flange have been designed for flexible use in special machines. DAF press cylinders come with all the advantages of modern pneumatic presses as standard:

- ▶ Stepless adjustment of stroke length
- ▶ Adjustable end-position damping
- ▶ Tool mounting hole
- ▶ Easy to automate

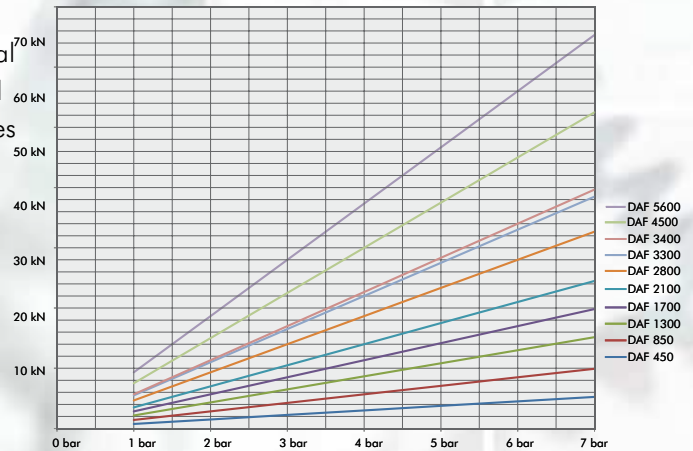

DAF 450
DAF 850
DAF 1300
DAF 1700

DAF 2100
DAF 2800
DAF 3400

DAF 1100
DAF 2200
DAF 3300
DAF 4500
DAF 5600

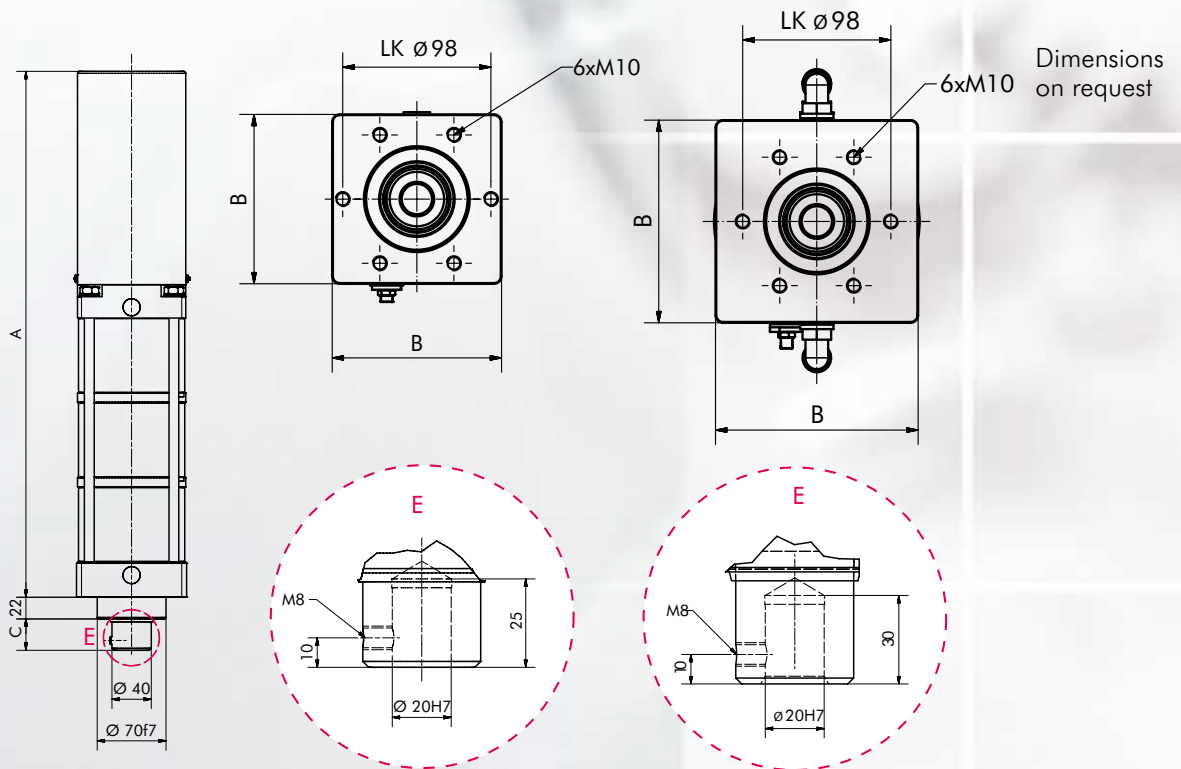

For details of fine stroke adjustment see page 31

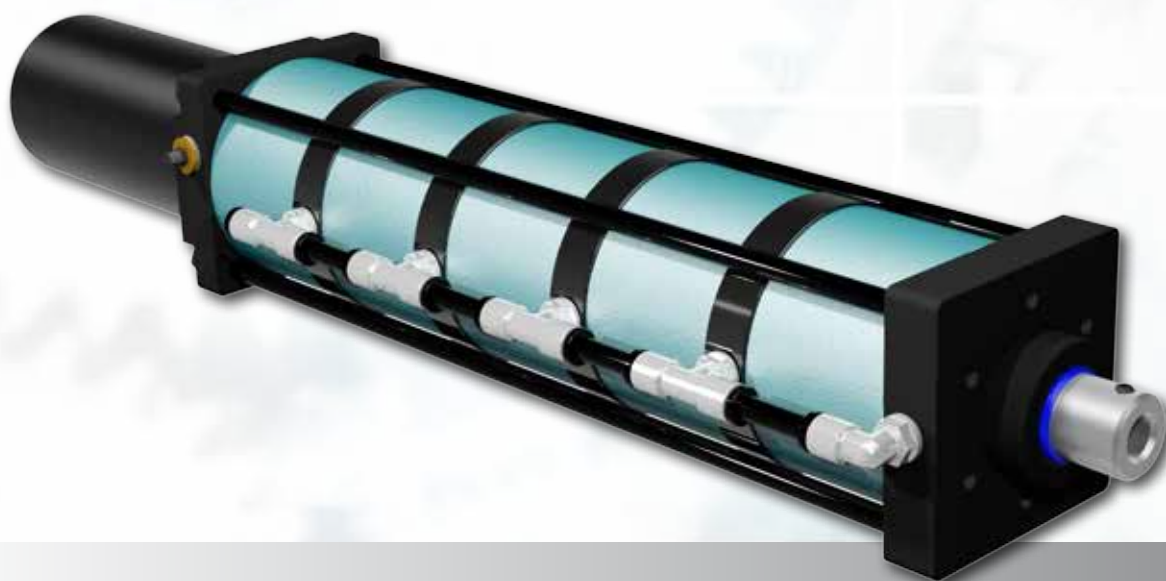

DAF cylinders

Type		DAF 450	DAF 850	DAF 1300	DAF 1700
Capacity at 6 bar	kN	4.5	8.5	13	17
Return force at 6 bar	kN	4	4	4	4
Stroke max.*	mm	40/60/80/100/120	40/60/80/100/120	40/60/80/100/120	40/60/80/100/120
A	mm	363	449	535	621
B	mm	112	112	112	112
C	mm	32	32	32	32

Type		DAF 2100	DAF 2800	DAF 3400
Capacity at 6 bar	kN	21	28	34
Return force at 6 bar	kN	20	27	33
Stroke max.*	mm	40/60/80/100/120	40/60/80/100/120	40/60/80/100/120
A	mm	581	689	797
B	mm	134	134	134
C	mm	38	38	38

Type		DAF 1100	DAF 2200	DAF 3300	DAF 4500	DAF 5600
Capacity at 6 bar	kN	11	22	33	45	56
Return force at 6 bar	kN	10	10	10	10	10
Stroke max.*	mm	40/60/80/100/120	40/60/80/100/120	40/60/80/100/120	40/60/80/100/120	40/60/80/100/120

* Specify the stroke length when ordering.

The accessories

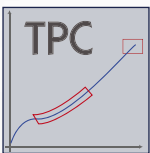
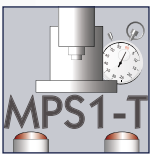
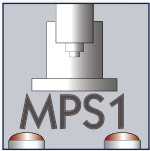
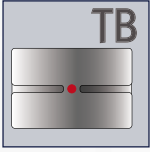

MicroPress® is a pneumatic press for smaller capacities with a robust press base. MicroPress® types are ideal for joining and shaping applications where components require low pressure and precise stroke depth. Examples are applications in medical engineering, electronics manufacturing and precision mechanics.

Quality features:

- ▶ Square ram
- ▶ Precision ram guide
- ▶ Adjustable stroke length
- ▶ Height-adjustable press head
- ▶ Practically maintenance-free cylinder
- ▶ Low noise

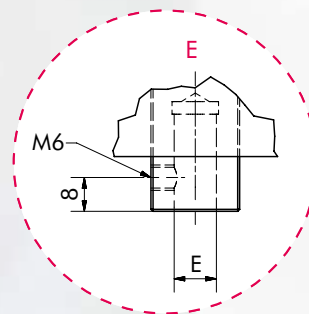
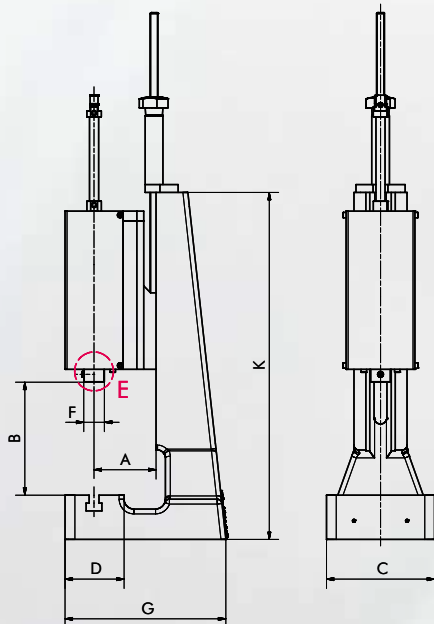
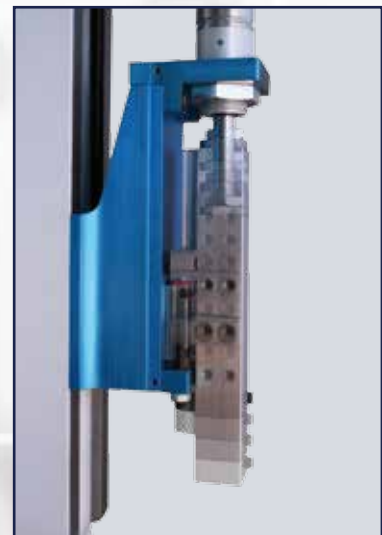
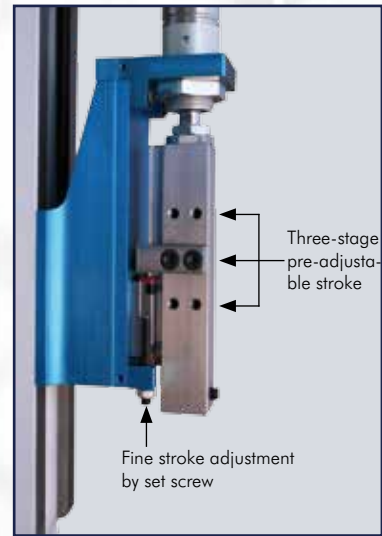
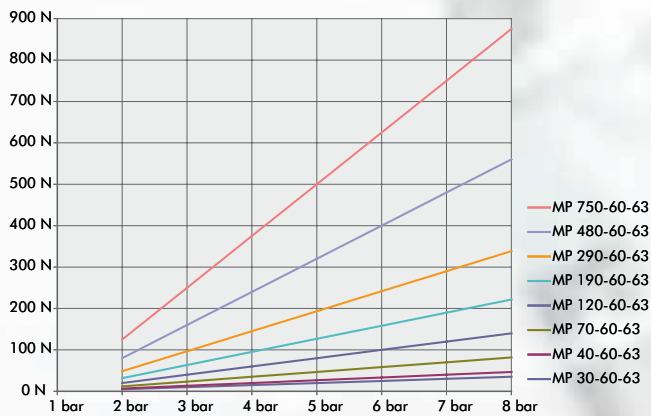



MicroPress 190-60-63

Type MicroPress			MP 30-60-63	MP 40-60-63	MP 70-60-63	MP 120-60-63	MP 190-60-63	MP 290-60-63	MP 480-60-63	MP 750-60-63
Capacity at 6 bar		N	30	40	70	120	190	290	480	750
Working stroke max.*		mm	60	60	60	60	60	60	60	60
Throat	A	mm	63	63	63	63	63	63	63	63
Daylight	B	mm	43 - 208	43 - 208	43 - 208	43 - 208	43 - 208	43 - 208	43 - 208	43 - 208
Table size	CxD	mm	100 x 65	100 x 65	100 x 65	100 x 65	100 x 65	100 x 65	100 x 65	100 x 65
T-slot width similar to DIN 650		mm	10	10	10	10	10	10	10	10
Ram bore Ø x Depth	E	mm	10 ^{H7} x 25	10 ^{H7} x 25	10 ^{H7} x 25	10 ^{H7} x 25	10 ^{H7} x 25	10 ^{H7} x 25	10 ^{H7} x 25	10 ^{H7} x 25
Ram Ø	F	mm	21 x 21	21 x 21	21 x 21	21 x 21	21 x 21	21 x 21	21 x 21	21 x 21
Air connection			M5	M5	M5	M5	G ₃ ''	G ₃ ''	G ₃ ''	G ₃ ''
Air consumption/ 60 mm stroke		l	0.04	0.06	0.08	0.16	0.24	0.38	0.64	1.0
Space requirement	CxG	mm	110 x 164	110 x 164	110 x 164	110 x 164	110 x 164	110 x 164	110 x 164	110 x 164
Stand height	K	mm	355	355	355	355	355	355	355	355
Weight		kg	ca. 9.5	ca. 10	ca. 10	ca. 11	ca. 11	ca. 12	ca. 12	ca. 12

Accessories (see Page 7)	Please specify when ordering.									
Table bore 12 ^{H7}	TB	TB	TB	TB	TB	TB	TB	TB	TB	TB

mäder hydropneumatic presses are initially driven by compressed air only and activate the hydraulic power stroke automatically. They combine the advantages of pneumatic and hydraulic presses. In the pneumatically driven fast stroke, the workpiece is approached rapidly with low force. The hydraulic power stroke is then activated automatically when resistance is encountered.

Because of this, the applied energy is used to the most economic effect particularly in these models. The operation of hydropneumatic presses is described on the following page. As **mäder** hydropneumatic presses do not need a hydraulic power pack, they can also be used where space is at a premium. All hydropneumatic presses can be provided with the standard **mäder** controller or with customer-specified controllers.

The processing of sheet metal, printed circuit boards and other bulky components requires presses to have a larger throat. XL-HP presses with 300 mm throat enable even these parts to be processed. For dimensions which lie outside the standard, presses with stands in welded design can be manufactured to your specifications.

Quality features:

- ▶ Anti-twist, hardened ram
- ▶ Long, honed ram guide for maximum precision
- ▶ Two power stroke lengths provided as standard
- ▶ Simple adjustment of the height of the press head using a threaded spindle and right-angle gearbox
- ▶ Side-mounted measuring strip for fast reproduction of settings when changing the tool
- ▶ Low noise: less than 75 dB

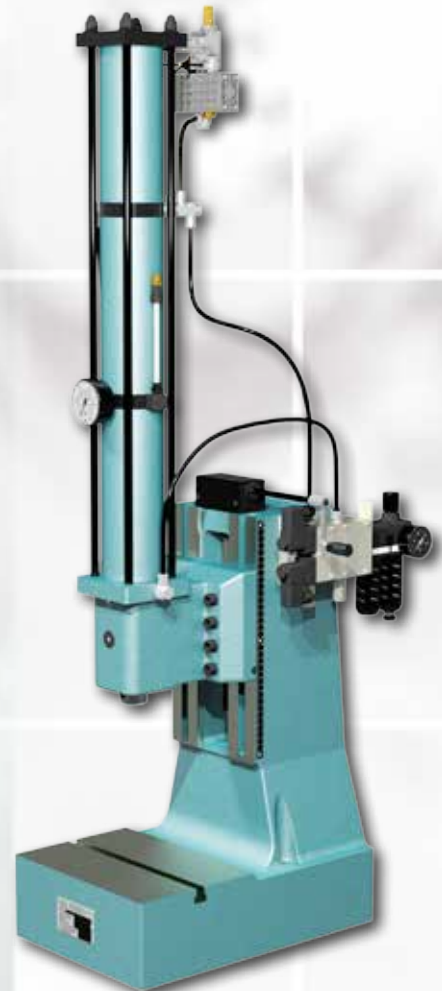

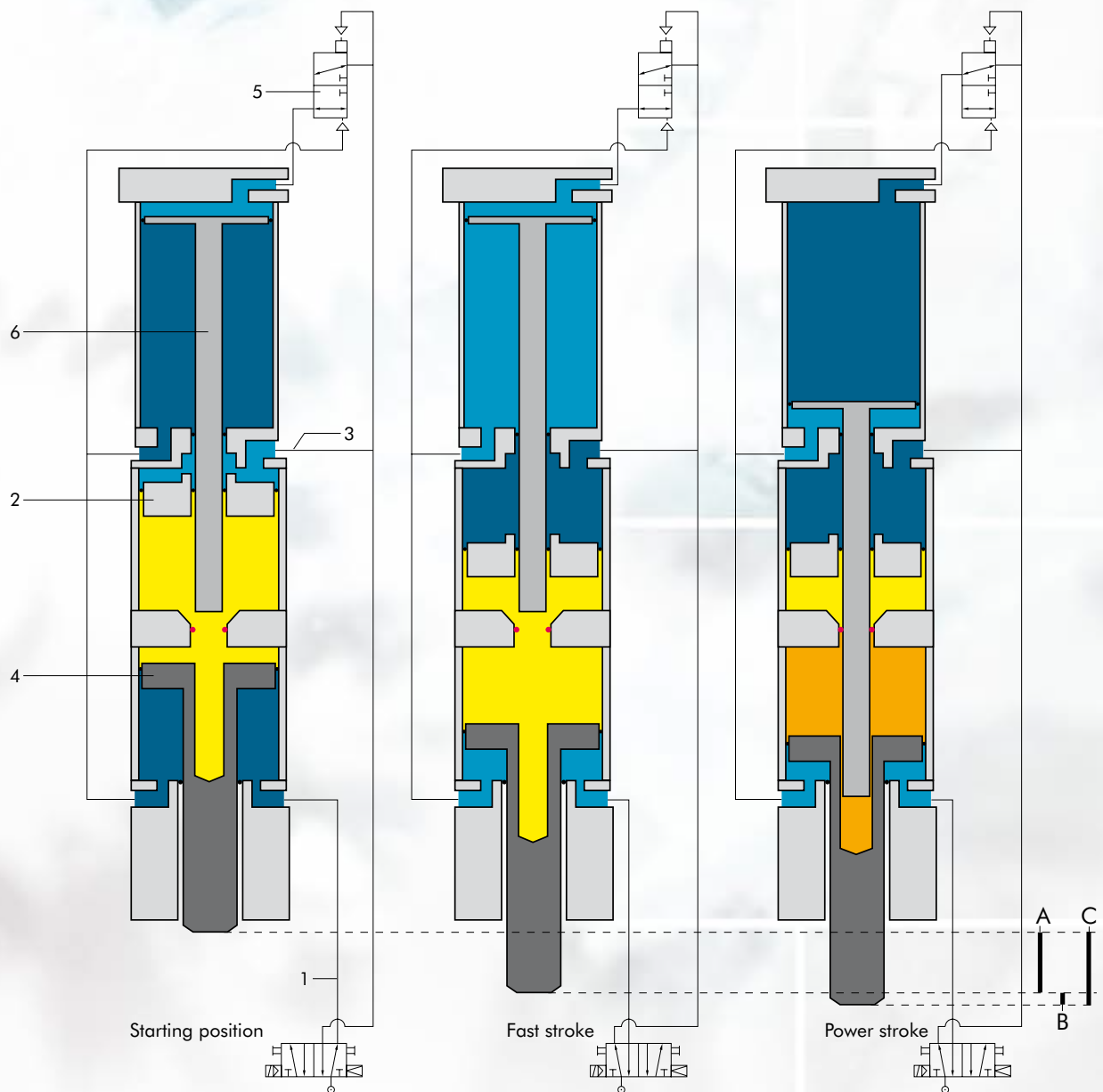

Description of operation:

Starting position:

Compressed air is applied to the compressed air line (1); the rest of the system is unpressurised.

Fast stroke (A):

Pressure is applied to the fast stroke piston (2) via the compressed air connection (3). The piston moves out and pushes the power stroke piston (4) down by means of the oil at high speed onto the workpiece.

- Oil without pressure
- Oil under pressure
- Air without pressure
- Air under pressure

- A = Fast stroke
- B = Power stroke
- C = Total stroke

Power stroke (B):

The changeover unit (5) now switches over automatically; the plunger (6) is pressurised with compressed air, moves out and closes the oil chamber causing the power transmission to take place. The ram (4) moves out at reduced speed and with increased force in the power stroke.

Return stroke (C):

System reversal; all pistons return simultaneously with pneumatic force.

The accessories

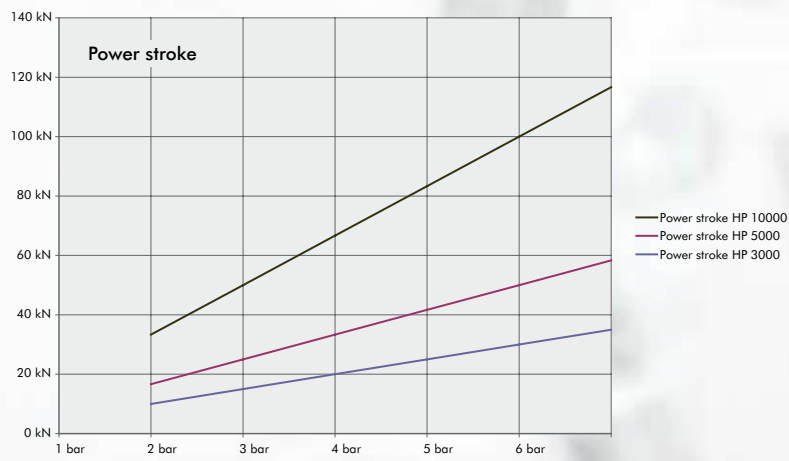
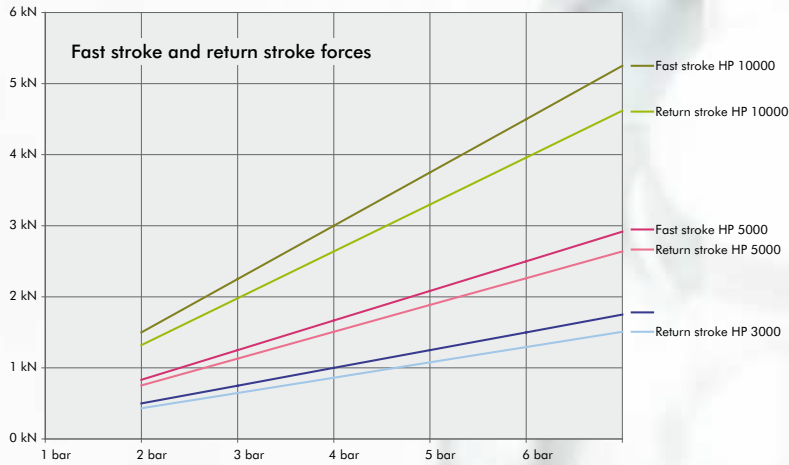
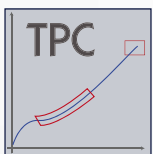
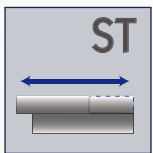
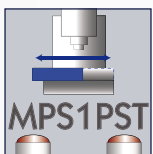
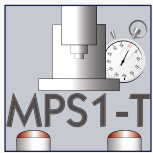
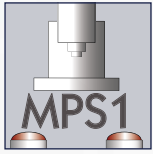

HP range

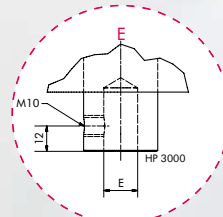
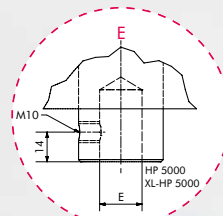
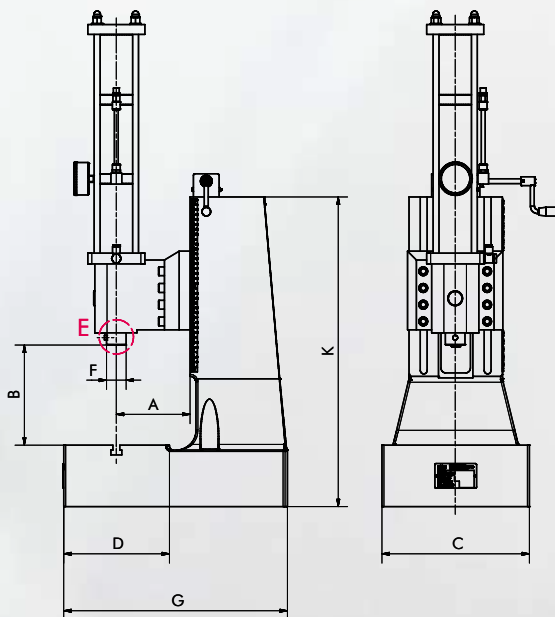

XL-HP range

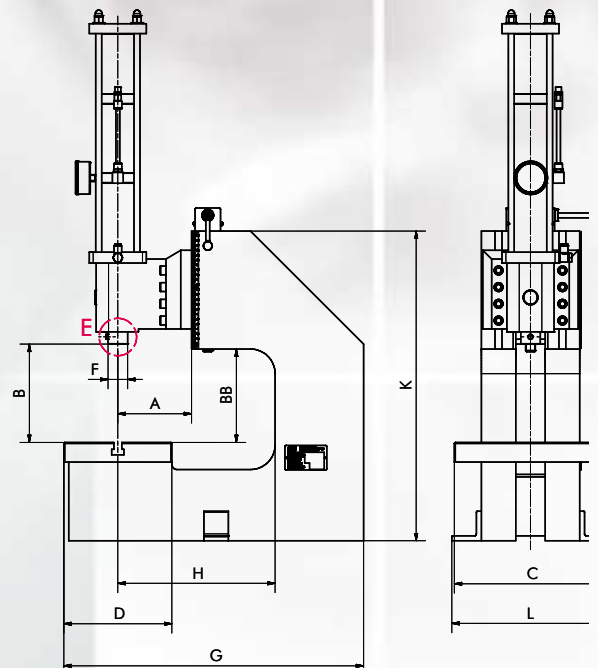

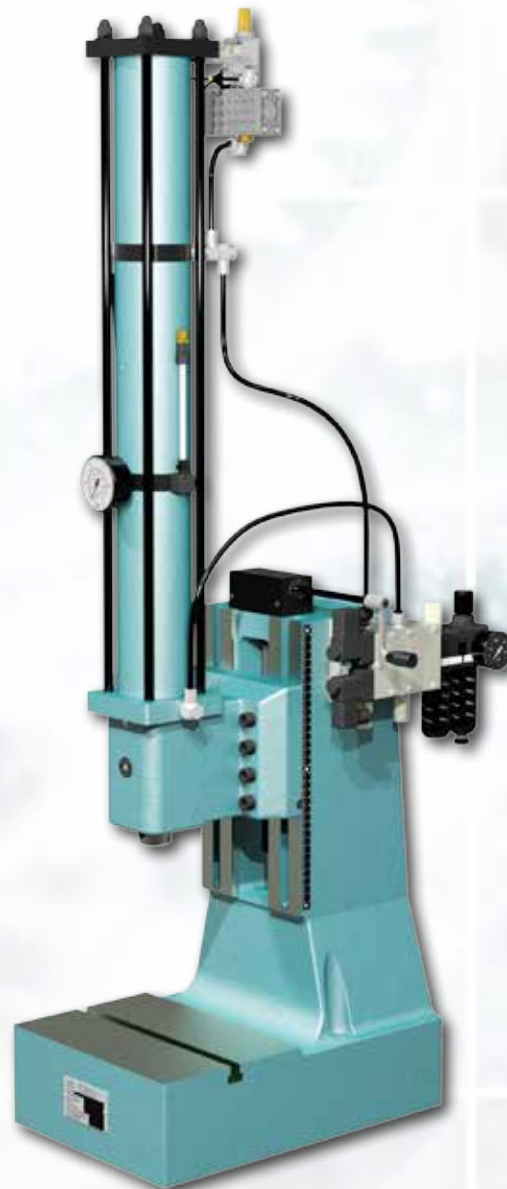

HP 5000 HV

Type		HP 3.000 HV	HP 5.000 HV	HP 10.000 HV	XL-HP 3.000 HV	XL-HP 5.000 HV	XL-HP 10.000 HV
Capacity at 6 bar	kN	30	42	100	30	42	100
Working stroke	mm	40	50	50	40	50	50
thereof power stroke*	mm	4/8	5/10	5/10	4/8	5/10	5/10
Capacity of rapid stroke 6 bar	kN	1.5	2.5	4.5	1.5	2.5	4.5
Capacity of return stroke 6 bar	kN	1.3	1.7	4.1	1.3	1.7	4.1
Throat	A mm	130	150	150	130	150	150
Throat C-frame	H mm	-	-	-	300	300	300
Daylight	B mm	140 - 385	119 - 320	117 - 312	200 - 327	145 - 235	200 - 270
Daylight C-frame	BB mm	-	-	-	158	190	190
Table size	CxD mm	200 x 190	300 x 210	310 x 220	200 x 220	310 x 220	310 x 220
T-slot width similar to DIN 650	mm	14	14	14	14	16	16
Ram bore Ø x Depth	E mm	16 ^{H7} x 30	20 ^{H7} x 34	20 ^{H7} x 34	16 ^{H7} x 30	20 ^{H7} x 34	20 ^{H7} x 34
Ram Ø	F mm	35	40	40	35	40	40
Air connection		G 1/4"	G 1/4"	G 1/4"	G 1/4"	G 1/4"	G 1/4"
Space requirement	LxG mm	200 x 385	300x455	310 x 500	200 x 560	320 x 610	320 x 610
Stand height	K mm	580	630	650	630	630	630
Weight	kg	ca. 78	ca. 163	ca. 287	ca. 184	ca. 241	ca. 311

* Specify the stroke length when ordering.

Valve and service unit only included with controller. Design may vary.

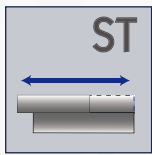

mäder pneumatic and manual side tables simplify manual and automatic insertion and therefore increase the economic efficiency of assembly processes.

The advantages:

- ▶ Insertion is carried out outside the danger area
- ▶ Parts can be preassembled spatially unhindered by the press
- ▶ Versatile options for automation and feed tasks
- ▶ Precise positioning of workpieces



MST 80
MST 100

Other quality features:

	MST 80	MST 100	MST 130	PST 130
Manual slide table	•	•	•	
Pneumatic slide table				•
Teflon slideway	•	•		
Hardened and ground guide columns	•	•		
Precision cross-roller guide with high loading capacity			•	•
Slideway adjustable without play			•	•
Installs transversely or longitudinally	•	•	•	•
Damping at both end positions			•	•
Self-latching in end position	•	•	•	•



MST 130



PST 130

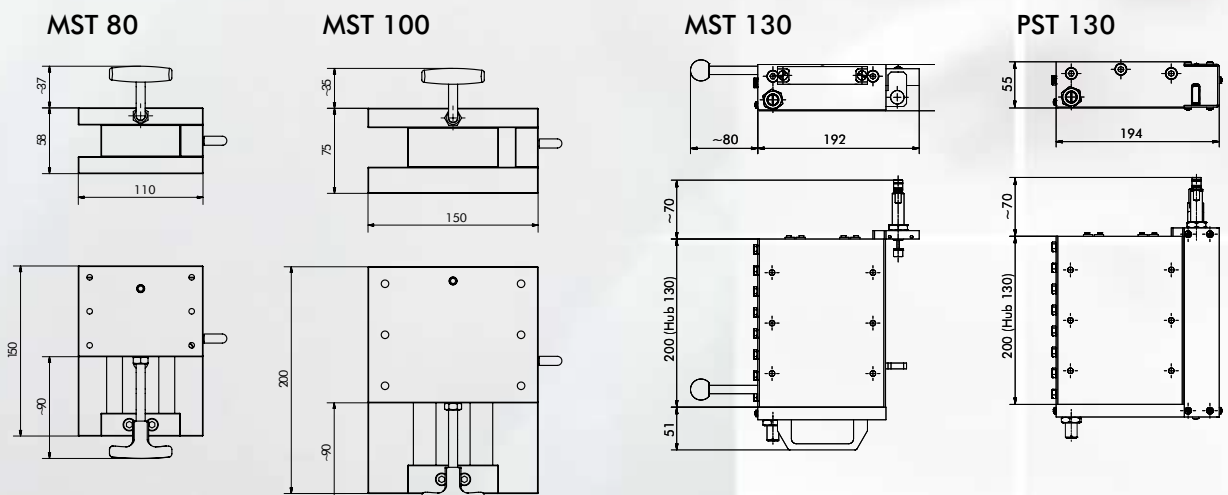

Installation examples



EP 500 with MST 80



DA type press with PST 130
Installation from the front



Installation from the side

mader pressen Slide tables

Type		MST 80	MST 100	MST 130	PST 130
Stroke	mm	80	100	130	130
Load capacity	kN	12	30	50	50
Suitable for presses with throat	mm	63/80	80/100	100/130/150/250/300	100/130/150/250/300

Press heads are components for automation or for special-purpose machinery construction. The press head from any press can therefore be purchased individually for an individualised installation. The need for complex and expensive one-off designs is thus avoided by the use of complete kits, and costs are lowered.



Press head of manual toggle press



Press head of rack and pinion press



Press head of pneumatic toggle press



Press head of direct-acting pneumatic presses

Press frame in welded design

So you've found a suitable press from our standard range, but the installation space underneath the press doesn't fit your fixture or your part? Just tell us what throat and what daylight range you need. We will make for you a press frame with the dimensions you specify, to which the required press head is then attached. Modifiable preliminary designs in our CAD library permit rapid and inexpensive manufacture.



Example of a press frame with increased daylight

Type MPS-1 controllers are type-tested and approved in accordance with the EC Machinery Directive 2006/42/EC to work with presses in workstations with manual loading and open tools. Here, safety is provided by the controller, which is designed to be both electrically and pneumatically redundant.

Type MPS-1 controllers comprise an electrical safety module with two-hand buttons and an electronic 5-digit parts counter. It is possible to switch from two-hand mode to an external start signal for the press, e.g. a foot switch, by means of a key-operated switch if a safe tool is used. The foot switch or equivalent is not included with the Type MPS-1 controller.

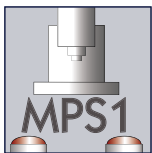

MPS-1
Basic version for two-hand operation.

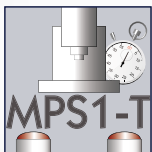

MPS-1 T
MPS-1 controller with additional stop time function. When the press has reached its end position, a timer can be used to determine when the return stroke should take place.

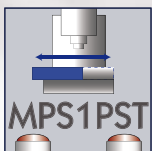

MPS-1 PST
This type of MPS-1 controller is used to control a pneumatic slide table in addition to the press. The scope of supply also includes the stop time function (see MPS-1 T)

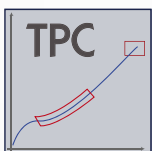

MPS-1 TPC
MPS-1 controller with an additional module TPC-MIDI for force/displacement monitoring.

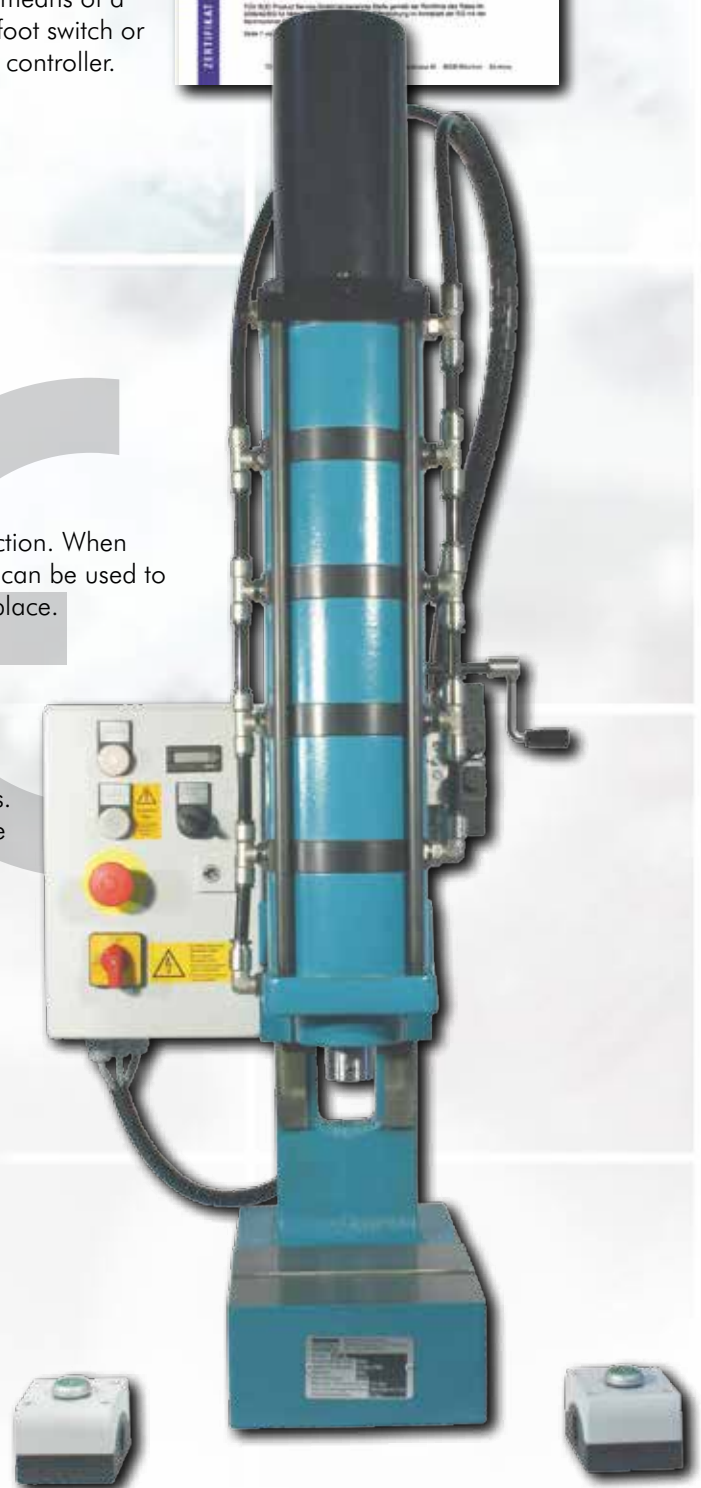

Applications:

Joining and assembly processes using presses must today be carried out safely and if possible without retrospective checking. Specified parameters which define the press process must be maintained during production. Only in this way can the quality and safety of the manufactured product be guaranteed. For this reason, TPC-MIDI is used wherever consistent joining processes are required, the progress of which has to be checked and if applicable documented by means of software.

TPC-MIDI monitors the press operation, compares the actual progress with the requirements and subsequently evaluates it. In this way, reject parts can be reliably detected and separated out.

TPC-MIDI can be used both with hand-operated presses and with pneumatic presses. In the case of pneumatic presses, the **MPS-1 TPC** controller is supplied together with a PLC onto which the type-tested two-hand MPS-1 safety controller is superimposed.

However, the TPC-MIDI is also available as a pure system component if a PLC environment already exists, e.g. in an automation system.

The advantages:

- ▶ TPC-MIDI can be programmed via the membrane keyboard or conveniently using the PC software.
- ▶ TPC-MIDI stores 8 different measuring programs
- ▶ 3 windows possible per program
- ▶ Modern curve evaluation via freely parameterisable windows
- ▶ 4 window types: insertion, pass-through and block windows as well as an envelope curve.
- ▶ Force measurement directly in the force characteristic with DMS sensor developed especially for presses.
- ▶ Software for programming and saving measuring programs
- ▶ Documentation of each press operation

Clear OK / NOK message

With OK parts, the indicator light is green and the press is ready for the next working stroke.

NOK parts are reliably reported by the TPC-MIDI as an audible signal and by a red indicator light.

The next press stroke cannot be initiated until the error has been acknowledged.



Laptop not included

DA 850-40-100 with MPS-1 TPC

System structure

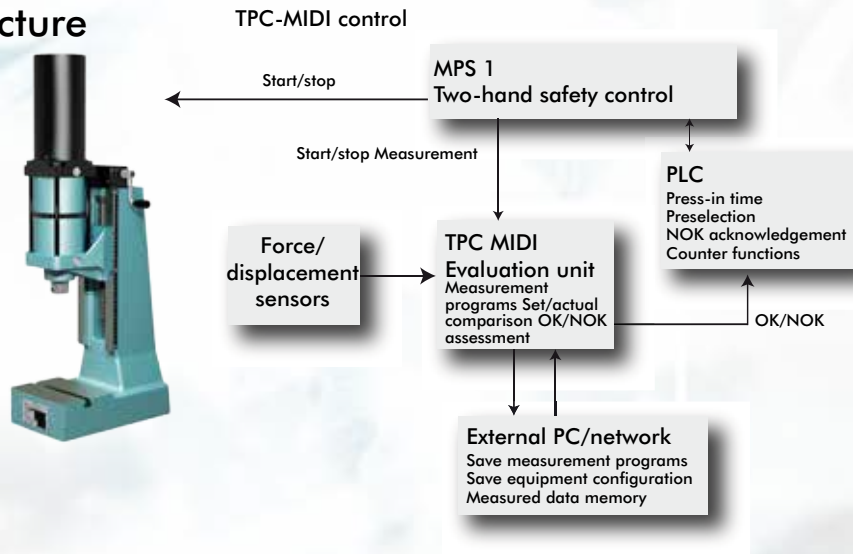

Load cell force sensors for TPC-MIDI

The load cell force sensor is fixed inside the ram bore. The tool holder can be fixed in the hole at the other end of the sensor. The force sensor is therefore always directly in the force flow between the press ram and the tool.

Measurement range	Measured value divergence	Tool holder
0 – 500 N	≤ ± 0.5% of EV	10H7 x 24 mm
0 – 1 kN	≤ ± 0.5% of EV	10H7 x 24 mm
0 – 2 kN	≤ ± 0.5% of EV	10H7 x 24 mm
0 – 5 kN	≤ ± 2.0% of EV	10H7 x 24 mm
0 – 10 kN	≤ ± 2.0% of EV	10H7 x 24 mm
0 – 20 kN	≤ ± 1.0% of EV	10H7 x 24 mm
0 – 50 kN	≤ ± 1.0% of EV	20H7 x 24 mm
0 – 100 kN	≤ ± 1.0% of EV	20H7 x 24 mm

Unless expressly required to the contrary, the load cell force sensor is selected to match the maximum capacity of the press used



Potentiometric travel meter

Travel is measured potentiometrically. The service life of the sensors is 10⁸ movements

Press stroke	Resolution	Linearity error
40 mm	0.025 mm	0.42%
60/80 mm	0.038 mm	0.41%
100 mm	0.050 mm	0.40%
120 mm	0.075 mm	0.40%

Monitoring windows

Pass-through window

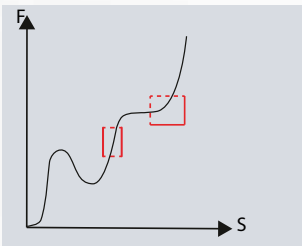

The force/displacement curve must pass through the window from the entry to the exit side as defined without one of the other window boundaries being infringed. The entry and exit sides can be freely selected.

Block window

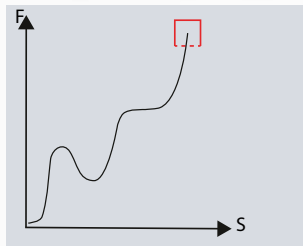

The block window monitors the final values of the press operation. With this type of window, the force/displacement curve must enter the specified entry side and must not leave the window again.

Envelope curve

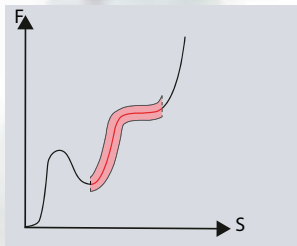

The measuring curve must pass continuously through the envelope curve and must not infringe it. The envelope curve is taught by means of a teach-in process. Its X-axis parameters and the delta-Y, i.e. the force tolerance range, are then defined.

Monitoring window

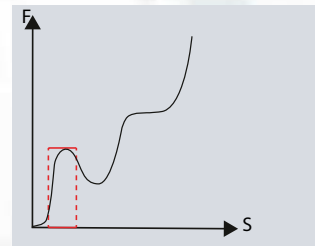

With this window, it is possible to monitor at the start of the press-in process whether parts become jammed or are not correctly inserted. If the force rises too steeply, the window is exited upwards and a real-time signal is generated that can be used to abort the process.

The reference points of the monitoring windows

The reference points of the monitoring windows on the X-axis can be defined both rigidly and dynamically.

Absolute

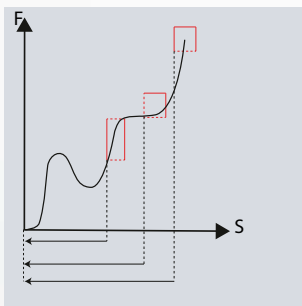

In the case of assembled parts with high repeat accuracy, the calibrated zero point of the displacement sensor on the X-axis is used as the reference point.

Trigger

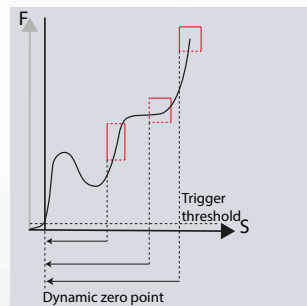

If the assembly sequence is identical as such, but the start of assembly has a major deviation on the X-axis, the beginning of the measurement can be defined by setting a trigger threshold on the Y-axis.

End force

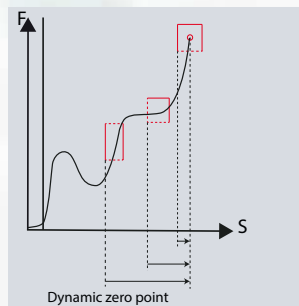

If a measurement with an absolute or a trigger reference point is not useful, the position of the end force (Fmax) on the X-axis can be selected as the reference point. The position of the evaluation window on the X-axis then relates in reverse to this dynamic zero point.

Block window

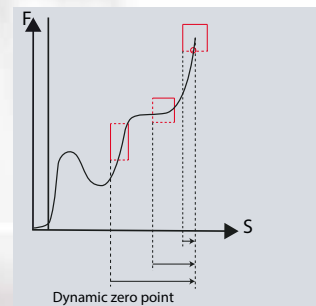

If the end force shows a wide spread, the reference point of the evaluation windows can also be defined using the entry of the curve into the block window. Any values after the block window has been reached are no longer taken into account. The position of the evaluation windows on the X-axis then relates in reverse to this dynamic zero point.

PC Software

TPC-MIDI is supplied as standard with the basic version of the software, with which the configuration of TPC-Midi and measurement programs can be set up and saved.

Equipment configuration

- ▶ Settings or teach-in of the force and displacement sensors (X/Y axes)
- ▶ Stipulation of measurement method and reference points

Measurement programs

- ▶ Creation and internal saving of 8 measuring programs. Further measurement programs can be created, saved and reloaded when required.
- ▶ Input of sets of curves
- ▶ Creation of monitoring windows and envelope curve
- ▶ Test runs with OK or NOK assessment

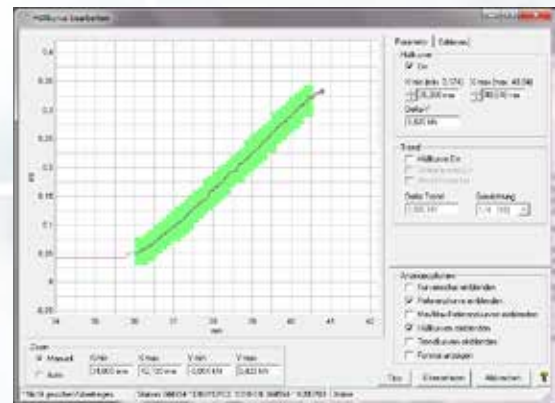
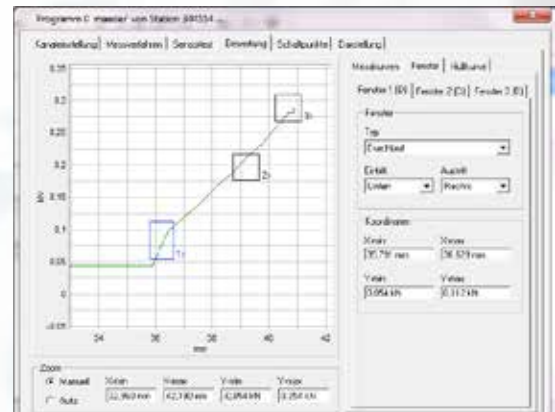

With the licensed full version, the production data per press-in operation can be recorded in addition.

- ▶ Production mode
- ▶ Measured data recording
- ▶ Clear-cut part reference
- ▶ Besides the program's own format, export in ASCII and Excel

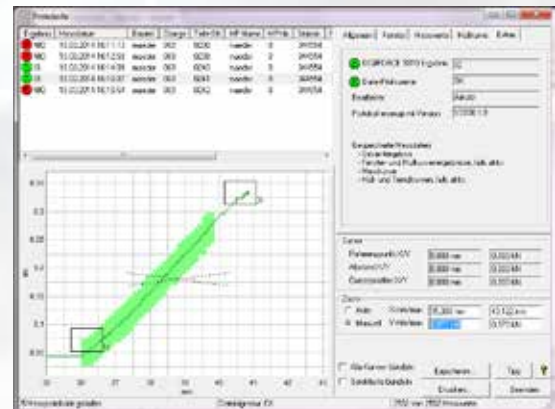

The Press & Tool Concept was developed in Switzerland by a renowned press manufacturer, and was taken over and perpetuated by **mäder** presses in 2008. It now represents Swiss technology made in Germany.

The Press & Tool Concept represents a well-rounded press and tool program for efficient manufacturing, particularly in the sheet metal processing industry, in force ranges from 10 kN - 35 kN.

Quality features:

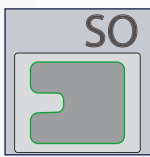

SOLID FRAME

Solid cast frames in C-design with high stability and low resilience for punching operations enable cost-effective free-cutting tools to be used in many working processes.

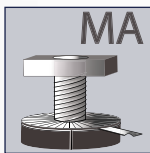

MICRO ADJUST

The precision height adjustment of the press table simplifies the set-up of Press & Tool Concept presses and increases their application possibilities. The standard scale disc enables a reading accuracy of 0.1 mm.

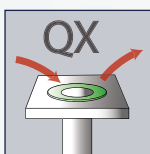

QUICK TOOL CHANGE

The standardised tool fixing system enables the different tools of the Press & Tool Concept to be changed in next to no time.

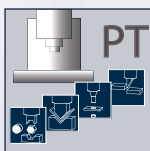

TOOL SYSTEM

Basic tool system for standard sheet metal processing applications such as punching, 90° bending, radial punching etc.

The components of the Press & Tool Concept

Hand-operated toggle presses

Pneumatic toggle presses



KP 2.1 N
KP 2.1 N Vario

KP 2.1 W
KP 2.1 W Vario



KP 3.1 N



KP 3.1 W

Tool system

Punching tool	Strip cutting tool	Angle separating tool	Profile rail punch with 10 plug-in centring inserts
Profile cutting tool	Bending tool	Rotatable radius punch	Combination corner punch

Standard stop, bar design Type: Z-100	Standard stop, plate design Type: Z-101	Coordinate stops
X-axis 250 mm without scale Y-axis 40 mm without scale	X-axis 250 mm without scale Y-axis 40 mm without scale	X-axis 300 mm Z-110-300 X-axis 520 mm Z-120-520 Y-axis 120 mm Z-111-120 Y-axis 255 mm Z-121-255

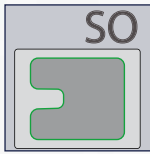

The standard toggle press of the Press & Tool Concept

Ideal for punching, bending, assembly, embossing, pressing, riveting, straightening, gluing.

- ▶ Simple handling
- ▶ Factory-set end position with high repeat accuracy
- ▶ The MICRO ADJUST system enables the press table to be quickly and accurately adjusted in height
- ▶ Reading accuracy 0.1 mm
- ▶ Fixing by means of quick-clamp lever without additional tools
- ▶ Ideal in conjunction with the W 14 tool system
- ▶ Adapter piece included

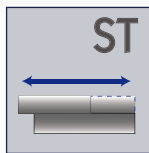
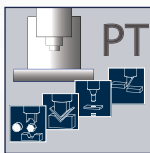
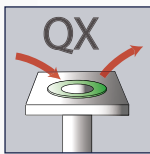
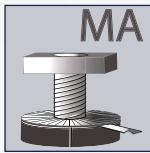

Fitted stripper frame (special accessory)

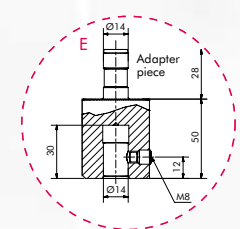
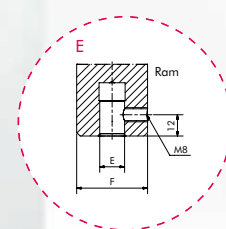
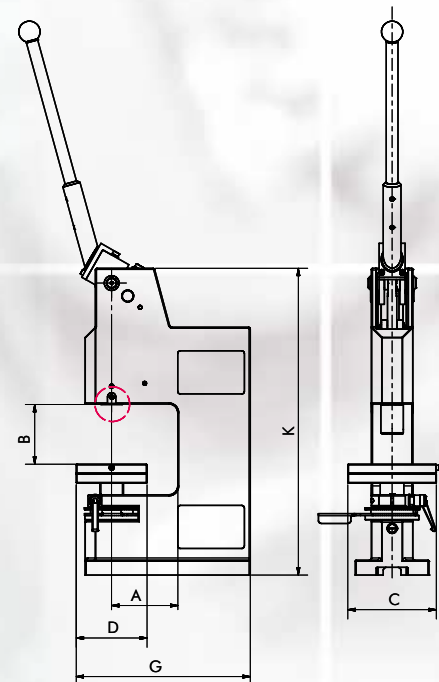
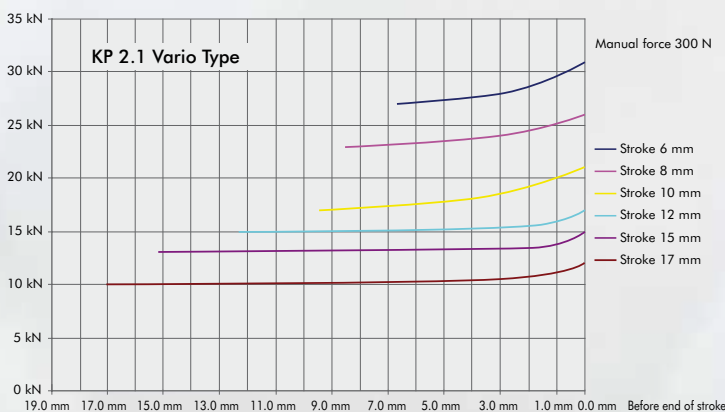
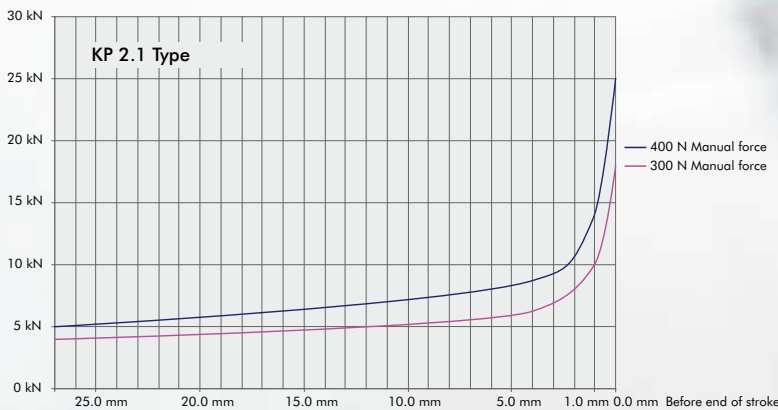



KP 2.1 N



KP 2.1 N Vario

Type			KP 2.1 N	KP 2.1 W	KP 2.1 N Vario	KP 2.1 W Vario
Capacity		kN	25	25	10 - 30	10 - 30
Working stroke		mm	27	27	6 - 17	6 - 17
Throat	A	mm	112	275	112	275
Daylight max.	B	mm	122	122	112	117
Table traverse		mm	70	70	70	70
Table size	D x C	mm	120 x 150	120 x 150	120 x 150	120 x 150
Ram bore Ø x Depth	E	mm	14 ^{H7} x 30	14 ^{H7} x 30	14 ^{H7} x 30	14 ^{H7} x 30
Ram Ø	F	mm	40 ^{H7}	40 ^{H7}	40 ^{H7}	40 ^{H7}
Space requirement	C x G	mm	125 x 280	125 x 520	125 x 280	125 x 520
Stand height	K	mm	520	520	520	520
Weight		ca. kg	35	85	35	85

KP hand-operated toggle presses

The accessories

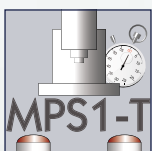
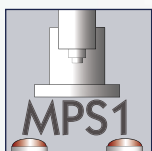
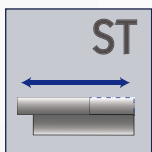
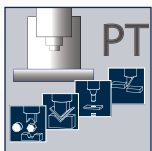
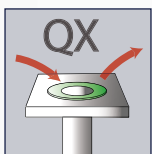
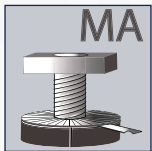
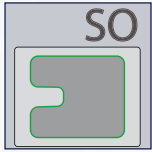

The pneumatic toggle presses of the KP 3.1 range

- ▶ Driven by double-acting pneumatic cylinders
- ▶ Factory-set end position with high repeat accuracy
- ▶ Anti-twist ram
- ▶ Adapter piece for bridging working height as standard
- ▶ The stroke limit allows the user to set up a low stroke length for safe working
- ▶ The MICRO ADJUST system enables the press table to be quickly and accurately adjusted in height
- ▶ Reading accuracy 0.1 mm
- ▶ Anti-twist
- ▶ Ideal in conjunction with the W 14 tool system
- ▶ Adapter included

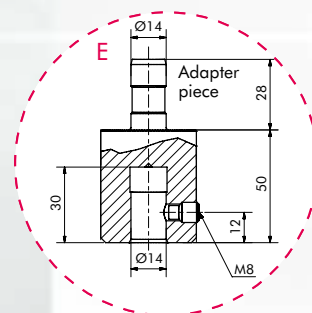
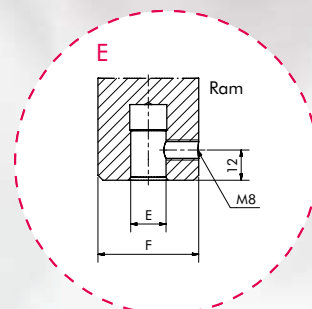
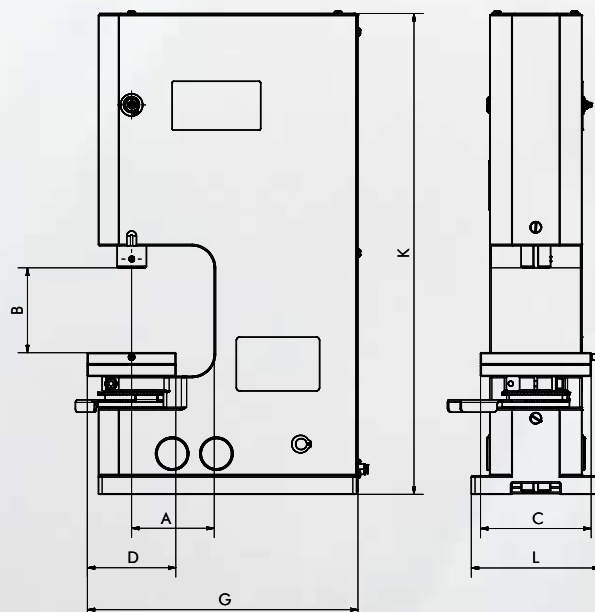
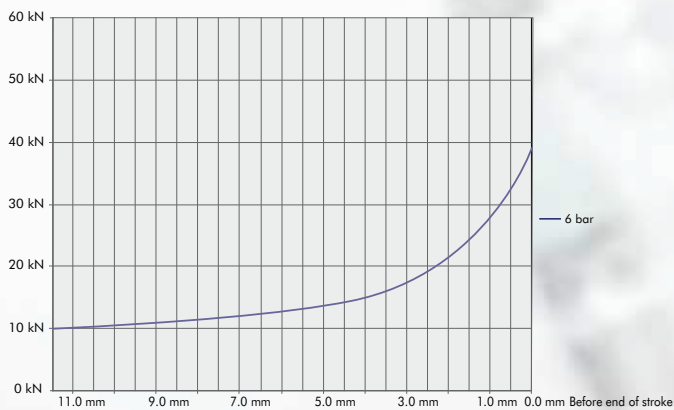



KP 3.1 N



KP 3.1 W

Type			KP 3.1 N	KP 3.1 W
Capacity at 6 bar		kN	35	35
Working stroke		mm	6 - 27	6 - 27
Throat	A	mm	112	275
Daylight	B	mm	55 - 145	55 - 145
Table size	D x C	mm	120 x 150	120 x 150
Ram bore Ø x Depth	E	mm	14 ^{H7} x 30	14 ^{H7} x 30
Ram Ø	F	mm	40 ^{H7}	40 ^{H7}
Air connection			G 1/4"	G 1/4"
Air consumption/stroke		l	7.1	7.1
Space requirement	C x G	mm	175 x 350	175 x 565
Stand height	K	mm	650	720
Weight		kg	75	125

Valve and service unit only included with controller. Design may vary.

Calculating the shear forces

The force required for punching is calculated from the following quantities:

$\tau_{\alpha Bmax}$ = Shear strength of the material in N/mm²

l = Length of cut edge in mm

s = Material thickness in mm

When the cutting edges of the stamp and die are parallel, the required shear force is calculated as follows:

$$F = \tau_{\alpha Bmax} \cdot l \cdot s$$

Calculation example:

Punching a hole \varnothing : 8.5 mm in 1.5 mm thick
AlMg 5 half-hard

($\tau_{\alpha Bmax} = 240 \text{ N/mm}^2$)

$$F = 8.5 \text{ mm} \cdot \pi \cdot 1.5 \text{ mm} \cdot 240 \text{ N/mm}^2$$

$$F = 9608.4 \text{ N} \sim 9.6 \text{ kN}$$

The required cutting force can be reduced by angled or serrated cutting.

Cutting clearance:

As a rule of thumb, it can be assumed that the cutting clearance should be 10% of the material thickness s . The W 14 tool system is supplied with a standard cutting clearance of 0.1 mm. The cutting clearance must be modified particularly in the case of soft materials, plastics and thin foils.

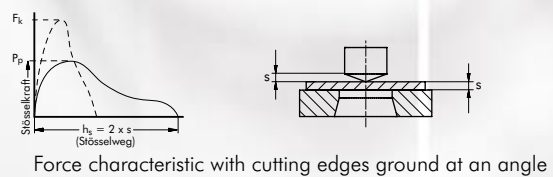
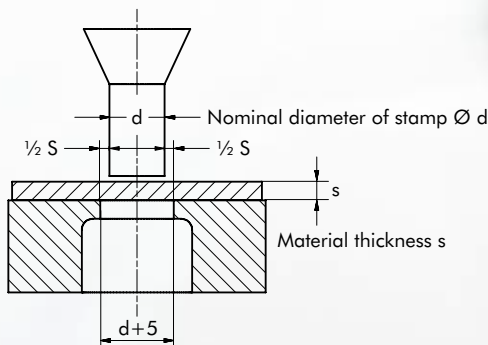

Selection of materials with shear strength $\tau_{\alpha Bmax}$ in N/mm ²						
Aluminium	Al 99 soft	60 - 80	Heat-treated steel	Ck 22	340 - 400	
	Al 99 half-hard	60 - 100		Ck 35	400 - 480	
Alu alloys	Al Mo 3 soft	150 - 200		Ck 45	480 - 580	
	Al Mg 5 soft	190 - 210		Ck 60	560 - 680	
	Al Mg 5 half-hard	200 - 240		Stainless steel	V2A	600 - 900
	Al Mg 7 soft	240 - 280		Spring steel, hard		800 - 1200
	Al Mg 7 half-hard	280 - 320		Brass	Ms 58	300 - 450
Fine steel sheet	T St 10	220 - 400	Copper	Cu	200 - 230	
	U St 12	220 - 340	Polyvinyl chloride, soft	PVC 1	20 - 180	
	U St 14 2	80 - 320	Polyvinyl chloride, hard	PVC	160 - 250	
Structural steel	St 37	300 - 360	Epoxy (print material)		180 - 300	
	St 50	400 - 480	Laminated paper		70 - 90	
	St 60	480 - 580				
	St 60	480 - 580				
	St 70	560 - 680				

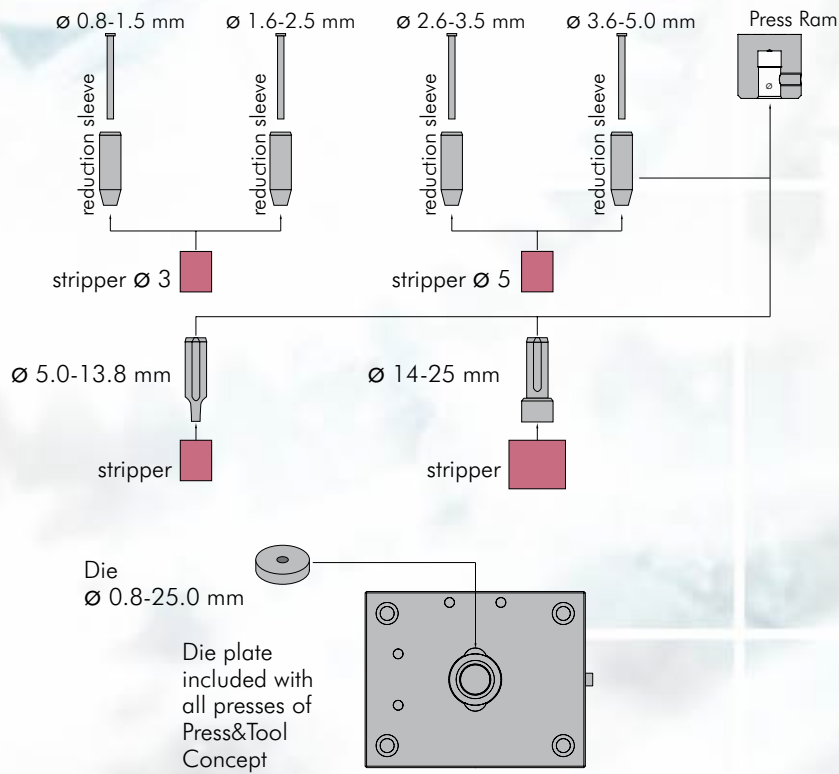

Round hole tools $\varnothing 0.8 - 5$ mm				
	$\varnothing 0.8 - 1.9$	$\varnothing 2.0 - 2.9$	$\varnothing 3.0 - 3.9$	$\varnothing 4.0 - 4.9$
	stamp step grade 0.1 mm	stamp step grade 0.1 mm	stamp step grade 0.1 mm	stamp step grade 0.1 mm
	reduction sleeve	reduction sleeve	reduction sleeve	reduction sleeve
	stripper	stripper	stripper	stripper
	die	die	die	die

Round hole tools $\varnothing 5 - 13.8$ mm	
	stamp step grade 0.0/0.2/0.5/0.8 (5.0) to (13.8)
	stripper red (spring range 33%) brown (spring range 20%)
	die W 14-3550 to W 14-35138

Round hole tools $\varnothing 14 - 25$ mm	
	stamp step grade 0.0/0.2/0.5/0.8 (5.0) to (13.8)
	stripper red (spring range 33%) brown (spring range 20%)
	die W 14-3550 to W 14-35138

Slot cutting fittings	
	stamp step grade 0.0/0.2/0.5/0.8 (5.0) to (13.8)
	stripper red (spring range 33%) brown (spring range 20%)
	die

Square and rectangular cutting fittings	
	stamp step grade 0.0/0.2/0.5/0.8 (5.0) to (13.8)
	stripper red (spring range 33%) brown (spring range 20%)
	die

CONTACT

CONTACT

made in Germany by:

mäder
pressen

mäder pressen GmbH

Robert-Bosch-Str. 13

78579 Neuhausen ob Eck

Germany

Tel.: +49 (0) 74 67 - 94 67 - 0

Fax: +49 (0) 74 67 - 94 67 - 50

info@maederpressen.de

www.maederpressen.de

