

INSTRUCTION MANUAL

MIXPROOF BZAW Valve

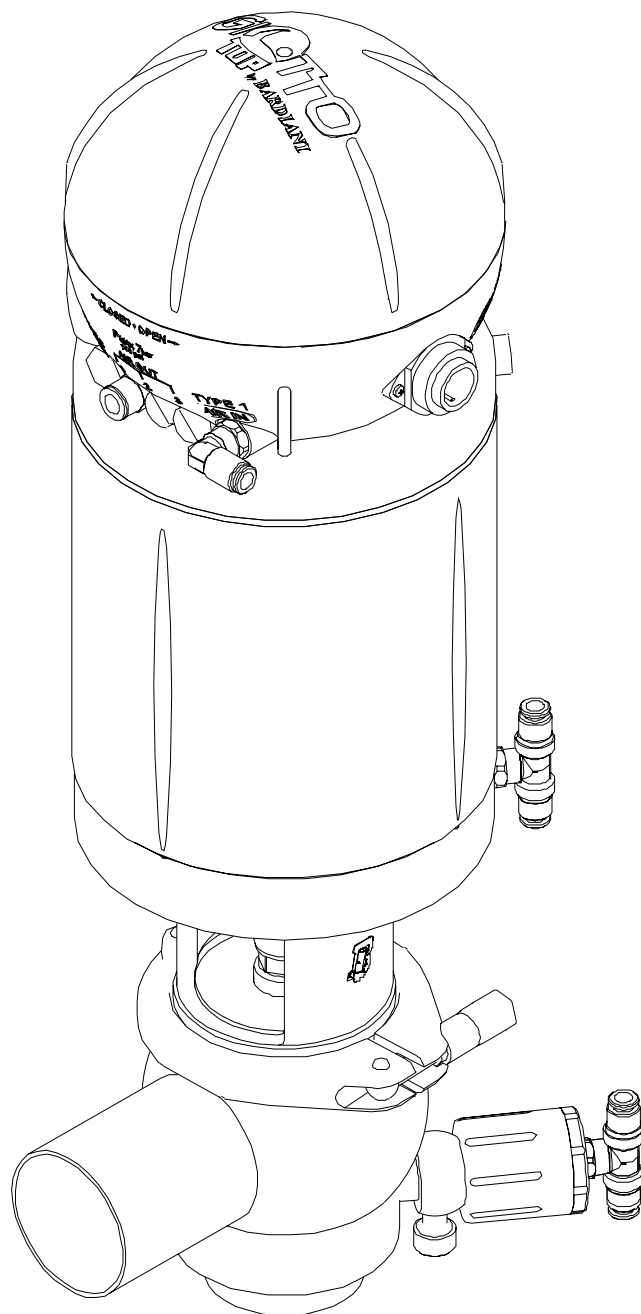

BARDIANI
VALVOLE

1. Safety signs	3
2. General safety precautions	3
3. Receiving/Unpacking/Storage.....	4
4. Installation.....	5
5. Operation	7
6. Troubleshooting	8
7. Cleaning.....	9
8. General maintenance.....	10
9. Planned maintenance	11
10. Spare parts ordering	12
11. Disassembly of ZAW (25--100).....	13
Drawings ZAW	16
12. Assembly of ZAW (25--100).....	18
13. Disassembly of ZAW (25--100) divert.....	20
Drawings ZAW divert	23
14. Assembly of ZAW (25--100) divert.....	25
15. Parts list	28
16. Technical data	29
Warranty.....	30
Disclaimer	30

Foreword

This instruction manual is an integral part of the valve delivery.

- **To use the Atex valve model is obligatory to consult the appropriate manual.**
- **Always read it carefully before using the valve.**
- **Always keep it for future reference.**

All rights are reserved. It is forbidden to reproduce or transit any part of the instruction manual by any means, either electronic or mechanical, including photo copies, recording or any other memorisation or retrieval system for purposes other than the exclusively personal use by the purchaser – without prior written permission by the manufacturer.

This instruction manual is expressly intended for use by technicians. Therefore, some information which can easily be inferred by reading the text and examining the illustrations and drawings has not been further specified. The publisher is not responsible for any consequences of incorrect operations by the user.

The data and information in this instruction manual are subject to modifications or updates without any further notice or obligations on the part of the manufacturer.

1. Safety/Caution Signs



General WARNING sign, which indicates that special instructions **MUST** be followed to avoid serious personal injuries.



General CAUTION sign, which indicates that special instructions **MUST** be followed to avoid damage of equipment and environment.

NOTE!

Indicates **IMPORTANT** information, which improves the understanding of the instructions.

2. General Safety Precautions



ALWAYS read the technical data before installation, operation and maintenance.

ALWAYS use authorised personal to install, operate and service the valve. The personal should know the valve and the instruction manual thoroughly.

ONLY use the valve for the designed purpose.

ALWAYS handle heavy valves carefully and use lifting tools where necessary.

ALWAYS pay attention to possible loose valve parts when unpacking the delivery.

ALWAYS connect air supply carefully and disconnect after use.

ALWAYS connect electrical supply carefully and disconnect after use.

NEVER touch moving valve parts.

NEVER touch a hot valve.

ALWAYS handle cleaning agents carefully.

NEVER remove a valve from piping or disassemble it when the valve or piping are pressurised.

**We cannot be held responsible for incorrect installation,
operation and maintenance!**

3. Receiving/Unpacking/Storage

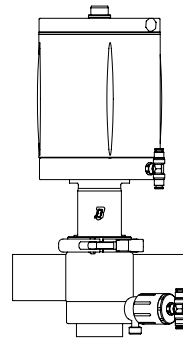
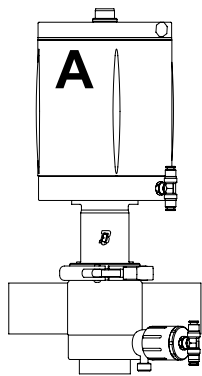

**BZAW
MIXPROOF**

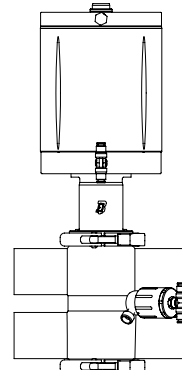

**BZAW
MIXPROOF M8**

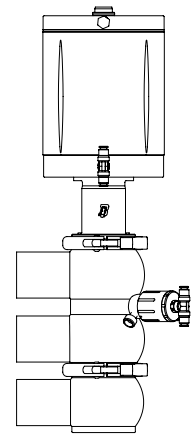

**BZAW MIXPROOF
M8 DIVERT**

ATTENTION !

1. UNPACK AND CHECK VALVE DELIVERY:

- A. Complete valve
- B. Instruction manual

2. IDENTIFY VALVE TYPE SUPPLIED:

BZAW: Pneumatic Mixproof

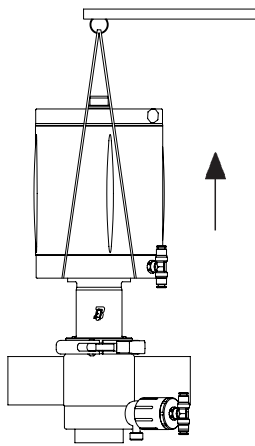

3. LIFTING OF HEAVY VALVE:

- Use lifting tool, if necessary.
- Fix valve to lifting tool.

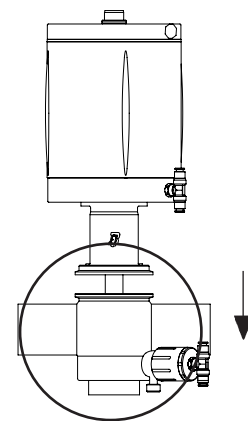

4. HANDLING OF LOOSE VALVE PARTS:

- Avoid falling loose valve parts.
- Assemble and tighten loose parts.

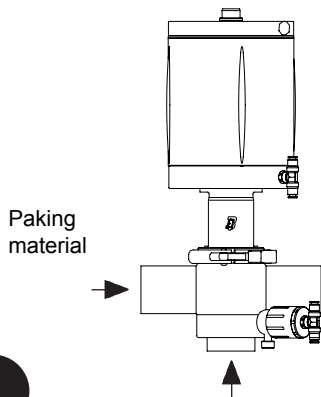

Packing material

- Opening
- Air connections
- Electrical connections (for Giotto Top®)

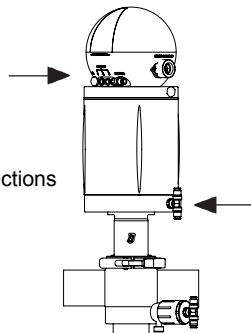

Safe valve protection!

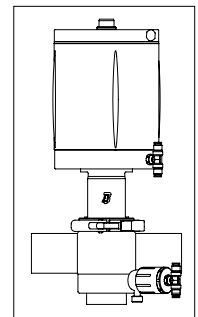

5. PACKING MATERIAL:

- Inspect internal of valve.
- Remove material and dispose of according to current directives.

6. INSPECTION/CLAIM:

- Inspect valve connections.
- Document /verify damage, missing or wrong parts.
- Use current claim procedure if necessary.

7. STORAGE/PROTECTION:

- Avoid dust, humidity, wet areas, heat and similar.
- Avoid vibration.
- Min.: - 10 °C
- Max.: + 50 °C

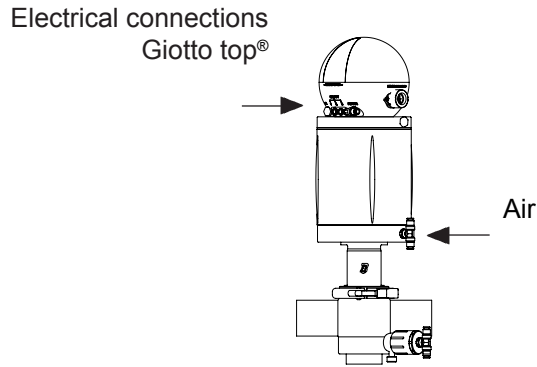

1. CONNECTION OF AIR AND EL SUPPLY

- Use authorised personnel to install/connect the valve.
- Ensure correct air pressure and quality (see page 25).
- Ensure correct electrical supply for Giotto Top® (see Giotto Top® instruction manual).

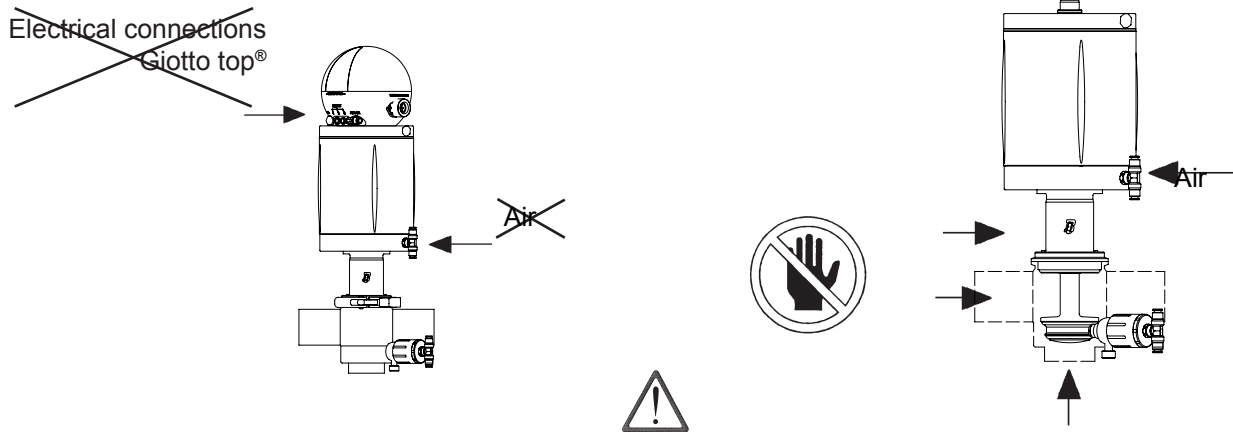

2. DISCONNECT SUPPLIES AFTER USE:

- Disconnect air supply.
- Disconnect electrical supply (for Giotto Top®).

3. MOVING VALVE PARTS:

- Never stick fingers into valve ports.
- Never touch moving valve shutter/stem.

Damage risk!

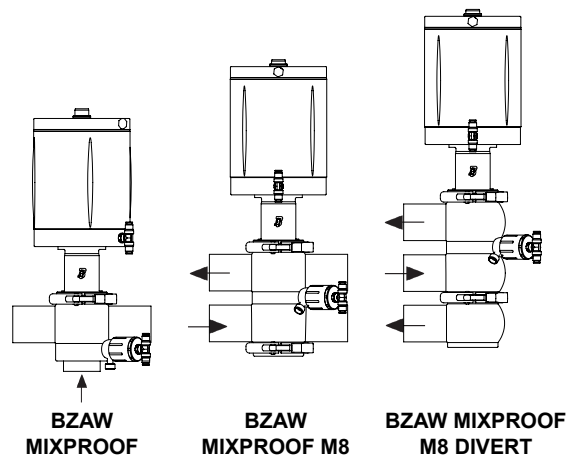
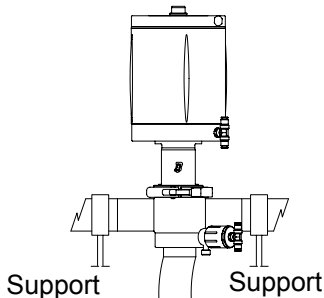

4. AVOID VALVE OVERLOADING AND COMPENSATE FOR:

- Vibration
- Thermal expansion

5. CORRECT FLOW DIRECTION:

If possible, have flow against valve closing direction to avoid or minimise water hammer.

4. Installation

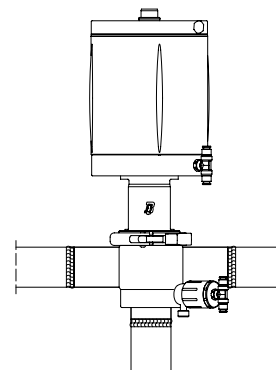
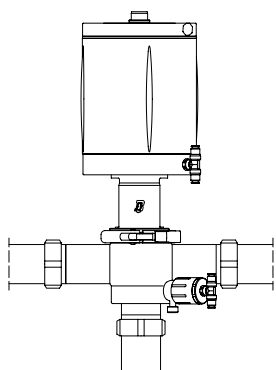

6. VALVE CONNECTIONS/UNIONS:

- Ensure tight connections between valve and piping.
- Remember gaskets and fit correctly.
- Tighten unions firmly and carefully.

7. WELDING VALVE BODY INTO PIPING:

- Remove inner valve parts.
- Weld body carefully into piping.
- Assemble valve.
- See assembly instructions.

Valve dimension	A (mm)
DN25	275
DN40	295
DN50	310
DN65	325
DN80	340
DN100	360

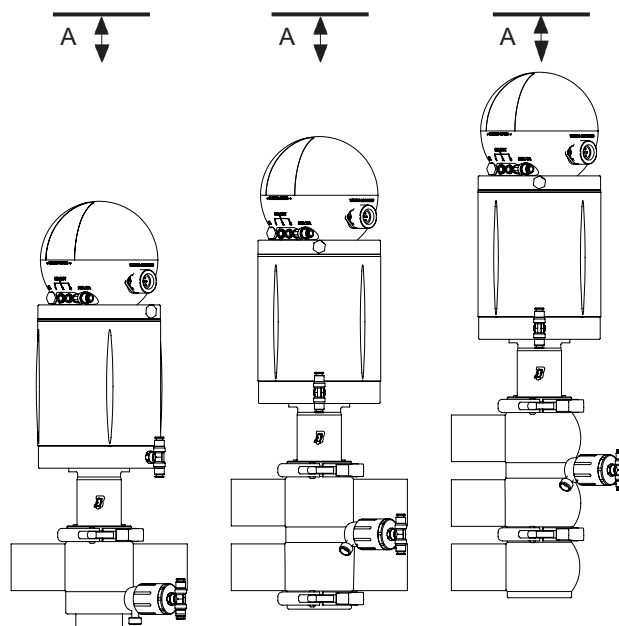

8. INSTALLING VALVE INTO PIPING:

Ensure sufficient clearance for valve disassembly.

5. Operation

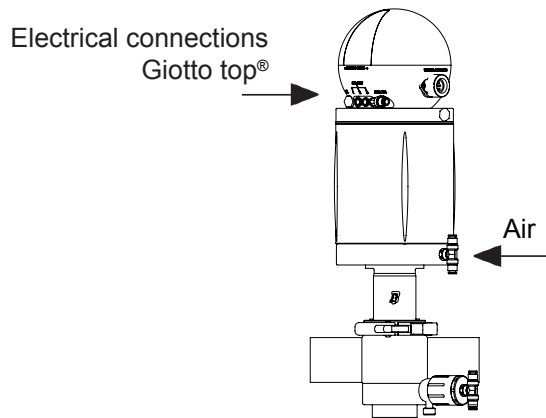

1. CONNECTION OF AIR AND EL SUPPLY

- Use authorised personnel to install/connect the valve.
- Ensure correct air pressure and quality (see page 25).
- Ensure correct electrical supply for Giotto Top® (see Giotto Top® instruction manual).

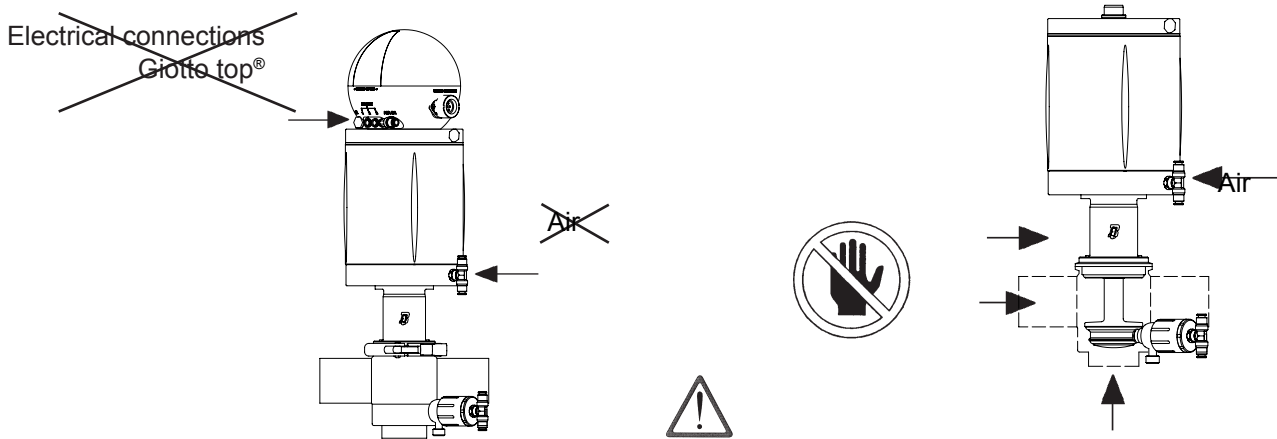

2. DISCONNECT SUPPLIES AFTER USE:

- Disconnect air supply.
- Disconnect electrical supply for Giotto Top®

3. MOVING VALVE PARTS:

- Never stick fingers into valve ports.
- Never touch moving valve shutter/stem.

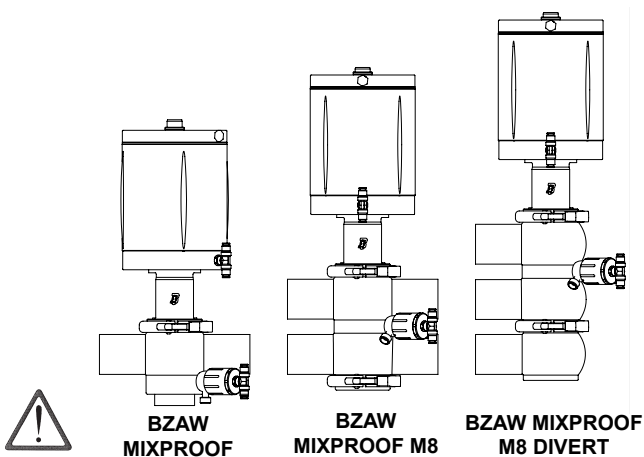

4. ONLY USE VALVE FOR DESIGNED PURPOSE:

BZAW: Pneumatic Mixproof

5. HOT VALVE/PIPING:

- Never touch hot valve or piping, if possible.
- Alternatively use protective gloves.

5. Operation



6. PRE-USE CHECK VALVE BEFORE OPERATION:

- Supply air to the valve.
- Supply el to the valve (with Giotto top®).
- Open and close the valve several times.
- Check that the valve functions operate correctly and smoothly.

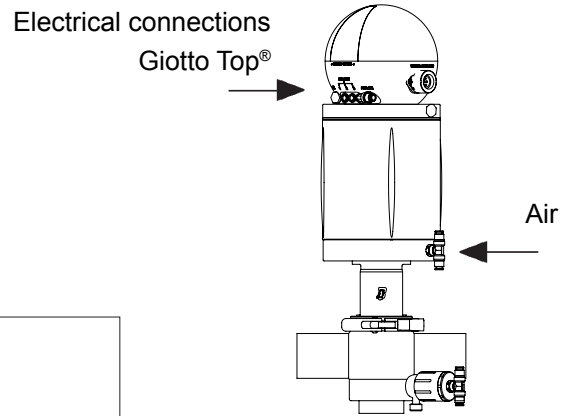

6. Troubleshooting



1. TROUBLESHOOTING VALVE:

Always study operation and maintenance instructions carefully before troubleshooting.



2. REPLACING WORN VALVE PARTS:

- See pge. 12 spare parts ordering.

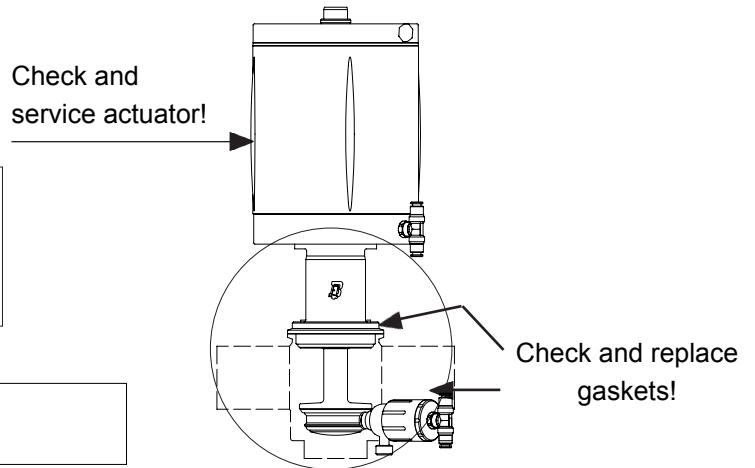

Problem	Possible cause	Possible remedy
External leakage		
Internal leakage with closed valve, caused by normal wear	Worn out gasket	Replace gasket
External leakage	Too high pressure	Replace with gasket of different elastomer type
	Too high temperature	
Internal leakage with closed valve occurring earlier than normal wear	Aggressive fluids	Modify operation conditions
	Too many active control	
Difficult opening and closing	Incorrect elastomer type of gaskets	Replace with gasket of different elastomer type
	Incorrect positioning of actuator	Assemble actuator correctly
	Incorrect operation of actuator	Change from normally open (NO) to normally closed (NC) or vice versa
	Dirt in actuator	Check and service actuator
	Incorrect positioning of valve body	Disassemble and reposition valve body

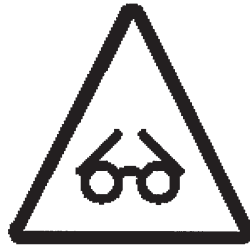

1. CLEANING VALVE WITH CLEANING AGENTS:

- Use authorised personnel to clean the valve.
- Observe concentrations of cleaning agents.
- Follow instructions of cleaning agent suppliers.
- Always use protective goggles and gloves.

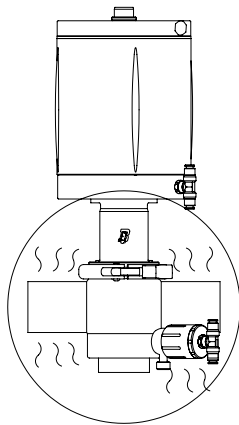

2. HOT VALVE/PIPING:

- Never touch hot valve or piping if possible.
- Alternatively use protective gloves.

Corrosion risk of stainless steel!

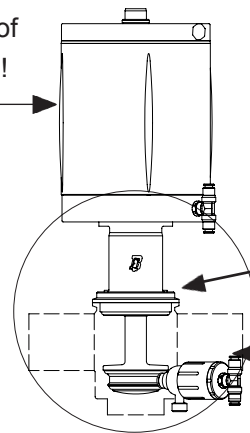

Damage risk of elastomers!!

3. HANDLING OF CLEANING AGENTS:

- Dose cleaning agents regularly to avoid excessive concentration.
- Always rinse carefully with clean water after cleaning.
- Check compatibility of valve materials.
- Always dispose of cleaning agents according to current directives

Example of suggested CIP		
Step	Temperature °C	Cip product
First rinsing	Atmosphere	Water without chlorine or chlorids
Washing	70°	Soda (NaOH) at 1%
Intermediate washing	Atmosphere	Water without chlorine or chlorids
Washing	70°	Nitric acid (HNO3) at 0,5%
Final rinsing	Atmosphere	Water without chlorine or chlorids

Recommended claning speed = 2 m/s

8. General Maintenance

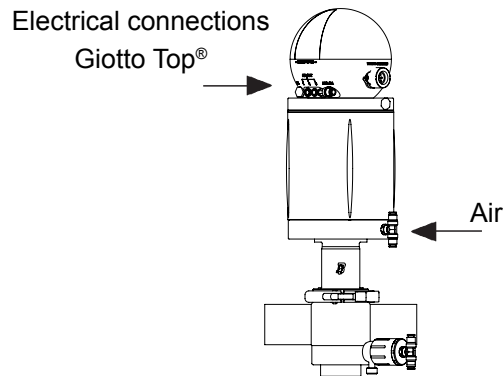

1. SUPPLYING AIR AND EL TO VALVE:

- Use authorised personnel to service the valve.
- Ensure correct air electrical supply for Giotto Top® (see Giotto Top® instruction manual).
- Ensure correct air pressure and quality (see page 25).
- Always dispose of cleaning agents according to current directives.

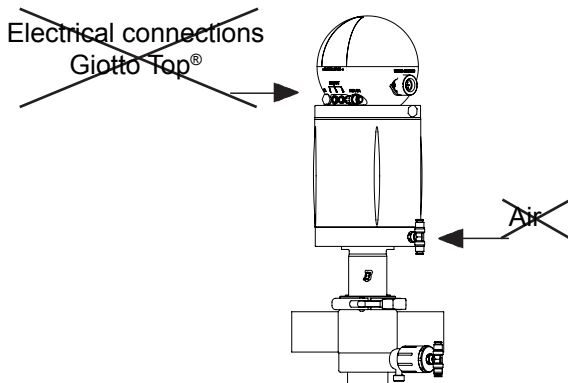

2. DISCONNECT SUPPLIES AFTER USE:

- Disconnect air supply.
- Disconnect electrical supply for Giotto Top®.

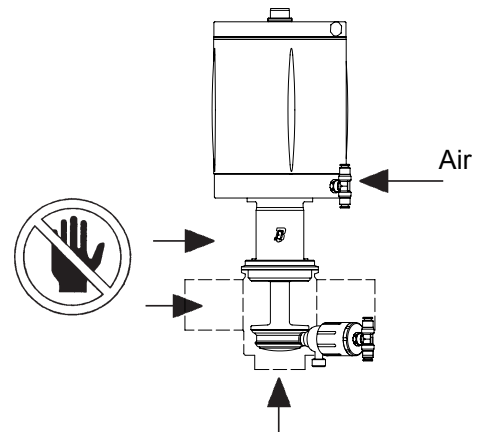

3. MOVING VALVE PARTS:

- Never stick fingers into valve ports.
- Never touch moving valve shutter/stem.

Atmospheric pressure required!

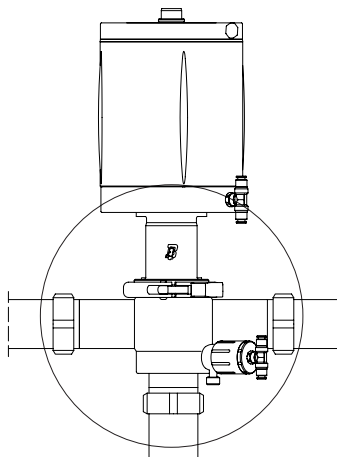

4. PRESSURISED VALVE/PIPING:

Always release fluid pressure from valve and piping before disassembling the valve.



BURNING RISK!!

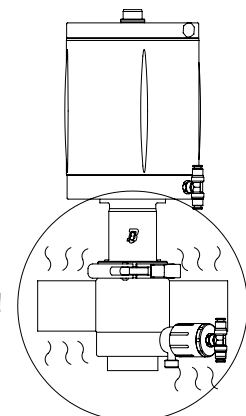

5. HOT VALVE/PIPING:

- Never touch hot valve or piping, if possible.
- Alternatively use protective gloves.

8. General Maintenance

Wash and clean
thoroughly

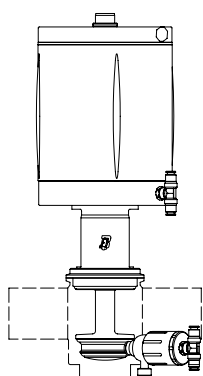

6. CLEANING OF DEPOSITS:

- Wash and clean all valve parts thoroughly before disassembly and assembly!
- Pay attention to possible deposits of cleaning agents and other aggressive fluids!
- Always use protective goggles and gloves, if necessary.



7. REPLACING WORN VALVE PARTS:

- Always use original spare parts.
- See page 12 for spare parts ordering.
- Dispose of worn parts according to current directives.

9. Planned Maintenance

Planned maintenance	Valve gaskets	Actuator gaskets
Preventive	Replace after 12 months	Replace after 24 months
In case of leakage	Replace at the end of the day	Replace in case of leakage
Periodical	Check for correct operation and absence of leakage	Check for correct operation and absence of leakage
	Record all actions taken	Record all actions taken

10. Spare Parts Ordering



NOTE!

Please copy this page, fill it out and fax it to below address.

À:
BARDIANI VALVOLES S.P.A. – Ufficio Ricambi
Fax: +3905253408

From:

Valve type:

Valve type:

Month/Year of purchase:

Shipping instructions:

Quantity:		Position no.:	
Description:			

Quantity:		Position no.:	
Description:			

Quantity:		Position no.:	
Description:			

Quantity:		Position no.:	
Description:			

11. Disassembly of BZAW

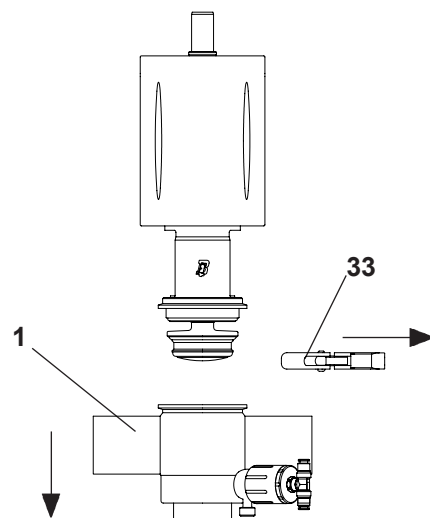
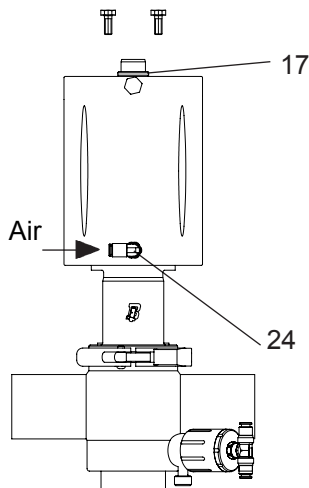

- 1. Fix the guide bushing (17) through 2 screw M6x10 and supply air to fitting (24).
- 2. Remove clamp (33) and body (1)

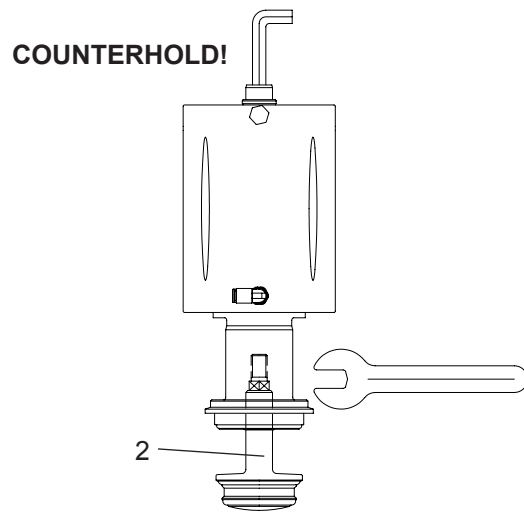
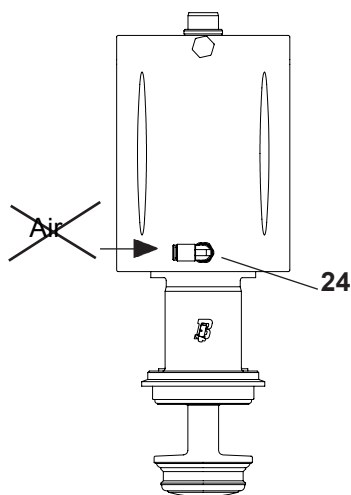

- 3. Release air pressure to air fitting (24).
- 4. Unscrew shutter (2). Counterhold the pivot with an Allen wrench.

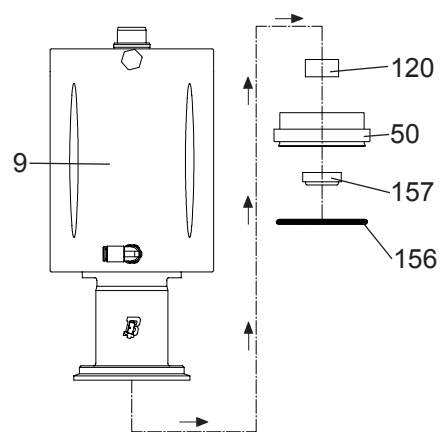
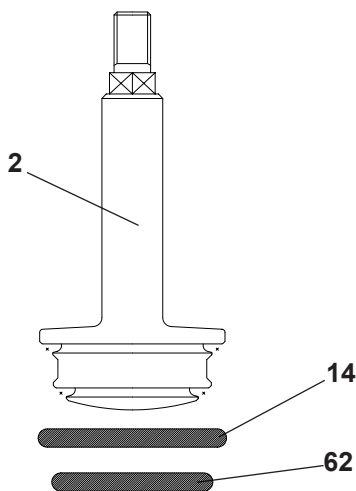

- 5. Remove shutter ring (14,62).
- 6. Remove from the cylinder (9) the cap (50). Remove, from the same, gaskets (156 e 157) and the guide bushing (120).

11. Disassembly of BZAW

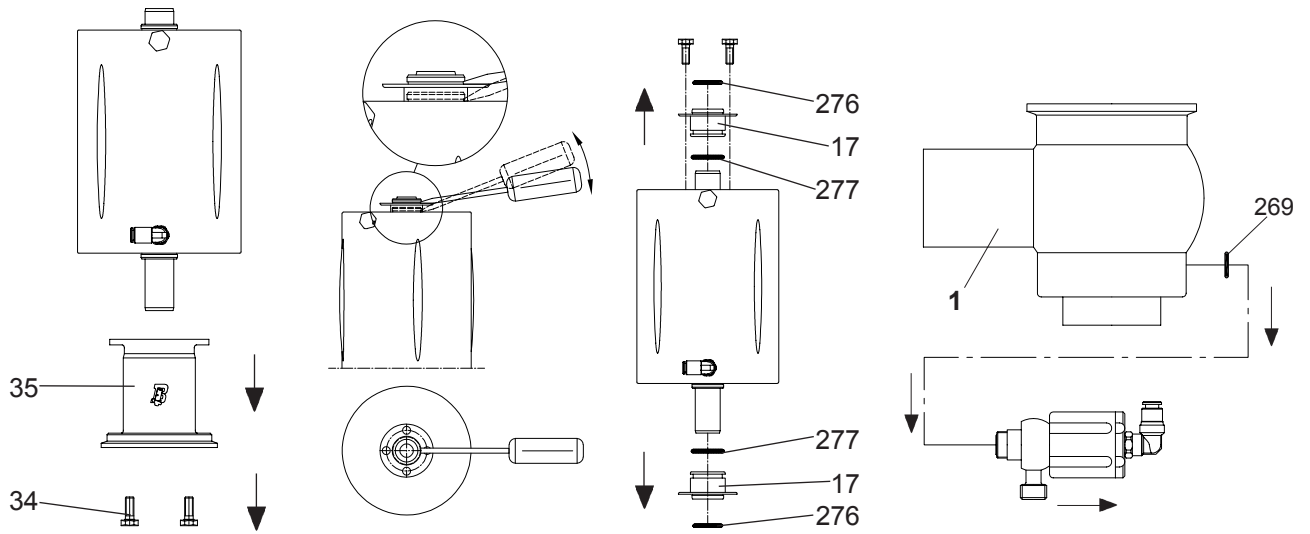

7. Remove screws (34) and assembly (35).

8. Remove screws M6x10 and guide bushing from the cylinder (17) with a suitable tool. Remove seal rings (277 e 276).

9. Unscrew little valve from the body (1) and remove sealing ring (269).

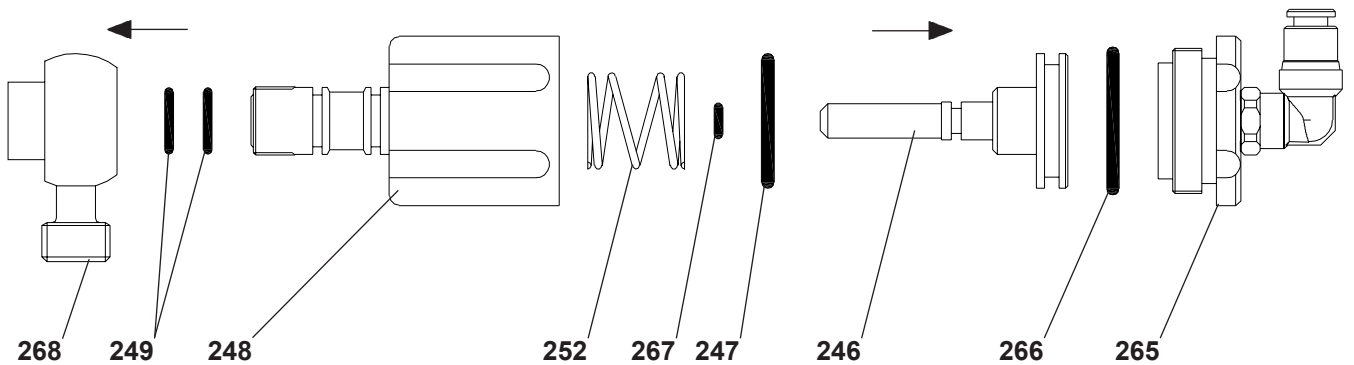

10. Remove the valve body (268) from the cylinder (248) and remove sealing rings (249). Unscrew the plug (265) from the cylinder (248), Slide out the piston (246) and the spring (252). Remove sealing rings (267,247,266).

11. Disassembly of BZAW

BZAW

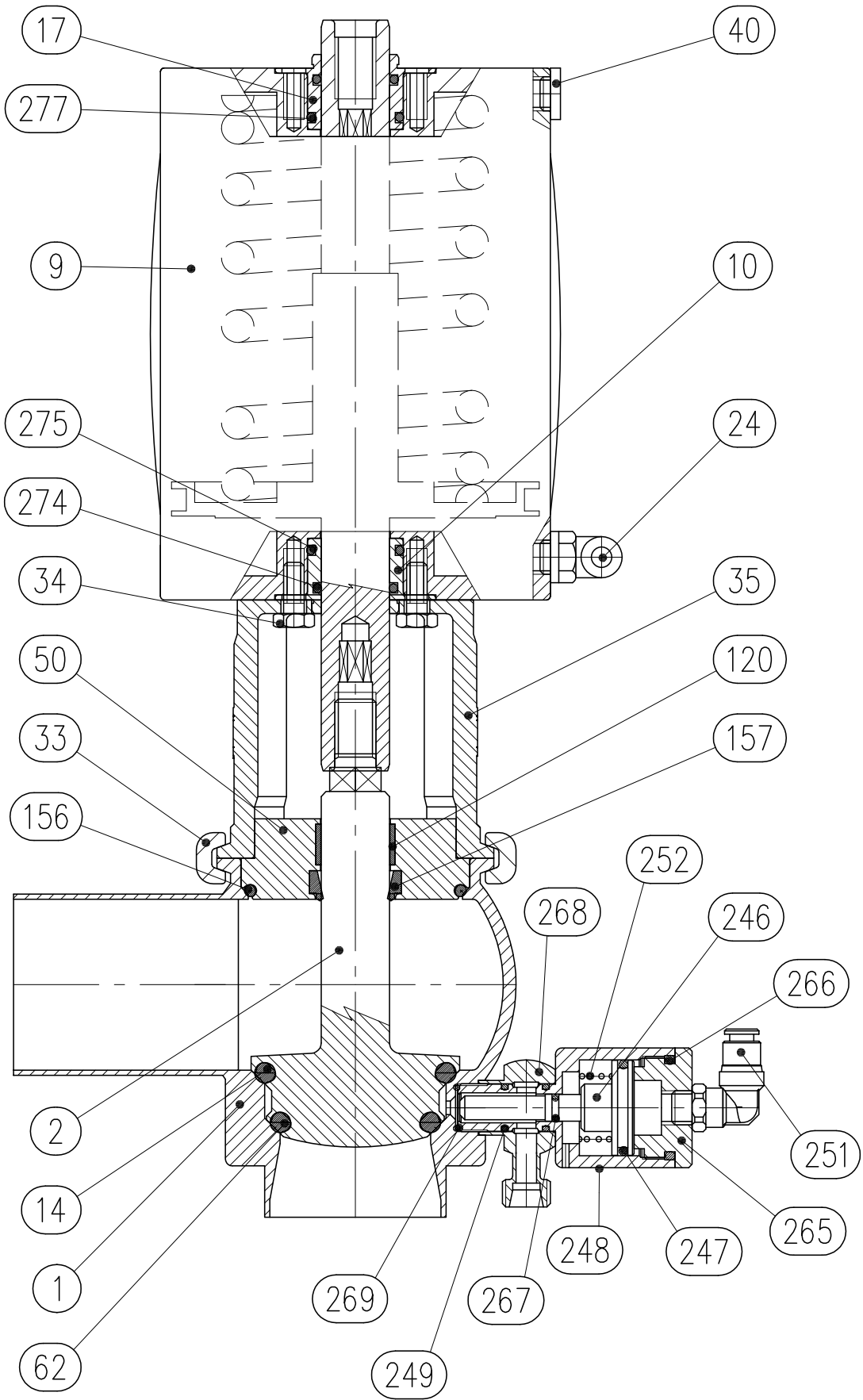

12. Assembly of BZAW

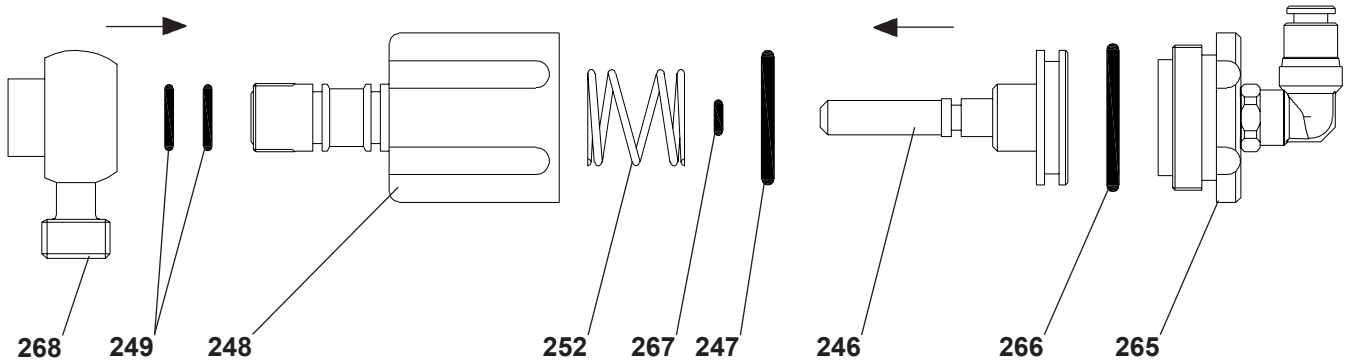

1. Put sealing rings (249)* into the cylinder (248) and assemble the body (268). Insert sealing rings (247, 267*) in to the piston (246). Assemble the sealing ring (266) into the plug (265). Put the spring (252) and the piston (246) in to the cylinder (248). Screw the plug (265) on the cylinder (248).

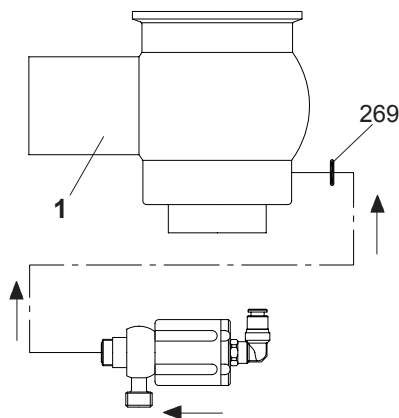

2. Insert the sealing ring (269)* in the body (1) then screw the little valve in to it.

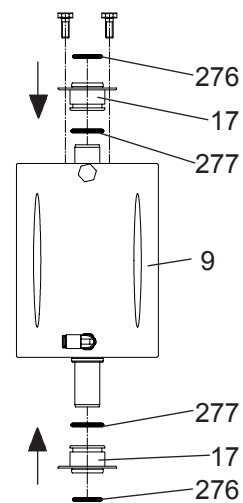

3. Insert seal rings (276 e 277) on the guide bushing (17) and assembly them on the cylinder (9). Fix upper guide bushing with two screw M6x10.

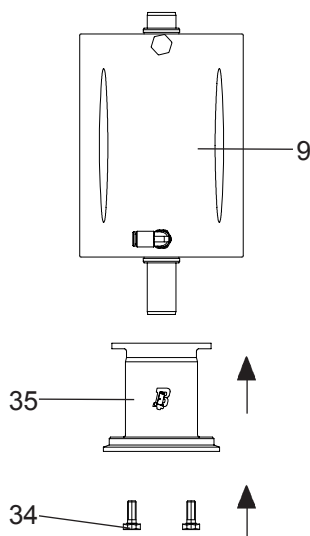

4. Fit assembly (35) to cylinder (9) with screws (34).

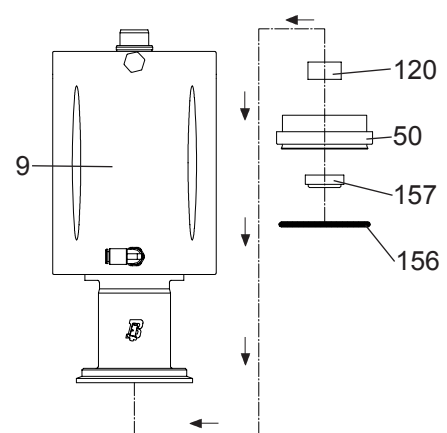

5. Insert seal rings (156 and 157)* and guide bushing (120)* into the cap (50). Fit the cap on the cylinder (9).



12. Assembly of BZAW

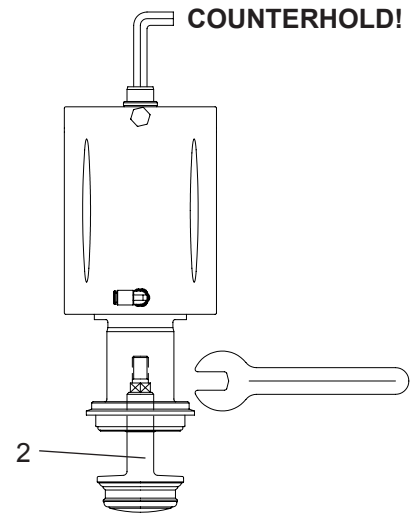
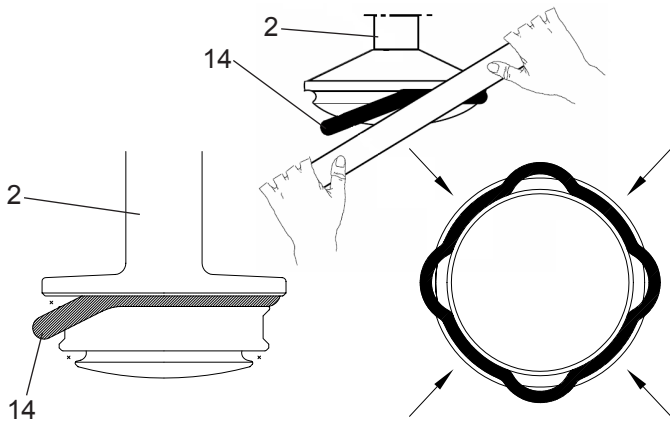

6. Pre-heat shutter ring (14*) to approx. 80°C to make it softer and insert it in shutter slot (2). Insert the ring in a crosswise manner using a plastic cylindrical tool.

7. Screw shutter (2) into cylinder pivot (9). Counterhold the pivot with an allen wrench.

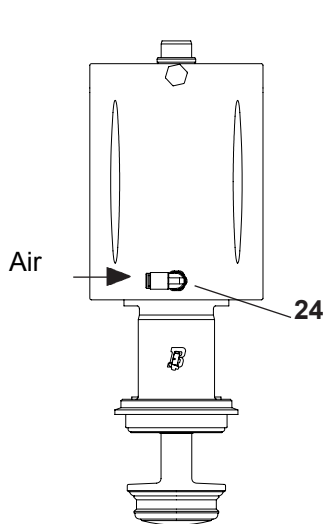

8. Supply air to fitting (24).

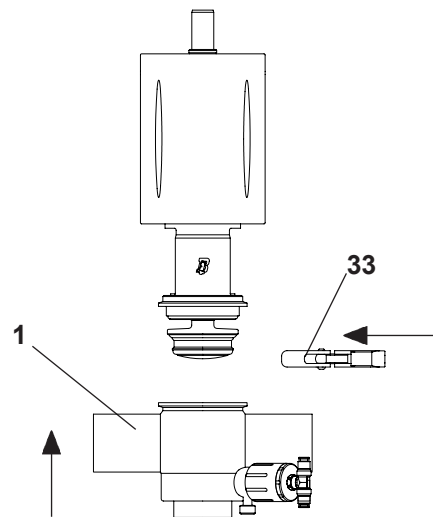

9. Assemble body (1) and assembly (35) with clamp (33).

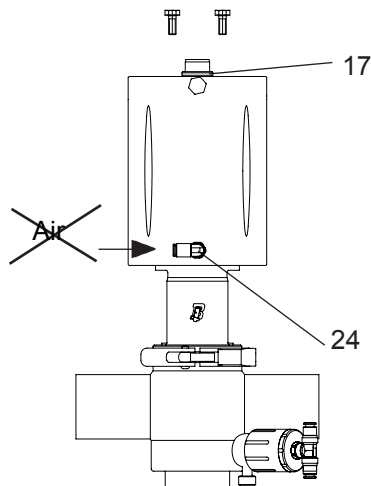

10. Release air pressure to air fitting (24) and remove 2 M6x10 to allow assembly of the Giotto-Top®.



13. Disassembly of BZAW divert

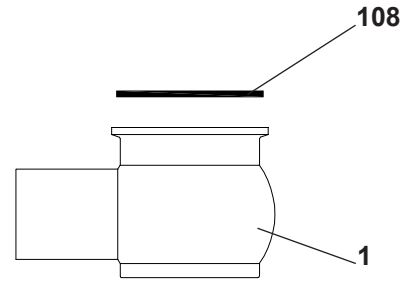
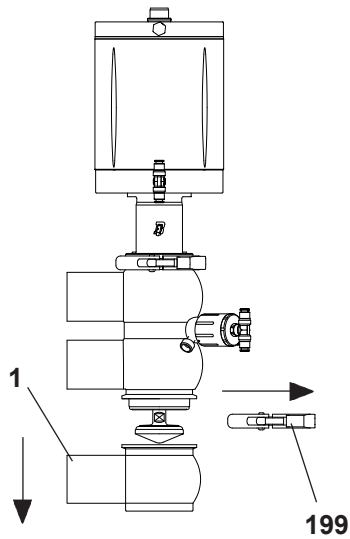

1. Remove clamp (199) and body (1)

2. Remove seal ring (108) from body (1).

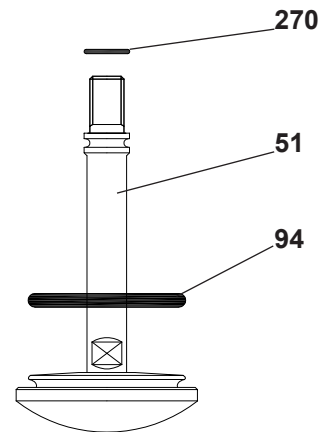
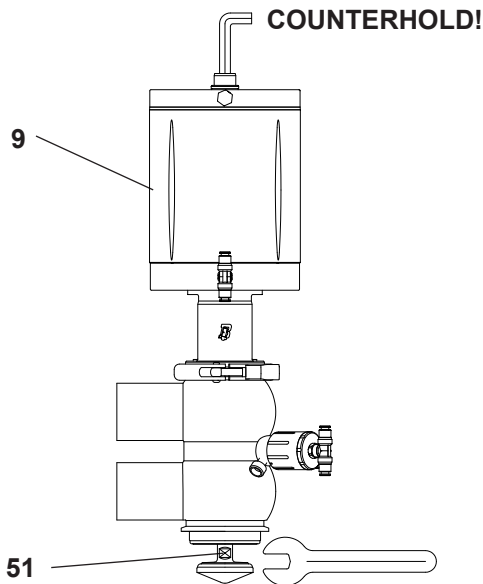

3. Unscrew lower shutter (51) from cylinder pivot (9). Counterhold the pivot with an Allen wrench.

4. Remove shutter ring (94,270).

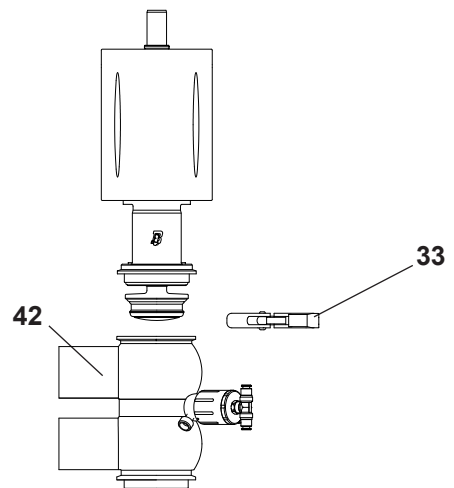
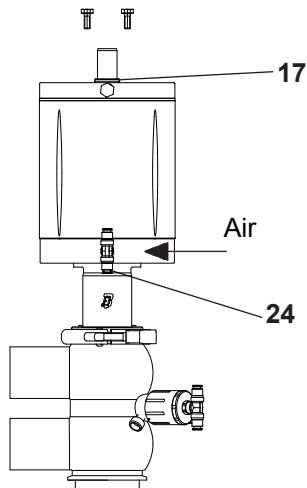

5. To fix the washer (7) through 2 screw M6x10 and supply air to fitting (24).

6. Remove clamp (33) and double body (42).

13. Disassembly of BZAW divert

COUNTERHOLD!

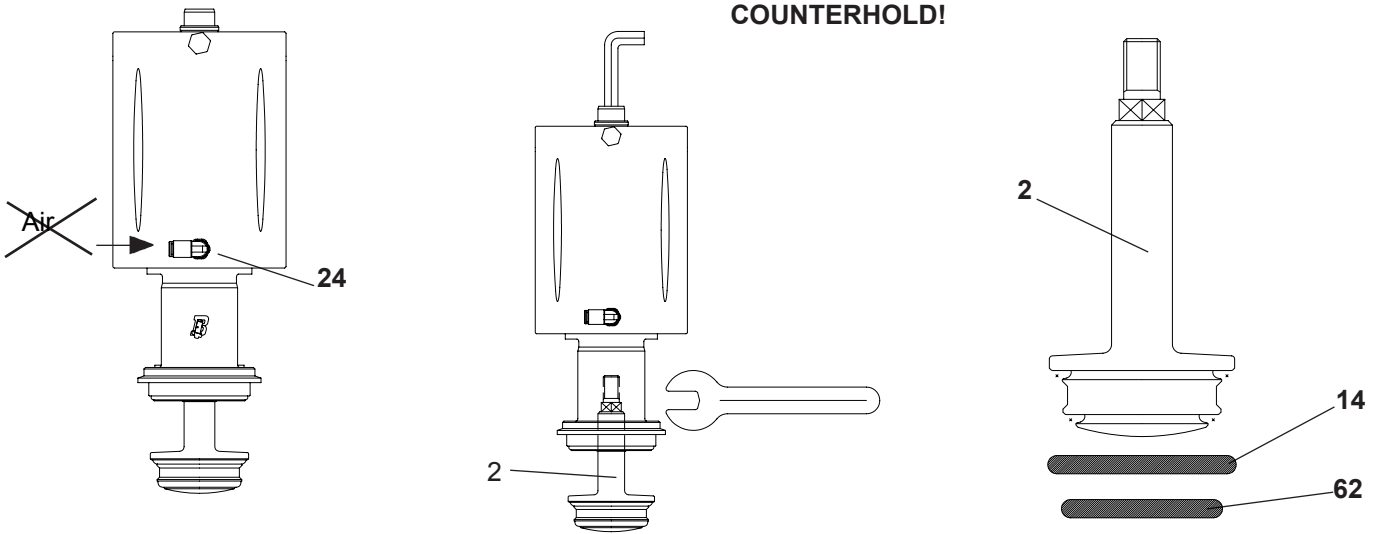

7. Release air pressure to air fitting (24).

8. Unscrew shutter (2) from cylinder pivot (9). Counterhold the pivot with an Allen wrench.

9. Remove shutter sealing rings (14,62).

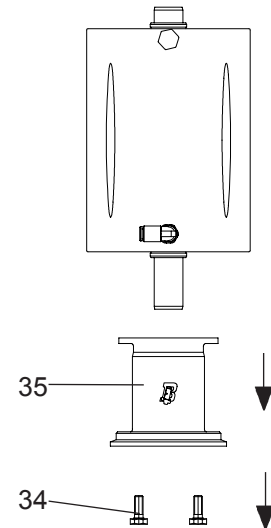
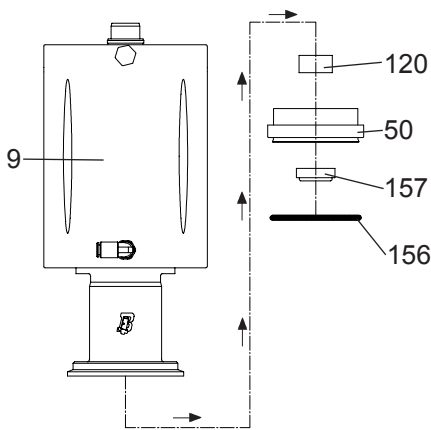

10. Remove from the cylinder (9) the cap (50). Remove, from the same, gaskets (156 e 157) and the guide bushing (120).

11. Remove screws (34) and assembly (35).

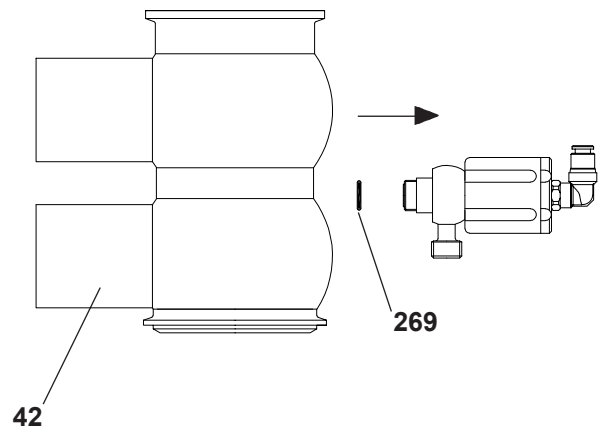
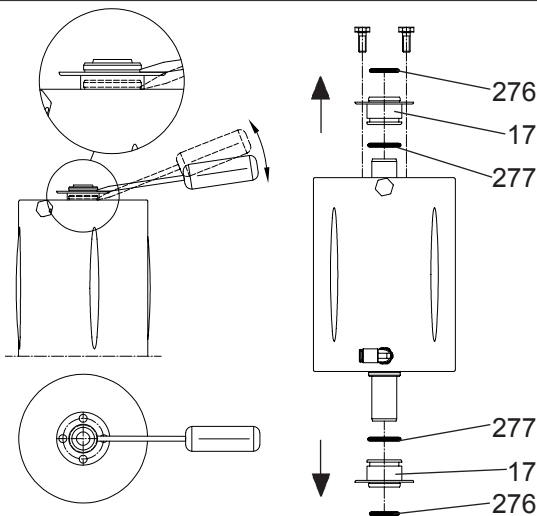

12. Remove screws M6x10 and guide bushing from the cylinder (17) with a suitable tool. Remove seal rings (277 e 276).

13. Unscrew little valve from the double body (42) and remove sealing ring (269).

13. Disassembly of BZAW divert

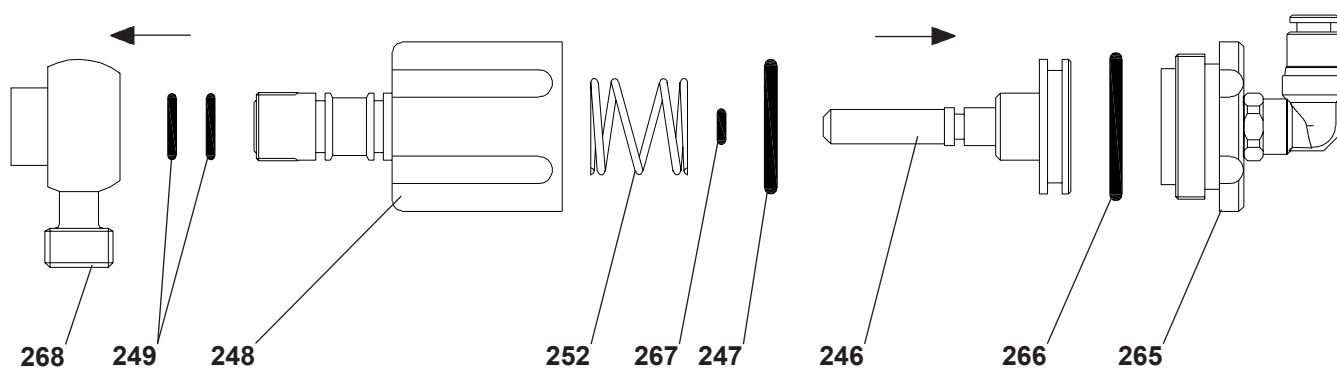

14. Remove the valve body (268) from the cylinder (248) and remove sealing rings (249). Unscrew the plug (265) from the cylinder (248), Slide out the piston (246) and the spring (252). Remove sealing rings (267,247,266).

13. Disassembly of BZAW divert

BZAW DIVERT

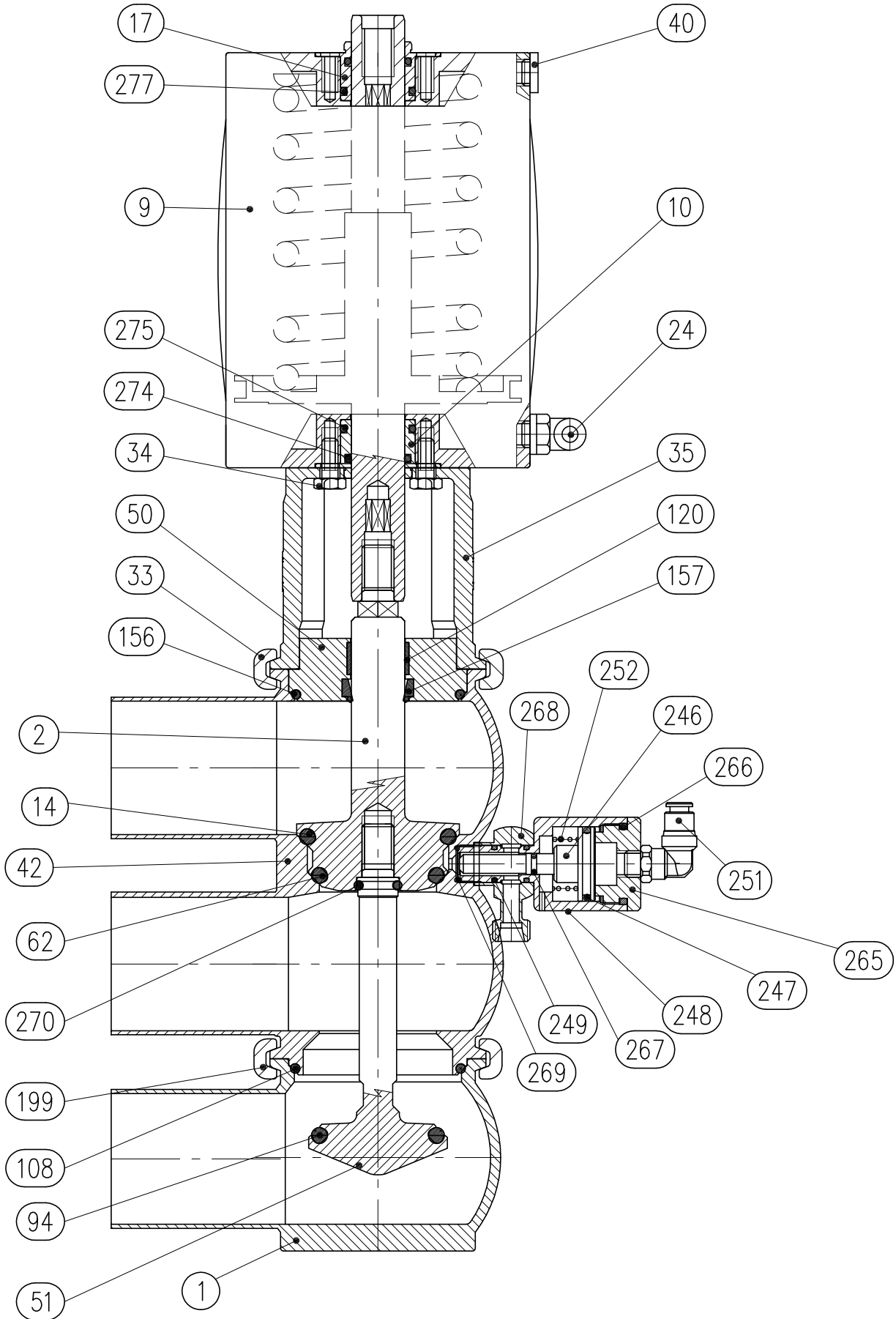

14. Assembly of BZAW divert

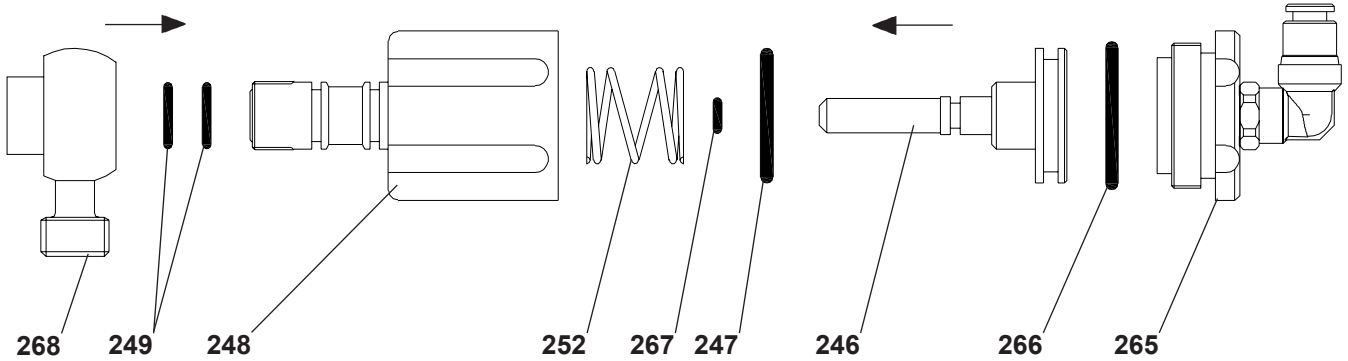

1. Put sealing rings (249)* into the cylinder (248) and assemble the body (268). Insert sealing rings (247, 267*) in to the piston (246). Assemble the sealing ring (266) into the plug (265) Put the spring (252) and the piston (246) in to the cylinder (248). Screw the plug (265) on the cylinder (248).

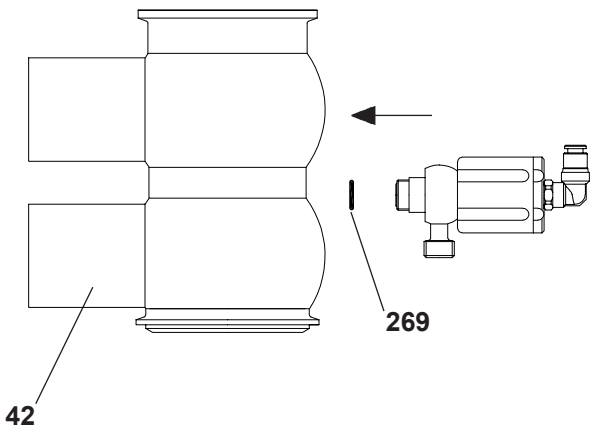

2. Insert the sealing ring (269)* in the double body (42) then screw the little val in to it.

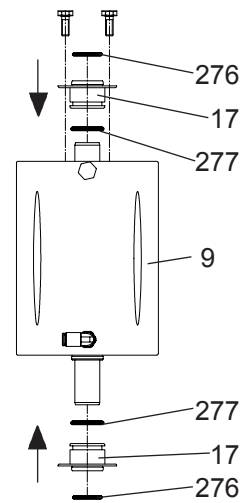

3. Insert seal rings (276 e 277) on the guide bushing (17) and assembly them on the cylinder (9) Fix upper guide bushing with two screw M6x10.

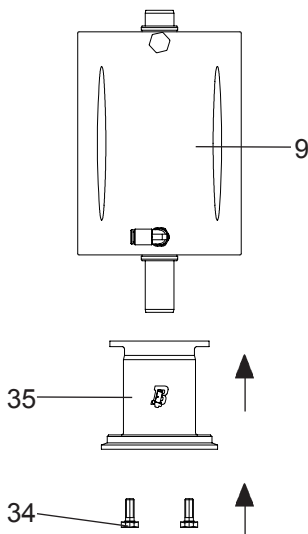

4. Fit assembly (35) to cylinder (9) with screws (34).

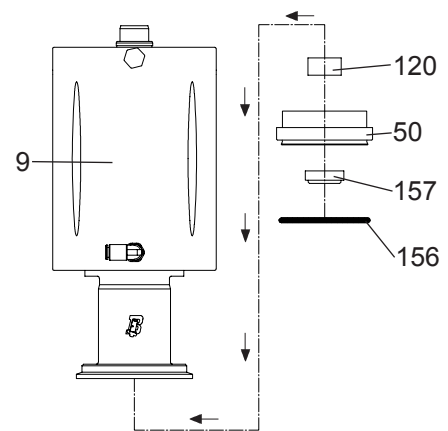

5. Insert seal rings (156 and 157)* and guide bushing (120)* into the cap (50). Fit the cap on the cylinder (9).

14. Assembly of BZAW divert

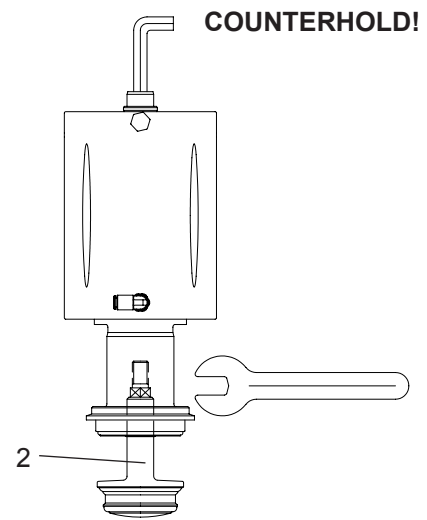
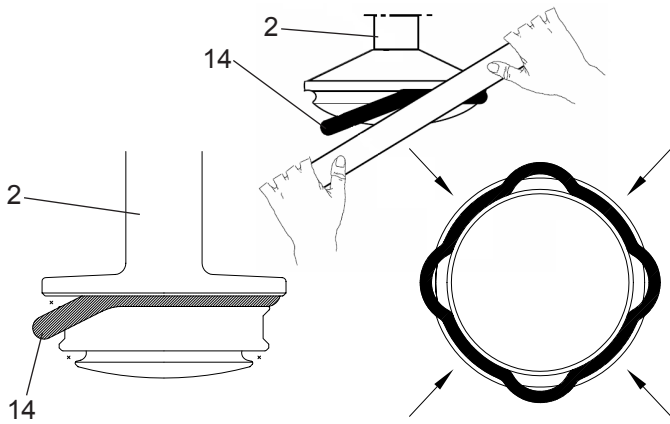

6. Pre-heat shutter ring (14*) to approx. 80°C to make it softer and insert it in shutter slot (2). Insert the ring in a crosswise manner using a plastic cylindrical tool.

7. Screw shutter (2) into cylinder pivot (9). Counterhold the pivot with an allen wrench.

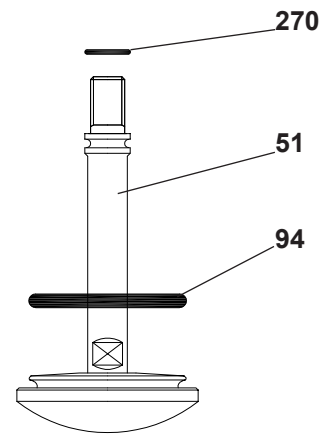
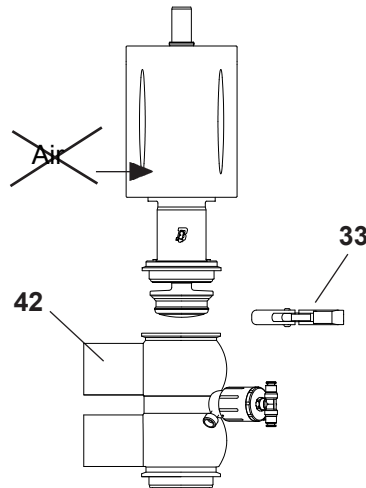
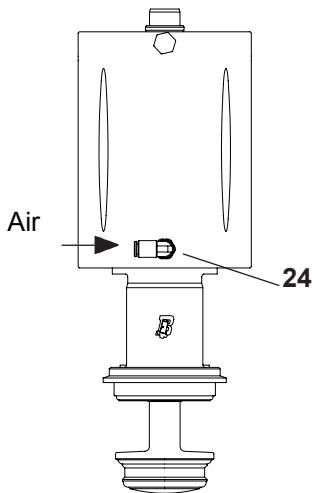

8. Supply air to fitting (24).

9. Assemble body (42) with clamp (33). Release air pressure to air fitting (24).

10. Insert the sealing ring (270,90)* in to the shutter (51).

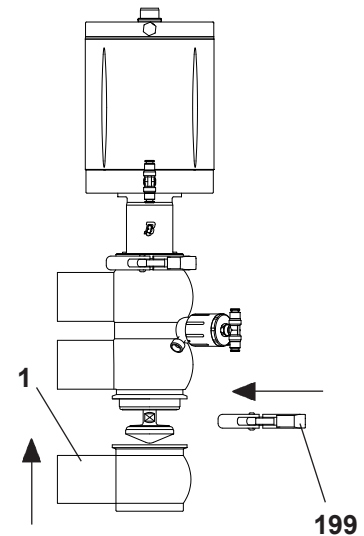
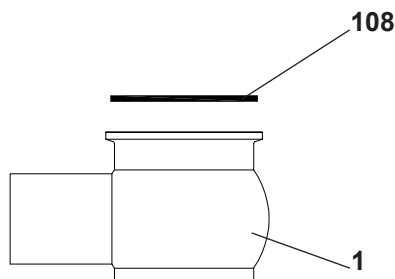
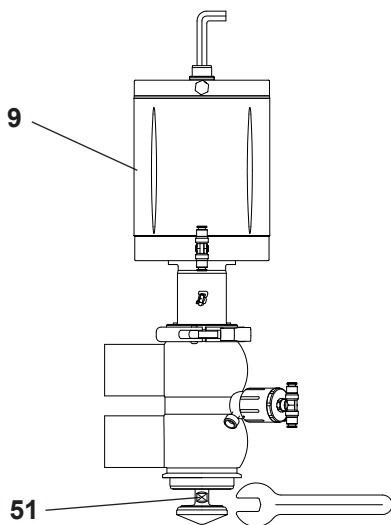

11. Insert the shutter (51) and screw it in the cylinder (9) counterhold with an allen wrench.

12. Insert the saling ring (108)* in the body (1).

13. Assemble the body (1) with clamp (199).



15. Part List

N°	Description	N°	Description
1	Lower body	267	Seal ring
2	Shutter	268	Body
4	Seal ring	269	Seal ring
6	Seal ring	270	Seal ring
9	Cylinder		
10	Guide bushing		
11	Pivot		
14	Seal ring		
16	Seal ring		
24	Air fitting		
33	Clamp		
34	Socket screw		
35	Assembly		
40	Plug		
42	Double body		
50	Sealing ring disc		
51	Lower shutter		
62	Seal ring		
94	Seal ring		
108	Seal ring		
199	Clamp		
246	Seal ring		
247	Seal ring		
248	Cylinder		
249	Seal ring		
251	Air fitting		
252	Spring		
265	Plug		
266	Seal ring		

16. Technical Data

Valve Specifications:

Max. working pressure:	10 bar (145 psi)
Min. working pressure:	Full vacuum
Max. product temperature:	140° C (284° F)
Min. product temperature:	-10° C (14°F)
Material in contact with the product:	AISI 316L (1.4404)
Gasket in contact with the product (FDA homologation):	EPDM, FKM, MVQ(silicon), HNBR, PTFE (other seals available upon request).
Finish on surfaces in contact with the product:	Ra 0.8 µm (other types of surface finish upon request).

Pneumatic Actuator Specifications:

Connectors:	1/8" (BSP)
Air Pressure:	from 6 bar (87 psi) to 8 bar (116 psi)
Material:	AISI 304L (1.4307)
Gasket Material:	NBR
Power Supply (Giotto Top®) :	See Giotto Top® Instruction manual

PED Directive 97/23/EEC, with special reference to Annex III, Module A regarding internal production control as Conformity Assessment Procedure in force

(valve sizes DN15--25 are not included in accordance with Article 3 paragraph 1.3:

Valves intended for gases, liquified gases, gases dissolved under pressure, vapours and those liquids whose vapour pressure at the maximum allowable temperature is greater than 0,5 bar above normal atmospheric pressure (1013 mbar) within the following limits:

For fluids in Group 1 with a DN greater than 25

Valve size DN125 only for fluids in Group 2)

Foreword

This "Instruction, Use and Maintenance Manual" forms an integral part of the valve.

Before proceeding with installation, use or maintenance of each type of valve it is compulsory to read and understand this manual.

Keep this manual for future reference.

When using valves which comply with ATEX Directive 94/9/EC (ATEX) it is compulsory to read the relative manual.

This "Instruction, Use and Maintenance Manual" has been drawn up expressly for expert technical personnel. Consequently any information which can easily be deduced from reading the text and/or examining the illustrations and/or drawings provided herein shall not be the object of further explanation.

It being understood that the essential characteristics of the valve type described herein shall remain the same, the manufacturer reserves the right to amend and/or integrate and/or update the data and/or information relative to use of the valve provided in the "Instruction, Use and Maintenance Manual", at any time and without prior notice.

The latest, updated version of the "Instruction, Use and Maintenance Manual" is always available at www.bardiani.com.

The manufacturer shall not in any way be held liable for any consequences resulting from failure to observe all the prescriptions provided in the relative manual concerning installation, use, maintenance and care of the product.

All rights are reserved. It is forbidden, without due written authorization from the manufacturer, to copy totally and/or partially and /or transfer and/or record any part of this "Instruction, Use and Maintenance Manual" using any means and/or support, including IT and/or electronic and/or mechanical and/or paper form or any other means or system for recording and/or reusing the information contained herein for any purposes other than for the purchaser's personal use.

Warranty

1. VALIDITY

Bardiani Valvole S.p.A. guarantees its own products against any design and/or construction and/or material defects and/or faults for a period of 12 (twelve) months from the date of delivery.

Notification of any product defects and/or faults must be sent in writing to Bardiani Valvole S.p.A. within 8 (eight) days of coming to light, providing adequate documentation of the defect/fault encountered can be provided as evidence.

Any repairs made during the warranty period do not extend said period over the stipulated 12 (twelve) months which remains definite.

2. CONTENTS OF THE WARRANTY

This warranty it to be intended as limited, at the discretion of Bardiani Valvole S.p.A., to the repair and/or replacement of the product and/or part of the product and/or its components which is/are found to be defective due to design and/or manufacturing and/or material faults.

In the event of repair and/or replacement of the product and/or any one of its parts and/or components, any returned item/s shall become the property of Bardiani Valvole S.p.A and the relative shipping costs shall be at the expense of Bardiani Valvole S.p.A.

Bardiani Valvole S.p.A., shall be under no obligation to compensate for any immaterial and/or indirect damages and shall in no way be held liable for consequential damages and/or losses, such as (by way of example only), damages due to loss of business, contracts, opportunities, time, production, profits, goodwill, image etc..

No retailer or distributor or dealer or agent or representative or employee or person appointed by Bardiani Valvole S.p.A. is authorized to make any amendments and/or integrations and/or extensions to this warranty.

3. EXCLUSIONS FROM THE WARRANTY

All purchaser rights, as established and recognized by law being understood and unaffected, elastomers and electrical components are expressly excluded from this warranty.

This warranty does not cover design faults whenever a product is built by Bardiani Valvole S.p.A. based on designs and/or technical specifications provided by the purchaser.

This warranty also does not cover:

- faults and/or defects resulting from incorrect and/or unsuitable and/or improper transport,
- faults and/or defects resulting from installation of the product which fails to observe the indications provided in the "Instruction, Use and Maintenance Manual" or in any case caused by incorrect and/or unsuitable and/or improper installation,
- faults and/or defects resulting from use and/or maintenance operations and/or storage of the products which fail to observe the prescriptions provided in the "Instruction, Use and Maintenance Manual" or in any case which are incorrect and/or unsuitable and/or improper,
- faults and/or defects ascribable to normal wear and tear of the product and/or its parts and/or its components,
- faults and/or defects in the product and/or its parts and/or its components whenever interventions and/or repairs have been performed by persons not authorized by Bardiani Valvole S.p.A. and/or who are not suitably qualified,
- faults and/or defects in the product and/or its parts and/or its components ascribable to it being dropped and/or banged and/or dented and/or misuse and/or tampering and/or breakage and/or accidents caused by negligence and/or lack of care by the purchaser and in general for any causes not ascribable to design and/or manufacturing and/or material defects,
- faults and/or defects in the product and/or its parts and/or its components ascribable to negligence and/or carelessness and/or lack of care by the purchaser,
- faults and/or defects in the product and/or its parts and/or its components caused by other events outside the control of Bardiani Valvole S.p.A. or determined by force majeure **or mishap**.

Recommendations

1. All the information, indications, statements and technical details provided herein are based on test data which Bardiani Valvole S.p.A. holds to be reliable but which cannot be expected to cover every possible use of the product.

2. The illustrations and drawings provided are all indicative and are not binding, consequently they may not fully match the real appearance of the products.

3. Being as the conditions of product use and applications cannot be controlled by Bardiani Valvole S.p.A., the purchaser must ascertain suitability of the use he intends to make of the product beforehand and assume all risks and liabilities which may result from the same.

4. Customers are strongly advised to consult Bardiani Valvole S.p.A.'s technical-commercial collaborators to request any specific information concerning the technical characteristics of the products.

5. The information provided in this document refers to standard production Bardiani Valvole S.p.A. products and therefore cannot be considered a basic reference for products built to meet specific requirements.