

BRECOflex CO., L.L.C.

High Precision Drive Components

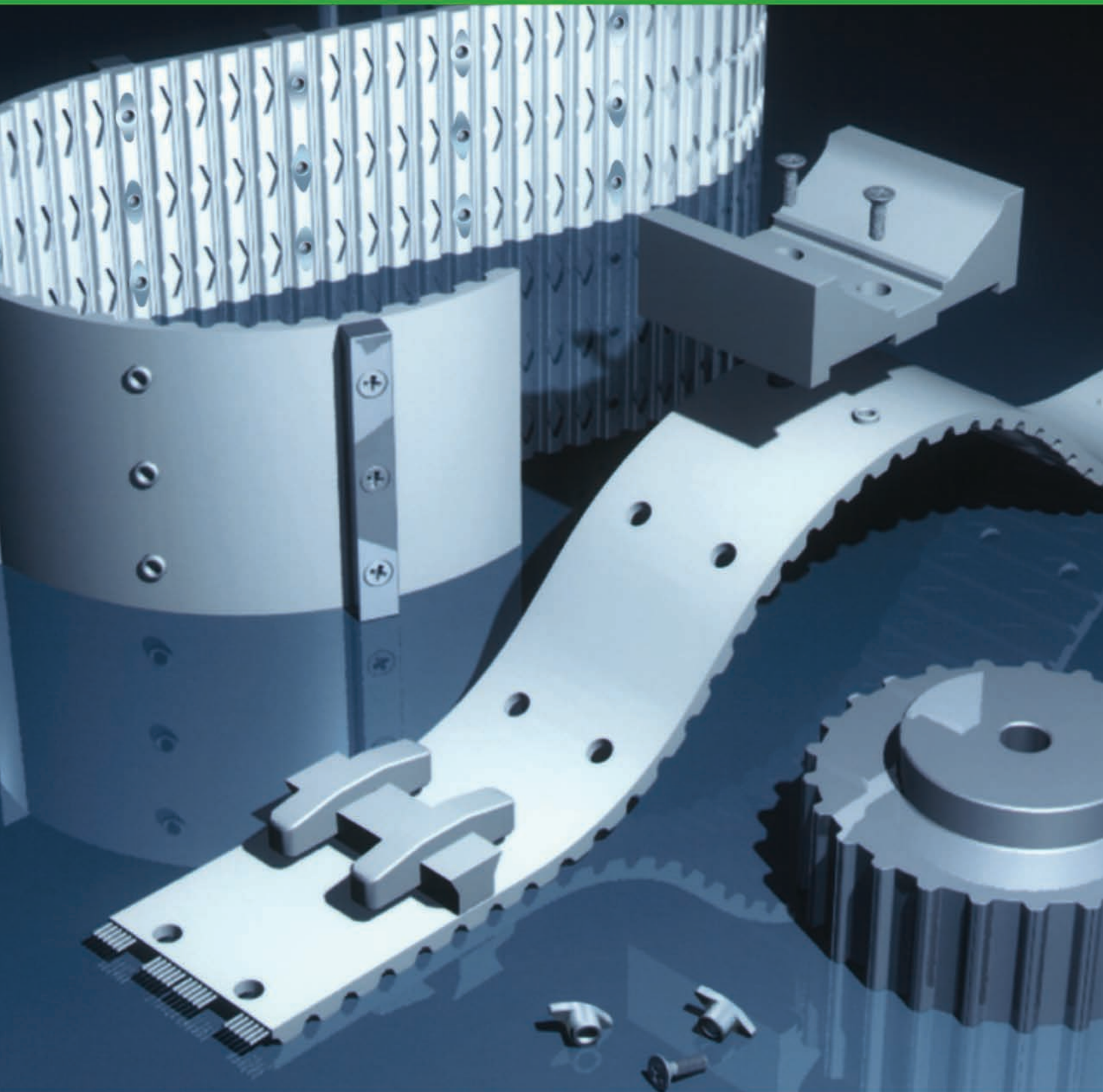

ATN[®] - CONVERTIBLE TIMING BELT SYSTEM

ATN - CONVERTIBLE TIMING BELT SYSTEM

ATN® - THE SOLUTION FOR VARIABLE CONVEYOR SYSTEMS

BRECOflex CO., L.L.C., the world leader in the polyurethane timing belt industry, is setting new standards by offering new state-of-the-art drive components. BRECOflex CO., L.L.C. proudly offers the ATN convertible profile system.

This new technology provides for rapid and easy configuration of profiles with simple hand tools. By changing the profile location, different size goods, for instance, can be handled with the same base timing belt. A multitude of profiles can be attached, converted, interchanged, or reconfigured on the same base timing belt, either in-house or in the field at the customer site. ATN technology combines flexibility, strength, and accuracy and offers high precision profile positioning. The profiles are fastened to the timing belt by means of polyamide or brass inserts. Mounting holes (cavities) for the inserts are extruded into every tooth of the base timing belt, which guarantees accurate profile placement.

BRECOflex CO., L.L.C. designs and offers convertible profiles to suit the customer's specific applications. Users can create and assemble their own profiles for their specific needs.

It is the intention of BRECOflex CO., L.L.C. to provide customers with outstanding products and technical support to meet their expectations. BRECOflex CO., L.L.C. has developed many patented processes for producing a wide array of sophisticated, high precision timing belts. Worldwide, more OEMs specify BRECOflex CO., L.L.C. timing belts and drive components than any other brand.

ATN® ADVANTAGES

- The timing belt is part of a modular system
- Variable profile pitch
- Different profile materials can be utilized
- No belt disassembly is necessary to change profiles
- Alternative to chain with the advantages of a timing belt
- Standard timing belt pulleys can be used*
- High shear strength
- Quick and easy profile change
- Profile spacing is extremely precise
- Self-positioning of profiles
- Master profiles accept customer attachments
- No profile welding beads
- Standard AT tooth profiles
- Service friendly
- Reduced downtime

* For ATN 12.7, see chart on page 4, ATN Tooth Pitches and Tooth Profiles.

ATN - CONVERTIBLE TIMING BELT SYSTEM

ATN® SYSTEM

ATN timing belts are available as open ended or welded endless belts. These timing belts are constructed of abrasion resistant polyurethane (Standard: 92 Shore A) and high strength steel or stainless steel tension members. Food grade, high ambient temperature, and cold - flexible polyurethane materials are available in all base belt versions. ATN timing belts are universally suitable for various positioning and conveying applications.

CHARACTERISTICS

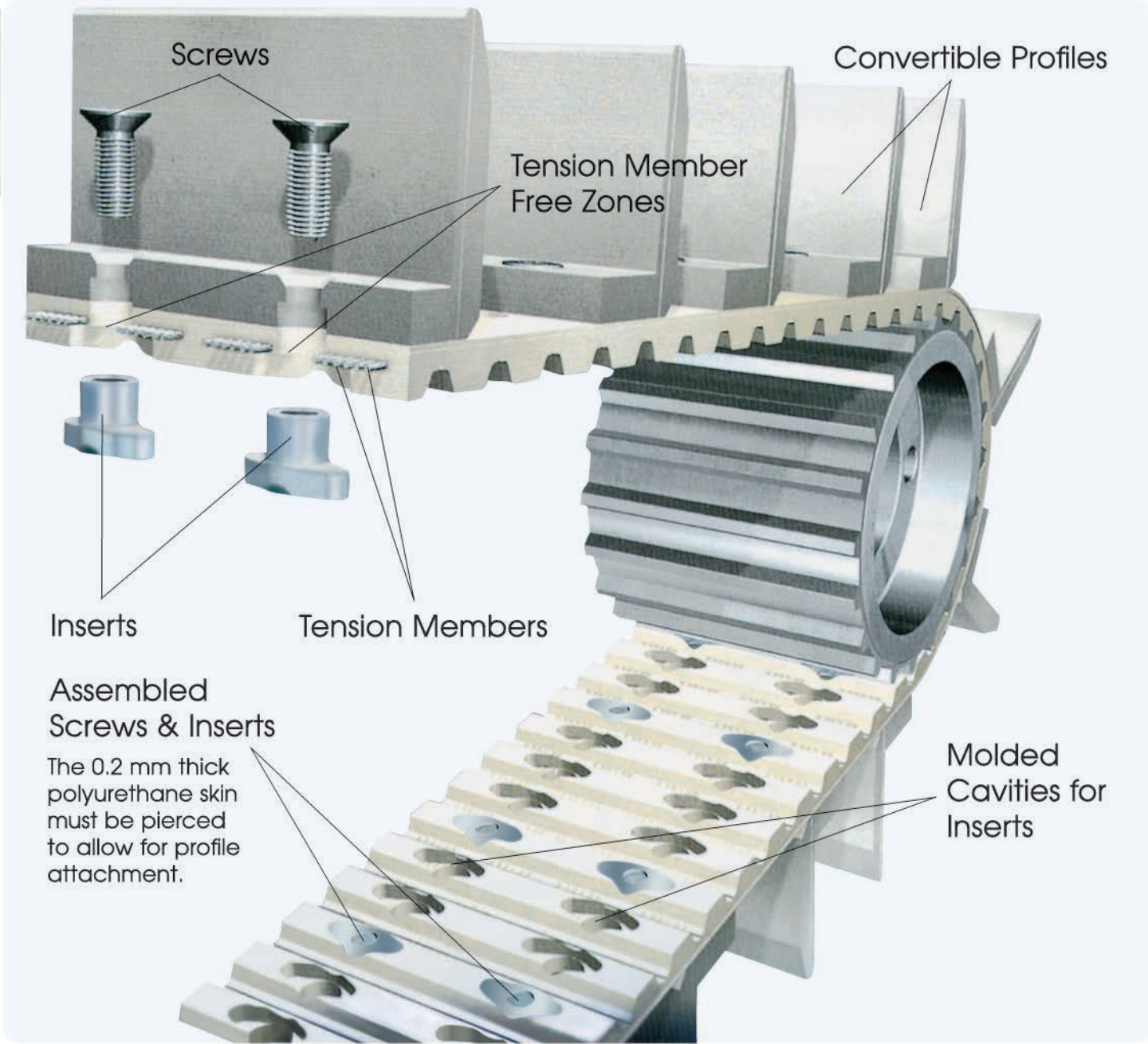

ATN - CONVERTIBLE TIMING BELT SYSTEM

PRODUCT RANGE

ATN Tooth Pitches and Tooth Profiles

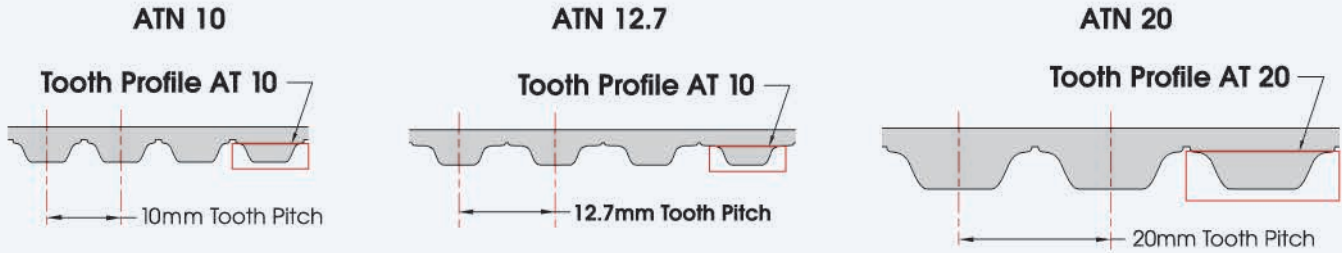

Standard ATN Timing Belt Versions

Belt Type	Tooth Profile	Pitch (mm)	Available Belt Width (mm)			
			25	50	75	100
ATN 10	AT	10	25	50	75	100
ATN 12.7	AT	12.7	25	50	75	100
ATN 20	AT	20	-	50	75	100
No. of inserts per tooth			1	2	3	4

Self-Tracking ATN Timing Belt Versions (Tracking Guide - K)

Available in ATN 10 K6 and ATN 12.7 K6

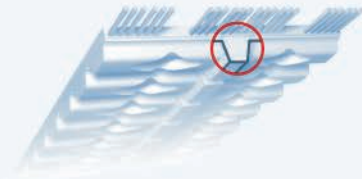

Timing Belt Widths and Self-Tracking Guide Positions

Belt Pitch \ Belt Width	50 mm	75 mm	100 mm
ATN 10 K6 - Tracking Guide Position	Symmetric	Asymmetric	Asymmetric
ATN 12.7 K6 - Tracking Guide Position	Symmetric	Asymmetric	Asymmetric

Measurements - ATN 10 K6 / ATN 12.7 K6

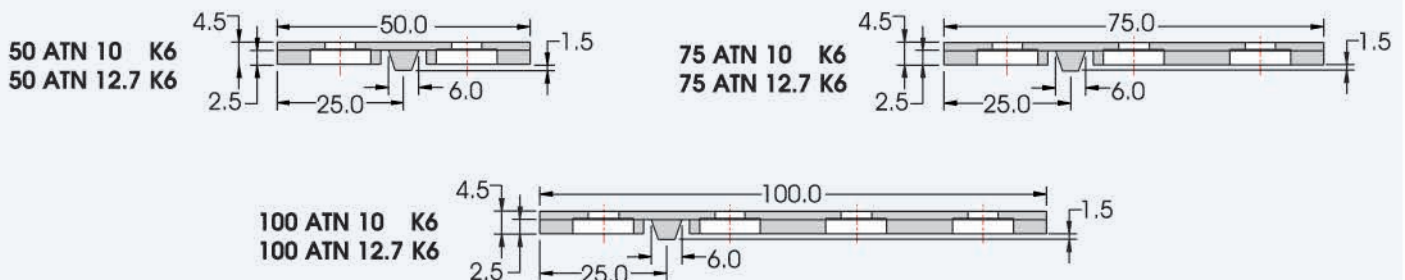

ATN - CONVERTIBLE TIMING BELT SYSTEM

PRODUCT RANGE

Open Ended and Welded Endless Base Timing Belts



Open Ended (to be clamped) - code M



Welded Endless - code V

Belt Lengths for Open Ended (M) and Welded Endless (V)

Belt Pitch \ Belt Version	Open Ended (M)	Welded Endless (V)
ATN 10 / ATN 12.7	Standard: 50 meter rolls Cut to length sizes available	Minimum length: 880 mm
ATN 20	Standard: 50 meter rolls Cut to length sizes available	Minimum length: 1000 mm

Available Belt Materials

Materials	TPU-ST1 Standard	TPU-ST2 Flexible at low temperature	TPU-KF1 Flexible at cold temperature	TPU-FDA1 Food Grade	TPU-WB High Temperature
Temperature Range	0°C to + 80°C +32° F to + 176° F	+ 5°C to + 50°C +41° F to + 122° F	- 25°C to + 5°C - 13° F to + 41° F	0°C to + 80°C +32° F to + 176° F	+20°C to + 110°C +68° F to + 230° F
Durometer - Shore A	92	85	85	92	94

Mass in kg per Meter of Belt Length

Pitch \ Width	Standard Version				Self-Tracking — K Version		
	25 mm	50 mm	75 mm	100 mm	50 mm	75 mm	100 mm
ATN 10	0.120	0.240	0.360	0.480	0.255	0.375	0.495
ATN 12.7	0.111	0.222	0.333	0.444	0.237	0.348	0.459
ATN 20	-	0.403	0.604	0.806	-	-	-

Note: Mass shown without inserts and screws

Available Nylon Facings

Tooth Side (PAZ), Belt Back (PAR), Both Sides (PAZ-PAR)

ATN - CONVERTIBLE TIMING BELT SYSTEM

CAVITIES

Spacing of Molded Cavities for Inserts — Standard Version

Pitch	Distance A between cavities along belt length (every tooth)	Distance between cavities across belt width
ATN 10	10 mm	25 mm
ATN 12.7	12.7 mm	25 mm
ATN 20	20 mm	25 mm
ATN 10 K6	10 mm	25 mm
ATN 12.7 K6	12.7 mm	25 mm

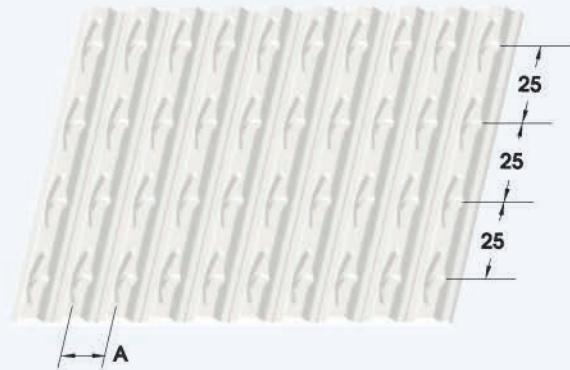

ORDERING EXAMPLE

	<u>50</u>	<u>ATN</u>	<u>10</u>	<u>/</u>	<u>12700</u>	<u>M</u>	<u>PAZ</u>	
	<u>75</u>	<u>ATN</u>	<u>10</u>	<u>K6</u>	<u>/</u>	<u>12700</u>	<u>V</u>	<u>PAR</u>
Width in mm	_____	_____	_____	_____	_____	_____	_____	_____
Type	_____	_____	_____	_____	_____	_____	_____	_____
Tooth Pitch	_____	_____	_____	_____	_____	_____	_____	_____
Self-Tracking Guide	_____	_____	_____	_____	_____	_____	_____	_____
Length in mm	_____	_____	_____	_____	_____	_____	_____	_____
Open Ended Code "M"	_____	_____	_____	_____	_____	_____	_____	_____
Spliced & Welded Endless Code "V"	_____	_____	_____	_____	_____	_____	_____	_____
Optional Nylon Facing on Tooth Side	_____	_____	_____	_____	_____	_____	_____	_____
Optional Nylon Facing on Belt Back	_____	_____	_____	_____	_____	_____	_____	_____

ATN - CONVERTIBLE TIMING BELT SYSTEM

INSERTS

Fastening Measurements

ATN 10 / ATN 12.7

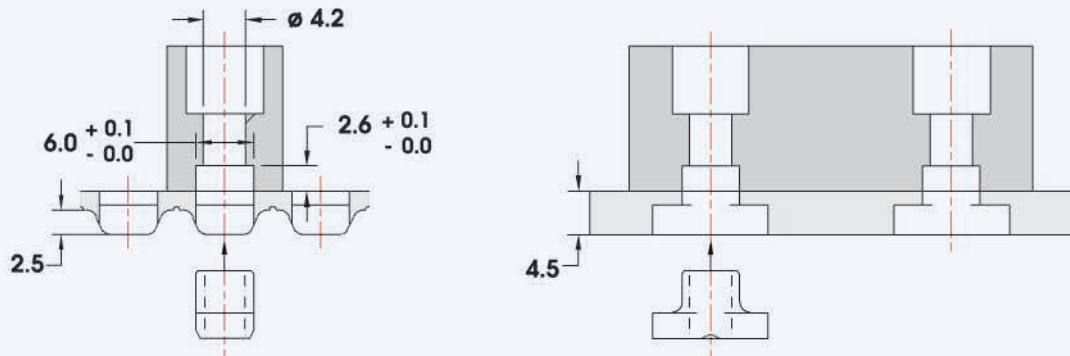

Fastening Measurements

ATN 20

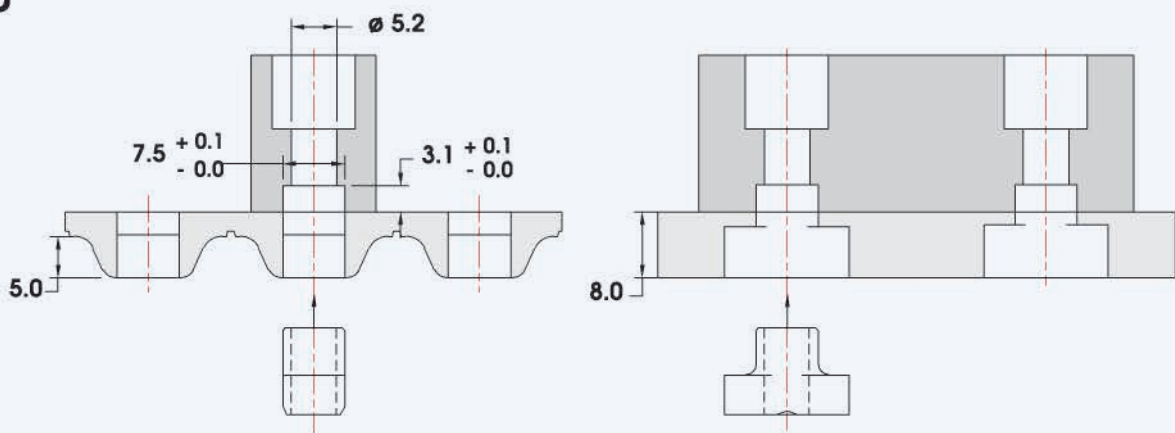





Insert Versions / Applications

Type	Material	Applications
Plastic	Polyamide	<ul style="list-style-type: none"> - small loads - normal temperatures - low dynamic loads
Brass	MS 58 F 36	<ul style="list-style-type: none"> - medium and large loads - low / high temperatures - higher dynamic loads
Stainless Steel	Stainless Steel	<ul style="list-style-type: none"> - medium and large loads - higher dynamic loads - FDA approved

ATN - CONVERTIBLE TIMING BELT SYSTEM

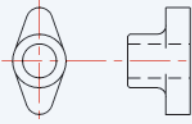
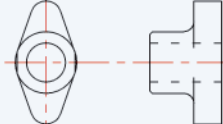
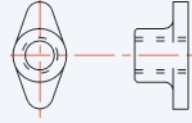
INSERTS

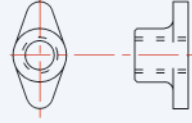
Insert Versions / Belt Pitch

Type	ATN 10 / ATN 12.7	ATN 20
Plastic	 <p>Order # BB4800001H per bag of 100 pcs.</p>	 <p>Order # BB4800003H per bag of 100 pcs.</p>
Brass	 <p>Order # BB4800002H per bag of 100 pcs.</p>	 <p>Order # BB4800004H per bag of 100 pcs.</p>
Stainless Steel	 <p>Order # BB48000030H per bag of 100 pcs.</p>	 <p>Order # BB48000031H per bag of 100 pcs.</p>

Maximum Screw Tightening Torque In Ncm

Insert Version	Belt Pitch	Profile Material		
		TPU 790	Polyamide	Metal
Plastic	ATN 10 / ATN 12.7 ATN 20	50 Ncm 80 Ncm	70 Ncm 100 Ncm	70 Ncm 100 Ncm
Brass	ATN 10 / ATN 12.7 ATN 20	- -	100 Ncm 150 Ncm	100 Ncm 150 Ncm
Stainless Steel	ATN 10 / ATN 12.7 ATN 20	- -	100 Ncm 150 Ncm	100 Ncm 150 Ncm

SCREWS

Screw Length - L / Profile Height - H

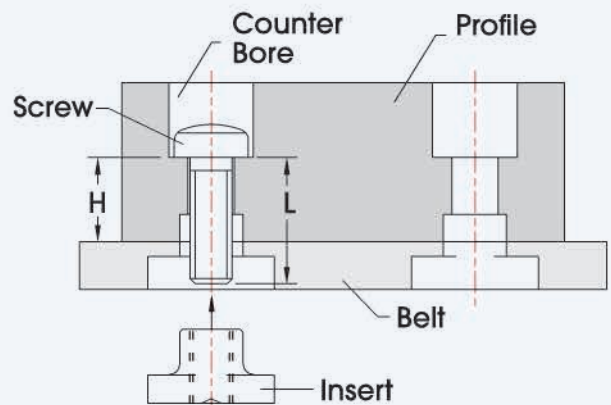
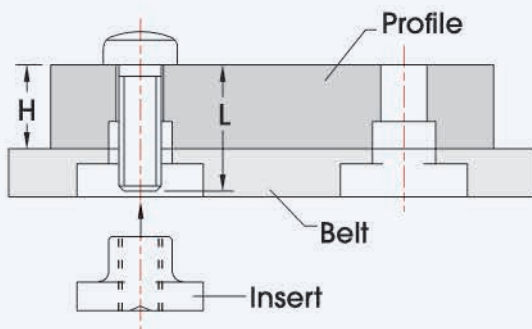

Note: Screws should not protrude beyond the inserts when assembled!

ATN - CONVERTIBLE TIMING BELT SYSTEM

SCREWS

ATN Mounting Screws — Steel Zinc Plated

Belt Pitch Insert Version	ATN 10 / ATN 12.7				ATN 20			
Plastic	Thread Forming				Thread Forming			
	Screw Type	Screw Length-L	Profile Height-H	Order Number*	Screw Type	Screw Length-L	Profile Height-H	Order Number*
	Z 40 x 8	8 mm	4 mm	BB4800006H	Z 50 x 12	12 mm	5 mm	BB4800009H
	Z 40 x 12	12 mm	8 mm	BB4800007H	Z 50 x 16	16 mm	9 mm	BB4800010H
	Z 40 x 16	16 mm	12 mm	BB4800008H	Z 50 x 20	20 mm	13 mm	BB4800011H
	* per bag of 100 pcs				* per bag of 100 pcs			
Brass	Threaded				Threaded			
	Screw Type	Screw Length-L	Profile Height-H	Order Number*	Screw Type	Screw Length-L	Profile Height-H	Order Number*
	M 4 x 8	8 mm	4 mm	BB4800013H	M 5 x 12	12 mm	5 mm	BB4800016H
	M 4 x 12	12 mm	8 mm	BB4800014H	M 5 x 16	16 mm	9 mm	BB4800017H
	M 4 x 16	16 mm	12 mm	BB4800015H	M 5 x 20	20 mm	13 mm	BB4800018H
	* per bag of 100 pcs				* per bag of 100 pcs			
Stainless Steel	Threaded				Threaded			
	Screw Type	Screw Length-L	Profile Height-H	Order Number*	Screw Type	Screw Length-L	Profile Height-H	Order Number*
	M 4 x 12	12 mm	8 mm	BB4800057H	M 5 x 16	16 mm	9 mm	BB4800061H
	* per bag of 100 pcs				* per bag of 100 pcs			

HAND PIERCING TOOLS

The base timing belt is extruded with a 0.2 mm thick polyurethane skin across the cavities. This skin must be pierced through to allow for profile attachment. ATN timing belts can be ordered from BRECOflex Co., L.L.C. with pierced holes (hole pattern must be specified). In order to pierce holes at the customer site, the following tools are available.

Piercing Tools

Belt Pitch	Punch Tool Version	Order Number
ATN 10 / ATN 12.7	6 mm	BB4800020H
ATN 20	7.5 mm	BB4800021H

Base Timing Belt

Polyurethane Skin

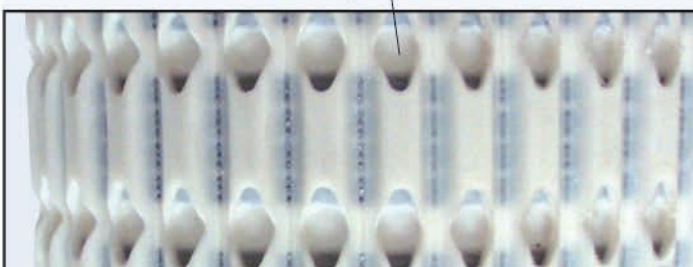

Piercing Tools for

ATN 20

ATN 10 / ATN 12.7

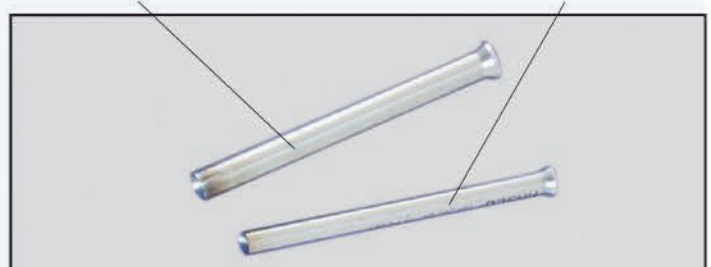

ATN - CONVERTIBLE TIMING BELT SYSTEM

STRENGTH CALCULATION

Profile Connection

$$F_{ZN} \leq F_{ZNzul}$$

F_{ZN} is the sum of all forces acting on each insert including applied, inertial, and centrifugal forces. These forces must be converted to equivalent normal forces (perpendicular to the belt surface) and added in order to compare against the values in the following table. (Allowable Force (F_{ZNzul}) per Insert in N).

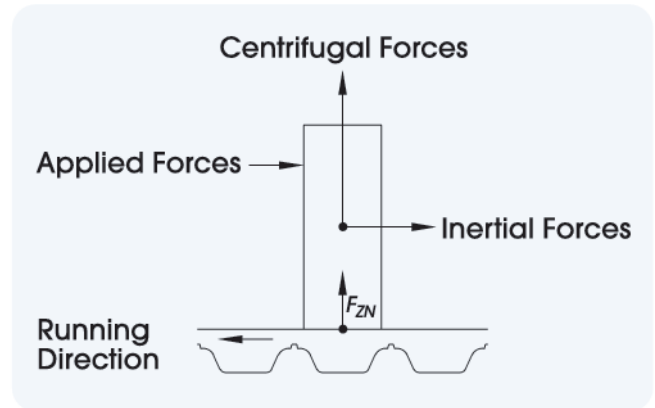

Allowable Force (F_{ZNzul}) per Insert in N (Perpendicular to Belt Surface)

Version	Pitch	Profile Material	
		Polyamide	Metal
Plastic	ATN 10 /ATN 12.7	100 N	100 N
	ATN 20	160 N	160 N
Brass	ATN 10 /ATN 12.7	170 N	320 N
	ATN 20	240 N	490 N
Stainless Steel	ATN 10 /ATN 12.7	170 N	320 N
	ATN 20	240 N	490 N

Centrifugal Forces - A force normal to the belt surface during circular motion as a result of centripetal acceleration. This force is dependent upon the profile and attachment mass, the path radius at the profile center of mass, and the pulley RPM.

Applied Forces - External forces on the profile due to the force from accelerating or supporting transported goods. Acceleration forces are dependent upon the mass of the goods and the magnitude of the acceleration. An example of an applied force is the force due to the weight of goods in vertical transport applications.

Inertial Forces - The resistive force exerted by the profile and attachments under acceleration and deceleration.

STRENGTH CALCULATION

Strength Calculation Method for Profile Design

1. For precise strength calculation, please call BRECOflex Applications Engineering.

2. For basic, approximate strength calculation, the following method can be used:

2.1 Defining the profile center mass height (h_{SN})

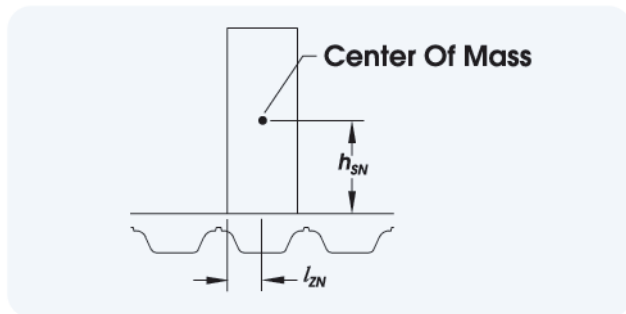

2.2 Graphs 1, 2 and 3 show the allowable center mass height of the profile for a given drive speed, profile mass, and pulley diameter. Select the particular graph based on the closest pulley pitch diameter of the smallest pulley in the drive set-up. Interpolate graph results for more accuracy.

2.3 Graphs are based on the following parameters:

- Belt version = 50 ATN 10 / ATN 12.7
- Symmetric profile support with $l_{ZN} = 10$ mm
- Plastic inserts with polyamide or metal profiles

Graph 1:

Pulley Pitch Diameter $d_O = 79.58$ mm

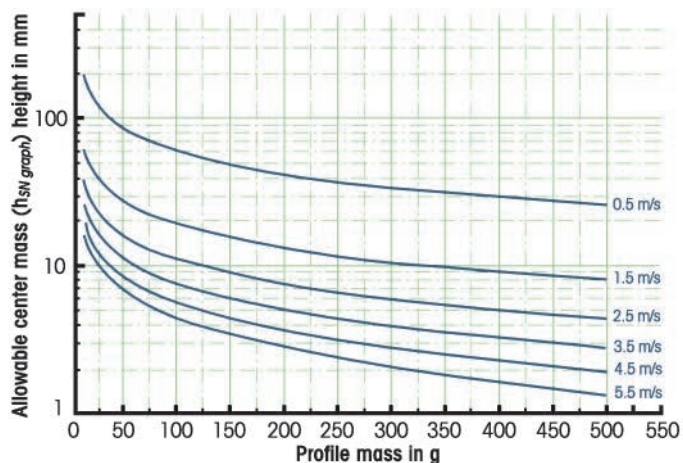

Graph 2:

Pulley Pitch Diameter $d_O = 127.32$ mm

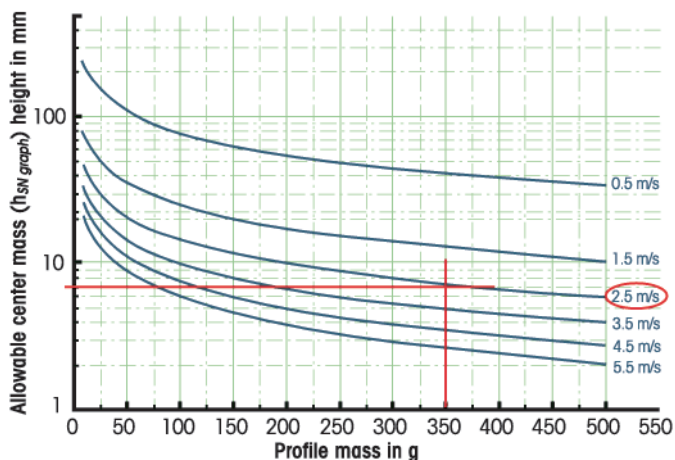

Graph 3:

Pulley Pitch Diameter $d_O = 190.99$ mm

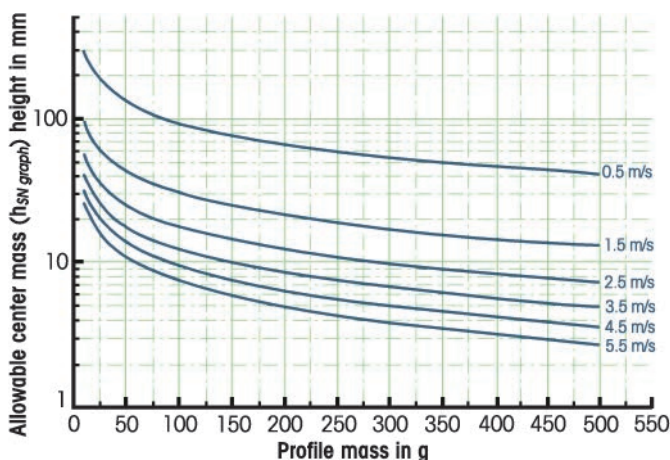

ATN - CONVERTIBLE TIMING BELT SYSTEM

STRENGTH CALCULATION

Strength Calculation Method for Profile Design

2.4 Calculation Example (no correction factors necessary)

2.4.1 Parameters

- Belt version = 50 ATN 10
- Pulley pitch diameter $d_O = 127.32$ mm
- Drive speed $v = 2.5$ m/s
- Profile mass $m_N = 350$ g
- Profile support with $l_{ZN} = 10$ mm
- Insert / profile material = polyamide / metal

Solution:

Use Graph 2 (see page 11) to obtain allowable profile mass height ($h_{SN\ graph} = \text{approx. } 7$ mm).

Note:

For this example, no correction factors are necessary, therefore, $h_{SN\ graph} = h_{SN\ zul}$.

$$h_{SN\ zul} = 7\text{ mm}$$

Allowable profile center of mass height ($h_{SN\ zul}$) 7 mm should not be exceeded.

2.5 Correction factors B, N_S , and M defined to calculate $h_{SN\ zul}$ for other configurations:

$$h_{SN\ zul} = h_{SN\ graph} (B \cdot N_S \cdot M)$$

2.5.1 Belt Width Factor (B)

Belt Width	Correction Factor B
25 mm	0.7
50 mm	1.0
75 mm	1.2
100 mm	1.4

2.5.2 Symmetric Profile Support Width Factor (N_S)

$$N_S = \sqrt{\frac{0.1 \cdot l_{ZN}\text{ mm}}{\text{mm}}}$$

2.5.3 Insert - Profile Material Factor (M)

	Insert Material	Profile Material	Correction Factor (M)
ATN 10 ATN 12.7	Polyamide	TPU 790	0.6
	Polyamide	Polyamide/Metal	1.0
	Brass	Polyamide	1.3
	Brass	Metal	1.8
	Stainless Steel	Polyamide	1.3
	Stainless Steel	Metal	1.8
ATN 20	Polyamide	Polyamide / Metal	1.3
	Brass	Polyamide	1.5
	Brass	Metal	2.2
	Stainless Steel	Polyamide	1.5
	Stainless Steel	Metal	2.2

STRENGTH CALCULATION

2.6 Calculation Example (correction factors necessary)

2.6.1 Parameters

- Belt version = 75 ATN 10
- Pulley pitch diameter $d_O = 134$ mm
- Drive speed $v = 2.5$ m/s
- Profile mass $m_N = 350$ g
- Profile support width $l_{ZN} = 15$ mm
- Insert / profile material = brass / metal

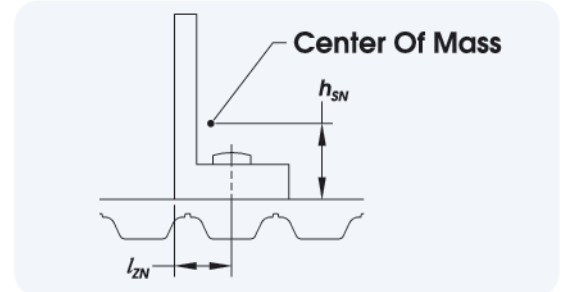

Solution:

Use Graph 2 (see page 11) to obtain allowable profile mass height ($h_{SN\ graph}$).
Determine correction factors B , N_S and M to calculate $h_{SN\ zul}$.

$$h_{SN\ zul} = h_{SN\ graph} (B \cdot N_S \cdot M)$$

$$h_{SN\ zul} = 7\text{ mm} \left(1.2 \cdot \sqrt{\frac{0.1 \cdot 15\text{ mm}}{\text{mm}}} \cdot 1.8 \right)$$

$$h_{SN\ zul} = 18.5\text{ mm}$$

Allowable profile center of mass height ($h_{SN\ zul}$) 18.5 mm should not be exceeded.



ATN - CONVERTIBLE TIMING BELT SYSTEM

STRENGTH CALCULATION

TOOTH SHEAR STRENGTH

Peripheral Force Calculation

The peripheral force (F_U) is based on the specific peripheral force ($F_{U\text{ spez}}$) and the number of teeth in mesh (Z_e) on the drive pulley. $Z_e \text{ max} = 12$ teeth for open-ended belts. $Z_e \text{ max} = 6$ teeth for welded endless belts.

$$F_U = F_{U\text{ spez}} \cdot Z_e$$

F_U = Peripheral Force in N

$$F_{U\text{ spez}} = \frac{F_U}{Z_e}$$

$F_{U\text{ spez}}$ = Specific Peripheral Force in N per Tooth in Mesh
(Charts below show the different values for each belt width.)

$$Z_e = \frac{F_U}{F_{U\text{ spez}}}$$

Z_e = Number of Teeth in Mesh

Specific Peripheral Force ($F_{U\text{ spez}}$) per One Tooth in Mesh in N

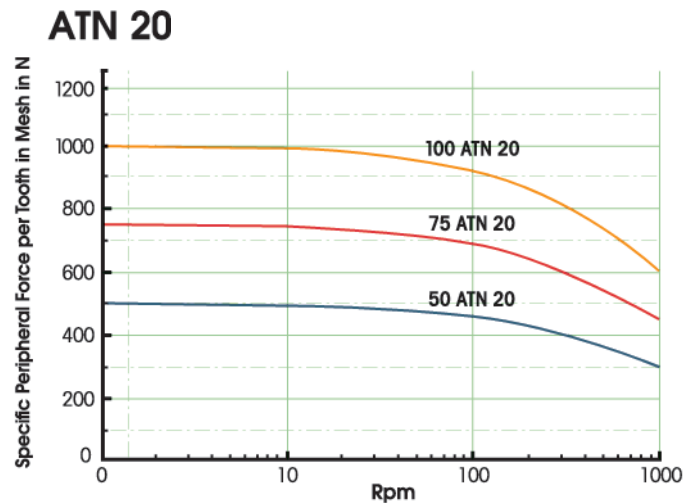
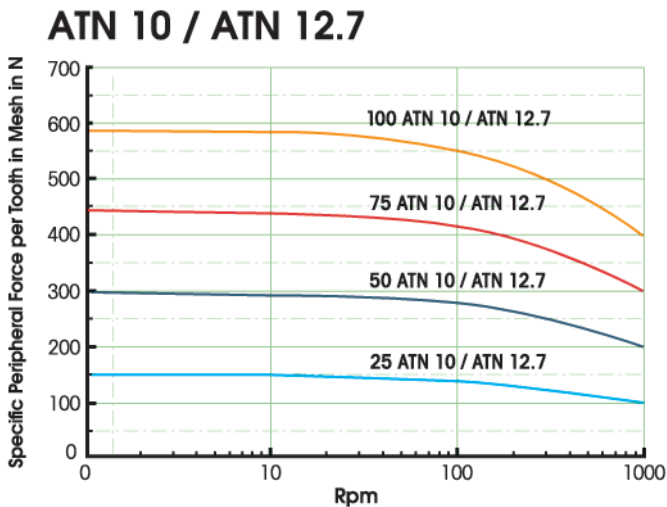

SELF-TRACKING ATN TIMING BELT VERSIONS (TRACKING GUIDE - K)

Comparison - Specific Peripheral Force per Tooth in Mesh

Self-Tracking Versions	$F_{U\text{ spez}}$ compared to standard ATN 10 / ATN 12.7
50 ATN 10 K6 / ATN 12.7 K6	-20%
75 ATN 10 K6 / ATN 12.7 K6	-13%
100 ATN 10 K6 / ATN 12.7 K6	-10%

ATN - CONVERTIBLE TIMING BELT SYSTEM

TENSILE STRENGTH

Open Ended ATN Timing Belts — M
 Allowable Tensile Load of Belt Cross Section, F_{zul} in N

Belt Pitch \ Belt Width	25 mm	50 mm	75 mm	100 mm
ATN 10	3000	6000	9000	12000
ATN 12.7	3000	6000	9000	12000
ATN 20	-	8000	12000	16000

Welded Endless ATN Timing Belts - V
 Allowable Tensile Load of Belt Cross Section, F_{zul} in N

Belt Pitch \ Belt Width	25 mm	50 mm	75 mm	100 mm
ATN 10	1000	2000	3000	4000
ATN 12.7	1000	2000	3000	4000
ATN 20	-	2700	4000	5400

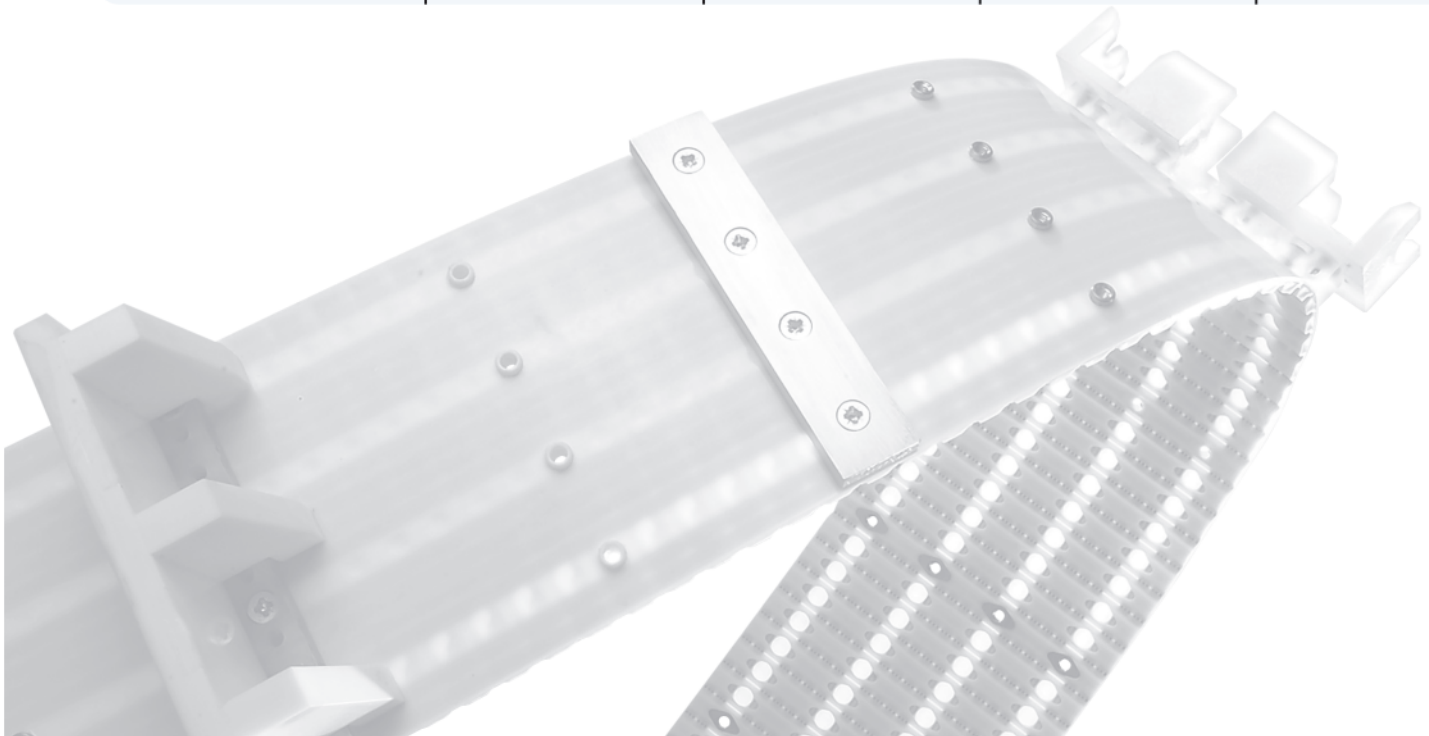

ATN - CONVERTIBLE TIMING BELT SYSTEM

STANDARD PROFILES

ATN - Standard Adapter Profiles

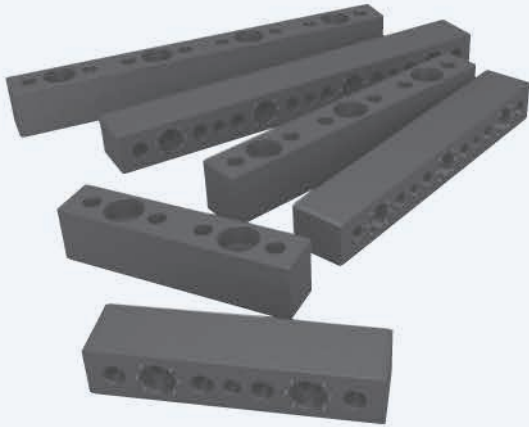

Attaching profiles to the ATN Timing belt can be accomplished in two ways. Profiles can either be screwed onto an adapter profile or screwed directly to the belt. Using an adapter is necessary when it is not possible to screw the profile directly to the belt.

The adapters shown provide a secure attachment for profiles to be either screwed on or slid on (e.g. T-Slot, dovetail). That way, a quick and easy way to replace or change profiles is possible.

The adapters do not have to be replaced when changing profiles.

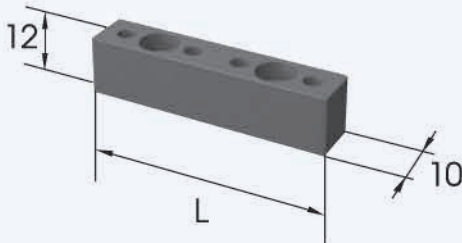

R-Profile

Profile Type	Profile Length L	Profile Number
R-Profile	50 mm	1.001.008
R-Profile	75 mm	1.001.009
R-Profile	100 mm	1.001.010

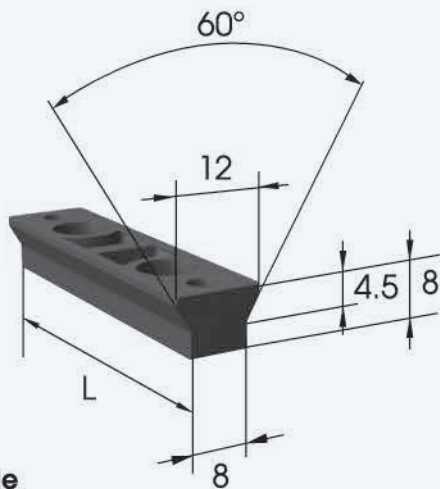

Y-Profile

Profile Type	Profile Length L	Profile Number
Y-Profile	50 mm	1.001.002
Y-Profile	75 mm	1.001.003
Y-Profile	100 mm	1.001.004

ATN - CONVERTIBLE TIMING BELT SYSTEM

STANDARD PROFILES

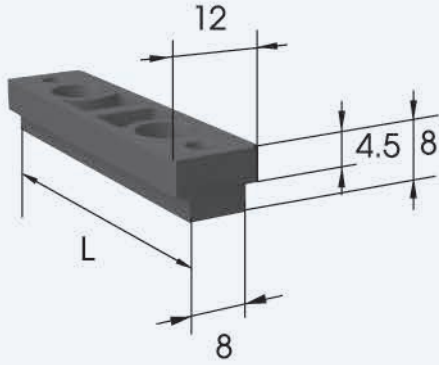

T-Profile

Profile Type	Profile Length L	Profile Number
T-Profile	50 mm	1.001.005
T-Profile	75 mm	1.001.006
T-Profile	100 mm	1.001.007

ATN - Custom Profile Examples

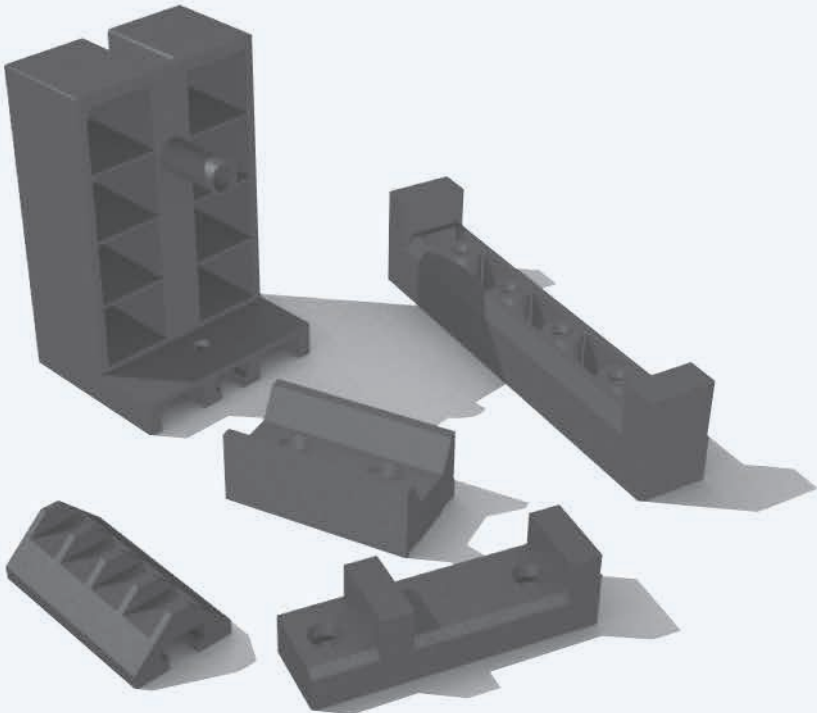

The profiles shown are a few examples of already existing custom ATN profiles.

BRECOflex CO., L.L.C. has the know-how and technical capabilities to provide the perfect profile solution for your conveying application.

Please contact Applications Engineering for custom ATN profiles.

ATN - CONVERTIBLE TIMING BELT SYSTEM

ATN - CONNECTING KIT FOR FIELD ASSEMBLY

This mechanical connection is designed for rapid belt assembly and disassembly in the field directly on the drive system. The finger spliced ends of the timing belt are prepared to be clamped together with special clamping hardware. The hardware consists of high strength polyamide inserts, high grade steel plates, and the requisite screws. This connection technology allows ATN profiles to be attached even in the joined area. Profiles for the joined area may have to be modified.

Prepared Finger Spliced Timing Belt Ends

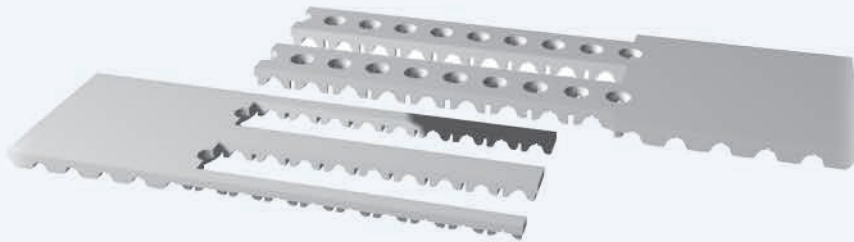

Assembly — Connection Method



Completed Connection (Endless Belt)

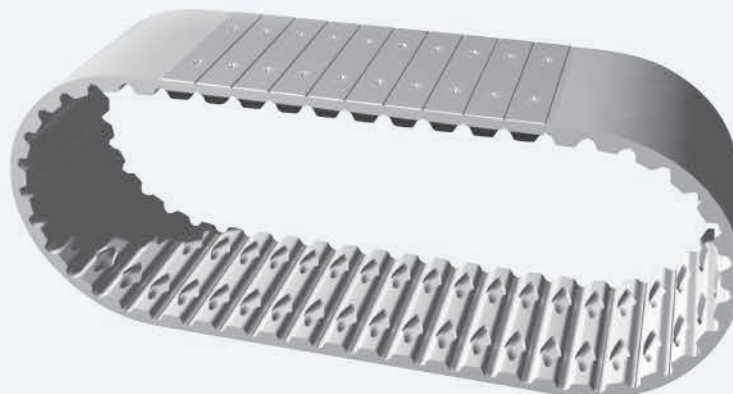

ATN - CONVERTIBLE TIMING BELT SYSTEM

ATN - CONNECTING KIT FOR FIELD ASSEMBLY

Connection Parts: Features / Specifications

Number of connection elements per connection:	10
Insert material:	high strength polyamide
Connection plates:	high grade steel, hardened and polished
Connection plate thickness:	0.9 mm
Mounting screws:	M 2.5

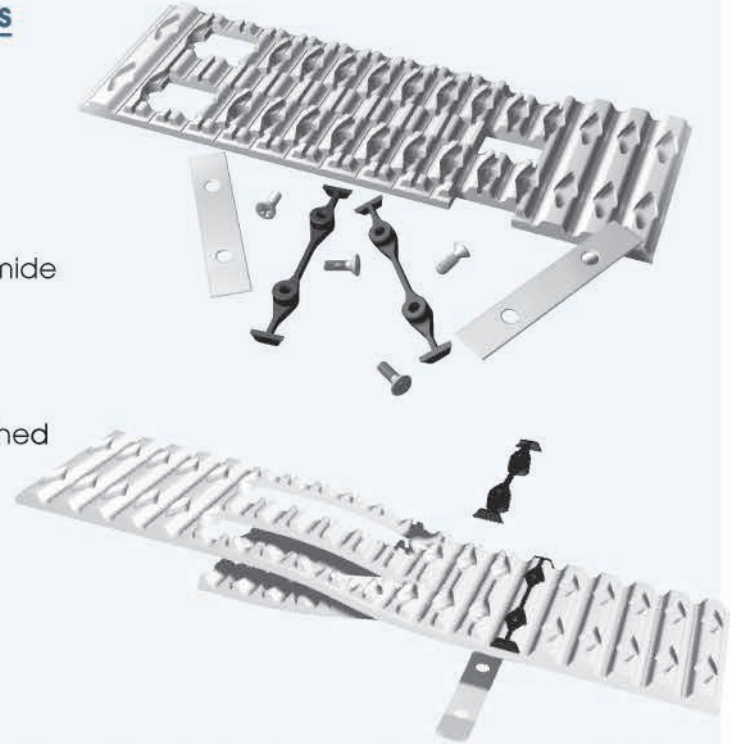

Note: Customized belt version with recessed connection plates for level conveying surface available

Allowable Tensile Load (F_{zu} in N)

Belt Pitch \ Belt Width	50 mm	75 mm	100 mm
ATN 10 / ATN 10 K6	750 N	1150 N	1500 N
ATN 12.7 / ATN 12.7 K6	750 N	1150 N	1500 N
ATN 20	1000 N	1500 N	2000 N

Minimum Number of Pulley Teeth Required (for clamped belts)

Belt Pitch	Z min
ATN 10	25
ATN 10 K6	
ATN 12.7	20
ATN 12.7 K6	

ATN - CONVERTIBLE TIMING BELT SYSTEM

ATN CONNECTING KIT VERSIONS

Version "C" (standard)

- Available for ATN 10, ATN 12.7, ATN 10 K6 and ATN 12.7 K6
- Belt thickness (without self-tracking guide):
4.5 mm (standard thickness)
- Number of connection elements per connection:
10
- Not suitable for mounting of profiles in connecting kit area

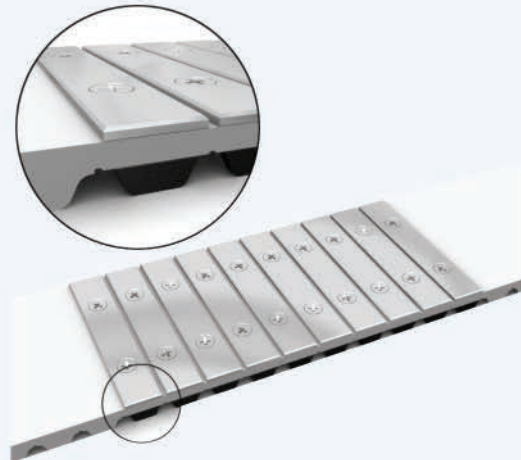

Version "DC" (deep connection)

- Available for ATN 10, ATN 12.7, ATN 20, ATN 10 K6 and ATN 12.7 K6
- Belt thickness (without self-tracking guide):
5.4 mm (ATN 10, ATN 12.7)
8.0 mm (ATN 20)
- Number of connection elements per connection:
10 (ATN 10, ATN 12.7)
9 (ATN 20)
- Not suitable for mounting of profiles in connecting kit area

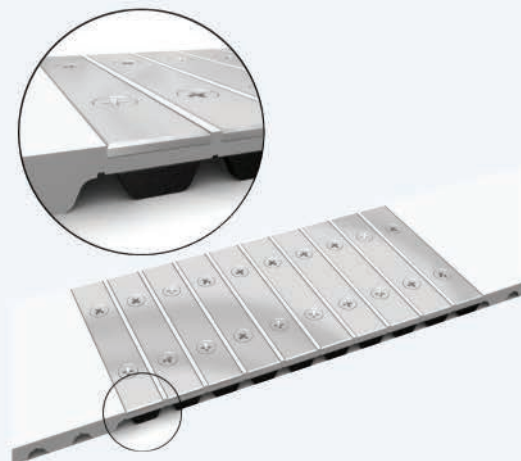

Version "DC-PRO" (deep connection for profiles)

- Available for ATN 10, ATN 12.7, ATN 20, ATN 10 K6 and ATN 12.7 K6
- Belt thickness (without self-tracking guide):
5.4 mm (ATN 10, ATN 12.7)
8.0 mm (ATN 20)
- Number of connection elements per connection:
10 (ATN 10, ATN 12.7)
9 (ATN 20)
- Suitable for mounting of profiles in connecting kit area

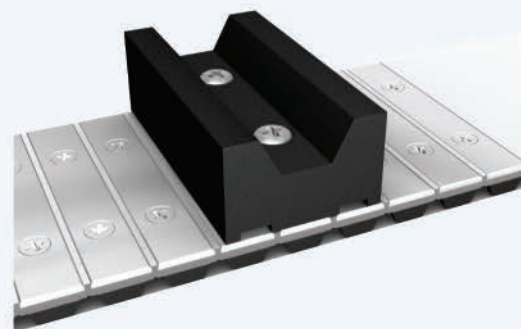

ATN - CONVERTIBLE TIMING BELT SYSTEM

ATN CONNECTING KIT VERSIONS

Availability

Connecting Kits Version	ATN 10	ATN 12.7	ATN 20	ATN 10 K6	ATN 12.7 K6
C	•	•	-	•	•
DC	•	•	•	•	•
DC-PRO	•	•	•	•	•

Connecting Kits for Belt Widths	ATN 10	ATN 12.7	ATN 20	ATN 10 K6	ATN 12.7 K6
25	-	-	-	-	-
50	•	•	•	•	•
75	•	•	•	•	•
100	•	•	•	•	•

SELF-TRACKING PULLEYS

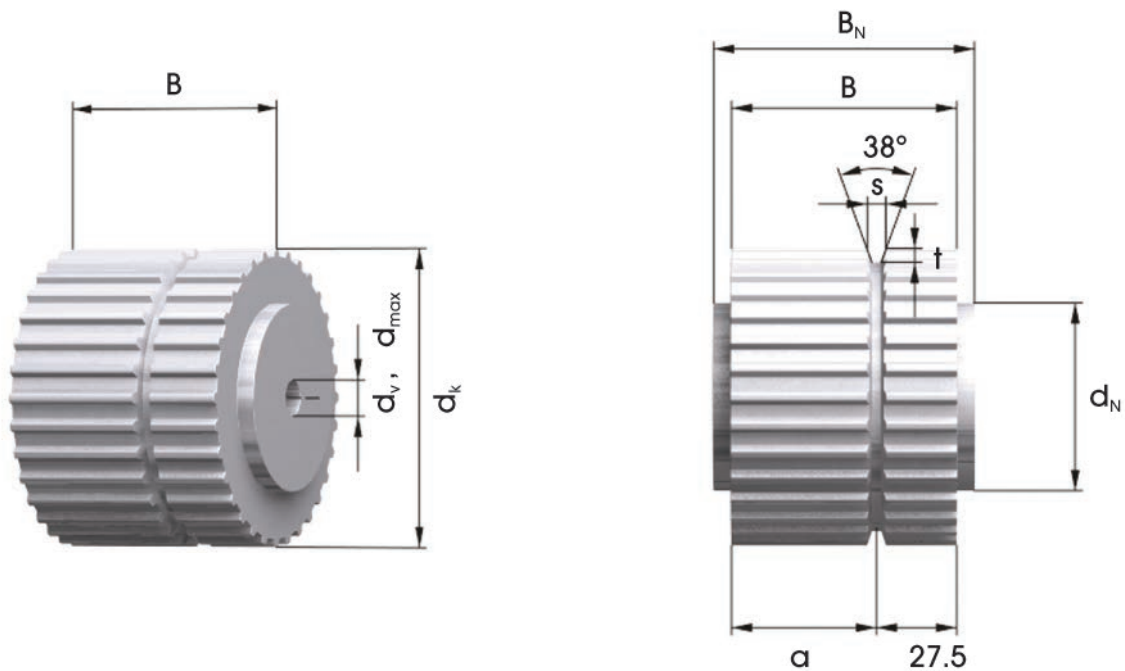

Self-Tracking Pulleys for ATN 10 K6 and ATN 12.7 K6

Belt Pitch	b [mm]	50	75	100
Pulley Face Width	B [mm]	55	80	105
Pulley Width over Hub	B _N [mm]	65	90	115
Toothed Width	a [mm]	27.5	52.5	77.5
Groove Width	s [mm]	6.5	6.5	6.5
Groove Depth	t [mm]	5	5	5

ATN - CONVERTIBLE TIMING BELT SYSTEM

ALUMINUM STOCK PULLEYS

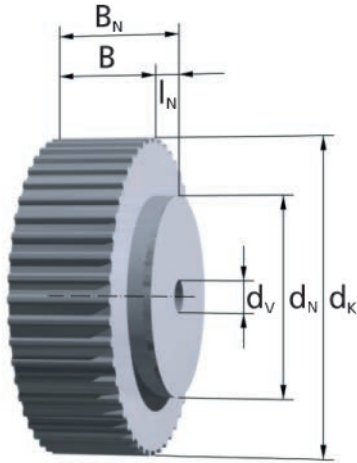

Type - 0

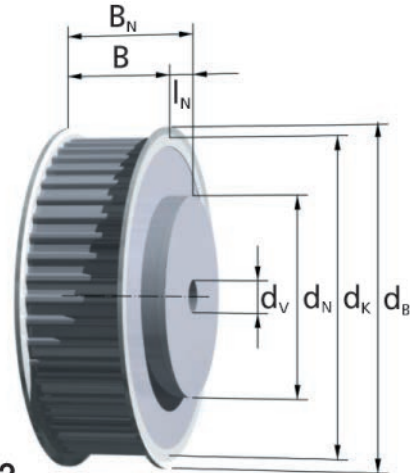

Type - 2

Tooth Type	# of Teeth	Outside Diameter	Pitch Diameter	Flange Diameter	Face Width	Pulley Width	Pilot Bore	Hub Size	Part Number
ATN 10	z	d _k	d _o	d _b	B	B _N	d _v	d _N X l _N	
BELT WIDTH = 25 mm	25	77.75	79.58	82	32	42	12H7	60 x 10	LS 42 AT 10 / 25 - 2 hub 60 x 10
	27	84.10	85.95	90	32	42	12H7	60 x 10	LS 42 AT 10 / 27 - 2 hub 60 x 10
	30	93.65	95.49	99	32	42	12H7	60 x 10	LS 42 AT 10 / 30 - 2 hub 60 x 10
	32	100.00	101.86	105	32	42	12H7	65 x 10	LS 42 AT 10 / 32 - 2 hub 65 x 10
	36	112.75	114.59	118	32	42	16H7	70 x 10	LS 42 AT 10 / 36 - 2 hub 70 x 10
	40	125.45	127.32	131	32	42	16H7	80 x 10	LS 42 AT 10 / 40 - 2 hub 80 x 10
	44	138.20	140.05	144	32	42	16H7	90 x 10	LS 42 AT 10 / 44 - 2 hub 90 x 10
	48	150.95	152.78	-	32	42	16H7	95 x 10	LS 42 AT 10 / 48 - 0 hub 95 x 10
60	189.10	190.98	-	32	42	16H7	110 x 10	LS 42 AT 10 / 60 - 0 hub 110x10	
ATN 10	z	d _k	d _o	d _b	B	B _N	d _v	d _N X l _N	
BELT WIDTH = 50 mm	25	77.75	79.58	82	60	70	12H7	60 x 10	LS 70 AT 10 / 25 - 2 hub 60 x 10
	27	84.10	85.95	90	60	70	12H7	60 x 10	LS 70 AT 10 / 27 - 2 hub 60 x 10
	30	93.65	95.49	99	60	70	12H7	60 x 10	LS 70 AT 10 / 30 - 2 hub 60 x 10
	32	100.00	101.86	105	60	70	12H7	65 x 10	LS 70 AT 10 / 32 - 2 hub 65 x 10
	36	112.75	114.59	118	60	70	16H7	70 x 10	LS 70 AT 10 / 36 - 2 hub 70 x 10
	40	125.45	127.32	131	60	70	16H7	80 x 10	LS 70 AT 10 / 40 - 2 hub 80 x 10
	44	138.20	140.05	144	60	70	16H7	90 x 10	LS 70 AT 10 / 44 - 2 hub 90 x 10
	48	150.95	152.78	-	60	70	16H7	95 x 10	LS 70 AT 10 / 48 - 0 hub 95 x 10
	60	189.10	190.98	-	60	70	16H7	110 x 10	LS 70 AT 10 / 60 - 0 hub 110x10

Note: Pulleys listed are stock items.

All dimensions in millimeters (mm).

Tooth Type	# of Teeth	Outside Diameter	Pitch Diameter	Flange Diameter	Face Width	Pulley Width	Pilot Bore	Hub Size	Part Number
ATN 12.7 ATN 20	z	d _k	d _o	d _b	B	B _N	d _v	d _N X l _N	Custom – Please call for technical assistance.

Note: H (T1/2") pitched pulleys are not compatible with ATN 12.7 belts. See page 4 for drawings of ATN tooth pitches and tooth profiles.

ATN - CONVERTIBLE TIMING BELT SYSTEM

ALUMINUM BAR STOCK



ALUMINUM CUSTOM PULLEYS

BRECOflex CO., L.L.C has the know-how and technical capabilities to supply practically any pulley design that is required for the most intricate applications. If it is technically feasible, BRECOflex CO., L.L.C. will be able to supply it no matter what size, material or detail is desired. A drawing of a custom pulley is shown with additional machining operations.

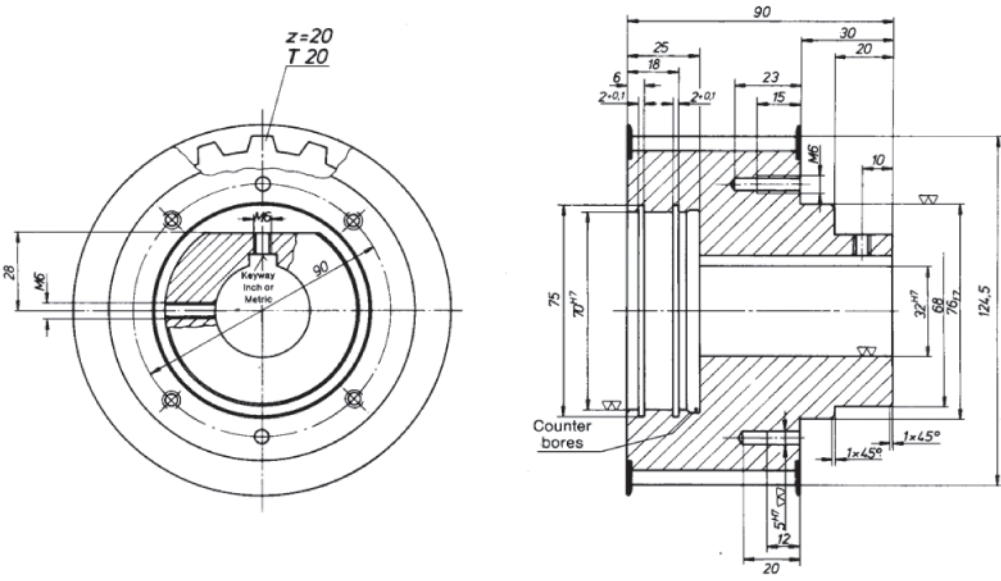

Minimum Pulley Sizes

Belt Pitch	Minimum Number of Teeth — z_{min}
ATN 10	25
ATN 12.7	20
ATN 20	20

Belt Drive with Flat Idler Running on Tooth Side

Belt Pitch	Minimum Diameter
ATN 10	80 mm
ATN 12.7	80 mm
ATN 20	130 mm

BRECOflex CO., L.L.C. Product Catalogs

ISO 9001
CERTIFIED
COMPANY



Polyurethane Timing Belts with Weld-on Profiles

Dividing, Stepping, Positioning.

Catalog #B203

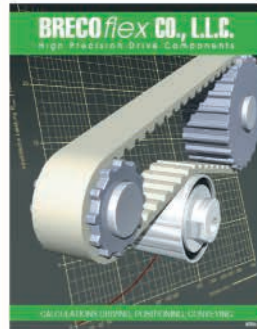

Calculations Driving, Positioning, Conveying

Power, Torque, and Peripheral Force calculations.

Catalog #B204



Accessory Items for Polyurethane Timing Belts

Pulleys, Tensioners, Clamps, Slide Beds.

Catalog #B205



Tension Meter

Improve Performance, life-time, positioning accuracy, bearing load, and noise level.

Catalog #B207

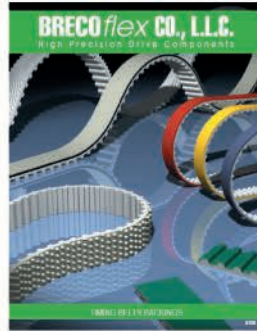

Timing Belts Backings

Polyurethane Timing Belts in Metric and English pitches with a wide range of cover materials.

Catalog #B208

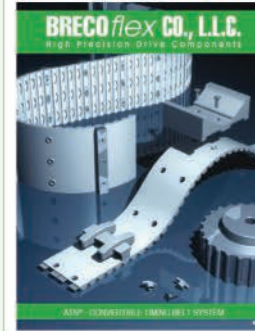

ATN® - Convertible Timing Belt System

ATN technology allows the reconfiguration of profiled timing belts at the customer site.

Catalog #B209



ESBAND Truly Endless Woven Flat Belts

Wide variety of Polyurethane, Neoprene and Silicone state-of-the-art flat belts.

Catalog #B210



Polyurethane Timing Belts

Main Catalog (184 pages) Metric and English Pitches.

Catalog #B212



Pulleys for Polyurethane and Neoprene Timing Belts

Finished pulleys and stock pulley program.

Catalog #B216



ARC-POWER Technology

ARC-POWER Technology Best Performing Timing Belts Available.

Catalog #B217

BRECOflex CO., L.L.C.

High Precision Drive Components

222 Industrial Way West • Eatontown • NJ 07724

Tel: 732-460-9500 • Fax: 732-542-6725

www.brecoflex.com

email: info@brecoflex.com

Copyright 2003 BRECOflex CO., L.L.C. • BRECO®, BRECOFLEX® & ATN® are registered trademarks of BRECO Antriebstechnik GmbH • ARC-POWER® is a registered trademark of BRECOflex CO., L.L.C. • Kevlar® is a registered trademark of DuPont Patents Pending • ESBAND® is a registered trademark of Max Schlatterer GmbH & Co. KG Patents Pending. Specifications are subject to change without prior notice.

All recommendations for the use of the products described herein and all other data or information set forth in this publication, whether concerning such products or otherwise, are furnished without any guarantee, warranty representations or inducement of any kind whether expressed or implied, including but not limited to warranties of merchantability and fitness for a particular purpose. BRECOflex CO., L.L.C. expressly disclaims liability under any theory, including without limitation, contract negligence, misrepresentation or breach of any obligation relating to the recommendation, data or information set forth herein. Readers and customers are encouraged to conduct their own test before using any product. Read its label and all related instructions. BRECOflex CO., L.L.C. reserves the right to make changes in the technical and dimensional specifications of its products without prior notice. Responsibility for expenses incurred as a result of product changes or discontinuance of a product lies solely with the purchaser.