

 **MAVILOR**

INFRANOR GROUP COMPANY



## Motors

ISSUE 2001

# DC Servo Motors MSS Series

- Ratings to 6,000 RPM.
- Compact Length.
- Zero Cogging.
- Acceleration Torques to 10 x Rated.

MAVILOR's axial air gap dish armature is specially suited for high response servo drives. High torque to inertia ratio and smooth, non cogging torque low speed velocity control makes MAVILOR the motor of choice for the most exacting applications.

The MAVILOR MSS Series servomotors provide a 20% increase in power to weight and volume ratios and a 20% increase in power rate and acceleration capability over previous designs.

Incorporating an ironless rotor design, these industrial strength motors have an extremely long brush life and high efficiency.

MAVILOR MSS Series motors incorporate options of tachometers and fail-safe holding brakes within the motor structure, and in many cases are half the length of equivalently rated conventional motors.



## Dimensions

	MSS-2	MSS-4	MSS-6	MSS-8	MSS-12	MSS-22	MSS-35	MSS-45
A	131.5	129.5		140	139.5	167.5		193
B	23		30			50		60
C	122.5	120.5		131	127.5	155.5		181
D			9					12
E	4		3.5					4.5
F (DIN 933)	M3x10		M4x16			M8x16		M10x22
G (DIN 6885)	A4x4x14		A5x5x20					A8x7x32
H	3		2					3.5
I	235	233		243.5	237.5	265.5		291
J (j6)	ø80		ø95			ø130		ø180
K (j6)	ø110		ø130		ø180	ø230		ø250
L	ø118	ø140	ø168	ø192	ø212	ø275		ø305
M	4xM6 ø100		4xM6 ø115		4xM8 ø165	4xM10 ø165		4xM12 ø215
N (h11)	ø149 □119	ø200 □154	ø210 □170	ø205 □176	ø250 □206	ø300 □258		ø350 □284
P	4xø9 ø130	4xø11 ø165	4xø11 ø180		4xø14 ø215	4xø14 ø265		4xø18 ø300
Q (h9)	4		5					8
R (g6)	11		14			24		28
S ( $\begin{smallmatrix} 0 \\ -0.1 \end{smallmatrix}$ )	12.7		16			27		31
T					ø101			
V	8			10		11		14
W	10.5	13	13.5	14		12.5		14
X			35.5					33
Z					77			



Available CSA-US certified

# Technical Specifications

ALL CHARACTERISTICS MEASURED AT 40°C AMBIENT TEMPERATURE EXCEPT TERMINAL RESISTANCE (25°C)

	SYMBOLS	UNITS	MSS-2	MSS-4	MSS-6	MSS-8	MSS-12	MSS-22	MSS-35	MSS-45
RATED SPEED	n	rpm	3,000	3,000	3,000	3,000	3,000	3,000	3,000	3,000
RATED VOLTAGE ±5%	U	V	39.4	67	67.8	89.7	106.7	181	200	224
RATED CURRENT	I	A	6.5	7.8	10.7	10.7	14	16	19.5	21
RATED OUTPUT POWER (1)	P	W	190.3	397	575	805	1,240	2,573	3,525	4,274
EFFICIENCY	$\eta$	%	74	76	80	84	83	89	90	91
RATED TORQUE	T	Nm	0.6	1.26	1.83	2.56	3.95	8.19	11.23	13.6
MAXIMUM TORQUE (2)	T <sub>max</sub>	Nm	3.6	7.58	11	15.38	23.7	49.14	67.38	81.6
MAXIMUM SPEED (3)	n max	rpm	7,000	6,000	6,000	5,000	4,500	4,000	4,000	4,000
EMF CONSTANT ±5%	K <sub>E</sub>	V/1000 rpm	10.4	18	19	26.3	30.85	55.6	62.53	70
TORQUE CONSTANT ±5%	K <sub>T</sub>	Nm/A	0.099	0.172	0.181	0.251	0.295	0.53	0.597	0.668
FRICTION TORQUE	T <sub>F</sub>	Nm	0.03	0.05	0.05	0.06	0.09	0.09	0.11	0.11
DAMPING CONSTANT	K <sub>D</sub>	Nm/1000 rpm	0.003	0.009	0.018	0.021	0.02	0.05	0.1	0.11
TERMINAL RESISTANCE (25°C)	R	$\Omega$	1	1.25	0.75	0.82	0.75	0.67	0.51	0.51
ARMATURE INDUCTANCE	L	$\mu$ H	<102	<130	<120	<150	<200	<250	<300	<300
INERTIA	J	kg m <sup>2</sup> 10 <sup>-3</sup>	0.15	0.37	0.40	0.82	1.7	5.1	8.5	8.5
MECHANICAL TIME CONSTANT	T <sub>M</sub>	ms	14.38	15	9	10.17	14	11.6	11.6	9.3
TRANSITORY POWER	P <sub>S</sub>	kW/s	89	155	300	288	330	473	534	783
THERMAL TIME CONSTANT ROTOR TO HOUSING	T <sub>AC</sub>	s	170	180	190	200	300	360	650	650
THERMAL TIME CONSTANT (1) HOUSING TO AMBIENT	T <sub>CA</sub>	s	1,700	1,750	1,800	2,000	2,700	3,000	4,000	4,000
THERMAL RESISTANCE ROTOR TO HOUSING	R <sub>AC</sub>	°C/W	0.8	0.5	0.5	0.5	0.3	0.2	0.13	0.15
THERMAL RESISTANCE (1) HOUSING TO AMBIENT	R <sub>CA</sub>	°C/W	0.5	0.3	0.4	0.4	0.3	0.2	0.14	0.15
RADIAL LOAD (at mid-length of shaft)	F <sub>R</sub>	N	200	200	300	300	500	600	700	700
AXIAL LOAD	F <sub>A</sub>	N	150	200	200	200	250	400	400	400
MASS (Only motor. No options)	M	kg	3.3	4.5	5.8	8	10	16	22	24
			300x300x10		400x400x10			500x500x10		
			3	3.5	4	7	10			
			9,000		6,000		4,500			

(1) With an aluminium heat sink plate

(2) For an S3 cycle

(3) Maximum speed in continuous service. During a very short time (r.p.m.)

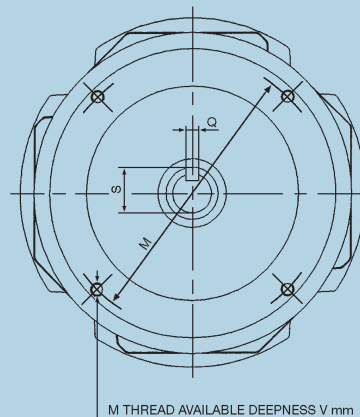
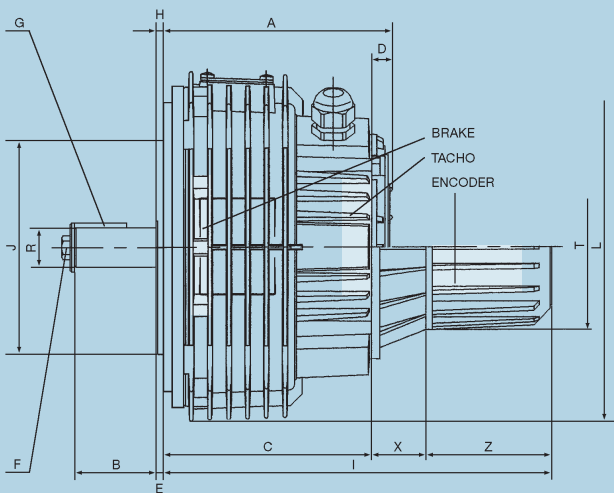

FLANGE B-14

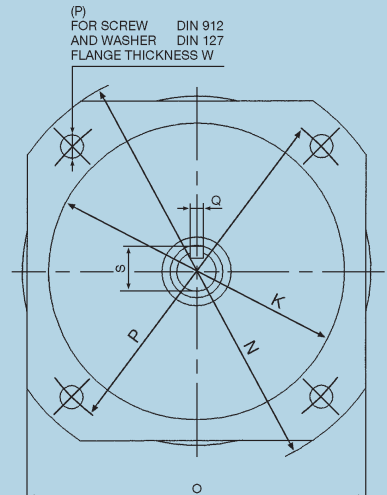

FLANGE B-5 (OPTIONAL)

(P) FOR SCREW DIN 912 AND WASHER DIN 127 FLANGE THICKNESS W

## Options

MODEL	Tachometer Type	Brake Type
<b>MSS-2</b>	D40	04
<b>MSS-4</b>	D40	06
<b>MSS-6</b>	D40	06
<b>MSS-8</b>	D40	06
<b>MSS-12</b>	D40	07
<b>MSS-22</b>	D26	09
<b>MSS-35</b>	D26	11
<b>MSS-45</b>	D26	11

## Tachometer Specifications

	UNITS	TYPE	
		D40	D26
Voltage Constant	V/krpm	10 ± 5%*	10 ± 5%*
Ripple @ 1000 rpm (pp)	%	<1.5	<1.2
Linearity @ 6000 rpm	%	≤0.1	≤0.1
Reversing Error	%	≤0.12	≤0.12
Temperature Coefficient	%/°C	0.03	0.02
Rotor Inertia	kg m <sup>2</sup> 10 <sup>-3</sup>	0.004	0.024
Resistance	Ω	86	90
Inductance	mH	13	25
Current	mA	2	4
Maximum Current	mA	8	17
Maximum Speed	rpm	9,000	8,000
Mass	kg	0.105	0.295

\*other voltages available

## Brake Specifications

	UNITS	TYPE				
		04	06	07	09	11
Holding Torque	Nm	1.2	2.5	5	12	20
DC Voltage	V	24	24	24	24	24
Input Power	W	8	12	16	18	22
Inertia	kg cm <sup>2</sup>	0.05	0.23	0.65	2.14	5.7
Response Time						
Disengagement	ms	4	7	15	30	55
Engagement	ms	3	5	7	13	18
Mass	kg	0.19	0.3	0.6	1.1	1.9

Performance curves shown right indicate the continuous operating zone or torque-speed envelope for 40°C ambient conditions. For MAVILOR motors, the torque that the motor can produce continuously at rated speed (3000 rpm for most MSS Series motors) exceeds the stall torque rating of the motor. The continuous torque rating (T) is the value used for sizing motors once the RMS torque requirement has been determined.

Acceleration torques to 10X rated torque can be obtained. The S3 curves for each motor should be consulted to ascertain time duration vs duty cycle for peak torques.

## Performance Curves

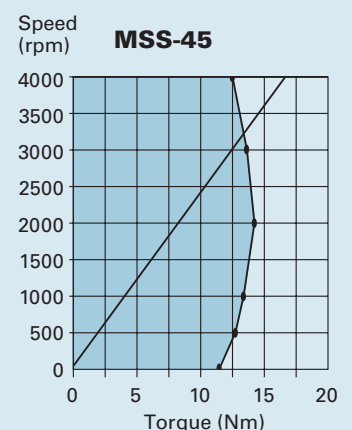
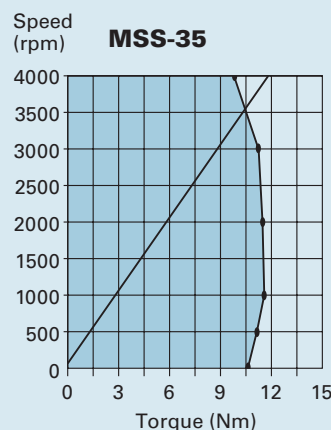
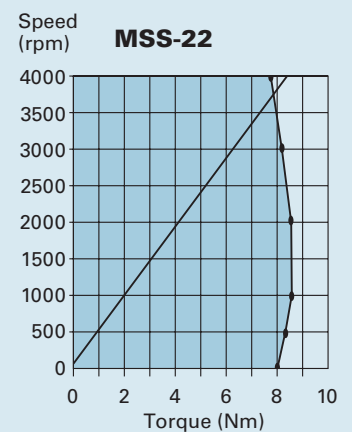
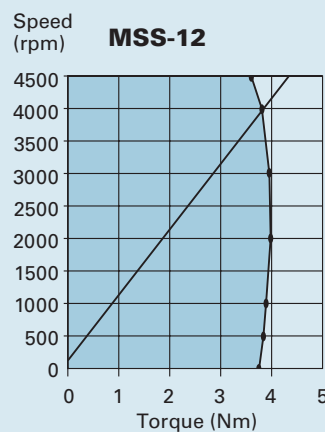
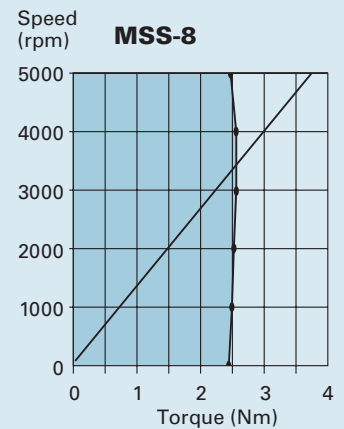
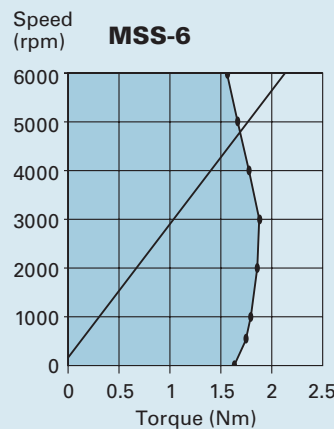
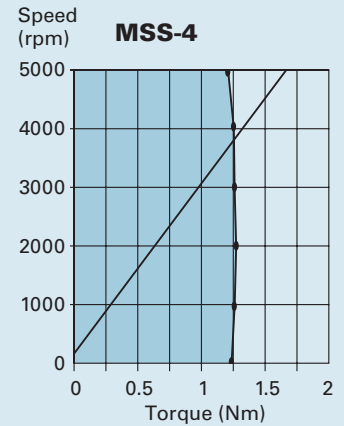
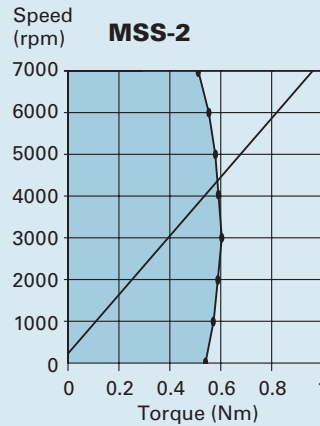

# Optional Accessories

## MSS Encoder Kit (no encoder)

	l
<b>MSS-2</b>	235
<b>MSS-4</b>	233
<b>MSS-6</b>	233
<b>MSS-8</b>	243.5
<b>MSS-12</b>	237.5
<b>MSS-22</b>	265.5
<b>MSS-35</b>	291
<b>MSS-45</b>	291

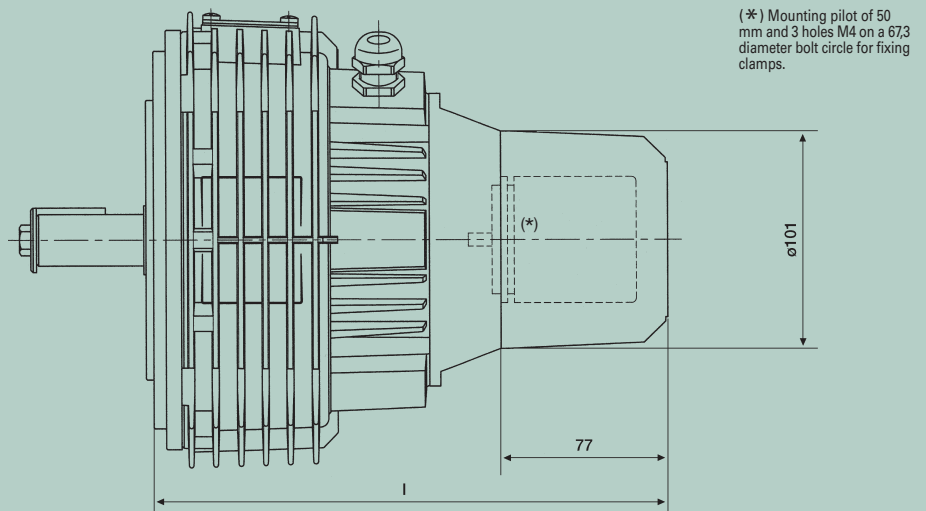

## MA Encoder Kit (no encoder)

	A
<b>MA-6</b>	237.5
<b>MA-10</b>	237.5
<b>MA-20</b>	252.5
<b>MA-30</b>	261.5
<b>MA-45</b>	274
<b>MA-55</b>	274

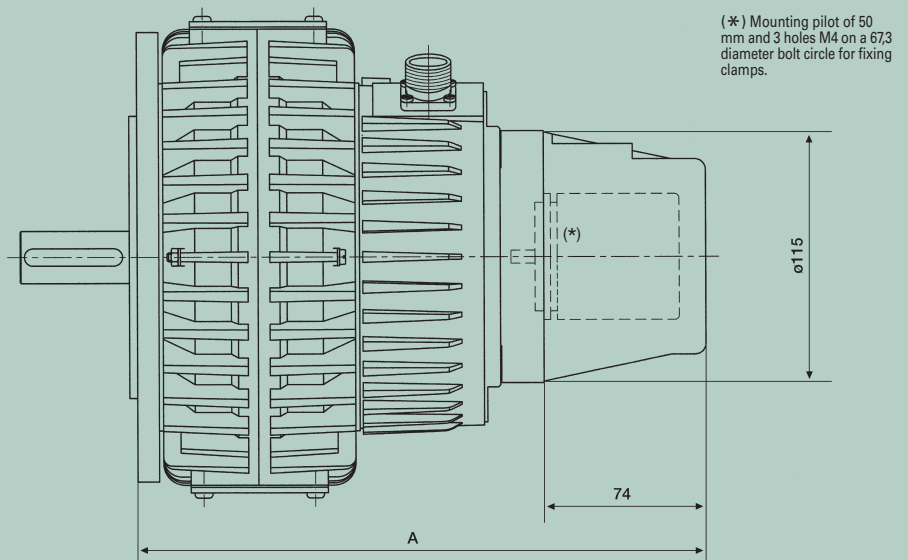

## BL 110/140 Encoder Kit (no encoder)

	A
<b>BL-111</b>	282
<b>BL-112</b>	307
<b>BL-113</b>	332
<b>BL-114</b>	357
<b>BL-115</b>	382
<b>BL-141</b>	346
<b>BL-142</b>	367
<b>BL-143</b>	411
<b>BL-144</b>	453

