

SKF

SKF spherical roller bearings - setting a new standard for performance and reliability



Contents

Made by SKF® stands for excellence. It symbolises our consistent endeavour to achieve total quality in everything we do. For those who use our products. “Made by SKF” implies three main benefits.

Reliability – thanks to modern, efficient products, based on our worldwide application know-how, optimised materials, forward-looking designs and the most advanced production techniques.

Cost effectiveness – resulting from the favourable ratio between our product quality plus service facilities, and the purchase price of the product.

Market lead – which you can achieve by taking advantage of our products and services. Increased operating time and reduced down-time, as well as improved output and product quality are the key to a successful partnership.



1 Product information	3
Economical and robust	3
Why spherical roller bearings?	3
Why SKF spherical roller bearings?	4
A complete bearing range	6
SKF spherical roller bearings – leading in design ...	8
Standard bearings: a unique combination of design features	8
Setting new standards: the SKF Explorer	9
Sealed SKF spherical roller bearings – for demanding environments	10
SKF Explorer – the new performance class for spherical roller bearings	12
Efficient in all industrial segments	14
Where maintenance can be a nightmare	14
Downsizing – more than just size	15
Trouble-Free Operation – the SKF concept for cost saving	16
2 Recommendations	18
Selection of bearing size	18
Bearing life	18
Standard and Explorer – a comparison	19
Minimum load	20
Required static load rating	20
Application of bearings	21
Conventional bearing arrangements	21
The new self-aligning bearing system	22
Radial location of bearings	22
Axial location of bearings	23
Design of associated components	23
Mounting and dismantling	24
Bearing storage	24
Mounting	24
Dismounting	27
Lubrication and maintenance	28
Oil lubrication	28
Grease lubrication	28
Maintenance	31
3 Product data	32
Bearing data – general	32
Supplementary designations	35
Bearing tables	36
Open spherical roller bearings	36
Sealed spherical roller bearings	54
Related SKF products	58
The SKF Group – a worldwide organisation	63

Economical and robust

Why spherical roller bearings?

Spherical roller bearings offer an attractive combination of design features, which are making them irreplaceable in many demanding applications.

- **Self-aligning**
Spherical roller bearings allow misalignment between shaft and housing without increase of friction and without reduction of bearing life.
- **Very high load carrying capacity**
Optimum layout inside available cross-section provides maximum radial and axial load carrying capacity.
- **Robust**
Insensitive to misalignment caused by shaft or housing deflection due to heavy load.
- **Easily fitted for loads in all directions**
The bearings are non-separable and ready to install using a number of mounting methods.
- **Easy bearing application**
The favourable design characteristics and mounting enable for a more efficient and compact machine design.

Spherical roller bearings with integral seals offer additional benefits.

- **Protection against contamination**
Sealed spherical roller bearings are especially suited for bearing positions where, because of limited space or for cost reasons, effective external seals cannot be provided.
- **Grease retention**
Contact seals on both sides of the bearing retain the factory filled grease where it is required: inside the bearing.

- **Minimum maintenance requirements**

Under normal operating conditions, sealed spherical roller bearings are maintenance free, keeping service costs and grease consumption low.



Customer benefits

Page 18

Page 32

Why SKF spherical roller bearings?

SKF bearings are developed for customer satisfaction. The best confirmation of the total quality of SKF spherical roller bearings is their success on the market. There are twice as many SKF spherical roller bearings in service as those of any other bearing manufacturer.

This is not just by chance: SKF spherical roller bearings are well-proven in the field and undergo continuous development to provide improved performance. The most recent example has been the introduction of the Explorer bearings, which opened up new application horizons, and the sealed bearings in standard and Explorer versions.

The use of SKF spherical roller bearings implies several benefits.

Application efficiencies

SKF spherical roller bearings have a very high load carrying capacity in the radial and axial directions. Bearing applications become increasingly cost effective due to

- long service life and
- compact arrangements.

Reduced operating costs

The optimised and robust internal design of the SKF spherical roller bearings minimises friction and heat, and by this, lubricant consumption. In service, this reduces costs due to

- less machine downtime,
- minimised maintenance requirements and
- high reliability.

Seals integration

Under normal operating conditions, sealed SKF spherical roller bearings are greased for life and make external seals unnecessary, creating additional benefits:

- simplified bearing arrangements;
- no relubrication.

Standard solution

Many bearing applications previously fitted with expensive special bearings can now be equipped with SKF spherical roller bearings. Because of the global availability of SKF spherical roller bearings, spare parts are much easier to get.

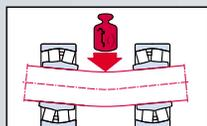
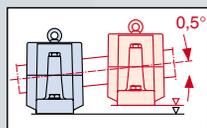
**Rugged****Tolerant to alignment errors****Resistant to elevated temperatures**

Customer benefits

Page 18

Page 32

Customer satisfaction

Equipment owners will be impressed by the low operating costs in combination with high reliability contributed by SKF spherical roller bearings. Not only are costs reduced, but with sealed versions environmental resources are spared.



SKF bearings:
always the best choice, when robustness and reliability matter

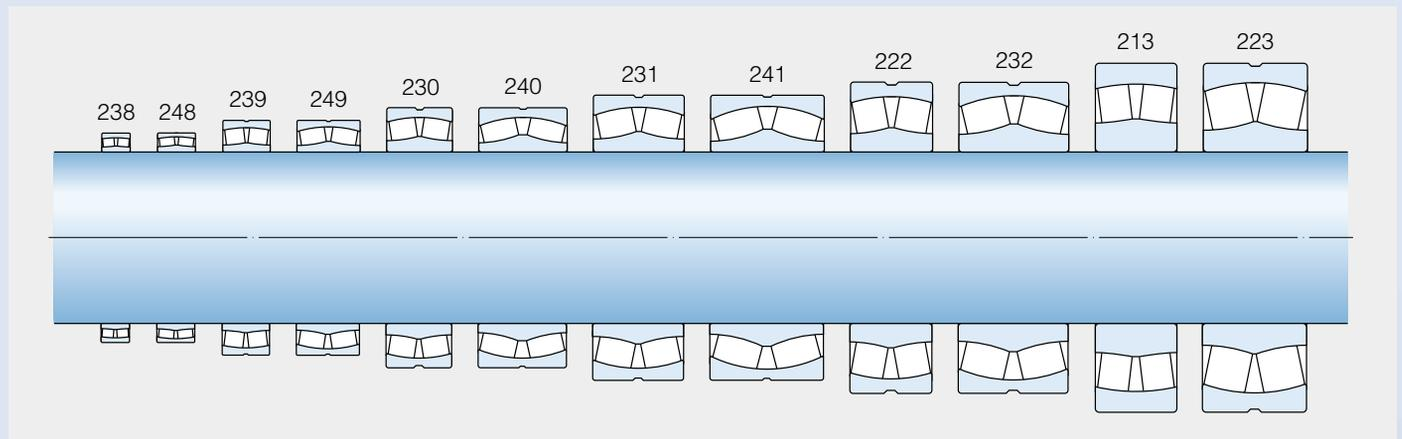

**Bearing series**

A complete bearing range

The range of open and sealed SKF spherical roller bearings covers all series currently in demand. Taking availability into account, this constitutes the most complete range on the market.

Narrow low-section bearings have better speed, space and weight characteristics. Wide high-section bearings have higher load carrying capacity.

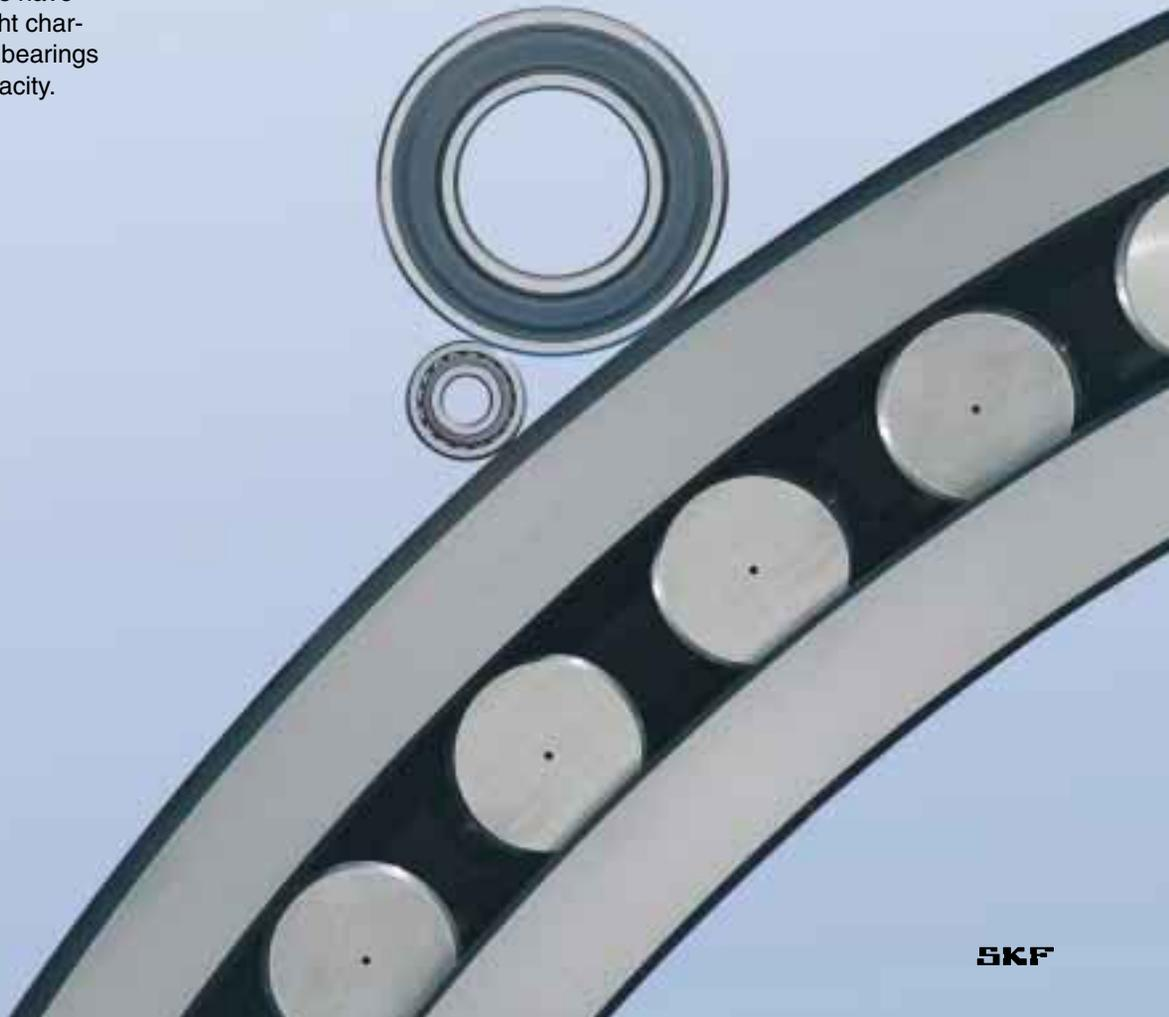

Product range

Page 18

Page 32

SKF spherical roller bearings without seals

The open bearings are available in sizes from 20 to 1 800 mm bore diameter and with cylindrical or tapered bore to suit all types of mounting methods. To facilitate efficient lubrication, most bearings are provided with an annular groove and three lubrication holes in the outer ring.

The bearings are available in a wide range of series designed to satisfy the following selection criteria:

- load carrying capacity;
- combination of radial and axial loads;
- rotational speed;
- space in the application.

Sealed SKF spherical roller bearings

The SKF range of sealed spherical roller bearings comprises bearings with cylindrical bore for shaft diameters of 35 to 220 mm and bearings with tapered bore for shaft diameters of 40 to 90 mm in the seven most frequently used bearing series. Further sizes can be produced to special order.

The seals have been specially developed for spherical roller bearings and effectively prevent contamination from entering the rolling contact area. This is not only true in operation, but also during bearing installation, resulting in long service life.

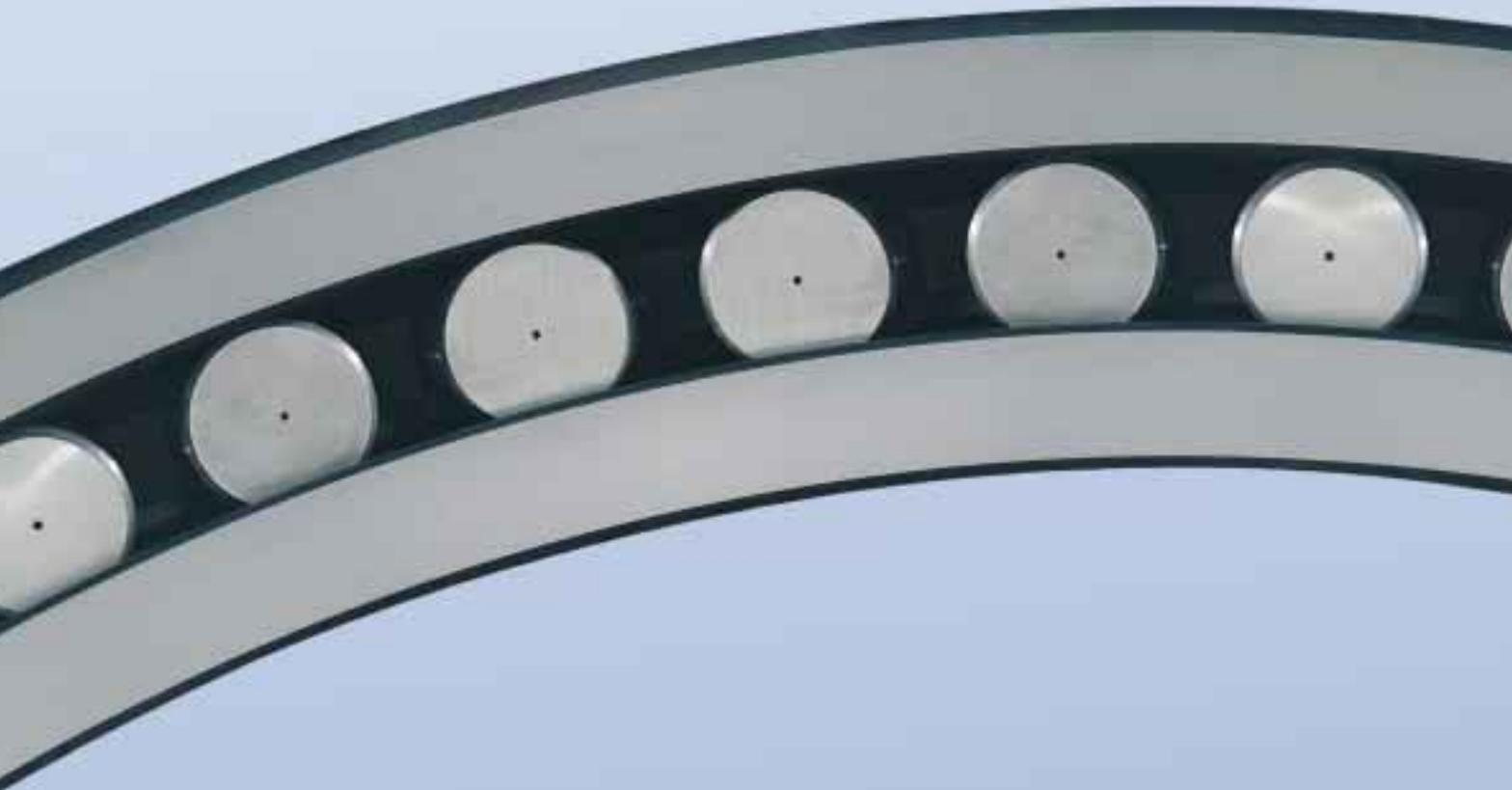

SKF spherical roller bearings – leading in design

Standard bearings: a unique combination of design features

All SKF spherical roller bearings have features in common which are unique in the market:

- symmetrical rollers
- special roller profile
- self-guiding rollers – an SKF patent
- floating guide ring between the two rows of rollers
- bearing components dimensionally stabilised for high temperatures
- metallic cages

To facilitate efficient bearing lubrication SKF standard spherical roller bearings are provided with three lubrication holes in the outer ring, mostly in combination with an annular groove. Depending on size and series, standard SKF spherical roller bearings are basically made in three different designs:

- E design
- CC design
- CA design



E design

The bearings of this design have symmetrical rollers, two hardened window-type steel cages centred on the inner ring, a flangeless inner ring and a floating guide ring between the two roller rows.

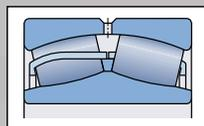

CC design

With symmetrical rollers, two window-type steel cages which are inner ring centred via a floating guide ring between the two roller rows.

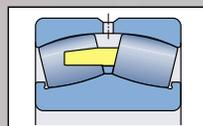

CA design

With symmetrical rollers. The inner ring centred guide ring centres the one piece, double pronged machined cage of brass or steel. The inner ring has retaining flanges.



Durable cage design

Steel and brass cages are strong as well as tolerant to high temperatures and all lubricants. Small and medium size bearings have window-type steel cages, larger sizes have machined double pronged brass or steel cages.



E design



CC design

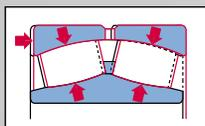

Very high load carrying capacity
The symmetrical rollers self-adjust, providing an even load distribution along the roller length. This gives very high load carrying capacity under all load combinations.

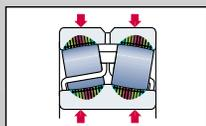

No edge stresses
The special roller profile minimises the risk of edge stresses.

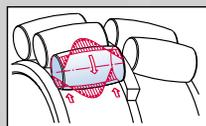

Reduced friction and minimum heat generation
Self-guiding rollers – an SKF patent – mean reduced friction and minimum heat generation.



Excellent performance at high temperatures
High-strength, dimensionally stable bearing rings minimise the risk of ring breakage and also allow good performance at high temperatures.

Setting new standards: the SKF Explorer

The unique SKF spherical roller bearing designs were the starting points for further development of materials and manufacturing processes. The Explorer spherical roller bearings are the result of very skilled and intensive fine tuning processes, which, taken all together constitute a new performance level for spherical roller bearings.

- **Steel**
New, ultra-clean for longer life at higher loads.
- **Heat treatment**
New procedures significantly improve wear resistance.
- **Manufacturing**
Refined processes allow the production of smoother running bearings with improved lubrication.
- **Internal geometry**
A fine-tuned micro-geometry of the rolling contacts gives better stress distribution.

Explorer bearings give more performance for the same size as explained in more detail from **page 12** onwards.



CA design

Sealed SKF spherical roller bearings – for demanding environments

Sealed SKF spherical roller bearings are designed to fulfil high demands on sealing efficiency and operational reliability under difficult environmental conditions. The seals were developed using computer simulation, making full usage of the vast expertise within the SKF Group. They have been extensively tested both in the laboratory and in the field and have proved their reliable performance and efficiency.

SKF sealed spherical roller bearings include double-lip, sheet steel reinforced seals made of

- nitrile rubber (NBR)
- hydrogenated nitrile rubber (HNBR)
- fluoro rubber (FPM)

and a grease fill which is appropriate to the operating conditions.

This forms a ready-to-mount and lubricated-for-life bearing with long service life and normally the same space requirements as a standard open bearing. The advantages include a simplification of the bearing arrangement, as well as the option of down-

sizing. Facilities for relubrication are normally not required, and there are no more costs for purchasing, applying and disposing of bearing greases.

Temperature limits

Sealed SKF spherical roller bearings are suitable for normal operating temperatures up to 110 °C (230 °F). Bearings for higher operating temperatures can be produced upon request. In these cases, the grease and seal material must be chosen accordingly. Other operating conditions such as the speed may need to be considered as well. Please contact the SKF application engineering service for further advice.



Contamination resistance

Due to the efficiency of the integral seals, additional external seals are normally not required. Generally compact bearing arrangements can be produced in most cases. However, if the environmental conditions are harsh, external seals should be employed (→ fig 1).

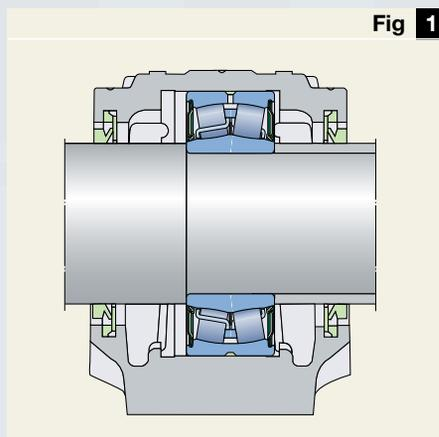

A sealed spherical roller bearing in an SNL plummer block housing

Warning for fluoro rubber (FPM) seals

FPM is very stable and harmless in normal operating conditions – up to 200 °C (392 °F). However, if exposed to extreme temperatures above 300 °C (572 °F), e.g. fire or the flame of a cutting torch, fluoro rubber emits dangerous toxic vapours. Once overheated the fluoro rubber will remain dangerous to handle even when cooled. Please contact SKF for complete safety instructions. See also SKF catalog 4006 “CR seals” for further information.

Rule of thumb

Sealed bearings do not need relubrication when the temperatures do not exceed 70 °C (158 °F) and speed are not more than 50 % of the speed rating listed in the product tables. More precise information is given in the section “Lubrication and maintenance” on page 28.

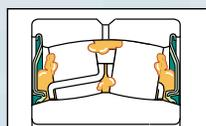

Well lubricated
Bearings for normal operating temperatures and speeds are lubricated with the SKF lithium base grease LGEP 2 with excellent rust inhibiting properties.



Well protected
The bearings have a sheet steel reinforced double-lip seal at each side. Seals can be made of nitrile rubber (NBR), hydrogenated nitrile rubber (HNBR) or fluoro rubber (FPM).



Solid contaminants excluded
Eliminate dirt in the bearing, which creates indentations in both raceways and rollers and causes early failure due to flaking. The best and simplest method to do this is to use SKF sealed spherical roller bearings. The seals offer protection for the bearing interior during handling and mounting.

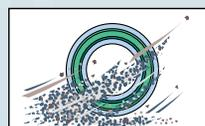

Always reliable
The bearings are filled with a high-quality grease, which is particularly suitable for SKF spherical roller bearings. Integral seals contribute to the efficient lubrication by keeping the lubricant in position inside the bearing.



Moisture cannot enter
Adequate seals keep water out of the bearing, which otherwise would cause corrosion and considerable damage to the raceways, leading to noise and early failure. The improved seals are endorsed by the rust inhibiting properties of the lubricant.

SKF Explorer – the new performance class for spherical roller bearings

Having invented the spherical roller bearing some eighty years ago, SKF has been the leading manufacturer of these bearings ever since.

Now our specialists in all different disciplines have combined their experience and know-how into one large step forward in bearing technology. And we are proud of having made tomorrow's bearing technology available for our customers today. The Explorer bearings represents a significant breakthrough in performance. By studying the interrelationship between each bearing component, SKF scientists were able to maximize the effects of lubrication and minimize the effects of friction, wear, and contamination.

The Explorer design is the result of years of intensive research by an international team of SKF scientists and engineers. It incorporates a number of improvements including:

The new material

The new steel used in SKF Explorer bearings is extraordinarily clean and homogeneous. It forms a perfect structure which does not generate stress peaks under load.

The new heat treatment

Together with a refined heat treatment process, the new steel significantly improves the SKF Explorer bearings wear resistance. It does this while retaining the temperature resistance and toughness of the bearings.

The new manufacturing processes

Improved manufacturing processes has enabled the tightening of the tolerances for all essential bearing features. To achieve good bearing performance, the surface texture has been refined to maintain an optimum oil film between the contacting surfaces.

The new bearing knowledge

Sophisticated in-house software has enabled SKF design engineers to study internal bearing dynamics to an extent not possible previously. This led the way to design refinements, which, implemented in the Explorer bearings, allowed further optimisation of the rolling element/raceway contacts.



New performance class

Page 18

Page 32

The result: longer bearing life

All these improvements contribute to a significant increase in bearing service life and reliability. This can best be shown through calculation using the SKF Life Method. The properties of SKF Explorer spherical roller bearings are taken into consideration by

- increased basic dynamic load ratings and
- an increased life adjustment factor a_{SKF} .

Availability

The popular small and medium size spherical roller bearings in the series 213, 222, 223, 230, 231, 240 and 241 are available as Explorer bearings. The range is being extended in these bearings series as well as in other series.

In the product table, the Explorer bearing designations are printed in blue.

Product designations

The Explorer bearings retain the designations of the earlier standard bearings, e.g. 22218 E or BS2-2210 C-2CS. However, each bearing and its box is marked with the name EXPLORER, so that there can be no confusion.

Existing machine

Switching to Explorer bearings give

- several times the service life previously achieved,
- more machine uptime,
- higher safety factor,
- an appreciable reduction of machine cycle cost

and, therefore, added value.

New machine with same power

Explorer makes it possible to use a smaller bearing size which allows

- more compact machines,
- higher speeds,
 - smoother and quieter running,
 - less lubricant usage,
 - reduced friction,

and will create added value.

What Explorer does for your machine

Existing machine with increased power

Same size Explorer bearings allow power increases of 15 to 25 % with

- same service life,
 - same machine uptime,
 - same machine design,
- and higher added value.

New machine with same or increased power

The higher carrying capacity of Explorer bearings allows the use of a lighter series with same outside diameter and increased bore diameter, so that

- a stronger, or even hollow shaft can be used,
 - the total design can be stiffer and also cheaper,
 - system life is increased due to higher stiffness,
- and machine cycle cost is significantly reduced.

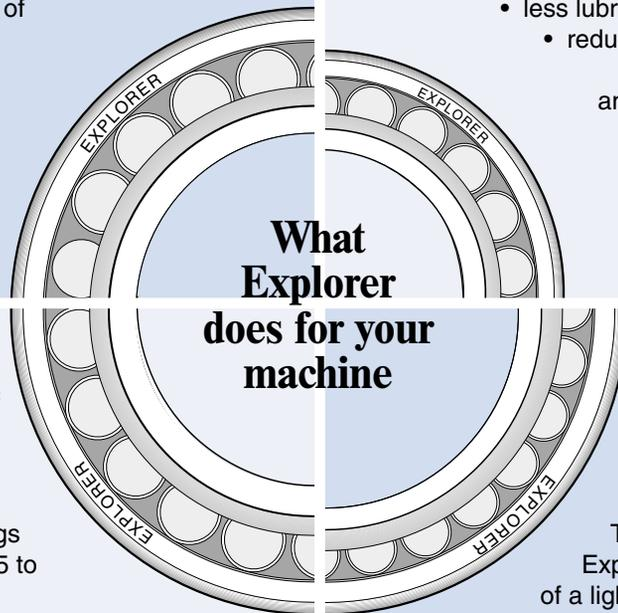

Efficient in all industrial segments

Industrial segments

- Metallurgical
- Mining & construction
- Pulp & paper
- Fluid machinery
- Materials handling
- Industrial gearboxes
- Textile industry
- Railways

Requirements

- Long service life
- High load carrying capacity
- Compact arrangements
- Tolerant of misalignment
- Minimum maintenance
- Reduced operation costs
- No unplanned stoppages
- Environmental welfare
- High availability
- Technical support

Solution



Long service life, high reliability, limited maintenance and the ability to design compact arrangements have made SKF spherical roller bearings indispensable in many industries. In addition to the industries listed above SKF spherical roller bearings are also used in bridges, dam gates, electric motors, generators, plastic calenders, extruders, printing machines, robots and many other applications.

Because end users are recognizing that high quality bearings deliver an excellent return on investment, SKF spherical roller bearings are becoming the preferred choice in new applications.

Where maintenance can be a nightmare

To get to the top is always a challenge, particularly if the goal is the top of ski-lift masts in mid winter when it is 30 degrees below zero and the bearings have to be relubricated. If operational reliability is to be achieved, then it has to be done. Regular relubrication is a must if the bearings are to be kept from rusting because of condensation. In addition safety considerations call for regular inspections – a dangerous job high up in mountainous terrain and under difficult weather conditions.

The introduction of SKF sealed spherical roller bearings has made all the dif-

ference. It is now only necessary to perform maintenance once a season – before starting operation. The highly efficient seals reliably exclude condensation so that corrosion is no longer a problem. It has also been possible to simplify the arrangement, saving space and costs – as well as making handling and installation easier.



Downsizing - more than just size

A typical application for spherical roller bearings is the winch of a traversing industrial lift. In this application the load, bending and deformation all call for rugged bearings that can function properly even under misalignment.

Open spherical bearing arrangements provided good service, but were too bulky and complicated to be considered completely satisfactory.

As a result, the open bearings were replaced with SKF sealed spherical roller bearings eliminating the need for the external seals and covers.

This obviously saved space and also meant that the bearings could be positioned 40 % closer to the drum, thus reducing the stress on the journals. In fact, it was possible to reduce the journal diameter by 20 % and use smaller bearings.

The new compact bearing arrangement requires much less maintenance and there is no loss of load lifting capacity. The result has been a 50 % savings of the total cost of the original bearing arrangement.



Trouble-Free Operation – the SKF concept for cost saving

The bearings in a machine can be compared to the heart of a human being. If the bearing comes to a standstill, so does the machine.

Just as a doctor listens to the heart of a patient, so it is possible to listen to the bearings in order to judge the condition of the machine. It is possible to determine whether the bearing is in danger of failing prematurely because of faulty mounting, poor lubrication or other causes.

If the bearings are neglected the result will be higher costs, unnecessary stoppages and, in the worst case, damage to other components of the machine. However, if the bearings are given the attention they deserve, not only will productivity be increased, but costs for maintenance, purchasing and storage will be reduced.

Why is SKF so certain of this? Because, SKF bearings, given ideal operating conditions, can live almost for ever.



Trouble-Free Operation

All that is needed is a partnership with SKF for Trouble-Free Operation (TFO™). This includes everything you need to eliminate downtime from one reliable source:

- plant maintenance assessment
- reliability systems – local and via satellite
- predictive and preventive maintenance programs
- root cause failure analysis
- lubrication and filtration management
- equipment maintenance and monitoring – fans, pumps, gear boxes and spindles
- precision balancing
- precision alignment
- productivity management process
- applications-specific training
- technology upgrades
- repair services

There is no single TFO program from SKF, because it is defined in terms of a company's own particular needs and application challenges. Whatever the choice, it will be a win-win situation.

More information can be obtained from the nearest SKF office or authorised dealer.



SKF service engineer on site

Expert advice from the SKF application engineering service



SKF mounting and dismounting tools



Practical SKF seminars cover all there is to know about mounting and maintaining rolling bearings



Selection of bearing size

Bearing life

The life-extending improvements embodied in SKF Explorer spherical roller bearings can best be understood using the SKF Life Method. This calculation method constitutes an extension of the fatigue life theory developed by Lundberg and Palmgren and is better able to predict bearing life. The Life Method was first presented as the SKF New Life Theory in the SKF General Catalogue 4000 in 1989. For roller bearings

$$L_{naa} = a_1 a_{SKF} L_{10}$$

or

$$L_{naa} = a_1 a_{SKF} \left(\frac{C}{P}\right)^{10/3}$$

If the speed is constant, it is often preferable to calculate the life expressed in operating hours using

$$L_{naah} = a_1 a_{SKF} \frac{1\,000\,000}{60 n} \left(\frac{C}{P}\right)^{10/3}$$

where

L_{naa} = the adjusted rating life according to the SKF Life Method, million revolutions

L_{naah} = the adjusted rating life according to the SKF Life Method, operating hours

L_{10} = basic rating life, million revolutions

a_1 = life adjustment factor for reliability (→ **Table 1**)

a_{SKF} = life adjustment factor based on SKF Life Method (→ **Diagram 1**)

C = basic dynamic load rating, kN

P = equivalent dynamic bearing load, kN

n = rotational speed, r/min

a_{SKF} factor

The a_{SKF} factor represents a very complex relationship between various influencing factors including contamination and lubrication. Lubrication conditions are expressed by the viscosity ratio κ . Values of a_{SKF} can be obtained from **Diagram 1** for different values of $\eta_c (P_u/P)$ and κ .

For standard spherical roller bearings, the values in black on the x axis should be used and for Explorer bearings the values in blue on the x axis. In fact, for Explorer spherical roller bearings it has been found appropriate to multiply $\eta_c (P_u/P)$ by 1,4 as an expression of the life extending refinements of these bearings, and the blue values correspond to this.

Diagram 1 has been drawn up for a safety factor commonly used in fatigue life considerations and is valid for lubricants without EP additives. If a lubricant containing such additives is used, reference should be made to the SKF General Catalogue or the SKF Interactive Engineering Catalogue on CD-ROM or the Internet (www.skf.com).

Equivalent dynamic bearing load

The equivalent dynamic bearing load for spherical roller bearings can be obtained from

$$P = F_r + Y_1 F_a \quad \text{when } F_a/F_r \leq e$$

$$P = 0,67 F_r + Y_2 F_a \quad \text{when } F_a/F_r > e$$

where

P = equivalent dynamic bearing load, kN

F_r = actual radial bearing load, kN

F_a = actual axial bearing load, kN

Y_1, Y_2 = axial load factors for the bearings

e = calculation factor

Appropriate values of the factors e , Y_1 and Y_2 will be found in the bearing tables for each individual bearing.

Life adjustment factor a_1

Table 1

Reliability %	Factor a_1
90	1
95	0,62
96	0,53
97	0,44
98	0,33
99	0,21

Standard and Explorer – a comparison

The performance enhancements incorporated into the SKF Explorer spherical roller bearings can best be demonstrated by a life calculation comparison for the bearing 22218 E in its earlier standard and its new Explorer version.

For the same operating conditions the life of

- the previous standard 22218 E with
 - a basic dynamic load rating $C = 282$ kN, and
 - a fatigue load limit $P_u = 39$ kN, and
- the Explorer bearing 22218 E with
 - a basic dynamic load rating $C = 325$ kN, and
 - a fatigue load limit $P_u = 39$ kN

are calculated.

The operating conditions are:

- equivalent dynamic bearing load $P = 28,2$ kN
- viscosity ratio $\kappa = 2$
- contamination factor $\eta_c = 0,4$.

The lives of the two bearings are then calculated.

Earlier standard bearing

For $\eta_c (P_u/P) = 0,4 \times 39/28,2 = 0,55$ using the black values on the x axis in **Diagram 1** and $\kappa = 2$

$$a_{SKF} = 3,7$$

so that the life becomes

$$L_{10aa} = a_{SKF} (C/P)^{10/3} = 3,7 \times (282/28,2)^{10/3}$$

$$L_{10aa} = 7\,970 \text{ million revolutions.}$$

Explorer bearing

For $\eta_c (P_u/P) = 0,4 \times 39/28,2 = 0,55$ using the blue values on the x axis in **Diagram 1** and $\kappa = 2$

Diagram 1 and $\kappa = 2$

$$a_{SKF} = 7,1$$

so that the life becomes

$$L_{10aa} = a_{SKF} (C/P)^{10/3} = 7,1 \times (325/28,2)^{10/3}$$

$$L_{10aa} = 24\,500 \text{ million revolutions.}$$

In this case, the Explorer bearing has a life compared with that of the previous standard bearing, which is $24\,500/7\,970 = 3,07$ or just over three times longer.

Factor a_{SKF} for spherical roller bearings

Diagram 1

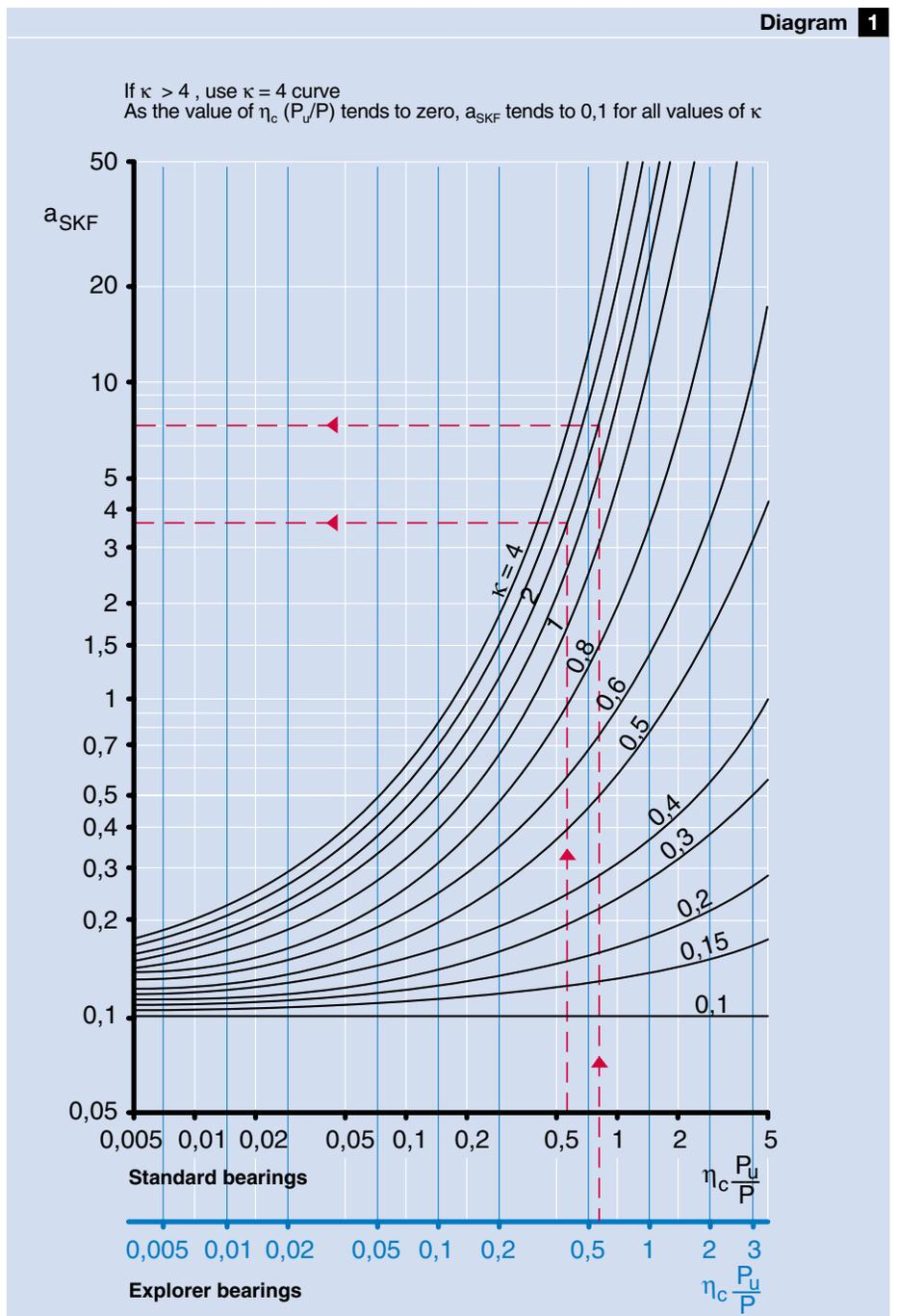

Minimum load

In order to provide optimum performance, spherical roller bearings must always be subjected to a given minimum load, especially if they operate at high speeds or are subjected to high accelerations or rapid changes in the direction of load. Under such conditions the inertia forces of the rollers and cage, and the friction in the lubricant, can have a detrimental influence on rolling conditions in the bearing and may cause damage due to sliding movements between the rollers and raceways.

The requisite minimum load to be applied to SKF Explorer spherical roller bearings can be estimated from

$$F_{rm} = 0,017 C - Y_0 F_a$$

and for standard spherical roller bearings from

$$F_{rm} = 0,02 C - Y_0 F_a$$

where

F_{rm} = minimum radial load, kN

C = basic dynamic load rating, kN

F_a = actual axial bearing load, kN

Y_0 = axial load factor of the bearing

The values for C and Y_0 will be found in the bearing tables for each individual bearing.

When starting up at low temperatures or when the lubricant is highly viscous, even greater loads may be required. The weights of the components supported by the bearing, together with the external forces, often exceed the requisite minimum load. If this is not the case, the bearing must be subjected to an additional radial load. It is advisable to contact SKF when problems with minimum load occur.

Guideline values for the static safety factor s_0

Required static load rating

The requisite basic load rating C_0 can be determined from

$$C_0 = s_0 P_0$$

where

C_0 = static load rating, kN

s_0 = static safety factor

P_0 = equivalent static bearing load, kN

Guideline values based on experience are given in **Table 2** for the static safety factor s_0 for various types of operation and requirements regarding smooth running.

The equivalent static bearing load for spherical roller bearings can be obtained from

$$P_0 = F_r + Y_0 F_a$$

where

P_0 = equivalent static bearing load, kN

F_r = actual radial bearing load, kN

F_a = actual axial bearing load, kN

Y_0 = axial load factor of the bearing

The appropriate value of the factor Y_0 will be found in the bearing tables for each individual bearing.

Are you still doing these calculations by hand?

The CD-ROM "SKF Interactive Engineering Catalogue" includes all the equations mentioned in this brochure and the underlying software enables them to be calculated at the click of a mouse. Visit our site on the Internet "www.skf.com"

Table 2

Type of operation	Rotating bearings			Non rotating bearings
	Requirements unimportant	Requirements normal	Requirements regarding quiet running high	
Smooth, vibration-free	1	1,5	3	0,8
Normal	1	1,5	3,5	1
Pronounced shock loads	≥ 2,5	≥ 3	≥ 4	≥ 2

Application of bearings

Conventional bearing arrangements

Conventional self-aligning bearing arrangements using two spherical roller bearings (→ **fig 1**) – one applied as a locating, the other as a non-locating bearing – are the basis of many industrial bearing arrangements. This is a simple robust arrangement capable of withstanding high radial as well as thrust loads, whilst easily accommodating misalignments.

The non-locating bearing must be able to slide axially, usually inside the housing, to accommodate shaft expansion or contraction. To achieve this movement, one of the bearing rings must be mounted with a loose fit and axial space provided for movement.

Under certain loading conditions, however, this bearing arrangement may not be suitable. The ring with a loose fit can creep and damage the housing. It can also result in accelerated wear and increased vibration, additional maintenance and repair costs. It also means that the shaft is supported less rigidly in the radial direction. In these situations, SKF recommends a new self-aligning system.

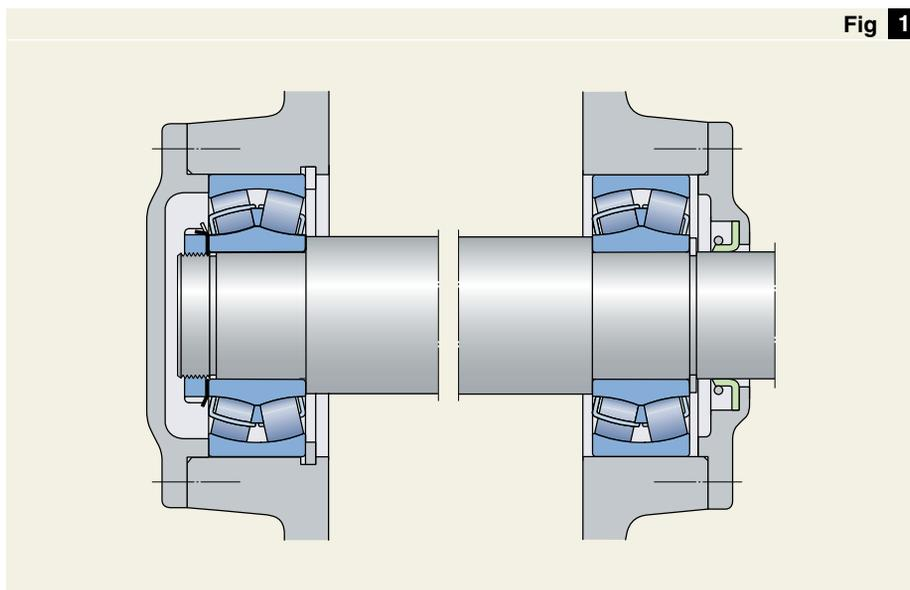

Fig 1

Conventional spherical roller bearing arrangement with locating (left) and non-locating bearing (right)

The new self-aligning bearing system

The new self-aligning bearing system consists of a spherical roller bearing as the locating and a CARB® toroidal roller bearing as the non-locating bearing (→ fig 2).

This bearing system accommodates misalignment as well as axial movement without generating additional axial forces caused by the friction between the outer ring and housing. Due to the ideal co-operation of both bearings the real load situation is always as predicted.

The advantages of spherical roller bearings and CARB bearings are fully utilised in this bearing system, allowing the performance expected and needed by designers today.

The new self-aligning system enhances reliability and performance. Producers as well as users of machines have clearly reduced costs due to simpler design and increased productivity.

More information will be found in the SKF brochure 4417 "Self-aligning bearing systems" .

Radial location of bearings

If the load carrying ability of a bearing is to be fully utilised, its rings must be evenly supported around the circumference and across the whole width of the raceway. This support must be firm and even and can be provided by a cylindrical or tapered seating.

Sufficient support, as well as good radial location of the bearing, generally requires a tight fit between the bearing rings and the surrounding components. However, if easy mounting and dismounting is required, or for the one ring of non-locating bearings, a tight fit cannot be applied.

Further information on selection of fits and accuracy of the bearings seatings will be found in the SKF General Catalogue or CD-ROM "SKF Interactive Engineering Catalogue".

Fig 2

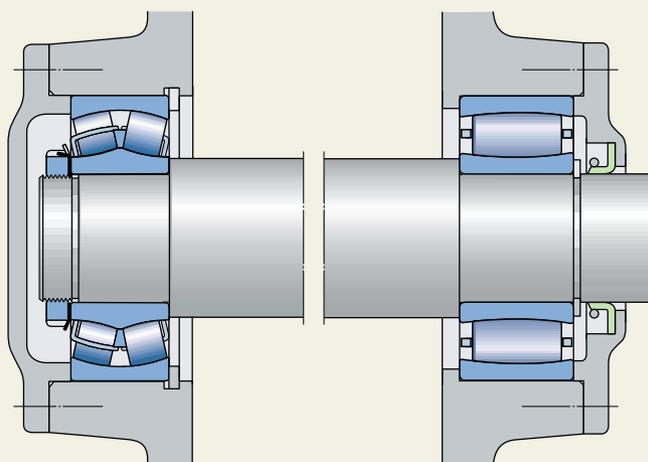

Self-aligning bearing system using a CARB bearing as the non-locating bearing

Axial location of bearings

An interference fit alone is generally inadequate for the axial location of a spherical roller bearing ring. As a rule, some suitable means of axially securing the ring is needed. Both rings of a locating bearing should be axially secured at both sides. For non-locating bearings, on the other hand, it is sufficient if the ring having the tighter fit – usually the inner ring – is axially secured; the other ring must be free to move axially with respect to its seating (→ fig 1 on page 21).

Bearing rings having an interference fit are generally mounted so that the ring abuts a shoulder on the shaft or in the housing at one side. At the opposite side, inner rings are normally secured by a snap ring, shaft nut or an end plate attached to the shaft end. Outer rings are usually retained by the housing end cover (→ fig 1 on page 21).

The dimensions of the shaft and housing shoulders adjacent to the bearing must provide sufficient support for the bearing rings, without contact between the rotating parts of the bearing and a stationary component. To ensure this, appropriate abutment dimensions are quoted for each individual bearing listed in the product tables.

When using a shaft nut to locate a sealed bearing, insert an intermediate ring between the bearing and the locking washer and, probably, to extend the threaded portion of the shaft accordingly (→ fig 3).

Design of associated components

For arrangements with large spherical roller bearings it is often necessary to make design provisions to enable the bearings to be mounted or dismounted easily. For example, withdrawal tools can be applied to dismount bearings, if appropriate slots are machined in the shaft and housing shoulders, or if threaded holes are provided in the housing shoulders.

If the oil injection method is to be used to mount and dismount bearings on tapered journals (→ fig 4) or to dismount bearings from cylindrical seatings (→ fig 5), it is necessary to provide oil supply ducts in the journal and grooves in the seating. Recommendations are given in the SKF publication 4100 “SKF Bearing Maintenance Handbook” or CD-ROM “SKF Interactive Engineering Catalogue”.

An intermediate ring between the bearing and lock washer (of the nut) protects the seal

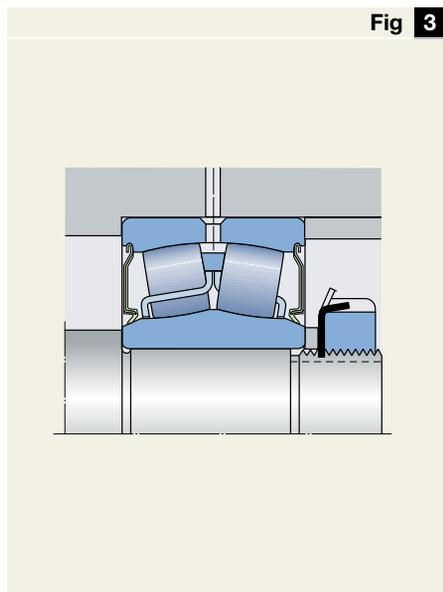

Spherical roller bearing of CAK design on a tapered journal with oil supply ducts and grooves

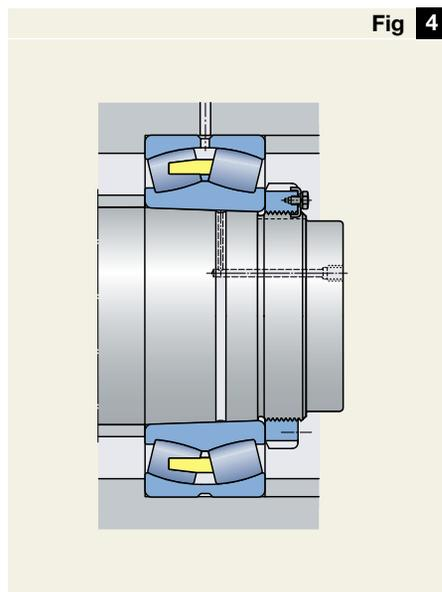

Spherical roller bearing of CA design on a cylindrical seating with oil supply ducts and grooves

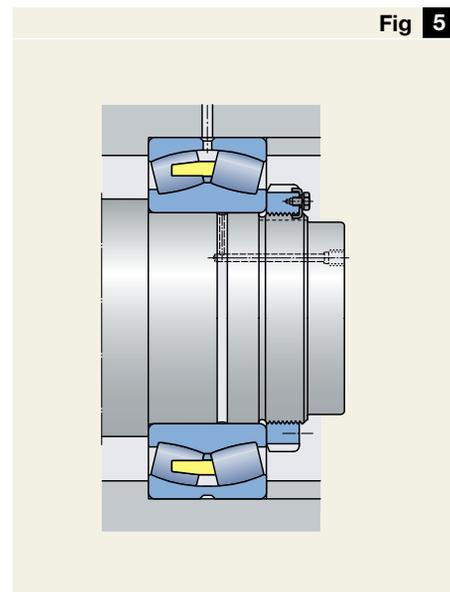

Mounting and dismounting

Bearing storage

Before leaving the factory, SKF spherical roller bearings are treated with a corrosion inhibitor. They can be stored in their unopened original packages for up to five years (three years for sealed bearings), provided the relative humidity in the store does not exceed 60 % (→ **fig 1**).

To avoid the risk of contamination and corrosion, the original packages should not be opened until immediately before mounting the bearing.

Mounting

Skill and cleanliness are essential when mounting bearings, to make sure that they perform satisfactorily and attain their full potential. Above all, the correct method of mounting should be chosen and suitable tools used. This is particularly important, where sealed SKF spherical roller bearings are concerned, since misalignments of the inner ring relative to the outer ring in excess of $0,5^\circ$ may damage the seals. For optimum results in mounting and dismounting bearings, SKF offers a full range of tools and equipment. Please refer to the "Related SKF products" section on **page 58**.

Bearings with cylindrical bore

When mounting bearings with cylindrical bore, the ring with the tighter fit is normally mounted first.

The force required to mount a bearing increases according to the bearing size. Therefore, it is not always possible to press large bearings onto a cylindrical shaft or into a housing in the cold state. In this case, either the inner ring or the housing should be expanded by heating before mounting.

To mount with an interference fit on a shaft the bearing should be heated to some 80 to 90 °C (180 to 200 °F) above the temperature of the shaft. Please remember that sealed bearings should never be heated to more than 110 °C (230 °F).

The use of an SKF induction heater has been found very advantageous (→ **fig 2**). It heats the bearing rapidly, and a built-in thermostat prevents bearing damage caused by overheating. Non-metallic components such as seals remain cold, as does the heater itself.

Mounting bearings by cooling the shaft or the bearing is not recommended, as the very low temperatures required inevitably cause condensation, thus creating a risk of corrosion.

Correct storage of bearings



Fig 1

SKF induction heater



Fig 2

Bearings with tapered bore

Bearings with tapered bore are always mounted with an interference on the shaft. They can be mounted on adapter or withdrawal sleeves or directly on to tapered journals.

When dimensioning a tapered journal, the distance between the centre of the bearing in its final mounted position and a reference face on the shaft should be used as a basis (→ fig 3). When the dimension B_a has been established, the dimensioning of the journal should be continued as described in SKF catalogue 4003 “Large bearings”.

Spherical roller bearings up to 200 mm bore diameter may be driven up on to a tapered journal or a withdrawal sleeve using a shaft nut and on to an adapter sleeve using the sleeve nut and a spanner (→ fig 4).

The application of the high drive-up forces required by larger bearings can be facilitated using the oil injection method (→ fig 5). This necessitates the provision of oil supply ducts in the journals and oil distribution grooves in the seating. Further reduction of the mounting effort can be achieved by using the oil injection method in combination with an SKF hydraulic nut.

For bearings which are to be hot mounted, the final axial position on the seating has to be predetermined by means of, for instance, a tailor-made spacer ring (→ fig 6). When cold, the bearing will obtain its correct interference fit.

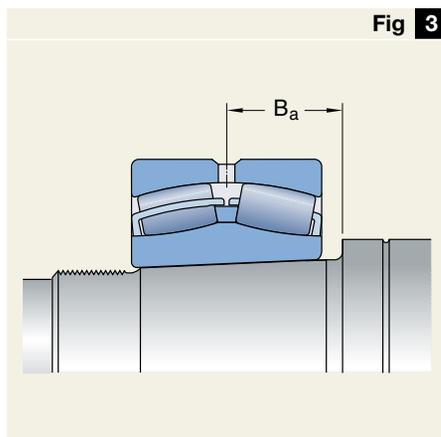

Dimensioning of tapered journals

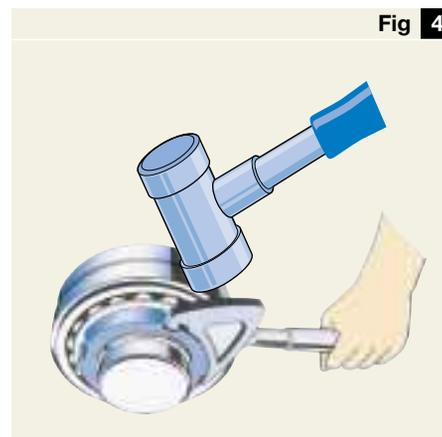

Drive-up of medium size bearing

Drive-up of large size bearing

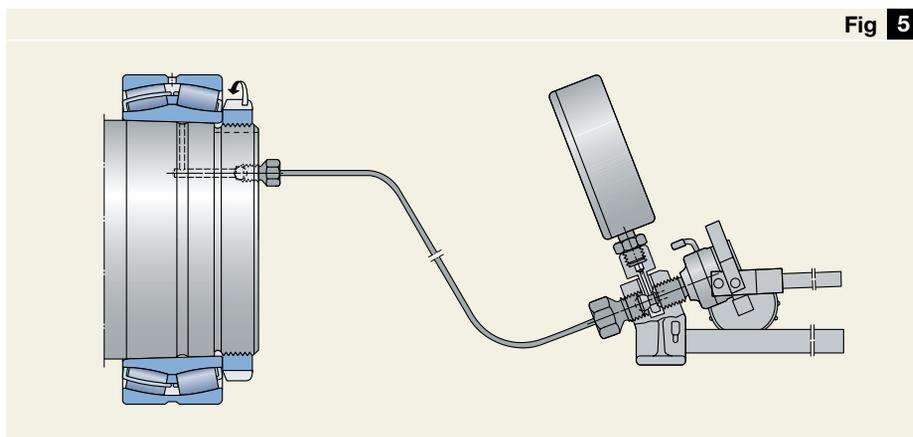

Tailor-made spacer ring used to position the bearing axially

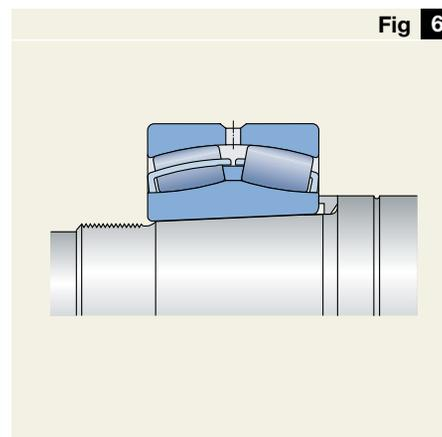

The reduction in radial internal clearance of open bearings or the axial displacement of the inner ring on its tapered seating is used as a measure of the degree of interference (→ fig 7).

To effectively mount sealed bearings with a tapered bore, it is only possible to use the drive-up distance as a measure, and the “SKF drive-up method” is recommended. It allows the starting position of the bearing to be easily and accurately determined by applying a well-defined oil pressure in the hydraulic nut. The correct fit is then achieved by controlling the axial drive-up from this position.

The SKF drive-up method incorporates the use of a new type of hydraulic nut fitted with a dial indicator to control the drive-up and a specially calibrated pressure gauge, mounted on the selected pump (→ fig 8).

Fig 7

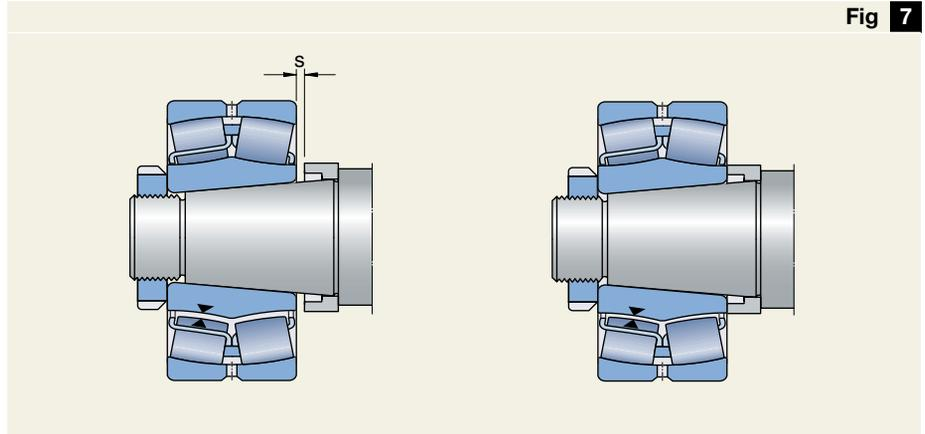

Desired interference obtained by measuring clearance reduction or axial drive-up

Mounting a bearing using the SKF drive-up method

Dismounting a bearing from a cylindrical seat using the oil injection method

Fig 8

Fig 9

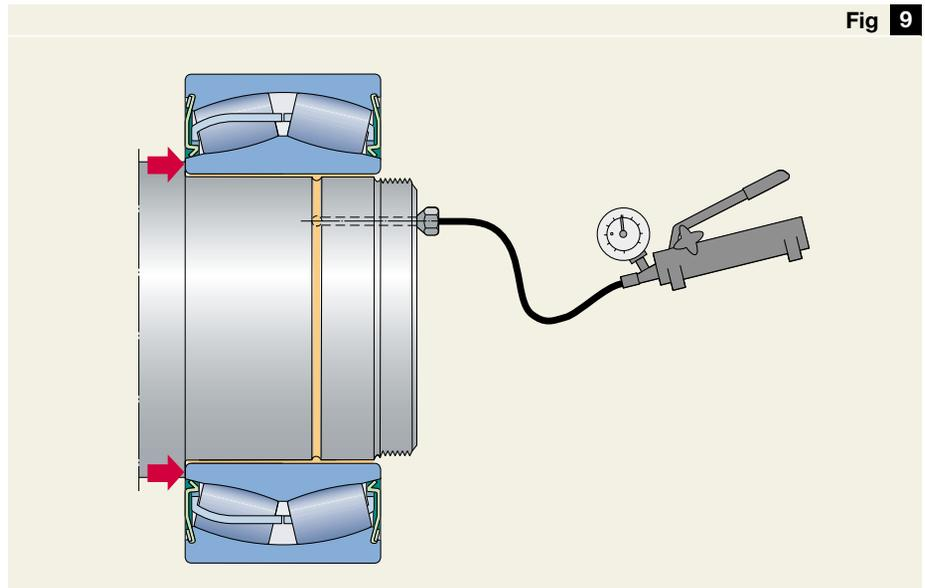
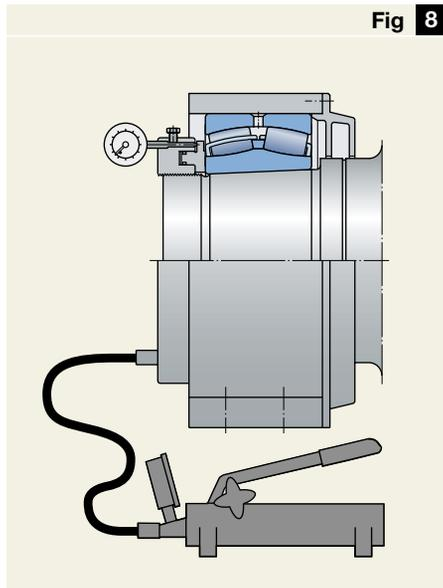

Dismounting

The force required to remove a bearing is generally greater than the mounting force, particularly if, after a long period of service, fretting corrosion is present. If bearings or other associated components are to be re-used after inspection, they must be dismantled as carefully as they were mounted, and the dismantling force should never be applied through the rolling elements.

Bearings with cylindrical bore

Small bearings can generally be removed using a mechanical puller. These withdrawal tools should grip over the rings from the inside or outside and contact the side faces.

Dismounting larger bearings with bore diameters of 80 mm and above with an interference fit on the shaft is considerably eased, if the SKF oil injection method is used (→ fig 9).

Bearings with tapered bore

To remove spherical roller bearings from tapered journals, the oil injection method is recommended (→ fig 10). The film of pressurised oil separates the two mating surfaces and makes the bearing slide off easily.

Bearings mounted on adapter or withdrawal sleeves are most easily

Safety note

To avoid damage or accidents when dismantling bearings from tapered seatings using the oil injection method, always make sure that the bearing is blocked at the shaft end, e.g. by a lock nut, to prevent it from falling off.

removed using a hydraulic nut (→ fig 11). By using sleeves with oil ducts and oil distribution grooves, the oil injection method easily facilitates the removal of large bearings (→ fig 12).

See also SKF publication 4100 “SKF Bearing Maintenance Handbook”.

Fig 10

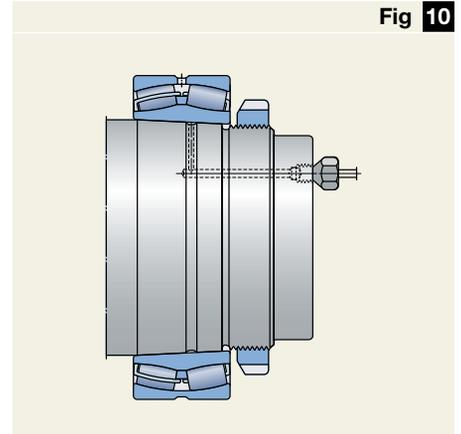

Dismounting a bearing from a tapered journal using the SKF oil injection method

Dismounting bearings on adapter and withdrawal sleeves with hydraulic nuts

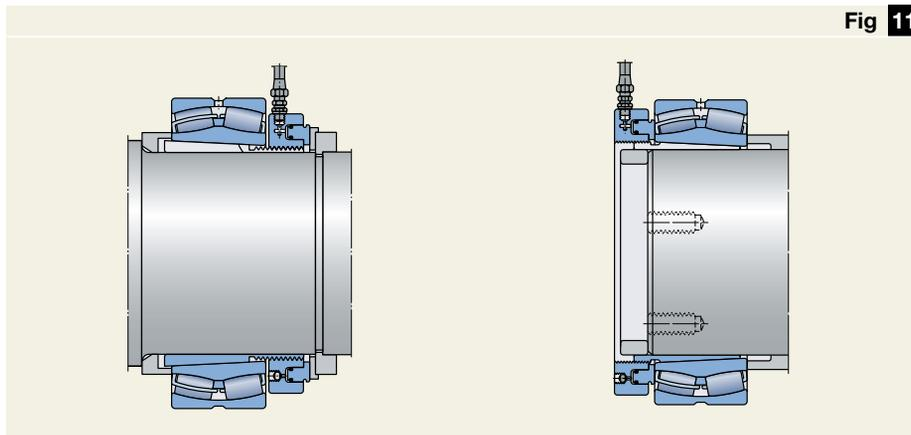

Fig 11

Dismounting a large size bearing on withdrawal sleeve with oil ducts and grooves

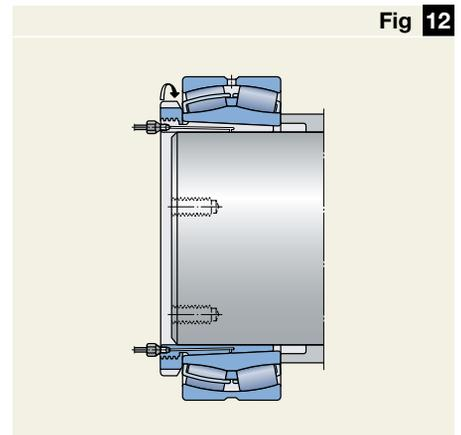

Fig 12

Lubrication and maintenance

Oil lubrication

For oil lubrication of spherical roller bearings, oil bath and circulating oil lubrication are the two main options.

Oil bath

This is the most simple method of oil lubrication (→ fig 1). The oil, which is picked up by the rotating components of the bearing, is distributed within the bearing and then flows back to the oil bath.

The oil level should be such that it almost reaches the centre of the lowest roller when the bearing is stationary. The speed ratings for oil lubrication given in the product tables apply to this method of lubrication. Even under optimum operating conditions, the oil must be changed at least once a year.

Circulating oil

In the circulating system, the oil can be continuously filtered and/or cooled (→ fig 2). This significantly increases the service life of the oil, helping to avoid frequent oil changes.

The circulation can be produced by a pump. Adequately dimensioned ducts must allow the oil to leave the arrangement after passing through the bearing.

An intermediate form of oil lubrication is one where the oil is splashed up from the oil bath by other components, e.g. gears in a gearbox.

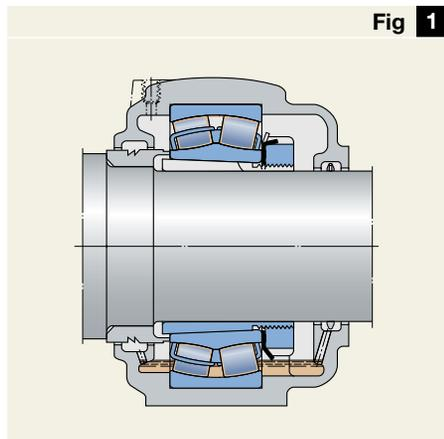

Spherical roller bearing application lubricated by oil bath

Spherical roller bearing application lubricated by circulating oil

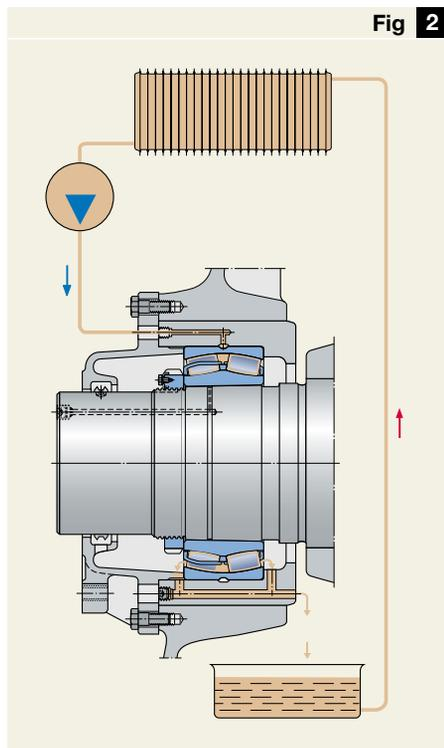

Grease lubrication

Today's modern greases allow an increasing number of maintenance-free bearing applications which are lubricated for life. Here, the selection of sealed SKF spherical roller bearings is the optimum choice, both technically and economically. These bearings are filled with the SKF lithium base grease LGEP 2 before leaving the factory (→ Table 1) and are ready to mount and operate.

In cases where the operating conditions are so harsh that very frequent relubrication is needed or where sealed SKF spherical roller bearings are not available, SKF offers a full range of greases and tools to enable proper lubrication of the bearing (→ section "Lubricants and lubrication equipment" on page 60).

Relubrication

It is only possible to determine the time at which relubrication is required based on statistics. The definition used by SKF for the recommendations regarding relubrication intervals relates to a time at which 99 % of the bearings are still reliably lubricated, i.e. they correspond to an L_1 grease life which is the relubrication interval t_r . The L_{10} grease life is approximately twice the L_1 life.

If the L_{10} grease life corresponds to, or exceeds, the L_{10} life of the bearing, the bearing may be considered as being lubricated for life, and relubrication will not be required.

The following recommendations are based on the results of long-term tests in various applications. They do not apply where water and/or particulate contaminants can penetrate the bearing arrangement. In such cases it is advisable to replenish or renew the grease fill in the arrangement more frequently to remove moisture or other contaminants.

Relubrication intervals

Under normal conditions the relubrication interval t_r can be determined from **Diagram 1** based on

- the rotational speed n and
- the bearing bore diameter d .

The diagram is valid for bearings, which are lubricated with a quality lithium base grease, on horizontal shafts in stationary machines where loads are normal and the operating temperature does not exceed the “reference temperature” for the grease; this is usually 70 °C (158 °F).

Lubricating greases age with time and this process is accelerated at elevated temperatures. Therefore, the relubrication interval obtained from the diagram should be halved for every 15 °C (27 °F) above the reference temperature. At temperatures below 70 °C (158 °F), the relubrication interval may be extended.

Where bearings having bore diameters larger than some 300 mm are concerned, the high specific loads mean that adequate lubricant supply to the rolling contacts can only be secured if relubrication is more frequent than suggested by the diagram. For this reason the relevant curves are shown as dashed lines. In such cases continuous relubrication is recommended.

Diagram 1

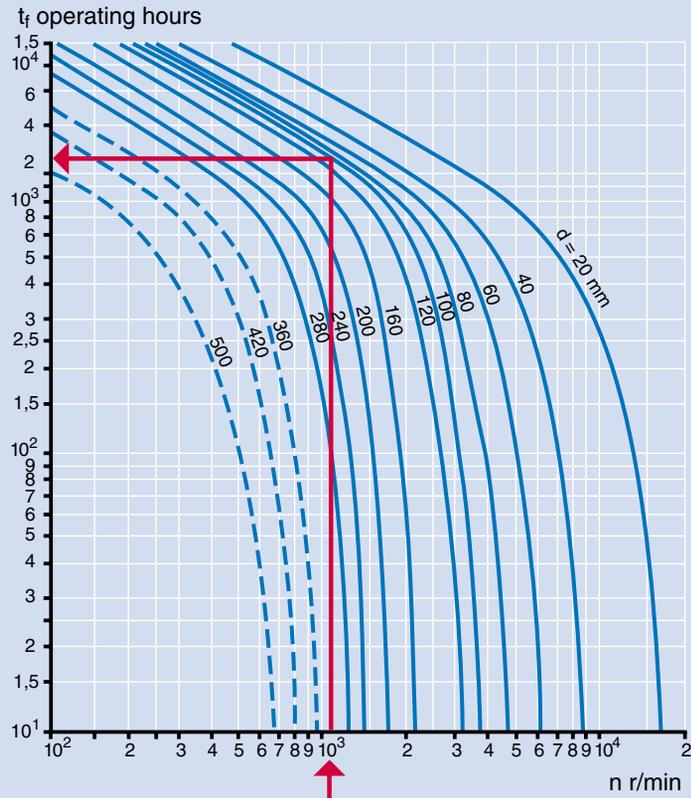

Example

A spherical roller bearing with a bore diameter (d) of 100 mm rotates at 1 000 r/min. The operating temperature varies between 60 and 70 °C (140 to 158 °F). What is the correct relubrication interval? Follow the line from 10^3 on the speed (x) axis to the intersection of the curve for $d = 100$ mm. Then follow a line from this intersection horizontally across to the value of t_r which is approximately 2 000. The relubrication interval is therefore 2 000 operating hours.

Relubrication intervals for grease lubricated spherical roller bearings

Technical data for SKF grease LGEP 2

Table 1

Property	SKF grease LGEP 2
Consistency (NLGI Scale)	2
Soap base	lithium
Colour	light brown
Base oil	mineral
Operating temperature range, °C (°F)	-20 to +110 (-4 to +230)
Reference temperature, °C (°F)	60 (140)
Dropping point to ISO 2176, °C (°F)	min. 180 (356)
Kinematic viscosity of base oil at 40 °C, mm ² /s	200
at 100 °C, mm ² /s	16

See also “SKF Interactive Engineering Catalogue” or SKF “General Catalogue”.

Grease quantity for periodic relubrication

If the relubrication interval is less than 6 months, it is recommended to replenish the grease fill in the bearing arrangement at intervals corresponding to $0,5 t_f$. The complete grease fill should be replaced after three replenishments.

Suitable quantities to be added for open bearings can be obtained from

$$G_p = 0,005 D B$$

and for sealed bearings from

$$G_p = 0,0015 D B$$

where

G_p = grease quantity to be added when replenishing, g

D = bearing outside diameter, mm

B = total bearing width, mm

The bearing must rotate during relubrication to achieve proper distribution of the grease.

Grease quantity for continuous relubrication

The grease quantity to be continuously supplied can be obtained from

$$G_k = (0,3 \dots 0,5) D B \times 10^{-4}$$

where

G_k = grease quantity to be continuously supplied, g/h

D = bearing outside diameter, mm

B = total bearing width, mm

Continuous relubrication can be efficiently achieved using the SKF SYSTEM 24 lubricator.

Relubrication of sealed SKF spherical roller bearings

The sealed spherical roller bearings shown in the product tables (page 54 onwards) have an annular groove and three lubrication holes as standard. To prevent moisture from penetrating and to retain the grease in the bearing a polymer band in the groove covers the lubrication holes (→ fig 3).

If it is anticipated that bearing relubrication will be necessary during operation, the band should be removed before the bearing is mounted. When relubricating, grease should be slowly pressed into the bearing as it rotates until fresh grease emerges from the sealing lips. Excess pressure should be avoided to prevent seal damage.

A polymer band in the annular groove covers the lubrication holes in the outer ring of sealed bearings

Retaining rings hold the seals in the outer ring

Fig 3

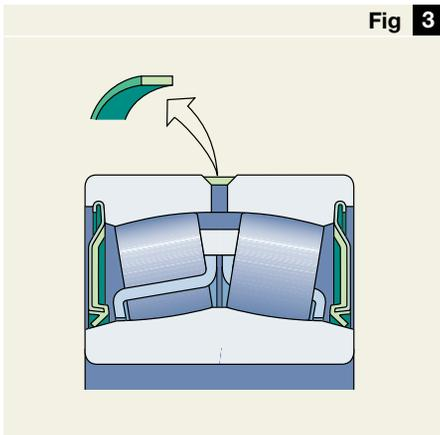
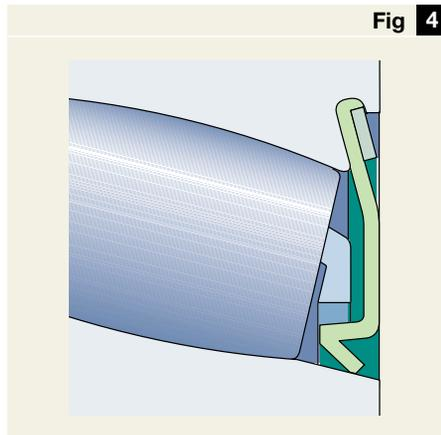

Fig 4



Maintenance

The seals of SKF spherical roller bearings with a bore diameter of 110 mm and above are secured by retaining rings inserted in the outer ring (→ **fig 4**). The seals can be removed from the bearing so that the bearing can be inspected, washed and regreased, after which the seals can be reinserted and secured. To avoid damage to the seals, this work has to be done with care, using suitable, well rounded tools with no sharp edges.

1. Remove the retaining ring by inserting a tool under the recessed end of the retaining ring (→ **fig 5**) and pushing it out of the groove.
2. Remove the second retaining ring as above.
3. Swivel out the inner ring, so that the seals are pushed out by the rollers.
4. The bearing, seals and retaining rings can now be washed
5. Inspect the parts for further usability.
6. Regrease the bearing with inner ring swivelled out.
7. Align the bearing and put it on a clean surface for remounting the seals.
8. Insert the seal as far as possible into its groove in the outer ring. Hold down the already inserted part of the seal with one hand, and press in the remainder, stepwise with the thumb of the other hand (→ **fig 6**).

9. Mount the retaining ring by inserting the rectangular end first. Holding this part down, press in the remainder stepwise with a tool, until the whole retaining ring properly contacts the seal as shown in **fig 4**.
10. Mount the second seal according to steps 7 to 9.
11. If the bearing is not immediately re-used, preserve the bearing surfaces with oil and make sure that the bearing is well packed.

Removing a retaining ring



Inserting the seal in the outer ring



Bearing data – general

Designs

Depending on the size and the series, SKF spherical roller bearings incorporate one of the internal designs shown below. Common features of all designs include symmetrical rollers and a floating guide ring between the roller rows. The arrangement of the guide ring as well as the cage execution are different for the various designs.

E design
d ≤ 65 mm

Guide ring centred on the inner ring, two window-type steel cages.

E design
d > 65 mm

Guide ring centred on the cages, two window-type steel cages.

C, CC, EC and ECC designs

Guide ring centred on the inner ring, two window-type steel cages.

CA, CAC, CAF, ECA and ECAF designs

Guide ring centred on the inner ring, retaining flanges on the inner ring, one-piece machined cage of brass or steel (suffix F).

CAFA and CAMA designs

Guide ring centred on the inner ring, retaining flanges on the inner ring, one-piece machined cage of steel (CAFA) or brass (CAMA).

Explorer

The designations of Explorer bearings are printed in blue in the product tables.

Cylindrical or tapered bore

SKF spherical roller bearings are available with cylindrical bore and tapered bore. The tapered bore of bearings of series 240, 241, 248 and 249 has a taper of 1:30, whereas the bore of the other bearing series have a taper of 1:12.

Annular groove and lubrication holes

Efficient lubrication of the SKF spherical roller bearings is facilitated by either

- three lubrication holes and an annular groove (E design or suffix W33) or
- three lubrication holes without annular groove (suffix W20).

Dimensions

The boundary dimensions of SKF spherical roller bearings with and without seals are in accordance with ISO 15:1998, except for the width of the

sealed bearings of series BS2-22.

These are basically series 222 E or 222 CC bearings, but are slightly wider to integrate the seals.

Tolerances

SKF spherical roller bearings with cylindrical and tapered bore are produced as standard with normal tolerances corresponding to ISO 492:1994.

Running accuracy

In high-speed bearing arrangements the demands on running accuracy are often higher than usual. For such bearing arrangements, the C08 execution is recommended which has running accuracy to ISO tolerance class 5 specifications. The values for the running accuracy are in accordance with ISO 492:1994. Check availability of the C08 specification bearing before ordering.

Internal clearance

SKF spherical roller bearings are manufactured as standard with Normal radial internal clearance. Nearly all the bearings are also available with a larger C3 internal clearance and some can be supplied with a even larger C4 clearance. Some sizes can be delivered with C2 internal clearance which is smaller than Normal. Check the availability of bearings with radial

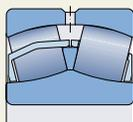

E design
d ≤ 65 mm

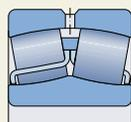

E design
d > 65 mm



C, CC, EC and
ECC designs

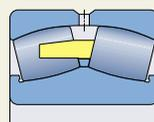

CA, CAC, CAF, ECA
and ECAF designs

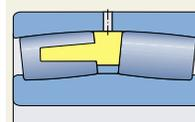

CAFA and
CAMA designs



W20



W33

internal clearances other than Normal before ordering. The various radial internal clearances are in accordance with ISO 5753:1991 and shown in **Tables 1** and **2**. They are valid for zero measuring load and before mounting.

Table 1

Bore diameter d		Radial internal clearance C2				C3		C4		C5	
over	incl.	min	max	Normal		min	max	min	max	min	max
mm		µm									
18	24	10	20	20	35	35	45	45	60	60	75
24	30	15	25	25	40	40	55	55	75	75	95
30	40	15	30	30	45	45	60	60	80	80	100
40	50	20	35	35	55	55	75	75	100	100	125
50	65	20	40	40	65	65	90	90	120	120	150
65	80	30	50	50	80	80	110	110	145	145	185
80	100	35	60	60	100	100	135	135	180	180	225
100	120	40	75	75	120	120	160	160	210	210	260
120	140	50	95	95	145	145	190	190	240	240	300
140	160	60	110	110	170	170	220	220	280	280	350
160	180	65	120	120	180	180	240	240	310	310	390
180	200	70	130	130	200	200	260	260	340	340	430
200	225	80	140	140	220	220	290	290	380	380	470
225	250	90	150	150	240	240	320	320	420	420	520
250	280	100	170	170	260	260	350	350	460	460	570
280	315	110	190	190	280	280	370	370	500	500	630
315	355	120	200	200	310	310	410	410	550	550	690
355	400	130	220	220	340	340	450	450	600	600	750
400	450	140	240	240	370	370	500	500	660	660	820
450	500	140	260	260	410	410	550	550	720	720	900
500	560	150	280	280	440	440	600	600	780	780	1 000
560	630	170	310	310	480	480	650	650	850	850	1 100
630	710	190	350	350	530	530	700	700	920	920	1 190
710	800	210	390	390	580	580	770	770	1 010	1 010	1 300
800	900	230	430	430	650	650	860	860	1 120	1 120	1 440
900	1 000	260	480	480	710	710	930	930	1 220	1 220	1 570
1 000	1 120	290	530	530	780	780	1 020	1 020	1 330	1 330	1 720
1 120	1 250	320	580	580	860	860	1 120	1 120	1 460	1 460	1 870
1 250	1 400	350	640	640	950	950	1 240	1 240	1 620	1 620	2 060
1 400	1 600	400	720	720	1 060	1 060	1 380	1 380	1 800	1 800	2 300
1 600	1 800	450	810	810	1 180	1 180	1 550	1 550	2 000	2 000	2 550

Radial internal clearance of spherical roller bearings with cylindrical bore

Table 2

Bore diameter d		Radial internal clearance C2				C3		C4		C5	
over	incl.	min	max	Normal		min	max	min	max	min	max
mm		µm									
24	30	20	30	30	40	40	55	55	75	–	–
30	40	25	35	35	50	50	65	65	85	85	105
40	50	30	45	45	60	60	80	80	100	100	130
50	65	40	55	55	75	75	95	95	120	120	160
65	80	50	70	70	95	95	120	120	150	150	200
80	100	55	80	80	110	110	140	140	180	180	230
100	120	65	100	100	135	135	170	170	220	220	280
120	140	80	120	120	160	160	200	200	260	260	330
140	160	90	130	130	180	180	230	230	300	300	380
160	180	100	140	140	200	200	260	260	340	340	430
180	200	110	160	160	220	220	290	290	370	370	470
200	225	120	180	180	250	250	320	320	410	410	520
225	250	140	200	200	270	270	350	350	450	450	570
250	280	150	220	220	300	300	390	390	490	490	620
280	315	170	240	240	330	330	430	430	540	540	680
315	355	190	270	270	360	360	470	470	590	590	740
355	400	210	300	300	400	400	520	520	650	650	820
400	450	230	330	330	440	440	570	570	720	720	910
450	500	260	370	370	490	490	630	630	790	790	1 000
500	560	290	410	410	540	540	680	680	870	870	1 100
560	630	320	460	460	600	600	760	760	980	980	1 230
630	710	350	510	510	670	670	850	850	1 090	1 090	1 360
710	800	390	570	570	750	750	960	960	1 220	1 220	1 500
800	900	440	640	640	840	840	1 070	1 070	1 370	1 370	1 690
900	1 000	490	710	710	930	930	1 190	1 190	1 520	1 520	1 860
1 000	1 120	530	770	770	1 030	1 030	1 300	1 300	1 670	1 670	2 050
1 120	1 250	570	830	830	1 120	1 120	1 420	1 420	1 830	1 830	2 250
1 250	1 400	620	910	910	1 230	1 230	1 560	1 560	2 000	2 000	2 450
1 400	1 600	680	1 000	1 000	1 350	1 350	1 720	1 720	2 200	2 200	2 700
1 600	1 800	750	1 110	1 110	1 500	1 500	1 920	1 920	2 400	2 400	2 950

Radial internal clearance of spherical roller bearings with tapered bore

Misalignment

Spherical roller bearings can accommodate misalignment between the outer and inner rings without affecting the bearing. The guideline values of permissible misalignment given in **Table 3** refer to open bearings and are valid for normal loads ($C/P > 10$) and operating conditions, and when the inner ring rotates under constant misalignment.

Whether the stated values of misalignment between the outer ring and inner ring can be fully exploited or not depends on the design of the bearing arrangement, the type of seals used etc.

Under the same conditions, sealed SKF spherical roller bearings can accommodate angular misalignments of the shaft with respect to the housing of up to approximately 0,5°.

Influence of operating temperature on the bearing materials

SKF spherical roller bearings rings and rollers are special heat treated so that they can be used at temperatures up to +200 °C (390 °F) for up to 2 500 hours or for brief periods at even higher temperatures without any inadmissible dimensional changes occurring. If provision is made to accommodate slight changes of fits and clearance, even higher temperatures or longer periods can be accommodated.

Sealed SKF spherical roller bearings should not be used at operating temperatures above +110 °C (230 °F) as this would be detrimental to the seals and grease.

Axial load carrying capacity

Because of their special internal design, SKF spherical roller bearings not only have lower friction than other spherical roller bearings, they are also able to accommodate appreciably heavier axial loads. However, if $F_a/F_r > e$ (→ **product tables**), a more frequent relubrication than usual is recommended.

Speed ratings

Due to the friction generated by contact seals, the speed ratings for sealed bearings for normal temperatures are approximately 40 % of those for the corresponding open bearings.

Table **3**

Bearing series	Permissible angular misalignment
–	degrees
213	1
222	1,5
223	2
230	1,5
231	1,5
232	2,5
238	1
239	1,5
240	2
241	2,5
248	1,5
249	1,5

Guideline values for permissible angular misalignment

Supplementary designations

The designation suffixes used to identify certain features of SKF spherical roller bearings are explained below. The suffixes used to identify bearing (and cage) design, e.g. CC or E, are not included here as they are explained under "Designs".

C2	Radial internal clearance smaller than Normal
C3	Radial internal clearance greater than Normal
C4	Radial internal clearance greater than C3
C08	Increased running accuracy to ISO tolerance class 5
C083	C08 + C3
C084	C08 + C4
2CS	Sheet steel reinforced rubbing seals of nitrile rubber (NBR) at both sides of bearing. Grease fill 25 to 35 % with SKF grease LGEP 2. Annular groove and three lubrication holes in outer ring.
2CSW	2CS + W
2CS2	Sheet steel reinforced rubbing seals of fluoro rubber (FPM) at both sides of bearing. Grease fill 70 to 100 % with a polyurea high temperature grease. Annular groove and three lubrication holes in the outer ring.
2CS2W	2CS2 + W
2CS5	Sheet steel reinforced rubbing seals of hydrogenated nitrile rubber (HNBR) at both sides of bearing. Grease fill 70 to 100 % with a polyurea high temperature grease. Annular groove and three lubrication holes in the outer ring.
2CS5W	2CS5 + W

HA3	Case hardened inner ring
K	Tapered bore, taper 1:12
K30	Tapered bore, taper 1:30
VA405	Bearing for vibrating applications
VA406	Bearing for vibrating applications with PTFE-coated bore
VE552(E)	Outer ring with three equally spaced threaded holes in one side face to take hoisting tackle; the E indicates that appropriate eye bolts are supplied with the bearings
VE553(E)	Outer ring with three equally spaced threaded holes in both side faces to take hoisting tackle; the E indicates that appropriate eye bolts are supplied with the bearings
VG186	Hardened cages
VQ424	Running accuracy better than C08
VT143	Grease fill 25 to 35 % with SKF grease LGEP 2
W	No relubrication facility in outer ring
W20	Three lubrication holes in outer ring
W26	Six lubrication holes in inner ring
W33	Annular groove and three lubrication holes in outer ring
W77	Plugged W33 lubrication holes
W509	W26 + W33
235220	Case hardened inner ring with helical groove in bore

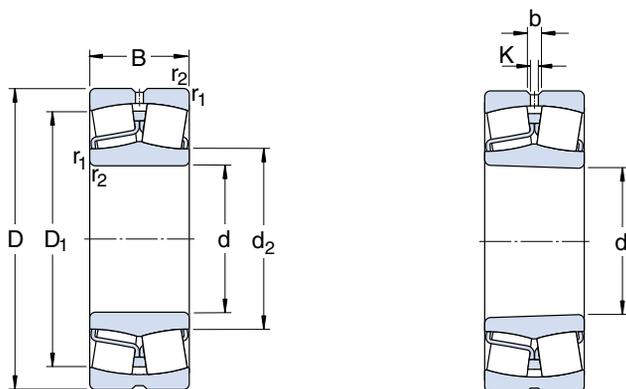

Principal dimensions			Basic load ratings		Fatigue load limit P _u	Speed ratings		Mass	Designations	
d	D	B	dynamic C	static C ₀		Lubrication grease	oil		Bearings with cylindrical bore	tapered bore
mm			kN		kN	r/min		kg	–	
20	52	18	49	44	4,75	8 500	11 000	0,28	22205/20 E	–
25	52	18	49	44	4,75	8 500	11 000	0,19	22205 E	22205 EK
	62	17	41,4	41,5	4,55	6 700	8 500	0,28	21305 CC	–
30	62	20	56	52	5,5	7 500	9 500	0,30	22206 CC/W33	22206 CCK/W33
	72	19	55,2	61	6,8	6 000	7 500	0,41	21306 CC	–
35	72	23	76,5	73,5	8	6 300	8 000	0,46	22207 CC/W33	22207 CCK/W33
	80	21	65,6	72	8,15	5 300	6 700	0,55	21307 CC	–
40	80	23	96,5	90	9,8	6 000	7 500	0,53	22208 E	22208 EK
	90	23	82,8	98	11	4 500	5 600	0,76	21308 CC	21308 CCK
	90	33	150	140	15	4 500	5 600	1,05	22308 E	22308 EK
45	85	23	90	88	9,5	5 300	6 700	0,60	22209 CC/W33	22209 CCK/W33
	100	25	125	127	13,7	4 500	5 600	0,99	21309 E	21309 EK
	100	36	183	183	19,6	3 800	4 800	1,40	22309 E	22309 EK
50	90	23	96,5	100	11	5 000	6 300	0,65	22210 CC/W33	22210 CCK/W33
	110	27	156	166	18,6	4 000	5 000	1,35	21310 E	21310 EK
	110	40	220	224	24	3 400	4 300	1,90	22310 E	22310 EK
55	100	25	125	127	13,7	4 500	5 600	0,84	22211 E	22211 EK
	120	29	156	166	18,6	4 000	5 000	1,70	21311 E	21311 EK
	120	43	270	280	30	3 200	4 000	2,45	22311 E	22311 EK
60	110	28	156	166	18,6	4 000	5 000	1,15	22212 E	22212 EK
	130	31	212	240	26,5	3 400	4 300	2,10	21312 E	21312 EK
	130	46	310	335	36,5	2 800	3 600	3,10	22312 E	22312 EK
65	120	31	193	216	24	3 800	4 800	1,55	22213 E	22213 EK
	140	33	236	270	29	3 200	4 000	2,55	21313 E	21313 EK
	140	48	340	360	38	2 600	3 400	3,75	22313 E	22313 EK
70	125	31	208	228	25,5	3 600	4 500	1,55	22214 E	22214 EK
	150	35	285	325	34,5	2 800	3 600	3,10	21314 E	21314 EK
	150	51	400	430	45	2 200	3 000	4,55	22314 E	22314 EK
75	115	40	152	232	28,5	2 600	3 400	1,55	24015 CC/W33	–
	130	31	212	240	26,5	3 400	4 300	1,70	22215 E	22215 EK
	160	37	285	325	34,5	2 800	3 600	3,75	21315 E	21315 EK
	160	55	440	475	48	2 200	3 000	5,55	22315 E	22315 EK
80	140	33	236	270	29	3 200	4 000	2,10	22216 E	22216 EK
	170	39	325	375	39	2 600	3 400	4,45	21316 E	21316 EK
	170	58	490	540	54	2 000	2 800	6,60	22316 E	22316 EK

The designations of Explorer bearings are printed in blue

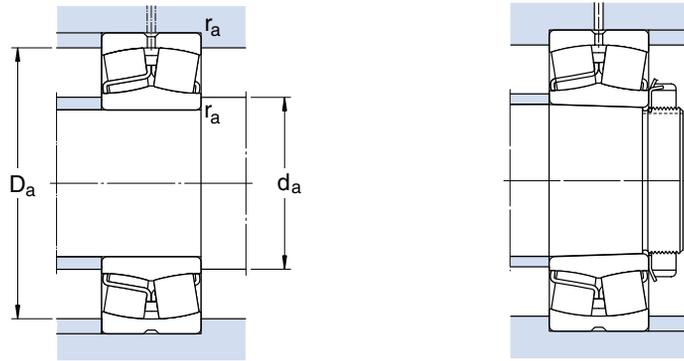

Dimensions

Abutment and fillet dimensions

Calculation factors

d	d ₂	D ₁	b	K	r _{1,2} min	d _a min	D _a max	r _a max	e	Y ₁	Y ₂	Y ₀
mm						mm			-			
20	31,2	44,2	3,7	2	1	26	46	1	0,35	1,9	2,9	1,8
	35,7	50,7	-	-	1,1	32	55	1	0,30	2,3	3,4	2,2
30	37,7	52,4	3,7	2	1	36	56	1	0,33	2	3	2
	43,3	58,82	-	-	1,1	37	65	1	0,27	2,5	3,7	2,5
35	44,5	60,9	3,7	2	1,1	42	65	1	0,31	2,2	3,3	2,2
	47,2	65,6	-	-	1,5	44	71	1,5	0,28	2,4	3,6	2,5
40	49,6	69,4	5,5	3	1,1	47	73	1	0,28	2,4	3,6	2,5
	55,6	74,3	-	-	1,5	49	81	1,5	0,26	2,6	3,9	2,5
	49,9	74,3	5,5	3	1,5	49	81	1,5	0,37	1,8	2,7	1,8
45	54,9	73,6	5,5	3	1,1	52	78	1	0,26	2,6	3,9	2,5
	65,3	87,9	5,5	3	1,5	54	91	1,5	0,24	2,8	4,2	2,8
	57,6	83,1	5,5	3	1,5	54	91	1,5	0,37	1,8	2,7	1,8
50	60,1	78,8	5,5	3	1,1	57	83	1	0,24	2,8	4,2	2,8
	72,6	96,5	5,5	3	2	60	100	2	0,24	2,8	4,2	2,8
	63,9	91,9	5,5	3	2	60	100	2	0,37	1,8	2,7	1,8
55	65,3	87,9	5,5	3	1,5	64	91	1,5	0,24	2,8	4,2	2,8
	72,6	96	5,5	3	2	65	110	2	0,24	2,8	4,2	2,8
	70,1	102	5,5	3	2	66	109	2	0,35	1,9	2,9	1,8
60	72,6	96,3	5,5	3	1,5	69	101	1,5	0,24	2,8	4,2	2,8
	87,8	115	5,5	3	2,1	72	118	2	0,22	3	4,6	2,8
	77,9	110	5,5	3	2,1	72	118	2	0,35	1,9	2,9	1,8
65	80	106	5,5	3	1,5	74	111	1,5	0,24	2,8	4,2	2,8
	94,7	124	5,5	3	2,1	77	128	2	0,22	3	4,6	2,8
	81,6	118	8,3	4,5	2,1	77	128	2	0,35	1,9	2,9	1,8
70	83	111	5,5	3	1,5	79	116	1,5	0,22	3	4,6	2,8
	101	133	5,5	3	2,1	82	138	2	0,22	3	4,6	2,8
	90,3	128	8,3	4,5	2,1	82	138	2	0,33	2	3	2
75	84,1	100	5,5	3	1,1	81	109	1	0,28	2,4	3,6	2,5
	87,8	115	5,5	3	1,5	84	121	1,5	0,22	3	4,6	2,8
	101	133	5,5	3	2,1	87	148	2	0,22	3	4,6	2,8
	92,8	135	8,3	4,5	2,1	87	148	2	0,35	1,9	2,9	1,8
80	94,7	127	5,5	3	2	91	129	2	0,22	3	4,6	2,8
	106	141	5,5	3	2,1	92	158	2	0,24	2,8	4,2	2,8
	98,3	143	8,3	4,5	2,1	92	158	2	0,35	1,9	2,9	1,8

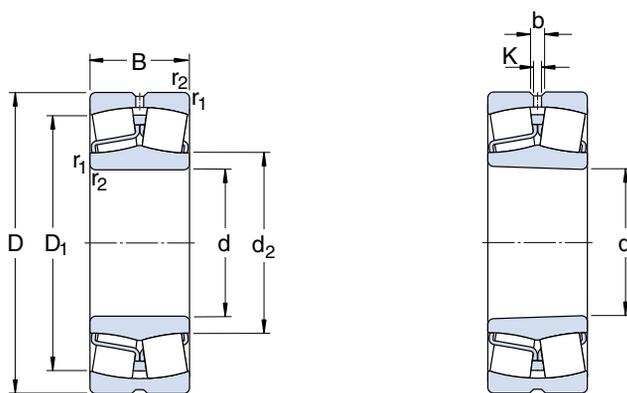

Principal dimensions			Basic load ratings		Fatigue load limit P_u	Speed ratings		Mass	Designations	
d	D	B	dynamic C	static C_0		Lubrication grease	oil		Bearings with cylindrical bore	tapered bore
mm			kN		kN	r/min		kg	–	
85	150	36	285	325	34,5	2 800	3 600	2,65	22217 E	22217 EK
	180	41	325	375	39	2 600	3 400	5,20	21317 E	21317 EK
	180	60	550	620	61	1 900	2 600	7,65	22317 E	22317 EK
90	160	40	325	375	39	2 600	3 400	3,40	22218 E	22218 EK
	160	52,4	311	440	48	1 900	2 600	4,65	23218 CC/W33	23218 CCK/W33
	190	43	380	450	46,5	2 400	3 200	6,10	21318 E	21318 EK
	190	64	610	695	67	1 800	2 400	9,05	22318 E	22318 EK
95	170	43	380	450	46,5	2 400	3 200	4,15	22219 E	22219 EK
	200	45	425	490	49	2 200	3 000	7,05	21319 E	21319 EK
	200	67	670	765	73,5	1 800	2 400	10,5	22319 E	22319 EK
100	150	50	248	415	45,5	1 900	2 600	3,15	24020 CDC/W33	–
	165	52	322	490	53	2 000	2 800	4,55	23120 CC/W33	23120 CCK/W33
	165	65	455	640	68	1 700	2 200	5,65	24120 CC/W33	–
	180	46	425	490	49	2 200	3 000	4,90	22220 E	22220 EK
	180	60,3	414	600	63	1 700	2 200	6,85	23220 CC/W33	23220 CCK/W33
	215	47	425	490	49	2 200	3 000	8,60	21320 E	21320 EK
	215	73	815	950	88	1 700	2 200	13,5	22320 E	22320 EK
110	170	45	267	440	46,5	2 200	3 000	3,80	23022 CC/W33	23022 CCK/W33
	180	56	430	585	61	1 900	2 600	5,75	23122 CC/W33	23122 CCK/W33
	180	69	460	750	78	1 600	2 000	7,10	24122 CC/W33	24122 CCK30/W33
	200	53	560	640	63	2 000	2 800	7,00	22222 E	22222 EK
	200	69,8	518	765	76,5	1 600	2 000	9,85	23222 CC/W33	23222 CCK/W33
	240	80	950	1 120	100	1 500	1 900	18,4	22322 E	22322 EK
120	180	46	355	500	52	2 000	2 800	4,20	23024 CC/W33	23024 CCK/W33
	180	60	430	670	68	1 600	2 000	5,45	24024 CC/W33	24024 CCK30/W33
	200	62	510	695	71	1 800	2 400	8,00	23124 CC/W33	23124 CCK/W33
	200	80	575	950	95	1 400	1 800	10,3	24124 CC/W33	24124 CCK30/W33
	215	58	630	765	73,5	1 900	2 600	8,70	22224 E	22224 EK
	215	76	610	930	93	1 500	1 900	12,0	23224 CC/W33	23224 CCK/W33
	260	86	965	1 120	100	1 400	1 800	23,0	22324 CC/W33	22324 CCK/W33
130	200	52	430	610	62	1 900	2 600	6,00	23026 CC/W33	23026 CCK/W33
	200	69	540	815	81,5	1 500	1 900	8,05	24026 CC/W33	24026 CCK30/W33
	210	64	489	780	78	1 700	2 200	8,80	23126 CC/W33	23126 CCK/W33
	210	80	587	1 000	100	1 300	1 700	11,0	24126 CC/W33	24126 CCK30/W33
	230	64	735	930	88	1 800	2 400	11,0	22226 E	22226 EK
	230	80	690	1 060	104	1 300	1 700	14,5	23226 CC/W33	23226 CCK/W33
	280	93	1 120	1 320	114	1 300	1 700	29,0	22326 CC/W33	22326 CCK/W33

The designations of Explorer bearings are printed in blue

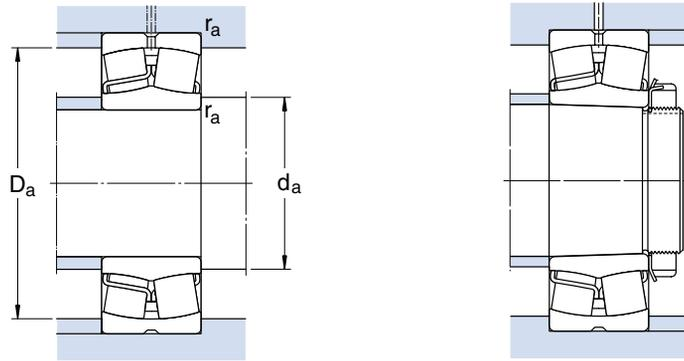

Dimensions

Abutment and fillet dimensions

Calculation factors

d	d ₂	D ₁	b	K	r _{1,2} min	d _a min	D _a max	r _a max	e	Y ₁	Y ₂	Y ₀
mm									-			
85	101	133	5,5	3	2	96	139	2	0,22	3	4,6	2,8
	106	141	5,5	3	3	99	166	2,5	0,24	2,8	4,2	2,8
	108	154	8,3	4,5	3	99	166	2,5	0,33	2	3	2
90	106	141	5,5	3	2	101	149	2	0,24	2,8	4,2	2,8
	106	137	5,5	3	2	101	149	2	0,31	2,2	3,3	2,2
	112	150	8,3	4,5	3	104	176	2,5	0,24	2,8	4,2	2,8
	113	161	11,1	6	3	104	176	2,5	0,33	2	3	2
95	112	150	8,3	4,5	2,1	107	158	2	0,24	2,8	4,2	2,8
	118	159	8,3	4,5	3	109	186	2,5	0,24	2,8	4,2	2,8
	118	168	11,1	6	3	109	186	2,5	0,33	2	3	2
100	111	132	5,5	3	1,5	107	143	1,5	0,28	2,4	3,6	2,5
	115	144	5,5	3	2	111	154	2	0,30	2,3	3,4	2,2
	113	141	5,5	3	2	111	154	2	0,37	1,8	2,7	1,8
	118	159	8,3	4,5	2,1	112	168	2	0,24	2,8	4,2	2,8
	117	153	8,3	4,5	2,1	112	168	2	0,33	2	3	2
	118	159	8,3	4,5	3	114	201	2,5	0,24	2,8	4,2	2,8
	130	184	11,1	6	3	114	201	2,5	0,33	2	3	2
110	125	151	5,5	3	2	120	160	2	0,23	2,9	4,4	2,8
	126	157	8,3	4,5	2	121	169	2	0,30	2,3	3,4	2,2
	123	153	5,5	3	2	121	169	2	0,37	1,8	2,7	1,8
	130	178	8,3	4,5	2,1	122	188	2	0,25	2,7	4	2,5
	130	169	8,3	4,5	2,1	122	188	2	0,33	2	3	2
	143	204	13,9	7,5	3	124	226	2,5	0,33	2	3	2
	120	135	163	5,5	3	2	130	170	2	0,22	3	4,6
132		159	5,5	3	2	130	170	2	0,30	2,3	3,4	2,2
139		174	8,3	4,5	2	131	189	2	0,28	2,4	3,6	2,5
135		168	5,5	3	2	131	189	2	0,37	1,8	2,7	1,8
141		189	11,1	6	2,1	132	203	2	0,26	2,6	3,9	2,5
141		182	8,3	4,5	2,1	132	203	2	0,35	1,9	2,9	1,8
152		216	13,9	7,5	3	134	246	2,5	0,35	1,9	2,9	1,8
130	148	180	8,3	4,5	2	140	190	2	0,23	2,9	4,4	2,8
	145	175	5,5	3	2	140	190	2	0,31	2,2	3,3	2,2
	148	184	8,3	4,5	2	141	199	2	0,28	2,4	3,6	2,5
	146	180	5,5	3	2	141	199	2	0,35	1,9	2,9	1,8
	152	201	11,1	6	3	144	216	2,5	0,27	2,5	3,7	2,5
	151	196	8,3	4,5	3	144	216	2,5	0,33	2	3	2
	164	233	16,7	9	4	148	262	3	0,35	1,9	2,9	1,8

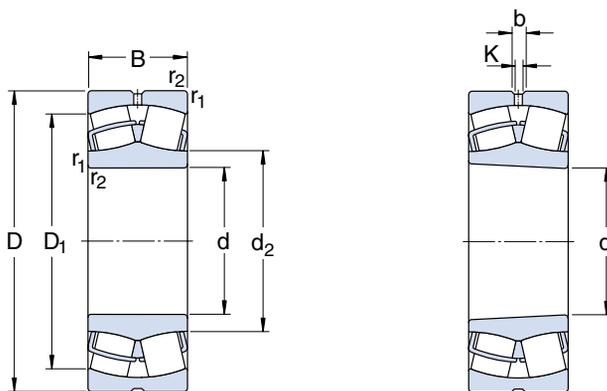

Principal dimensions			Basic load ratings		Fatigue load limit P _u	Speed ratings		Mass	Designations		
d	D	B	dynamic C	static C ₀		Lubrication grease	oil		Bearings with cylindrical bore	tapered bore	
mm			kN		kN	r/min		kg	–		
140	210	53	465	680	68	1 800	2 400	6,55	23028 CC/W33	23028 CCK/W33	
	210	69	570	900	88	1 400	1 800	8,55	24028 CC/W33	24028 CCK30/W33	
	225	68	546	900	88	1 600	2 000	10,5	23128 CC/W33	23128 CCK/W33	
	225	85	673	1 160	112	1 100	1 500	13,5	24128 CC/W33	24128 CCK30/W33	
	250	68	710	900	86,5	1 700	2 200	14,0	22228 CC/W33	22228 CCK/W33	
	250	88	915	1 250	120	1 200	1 600	19,0	23228 CC/W33	23228 CCK/W33	
	300	102	1 290	1 560	132	1 100	1 500	36,5	22328 CC/W33	22328 CCK/W33	
	150	225	56	510	750	73,5	1 700	2 200	7,95	23030 CC/W33	23030 CCK/W33
		225	75	655	1 040	100	1 300	1 700	10,5	24030 CC/W33	24030 CCK30/W33
		250	80	725	1 200	114	1 400	1 800	16,0	23130 CC/W33	23130 CCK/W33
250		100	1 020	1 530	146	1 000	1 400	20,0	24130 CC/W33	24130 CCK30/W33	
270		73	850	1 080	102	1 600	2 000	18,0	22230 CC/W33	22230 CCK/W33	
270		96	1 080	1 460	137	1 100	1 500	24,5	23230 CC/W33	23230 CCK/W33	
320		108	1 460	1 760	146	1 000	1 400	43,5	22330 CC/W33	22330 CCK/W33	
160		240	60	585	880	83	1 700	2 200	9,70	23032 CC/W33	23032 CCK/W33
		240	80	750	1 200	114	1 100	1 500	13,0	24032 CC/W33	24032 CCK30/W33
		270	86	980	1 370	129	1 300	1 700	20,5	23132 CC/W33	23132 CCK/W33
	270	109	1 040	1 760	163	950	1 300	25,0	24132 CC/W33	24132 CCK30/W33	
	290	80	1 000	1 290	118	1 500	1 900	22,5	22232 CC/W33	22232 CCK/W33	
	290	104	1 220	1 660	153	1 000	1 400	31,0	23232 CC/W33	23232 CCK/W33	
	340	114	1 600	1 960	160	950	1 300	52,0	22332 CC/W33	22332 CCK/W33	
	170	260	67	710	1 060	100	1 600	2 000	13,0	23034 CC/W33	23034 CCK/W33
		260	90	930	1 460	137	1 000	1 400	17,5	24034 CC/W33	24034 CCK30/W33
		280	88	1 040	1 500	137	1 200	1 600	22,0	23134 CC/W33	23134 CCK/W33
280		109	1 220	1 860	170	900	1 200	27,5	24134 CC/W33	24134 CCK30/W33	
310		86	1 120	1 460	132	1 300	1 700	28,5	22234 CC/W33	22234 CCK/W33	
310		110	1 400	1 930	173	950	1 300	37,5	23234 CC/W33	23234 CCK/W33	
360		120	1 760	2 160	176	950	1 300	61,0	22334 CC/W33	22334 CCK/W33	
180		250	52	490	830	76,5	1 700	2 200	7,90	23936 CC/W33	–
		280	74	830	1 250	114	1 400	1 800	17,0	23036 CC/W33	23036 CCK/W33
		280	100	937	1 730	156	950	1 300	23,0	24036 CC/W33	24036 CCK30/W33
	300	96	1 200	1 760	160	1 100	1 500	28,0	23136 CC/W33	23136 CCK/W33	
	300	118	1 400	2 160	196	900	1 200	34,5	24136 CC/W33	24136 CCK30/W33	
	320	86	1 180	1 560	140	1 300	1 700	29,5	22236 CC/W33	22236 CCK/W33	
	320	112	1 290	2 120	186	900	1 200	39,5	23236 CC/W33	23236 CCK/W33	
	380	126	2 000	2 450	193	900	1 200	71,5	22336 CC/W33	22336 CCK/W33	

The designations of Explorer bearings are printed in blue

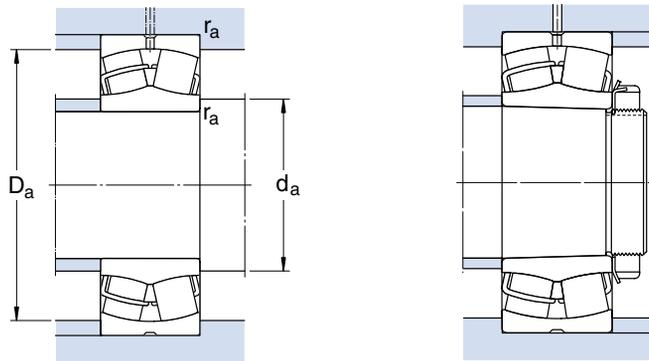

Dimensions

Abutment and fillet dimensions

Calculation factors

d	d ₂	D ₁	b	K	r _{1,2} min	d _a min	D _a max	r _a max	e	Y ₁	Y ₂	Y ₀	
mm					mm			-					
140	158	190	8,3	4,5	2	150	200	2	0,22	3	4,6	2,8	
	155	185	5,5	3	2	150	200	2	0,30	2,3	3,4	2,2	
	159	197	8,3	4,5	2,1	152	213	2	0,28	2,4	3,6	2,5	
	156	193	8,3	4,5	2,1	152	213	2	0,35	1,9	2,9	1,8	
	166	216	11,1	6	3	154	236	2,5	0,26	2,6	3,9	2,5	
	165	212	11,1	6	3	154	236	2,5	0,33	2	3	2	
	175	247	16,7	9	4	157	283	3	0,35	1,9	2,9	1,8	
	150	169	203	8,3	4,5	2,1	161	214	2	0,22	3	4,6	2,8
		165	197	5,5	3	2,1	161	214	2	0,30	2,3	3,4	2,2
172		216	11,1	6	2,1	162	238	2	0,30	2,3	3,4	2,2	
169		211	8,3	4,5	2,1	162	238	2	0,37	1,8	2,7	1,8	
178		234	13,9	7,5	3	164	256	2,5	0,26	2,6	3,9	2,5	
175		228	11,1	6	3	164	256	2,5	0,35	1,9	2,9	1,8	
188		266	16,7	9	4	167	303	3	0,35	1,9	2,9	1,8	
160		180	217	11,1	6	2,1	171	229	2	0,22	3	4,6	2,8
		176	211	8,3	4,5	2,1	171	229	2	0,30	2,3	3,4	2,2
	184	234	13,9	7,5	2,1	172	258	2	0,30	2,3	3,4	2,2	
	181	228	8,3	4,5	2,1	172	258	2	0,40	1,7	2,5	1,6	
	191	250	13,9	7,5	3	174	276	2,5	0,26	2,6	3,9	2,5	
	188	244	13,9	7,5	3	174	276	2,5	0,35	1,9	2,9	1,8	
	200	282	16,7	9	4	177	323	3	0,35	1,9	2,9	1,8	
	170	191	232	11,1	6	2,1	181	249	2	0,23	2,9	4,4	2,8
		188	226	8,3	4,5	2,1	181	249	2	0,33	2	3	2
195		244	13,9	7,5	2,1	182	268	2	0,30	2,3	3,4	2,2	
190		237	8,3	4,5	2,1	182	268	2	0,37	1,8	2,7	1,8	
203		267	16,7	9	4	187	293	3	0,27	2,5	3,7	2,5	
200		261	13,9	7,5	4	187	293	3	0,35	1,9	2,9	1,8	
213		300	16,7	9	4	187	343	3	0,33	2	3	2	
180		199	231	5,5	3	2	190	240	2	0,18	3,8	5,6	3,6
		204	249	13,9	7,5	2,1	191	269	2	0,24	2,8	4,2	2,8
	201	243	8,3	4,5	2,1	191	269	2	0,33	2	3	2	
	207	259	13,9	7,5	3	194	286	2,5	0,30	2,3	3,4	2,2	
	203	253	11,1	6	3	194	286	2,5	0,37	1,8	2,7	1,8	
	213	278	16,7	9	4	197	303	3	0,26	2,6	3,9	2,5	
	211	271	13,9	7,5	4	197	303	3	0,35	1,9	2,9	1,8	
	224	317	22,3	12	4	197	363	3	0,35	1,9	2,9	1,8	

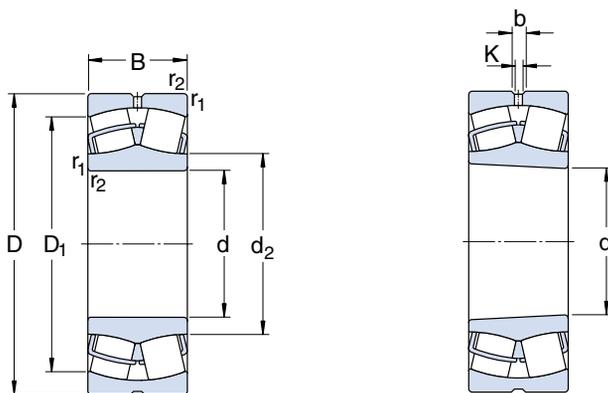

Principal dimensions			Basic load ratings		Fatigue load limit P _u	Speed ratings		Mass	Designations	Bore type	
d	D	B	dynamic C	static C ₀		Lubrication grease	oil				Bearings with cylindrical bore
mm			kN		kN	r/min		kg	–		
190	260	52	475	800	76,5	1 700	2 200	8,30	23938 CC/W33	–	
	290	75	865	1 340	122	1 300	1 700	18,0	23038 CC/W33	23038 CCK/W33	
	290	100	978	1 800	163	950	1 300	24,5	24038 CC/W33	24038 CCK30/W33	
	320	104	1 370	2 080	183	1 000	1 400	35,0	23138 CC/W33	23138 CCK/W33	
	320	128	1 600	2 500	212	850	1 100	43,0	24138 CC/W33	24138 CCK30/W33	
	340	92	1 270	1 700	150	1 200	1 600	36,5	22238 CC/W33	22238 CCK/W33	
	340	120	1 660	2 400	208	850	1 100	48,0	23238 CC/W33	23238 CCK/W33	
	400	132	2 120	2 650	208	850	1 100	82,5	22338 CC/W33	22338 CCK/W33	
	200	280	60	620	1 040	93	1 600	2 000	11,5	23940 CC/W33	–
		310	82	1 000	1 530	137	1 200	1 600	23,3	23040 CC/W33	23040 CCK/W33
310		109	1 130	2 120	186	900	1 200	31,0	24040 CC/W33	24040 CCK30/W33	
340		112	1 600	2 360	204	950	1 300	43,0	23140 CC/W33	23140 CCK/W33	
340		140	1 800	2 800	232	800	1 000	53,5	24140 CC/W33	24140 CCK30/W33	
360		98	1 460	1 930	166	1 100	1 500	43,5	22240 CC/W33	22240 CCK/W33	
360		128	1 860	2 700	228	850	1 100	58,0	23240 CC/W33	23240 CCK/W33	
420		138	2 320	2 900	224	850	1 100	95,0	22340 CC/W33	22340 CCK/W33	
220		300	60	630	1 080	93	1 500	1 900	12,5	23944 CC/W33	–
		340	90	1 220	1 860	163	1 100	1 500	30,5	23044 CC/W33	23044 CCK/W33
	340	118	1 360	2 600	212	850	1 100	40,0	24044 CC/W33	24044 CCK30/W33	
	370	120	1 800	2 750	232	900	1 200	53,5	23144 CC/W33	23144 CCK/W33	
	370	150	2 120	3 350	285	750	950	67,0	24144 CC/W33	24144 CCK30/W33	
	400	108	1 760	2 360	196	950	1 300	60,5	22244 CC/W33	22244 CCK/W33	
	400	144	2 360	3 450	285	750	950	81,5	23244 CC/W33	23244 CCK/W33	
	460	145	2 700	3 450	260	750	950	120	22344 CC/W33	22344 CCK/W33	
	240	320	60	655	1 160	98	1 300	1 700	13,5	23948 CC/W33	–
		360	92	1 290	2 080	176	1 000	1 400	33,5	23048 CC/W33	23048 CCK/W33
360		118	1 380	2 700	228	800	1 000	43,0	24048 CC/W33	24048 CCK30/W33	
400		128	2 080	3 200	255	850	1 100	66,5	23148 CC/W33	23148 CCK/W33	
400		160	2 400	3 900	320	670	850	83,0	24148 CC/W33	24148 CCK30/W33	
440		120	2 200	3 000	245	900	1 200	83,0	22248 CC/W33	22248 CCK/W33	
440		160	2 900	4 300	345	670	850	110	23248 CC/W33	23248 CCK/W33	
500		155	2 670	4 000	290	670	850	155	22348 CC/W33	22348 CCK/W33	
260		360	75	880	1 800	156	1 100	1 500	23,5	23952 CC/W33	–
		400	104	1 600	2 550	212	900	1 200	48,5	23052 CC/W33	23052 CCK/W33
	400	140	2 040	3 450	285	700	900	65,5	24052 CC/W33	24052 CCK30/W33	
	440	144	2 550	3 900	290	800	1 000	90,5	23152 CC/W33	23152 CCK/W33	
	440	180	3 000	4 800	380	600	750	110	24152 CC/W33	24152 CCK30/W33	
	480	130	2 650	3 550	285	850	1 100	110	22252 CC/W33	22252 CCK/W33	
	480	174	3 250	4 750	360	630	800	140	23252 CC/W33	23252 CCK/W33	
	540	165	3 050	4 550	325	630	800	190	22352 CC/W33	22352 CCK/W33	

The designations of Explorer bearings are printed in blue

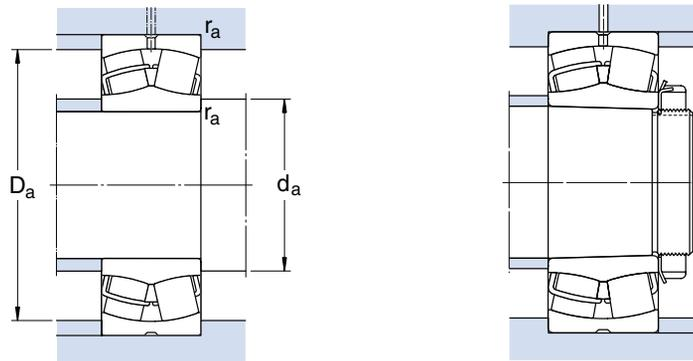

Dimensions

Abutment and fillet dimensions

Calculation factors

d	d ₂	D ₁	b	K	r _{1,2} min	d _a min	D _a max	r _a max	e	Y ₁	Y ₂	Y ₀	
mm						mm			-				
190	209	240	5,5	3	2	200	250	2	0,16	4,2	6,3	4	
	216	261	13,9	7,5	2,1	201	279	2	0,23	2,9	4,4	2,8	
	210	253	8,3	4,5	2,1	201	279	2	0,31	2,2	3,3	2,2	
	220	276	13,9	7,5	3	204	306	2,5	0,31	2,2	3,3	2,2	
	215	268	11,1	6	3	204	306	2,5	0,40	1,7	2,5	1,6	
	225	294	16,7	9	4	207	323	3	0,26	2,6	3,9	2,5	
	222	287	16,7	9	4	207	323	3	0,35	1,9	2,9	1,8	
	236	333	22,3	12	5	210	380	4	0,35	1,9	2,9	1,8	
	200	222	258	8,3	4,5	2,1	211	269	2	0,19	3,6	5,3	3,6
		228	278	13,9	7,5	2,1	211	299	2	0,24	2,8	4,2	2,8
223		268	11,1	6	2,1	211	299	2	0,33	2	3	2	
231		293	16,7	9	3	214	326	2,5	0,31	2,2	3,3	2,2	
226		284	11,1	6	3	214	326	2,5	0,40	1,7	2,5	1,6	
238		313	16,7	9	4	217	343	3	0,26	2,6	3,9	2,5	
235		304	16,7	9	4	217	343	3	0,35	1,9	2,9	1,8	
249		351	22,3	12	5	220	400	4	0,33	2	3	2	
220		241	278	8,3	4,5	2,1	231	289	2	0,16	4,2	6,3	4
		250	306	13,9	7,5	3	233	327	2,5	0,24	2,8	4,2	2,8
	244	295	11,1	6	3	233	327	2,5	0,33	2	3	2	
	255	320	16,7	9	4	237	353	3	0,30	2,3	3,4	2,2	
	248	310	11,1	6	4	237	353	3	0,40	1,7	2,5	1,6	
	263	346	16,7	9	4	237	383	3	0,27	2,5	3,7	2,5	
	259	338	16,7	9	4	237	383	3	0,35	1,9	2,9	1,8	
	279	389	22,3	12	5	240	440	4	0,31	2,2	3,3	2,2	
	240	261	298	8,3	4,5	2,1	251	309	2	0,15	4,5	6,7	4,5
		271	326	13,9	7,5	3	253	347	2,5	0,23	2,9	4,4	2,8
265		316	11,1	6	3	253	347	2,5	0,30	2,3	3,4	2,2	
277		348	16,7	9	4	257	383	3	0,30	2,3	3,4	2,2	
271		336	11,1	6	4	257	383	3	0,40	1,7	2,5	1,6	
290		683	22,3	12	4	257	423	3	0,27	2,5	3,7	2,5	
287		374	22,3	12	4	257	423	3	0,35	1,9	2,9	1,8	
304		422	22,3	12	5	260	480	4	0,31	2,2	3,3	2,2	
260		287	331	8,3	4,5	2,1	271	348	2	0,18	3,8	5,6	3,6
		295	360	16,7	9	4	275	385	3	0,23	2,9	4,4	2,8
	289	347	11,1	6	4	275	385	3	0,33	2	3	2	
	301	380	16,7	9	4	277	423	3	0,31	2,2	3,3	2,2	
	294	368	13,9	7,5	4	277	423	3	0,40	1,7	2,5	1,6	
	311	421	22,3	12	5	280	460	4	0,27	2,5	3,7	2,5	
	312	408	22,3	12	5	280	460	4	0,35	1,9	2,9	1,8	
	329	457	22,3	12	6	286	514	5	0,31	2,2	3,3	2,2	

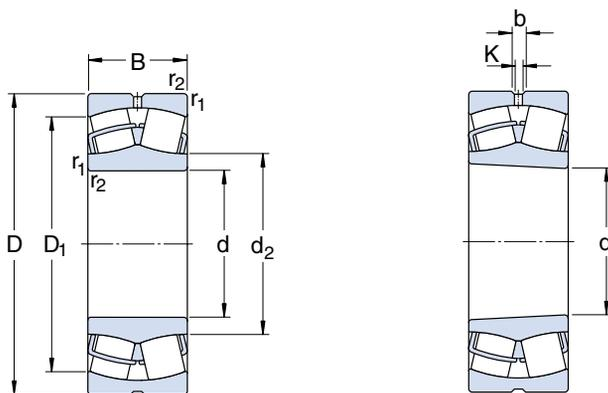

Principal dimensions			Basic load ratings		Fatigue load limit P _u	Speed ratings		Mass	Designations		
d	D	B	dynamic C	static C ₀		Lubrication grease	oil		Bearings with cylindrical bore	tapered bore	
mm			kN		kN	r/min		kg	–		
280	380	75	845	1 760	143	1 000	1 400	25,0	23956 CC/W33	–	
	420	106	1 730	2 850	224	850	1 100	52,5	23056 CC/W33	23056 CCK/W33	
	420	140	2 160	3 800	285	670	850	69,5	24056 CC/W33	24056 CCK30/W33	
	460	146	2 650	4 250	335	750	950	97,0	23156 CC/W33	23156 CCK/W33	
	460	180	3 100	5 100	415	560	700	120	24156 CC/W33	24156 CCK30/W33	
	500	130	2 700	3 750	300	800	1 000	115	22256 CC/W33	22256 CCK/W33	
	500	176	3 250	4 900	365	600	750	150	23256 CC/W33	23256 CCK/W33	
	580	175	3 450	5 200	365	600	750	235	22356 CC/W33	22356 CCK/W33	
	300	380	60	656	1 600	137	1 000	1 400	16,5	23860 CAMA	23860 CAKMA
		420	90	1 200	2 500	200	950	1 300	39,5	23960 CC/W33	23960 CCK/W33
460		118	2 120	3 450	265	800	1 000	71,5	23060 CC/W33	23060 CCK/W33	
460		160	2 700	4 750	355	600	750	97,0	24060 CC/W33	24060 CCK30/W33	
500		160	3 200	5 100	380	670	850	125	23160 CC/W33	23160 CCK/W33	
500		200	3 750	6 300	465	530	670	160	24160 CC/W33	24160 CCK30/W33	
540		140	2 760	4 250	325	750	950	145	22260 CC/W33	22260 CCK/W33	
540		192	3 900	5 850	425	530	670	190	23260 CC/W33	23260 CCK/W33	
320		440	90	1 430	2 700	212	900	1 200	42,0	23964 CC/W33	23964 CCK/W33
		480	121	2 240	3 800	285	800	1 000	78,0	23064 CC/W33	23064 CCK/W33
	480	160	2 850	5 100	400	560	700	100	24064 CC/W33	24064 CCK30/W33	
	540	176	3 750	6 000	440	630	800	165	23164 CC/W33	23164 CCK/W33	
	540	218	3 740	7 100	510	480	600	210	24164 CC/W33	24164 CCK30/W33	
	580	150	3 160	4 900	375	670	850	175	22264 CC/W33	22264 CCK/W33	
	580	208	3 850	6 700	480	500	630	240	23264 CC/W33	23264 CCK/W33	
	340	460	90	1 460	2 800	216	900	1 200	45,5	23968 CC/W33	23968 CCK/W33
		520	133	2 700	4 550	335	700	900	105	23068 CC/W33	23068 CCK/W33
		520	180	3 450	6 200	475	530	670	140	24068 CC/W33	24068 CCK30/W33
580		190	4 250	6 800	480	600	750	210	23168 CC/W33	23168 CCK/W33	
580		243	4 660	8 650	630	450	560	280	24168 ECCJ/W33	24168 ECCK30J/W33	
620		224	4 490	7 800	550	430	530	295	23268 CA/W33	23268 CAK/W33	
360		480	90	1 400	2 750	220	850	1 100	43,0	23972 CC/W33	23972 CCK/W33
		540	134	2 750	4 800	345	670	850	110	23072 CC/W33	23072 CCK/W33
		540	180	3 550	6 550	490	500	630	145	24072 CC/W33	24072 CCK30/W33
		600	192	4 300	6 950	490	560	700	220	23172 CC/W33	23172 CCK/W33
	600	243	4 890	9 300	670	430	530	270	24172 ECCJ/W33	24172 ECCK30J/W33	
	650	170	3 740	6 200	440	480	600	255	22272 CA/W33	22272 CAK/W33	
	650	232	4 660	8 300	570	400	500	335	23272 CA/W33	23272 CAK/W33	

The designations of Explorer bearings are printed in blue

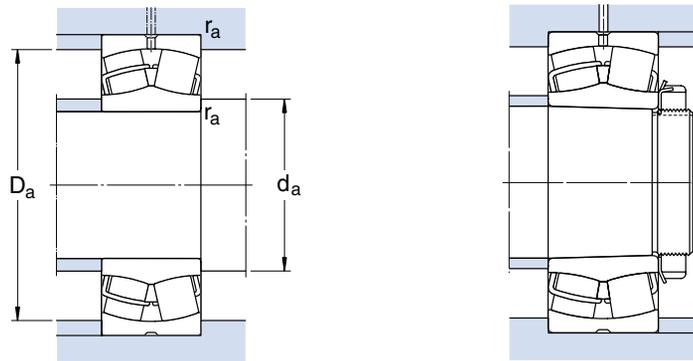

Dimensions

Abutment and fillet dimensions

Calculation factors

d	d ₂	D ₁	b	K	r _{1,2} min	d _a min	D _a max	r _a max	e	Y ₁	Y ₂	Y ₀	
mm						mm			-				
280	308	352	11,1	6	2,1	291	369	2	0,16	4,2	6,3	4	
	315	380	16,7	9	4	295	405	3	0,23	2,9	4,4	2,8	
	309	368	11,1	6	4	295	405	3	0,31	2,2	3,3	2,2	
	321	400	16,7	9	5	300	440	4	0,30	2,3	3,4	2,2	
	315	390	13,9	7,5	5	300	440	4	0,40	1,7	2,5	1,6	
	333	441	22,3	12	5	300	480	4	0,26	2,6	3,9	2,5	
	332	429	22,3	12	5	300	480	4	0,35	1,9	2,9	1,8	
	354	492	22,3	12	6	306	554	5	0,30	2,3	3,4	2,2	
	300	329	358	-	-	2,1	311	369	2	0,13	5,2	7,7	5
		333	385	11,1	6	3	313	407	2,5	0,19	3,6	5,3	3,6
340		413	16,7	9	4	315	445	3	0,23	2,9	4,4	2,8	
331		400	13,9	7,5	4	315	445	3	0,33	2	3	2	
345		434	16,7	9	5	320	480	4	0,30	2,3	3,4	2,2	
339		422	13,9	7,5	5	320	480	4	0,40	1,7	2,5	1,6	
354		477	22,3	12	5	320	520	4	0,26	2,6	3,9	2,5	
356		461	22,3	12	5	320	520	4	0,35	1,9	2,9	1,8	
320		353	405	11,1	6	3	333	427	2,5	0,18	3,8	5,6	3,6
		360	433	16,7	9	4	335	465	3	0,23	2,9	4,4	2,8
	354	423	13,9	7,5	4	335	465	3	0,31	2,2	3,3	2,2	
	370	465	22,3	12	5	340	520	4	0,31	2,2	3,3	2,2	
	364	455	16,7	9	5	340	520	4	0,40	1,7	2,5	1,6	
	379	512	22,3	12	5	340	560	4	0,26	2,6	3,9	2,5	
	382	493	22,3	12	5	340	560	4	0,35	1,9	2,9	1,8	
	340	374	426	11,1	6	3	353	447	2,5	0,17	4	5,9	4
		385	467	22,3	12	5	358	502	4	0,24	2,8	4,2	2,8
		377	453	16,7	9	5	358	502	4	0,33	2	3	2
394		498	22,3	12	5	360	560	4	0,31	2,2	3,3	2,2	
383		488	16,7	9	5	360	560	4	0,40	1,7	2,5	1,6	
426		528	22,3	12	6	366	594	5	0,35	1,9	2,9	1,8	
360		394	447	11,1	6	3	373	467	2,5	0,15	4,5	6,7	4,5
		404	482	22,3	12	5	378	522	4	0,23	2,9	4,4	2,8
		398	474	16,7	9	5	378	522	4	0,31	2,2	3,3	2,2
		418	524	22,3	12	5	380	580	4	0,30	2,3	3,4	2,2
	406	506	16,7	9	5	380	580	4	0,37	1,8	2,7	1,8	
	453	566	22,3	12	6	386	624	5	0,26	2,6	3,9	2,5	
	447	552	22,3	12	6	386	624	5	0,35	1,9	2,9	1,8	

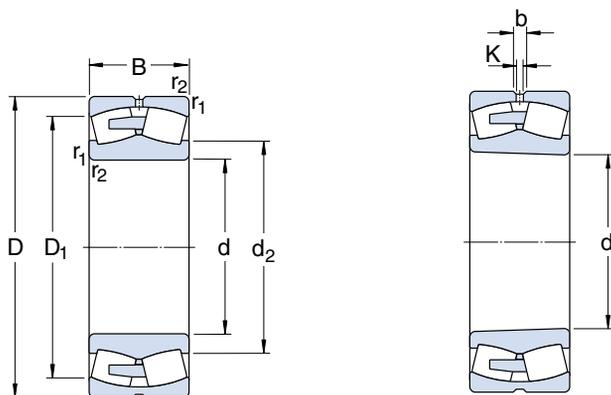

Principal dimensions			Basic load ratings		Fatigue load limit P_u	Speed ratings		Mass kg	Designations	
d	D	B	dynamic C	static C_0		Lubrication grease	oil		Bearings with cylindrical bore	tapered bore
mm			kN		kN	r/min		kg	–	
380	520	106	1 960	3 800	285	800	1 000	69,0	23976 CC/W33	23976 CCK/W33
	560	135	2 900	5 000	360	630	800	115	23076 CC/W33	23076 CCK/W33
	560	180	3 600	6 800	480	480	600	150	24076 CC/W33	24076 CCK30/W33
	620	194	3 740	7 100	500	400	500	230	23176 CA/W33	23176 CAK/W33
	620	243	5 060	9 800	710	340	430	300	24176 ECA/W33	24176 ECAK30/W33
	680	240	5 060	9 150	620	380	480	375	23276 CA/W33	23276 CAK/W33
400	540	106	2 000	3 900	290	750	950	71,0	23980 CC/W33	23980 CCK/W33
	600	148	3 250	5 700	400	600	750	150	23080 CC/W33	23080 CCK/W33
	600	200	4 300	8 000	560	450	560	205	24080 ECCJ/W33	24080 ECCK30J/W33
	650	200	4 080	7 650	530	380	480	265	23180 CA/W33	23180 CAK/W33
	650	250	5 350	10 600	735	320	400	340	24180 ECA/W33	24180 ECAK30/W33
	720	256	5 750	10 400	680	340	430	450	23280 CA/W33	23280 CAK/W33
420	820	243	6 560	10 400	670	360	450	650	22380 CA/W33	22380 CAK/W33
	560	106	2 040	4 150	300	700	900	74,5	23984 CC/W33	23984 CCK/W33
	620	150	2 990	6 000	415	450	560	155	23084 CA/W33	23084 CAK/W33
	620	200	3 850	8 300	585	380	480	210	24084 ECA/W33	24084 ECAK30/W33
	700	224	4 890	9 300	620	360	450	350	23184 CJ/W33	23184 CKJ/W33
	700	280	6 330	12 600	850	300	380	445	24184 ECA/W33	24184 ECAK30/W33
440	760	272	6 330	11 600	765	320	400	535	23284 CA/W33	23284 CAK/W33
	600	118	2 450	4 900	345	670	850	99,5	23988 CC/W33	23988 CCK/W33
	650	157	3 220	6 550	450	430	530	180	23088 CA/W33	23088 CAK/W33
	650	212	4 140	9 150	630	360	450	245	24088 ECA/W33	24088 ECAK30/W33
	720	226	5 180	10 000	670	340	430	360	23188 CA/W33	23188 CAK/W33
	720	280	6 560	13 200	900	280	360	460	24188 ECA/W33	24188 ECAK30/W33
460	790	280	6 730	12 500	800	320	400	590	23288 CA/W33	23288 CAK/W33
	580	118	1 790	4 900	345	450	560	75,5	24892 CAMA/W20	24892 CAK30MA/W20
	620	118	2 190	5 000	355	430	530	105	23992 CA/W33	23992 CAK/W33
	680	163	3 450	6 950	465	400	500	205	23092 CA/W33	23092 CAK/W33
	680	218	4 490	10 000	670	340	430	275	24092 ECA/W33	24092 ECAK30/W33
	760	240	5 640	10 800	680	320	400	440	23192 CA/W33	23192 CAK/W33
480	760	300	7 250	14 600	1 000	260	340	560	24192 ECA/W33	24192 ECAK30/W33
	830	296	7 360	13 700	880	300	380	695	23292 CA/W33	23292 CAK/W33
	600	90	1 440	3 750	280	430	530	61,0	23896 CAMA/W20	23896 CAKMA/W20
	650	128	2 530	5 700	405	400	500	125	23996 CA/W33	23996 CAK/W33
	700	165	3 340	6 800	450	380	480	215	23096 CA/W33	23096 CAK/W33
	700	218	4 600	10 400	695	340	430	285	24096 ECA/W33	24096 ECAK30/W33
480	790	248	6 100	12 000	780	300	380	485	23196 CA/W33	23196 CAK/W33
	790	308	7 710	15 600	1 040	240	320	605	24196 ECA/W33	24196 ECAK30/W33
	870	310	8 170	15 000	950	260	340	800	23296 CA/W33	23296 CAK/W33

The designations of Explorer bearings are printed in blue

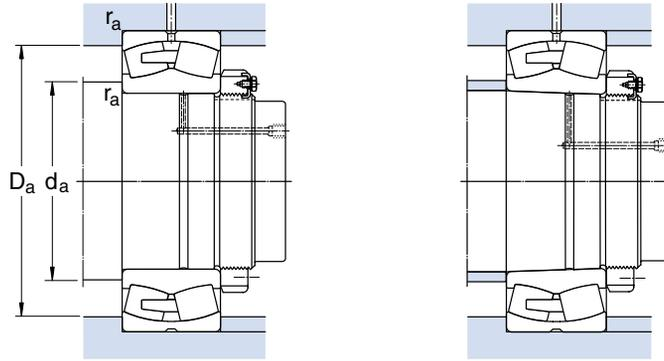

Dimensions

Abutment and fillet dimensions

Calculation factors

d	d ₂	D ₁	b	K	r _{1,2} min	d _a min	D _a max	r _a max	e	Y ₁	Y ₂	Y ₀
mm						mm			-			
380	420	481	13,9	7,5	4	395	505	3	0,17	4	5,9	4
	425	508	22,3	12	5	398	542	4	0,22	3	4,6	2,8
	420	496	16,7	9	5	398	542	4	0,30	2,3	3,4	2,2
	452	541	22,3	12	5	400	600	4	0,30	2,3	3,4	2,2
	446	529	16,7	9	5	400	600	4	0,37	1,8	2,7	1,8
	471	581	22,3	12	6	406	654	5	0,35	1,9	2,9	1,8
400	438	500	13,9	7,5	4	415	525	3	0,17	4	5,9	4
	450	543	22,3	12	5	418	582	4	0,23	2,9	4,4	2,8
	442	527	22,3	12	5	418	582	4	0,30	2,3	3,4	2,2
	474	566	22,3	12	6	426	624	5	0,28	2,4	3,6	2,5
	468	554	22,3	12	6	426	624	5	0,37	1,8	2,7	1,8
	499	615	22,3	12	6	426	694	5	0,35	1,9	2,9	1,8
534	697	22,3	12	7,5	432	788	6	0,30	2,3	3,4	2,2	
420	459	519	16,7	9	4	435	545	3	0,16	4,2	6,3	4
	485	562	22,3	12	5	438	602	4	0,22	3	4,6	2,8
	476	547	22,3	12	5	438	602	4	0,30	2,3	3,4	2,2
	483	607	22,3	12	6	446	674	5	0,30	2,3	3,4	2,2
	496	590	22,3	12	6	446	674	5	0,37	1,8	2,7	1,8
	525	649	22,3	12	7,5	452	728	6	0,35	1,9	2,9	1,8
440	484	552	16,7	9	4	455	585	3	0,17	4	5,9	4
	509	589	22,3	12	6	463	627	5	0,22	3	4,6	2,8
	498	572	22,3	12	6	463	627	5	0,30	2,3	3,4	2,2
	528	632	22,3	12	6	466	694	5	0,30	2,3	3,4	2,2
	516	610	22,3	12	6	466	694	5	0,37	1,8	2,7	1,8
	547	676	22,3	12	7,5	472	758	6	0,35	1,9	2,9	1,8
460	505	541	-	6	3	473	567	2,5	0,17	4	5,9	3,7
	512	573	16,7	9	4	475	605	3	0,16	4,2	6,3	4
	531	616	22,3	12	6	483	657	5	0,22	3	4,6	2,8
	523	601	22,3	12	6	483	657	5	0,28	2,4	3,6	2,5
	553	665	22,3	12	7,5	492	728	6	0,30	2,3	3,4	2,2
	544	649	22,3	12	7,5	492	728	6	0,37	1,8	2,7	1,8
572	706	22,3	12	7,5	492	798	6	0,35	1,9	2,9	1,8	
480	521	566	-	7,5	3	493	587	2,5	0,13	5,2	7,7	5
	532	601	16,7	9	5	498	632	4	0,18	3,8	5,6	3,6
	547	632	22,3	12	6	503	677	5	0,21	3,2	4,8	3,2
	541	619	22,3	12	6	503	677	5	0,28	2,4	3,6	2,5
	577	692	22,3	12	7,5	512	758	6	0,30	2,3	3,4	2,2
	564	678	22,3	12	7,5	512	758	6	0,37	1,8	2,7	1,8
600	741	22,3	12	7,5	512	838	6	0,35	1,9	2,9	1,8	

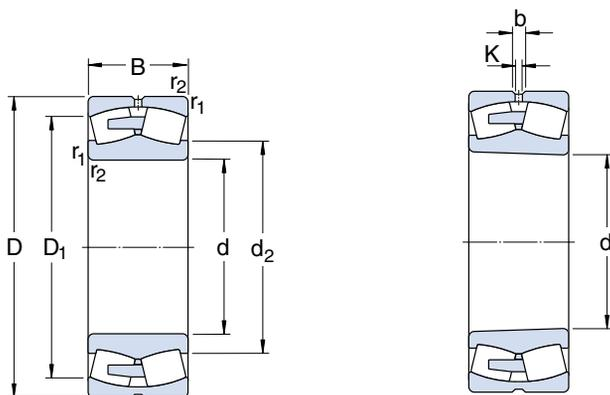

Principal dimensions			Basic load ratings		Fatigue load limit	Speed ratings		Mass	Designations	
d	D	B	dynamic C	static C ₀	P _u	Lubrication grease	oil	kg	Bearings with cylindrical bore	tapered bore
mm			kN		kN		r/min		–	
500	620	90	1 480	4 000	290	430	530	62,0	238/500 CAMA/W20	238/500 CAKMA/W20
	670	128	2 530	6 000	415	400	500	130	239/500 CA/W33	239/500 CAK/W33
	720	167	3 680	7 800	510	380	480	225	230/500 CA/W33	230/500 CAK/W33
	720	218	4 770	11 000	735	320	400	295	240/500 ECA/W33	240/500 ECAK30/W33
	830	264	6 730	12 900	830	280	360	580	231/500 CA/W33	231/500 CAK/W33
	830	325	8 630	17 000	1 120	220	300	745	241/500 ECA/W33	241/500 ECAK30/W33
	920	336	9 370	17 300	1 120	240	320	985	232/500 CA/W33	232/500 CAK/W33
	870	272	7 130	14 000	915	260	340	645	231/530 CA/W33	231/530 CAK/W33
	870	335	9 200	19 000	1 220	200	280	830	241/530 ECA/W33	241/530 ECAK30/W33
	980	355	11 100	20 400	1 220	220	300	1 200	232/530 CA/W33	232/530 CAK/W33
530	650	118	1 840	5 300	380	380	480	86,0	248/530 CAMA/W20	248/530 CAK30MA/W20
	710	136	2 820	6 700	480	360	450	155	239/530 CA/W33	239/530 CAK/W33
	780	185	4 370	9 300	630	340	430	310	230/530 CA/W33	230/530 CAK/W33
	780	250	5 750	13 200	830	280	360	410	240/530 ECA/W33	240/530 ECAK30/W33
	870	272	7 130	14 000	915	260	340	645	231/530 CA/W33	231/530 CAK/W33
	870	335	9 200	19 000	1 220	200	280	830	241/530 ECA/W33	241/530 ECAK30/W33
	980	355	11 100	20 400	1 220	220	300	1 200	232/530 CA/W33	232/530 CAK/W33
	820	195	4 890	10 200	680	320	400	355	230/560 CA/W33	230/560 CAK/W33
	820	258	6 330	14 600	960	260	340	465	240/560 ECA/W33	240/560 ECAK30/W33
	920	280	7 990	16 000	980	240	320	740	231/560 CA/W33	231/560 CAK/W33
560	920	355	10 500	21 600	1 340	190	260	985	241/560 ECJ/W33	241/560 ECK30J/W33
	1 030	365	11 500	22 000	1 400	200	280	1 350	232/560 CA/W33	232/560 CAK/W33
	800	150	3 450	8 300	585	320	400	220	239/600 CA/W33	239/600 CAK/W33
	870	200	5 230	11 400	750	300	380	405	230/600 CA/W33	230/600 CAK/W33
	870	272	7 130	17 000	1 100	240	320	520	240/600 ECAF/W33	240/600 ECAK30F/W33
	980	300	8 970	18 000	1 140	200	280	895	231/600 CA/W33	231/600 CAK/W33
	980	375	11 500	23 600	1 460	180	240	1 200	241/600 ECA/W33	241/600 ECAK30/W33
	1 090	388	13 100	25 500	1 560	190	260	1 600	232/600 CA/W33	232/600 CAK/W33
	780	112	2 190	6 100	415	320	400	120	238/630 CAMA/W20	238/630 CAKMA/W20
	630	850	165	3 970	9 800	640	280	360	280	239/630 CA/W33
920		212	5 750	12 500	800	260	340	485	230/630 CA/W33	230/630 CAK/W33
920		290	7 710	18 000	1 140	220	300	645	240/630 ECJ/W33	240/630 ECK30J/W33
1 030		315	10 500	20 800	1 220	190	260	1 050	231/630 CA/W33	231/630 CAK/W33
1 030		400	12 700	27 000	1 630	170	220	1 400	241/630 ECA/W33	241/630 ECAK30/W33
820		112	2 250	6 400	440	280	360	130	238/670 CAMA/W20	238/670/ CAKMA/W20
820		150	3 110	9 500	655	280	360	172	248/670 CAMA/W20	–
900		170	4 370	10 800	695	260	340	315	239/670 CA/W33	239/670 CAK/W33
980		230	6 560	14 600	915	240	320	600	230/670 CA/W33	230/670 CAK/W33
980		308	8 630	20 400	1 320	200	280	790	240/670 ECA/W33	240/670 ECAK30/W33
670	1 090	336	10 900	22 400	1 370	180	240	1 250	231/670 CA/W33	231/670 CAK/W33
	1 090	412	13 800	29 000	1 760	160	200	1 600	241/670 ECA/W33	241/670 ECAK30/W33
	1 220	438	15 400	30 500	1 700	170	220	2 270	232/670 CA/W33	232/670 CAK/W33

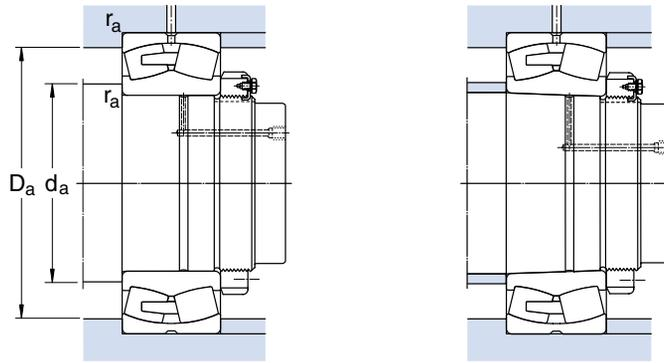

Dimensions

Abutment and fillet dimensions

Calculation factors

d	d ₂	D ₁	b	K	r _{1,2} min	d _a min	D _a max	r _a max	e	Y ₁	Y ₂	Y ₀
mm						mm			—			
500	543	587	—	7,5	3	513	607	2,5	0,12	5,6	8,4	5,6
	557	621	22,3	12	5	518	652	4	0,17	4	5,9	4
	571	656	22,3	12	6	523	697	5	0,21	3,2	4,8	3,2
	565	643	22,3	12	6	523	697	5	0,26	2,6	3,9	2,5
	603	726	22,3	12	7,5	532	798	6	0,30	2,3	3,4	2,2
	589	713	22,3	12	7,5	532	798	6	0,37	1,8	2,7	1,8
	631	779	22,3	12	7,5	532	888	6	0,35	1,9	2,9	1,8
	530	573	612	—	7,5	3	543	637	2,5	0,15	4,5	6,7
589		659	22,3	12	5	548	692	4	0,17	4	5,9	4
611		708	22,3	12	6	553	757	5	0,22	3	4,6	2,8
600		687	22,3	12	6	553	757	5	0,28	2,4	3,6	2,5
636		763	22,3	12	7,5	562	838	6	0,30	2,3	3,4	2,2
623		748	22,3	12	7,5	562	838	6	0,37	1,8	2,7	1,8
668		836	22,3	12	9,5	570	940	8	0,35	1,9	2,9	1,8
560		625	695	22,3	12	5	578	732	4	0,16	4,2	6,3
	644	745	22,3	12	6	583	797	5	0,22	3	4,6	2,8
	635	728	22,3	12	6	583	797	5	0,28	2,4	3,6	2,5
	673	808	22,3	12	7,5	592	888	6	0,30	2,3	3,4	2,2
	634	796	22,3	12	7,5	592	888	6	0,37	1,8	2,7	1,8
	704	877	22,3	12	9,5	600	990	8	0,35	1,9	2,9	1,8
	600	668	742	22,3	12	5	618	782	4	0,17	4	5,9
683		786	22,3	12	6	623	847	5	0,22	3	4,6	2,8
675		774	22,3	12	6	623	847	5	0,30	2,3	3,4	2,2
720		862	22,3	12	7,5	632	948	6	0,30	2,3	3,4	2,2
702		845	22,3	12	7,5	632	948	6	0,35	1,9	2,9	1,8
752		928	22,3	12	9,5	640	1 050	8	0,37	1,8	2,7	1,8
630		681	738	—	9	4	645	765	3	0,12	5,6	8,4
	705	786	22,3	12	6	653	827	5	0,17	4	5,9	4
	725	837	22,3	12	7,5	658	892	6	0,21	3,2	4,8	3,2
	697	823	22,3	12	7,5	658	892	6	0,28	2,4	3,6	2,5
	757	908	22,3	12	7,5	662	998	6	0,30	2,3	3,4	2,2
	738	885	22,3	12	7,5	662	998	6	0,37	1,8	2,7	1,8
	670	720	778	—	9	4	685	805	3	0,11	6,1	9,1
718		786	—	9	4	685	805	3	0,16	4,2	6,3	4
749		834	22,3	12	6	693	877	5	0,17	4	5,9	4
770		890	22,3	12	7,5	698	952	6	0,21	3,2	4,8	3,2
756		866	22,3	12	7,5	698	952	6	0,28	2,4	3,6	2,5
802		958	22,3	12	7,5	702	1 058	6	0,30	2,3	3,4	2,2
782		942	22,3	12	7,5	702	1 058	6	0,37	1,8	2,7	1,8
830		1 027	22,3	12	12	718	1 172	10	0,35	1,9	2,9	1,8

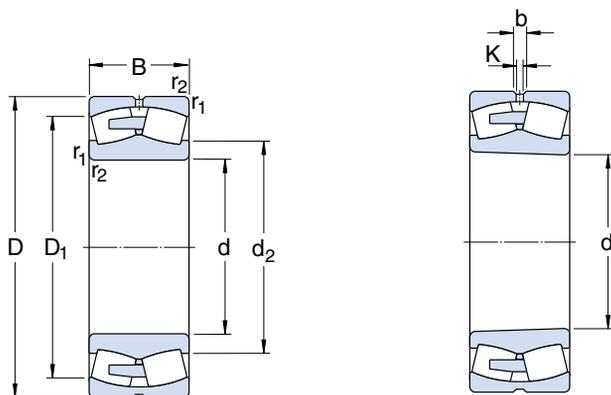

Principal dimensions			Basic load ratings		Fatigue load limit P_u	Speed ratings		Mass	Designations	
d	D	B	dynamic C	static C_0		Lubrication grease	oil		Bearings with cylindrical bore	tapered bore
mm			kN		kN	r/min		kg	–	
710	870	118	2 580	7 500	500	260	340	153	238/710 CAMA/W20	–
	950	180	4 770	12 000	765	240	320	365	239/710 CA/W33	239/710 CAK/W33
	950	243	5 870	15 600	930	200	280	495	249/710 CA/W33	249/710 CAK30/W33
	1 030	236	7 250	16 300	1 000	220	300	670	230/710 CA/W33	230/710 CAK/W33
	1 030	315	9 370	22 800	1 370	190	260	895	240/710 ECA/W33	240/710 ECAK30/W33
	1 150	345	12 200	26 000	1 530	180	240	1 450	231/710 CA/W33	231/710 CAK/W33
	1 150	438	15 200	32 500	1 900	150	190	1 900	241/710 ECA/W33	241/710 ECAK30/W33
	1 280	450	17 600	34 500	2 000	160	200	1 450	232/710 CA/W33	232/710 CAK/W33
750	920	128	2 930	8 500	550	240	320	135	238/750 CAMA/W20	238/750 CAKMA/W20
	1 000	185	5 180	13 200	815	220	300	420	239/750 CA/W33	239/750 CAK/W33
	1 000	250	6 560	18 000	1 100	190	260	560	249/750 CA/W33	249/750 CAK30/W33
	1 090	250	8 450	18 600	1 100	200	280	795	230/750 CA/W33	230/750 CAK/W33
	1 090	335	10 100	25 000	1 460	180	240	1 065	240/750 ECA/W33	240/750 ECAK30/W33
	1 220	365	13 800	29 000	1 700	170	220	1 700	231/750 CA/W33	231/750 CAK/W33
	1 220	475	17 300	37 500	2 160	140	180	2 100	241/750 ECA/W33	241/750 ECAK30/W33
	1 360	475	18 700	36 500	2 120	150	190	3 050	232/750 CAF/W33	232/750 CAKF/W33
800	980	180	4 140	12 900	830	180	240	300	248/800 CAMA/W20	248/800 CAK30MA/W20
	1 060	195	5 640	14 300	880	200	280	470	239/800 CA/W33	239/800 CAK/W33
	1 060	258	7 020	19 300	1 060	180	240	640	249/800 CA/W33	249/800 CAK30/W33
	1 150	258	8 630	20 000	1 160	190	260	895	230/800 CA/W33	230/800 CAK/W33
	1 150	345	11 100	28 500	1 730	170	220	1 200	240/800 ECA/W33	240/800 ECAK30/W33
	1 280	375	14 800	31 500	1 800	160	200	1 920	231/800 CA/W33	231/800 CAK/W33
	1 280	475	18 400	40 500	2 320	130	170	2 300	241/800 ECA/W33	241/800 ECAK30/W33
850	1 030	136	3 340	10 000	640	190	260	240	238/850 CAMA/W20	238/850 CAKMA/W20
	1 120	200	5 980	15 600	930	190	260	560	239/850 CA/W33	239/850 CAK/W33
	1 120	272	8 170	22 800	1 370	170	220	740	249/850 CA/W33	249/850 CAK30/W33
	1 220	272	9 370	21 600	1 270	180	240	1 050	230/850 CA/W33	230/850 CAK/W33
	1 220	365	12 700	31 500	1 900	160	200	1 410	240/850 ECA/W33	240/850 ECAK30/W33
	1 360	400	16 100	34 500	2 000	140	180	2 200	231/850 CA/W33	231/850 CAK/W33
	1 360	500	20 200	45 000	2 550	110	150	2 710	241/850 ECAF/W33	241/850 ECAK30F/W33
900	1 090	190	4 660	15 300	950	170	220	370	248/900 CAMA/W20	248/900 CAK30MA/W20
	1 180	206	6 440	17 000	1 020	180	240	605	239/900 CA/W33	239/900 CAK/W33
	1 280	280	10 100	23 200	1 340	170	220	1 200	230/900 CA/W33	230/900 CAK/W33
	1 280	375	13 600	34 500	2 040	150	190	1 570	240/900 ECA/W33	240/900 ECAK30/W33
	1 420	515	21 400	49 000	2 700	100	140	3 350	241/900 ECAF/W33	241/900 ECAK30F/W33
950	1 250	224	7 250	19 600	1 120	170	220	755	239/950 CA/W33	239/950 CAK/W33
	1 250	300	9 200	26 000	1 500	140	180	1 015	249/950 CA/W33	249/950 CAK30/W33
	1 360	300	12 000	28 500	1 600	160	200	1 450	230/950 CA/W33	230/950 CAK/W33
	1 360	412	14 800	39 000	2 320	130	170	1 990	240/950 CAF/W33	240/950 CAK30F/W33
	1 500	545	23 900	55 000	3 000	95	130	3 535	241/950 ECAF/W33	241/950 ECAK30F/W33

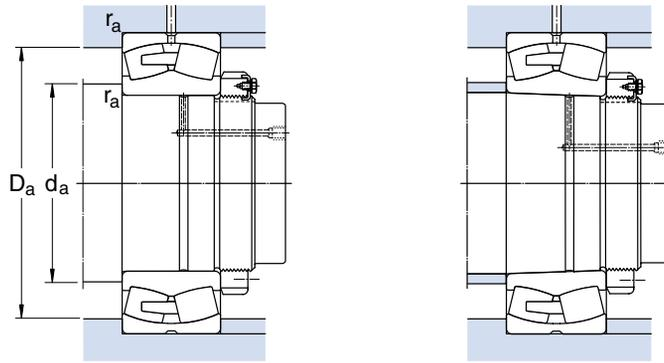

Dimensions

Abutment and fillet dimensions

Calculation factors

d	d ₂	D ₁	b	K	r _{1,2} min	d _a min	D _a max	r _a max	e	Y ₁	Y ₂	Y ₀
mm						mm			—			
710	762	834	—	12	4	725	855	3	0,11	6,1	9,1	6,3
	788	881	22,3	12	6	732	927	5	0,17	4	5,9	4
	792	868	22,3	12	6	732	927	5	0,22	3	4,6	2,8
	814	939	22,3	12	7,5	738	1 002	6	0,21	3,2	4,8	3,2
	807	917	22,3	12	7,5	738	1 002	6	0,27	2,5	3,7	2,5
	850	1 017	22,3	12	9,5	750	1 110	8	0,28	2,4	3,6	2,5
	838	982	22,3	12	9,5	750	1 110	8	0,37	1,8	2,7	1,8
	851	1 017	22,3	12	12	758	1 232	10	0,35	1,9	2,9	1,8
750	807	873	—	12	5	768	902	4	0,11	6,1	9,1	6,3
	832	929	22,3	12	6	773	977	5	0,16	4,2	6,3	4
	830	916	22,3	12	6	773	977	5	0,22	3	4,6	3,2
	860	996	22,3	12	7,5	778	1 062	6	0,21	3,2	4,8	3,2
	853	969	22,3	12	7,5	778	1 062	6	0,28	2,4	3,6	2,5
	900	1 080	22,3	12	9,5	790	1 180	8	0,28	2,4	3,6	2,5
	875	1 050	22,3	12	9,5	790	1 180	8	0,37	1,8	2,7	1,8
	938	1 163	22,3	12	15	808	1 302	12	0,35	1,9	2,9	1,8
800	865	921	—	12	5	818	962	4	0,15	4,5	6,7	4,5
	885	984	22,3	12	6	823	1 037	5	0,16	4,2	6,3	4
	883	973	22,3	12	6	823	1 037	5	0,21	3,2	4,8	3,2
	915	1 051	22,3	12	7,5	828	1 122	6	0,20	3,4	5	3,2
	908	1 027	22,3	12	7,5	828	1 122	6	0,27	2,5	3,7	2,5
	950	1 141	22,3	12	9,5	840	1 240	8	0,28	2,4	3,6	2,5
	930	1 111	22,3	12	9,5	840	1 240	8	0,35	1,9	2,9	1,8
	850	910	981	—	12	5	868	1 012	4	0,11	6,1	9,1
940		1 043	22,3	12	6	873	1 097	5	0,16	4,2	6,3	4
948		1 028	22,3	12	6	873	1 097	5	0,22	3	4,6	2,8
969		1 114	22,3	12	7,5	878	1 192	6	0,20	3,4	5	3,2
954		1 087	22,3	12	7,5	878	1 192	6	0,27	2,5	3,7	2,5
	1 010	1 203	22,3	12	12	898	1 312	10	0,28	2,4	3,6	2,5
	988	1 182	22,3	12	12	898	1 312	10	0,35	1,9	2,9	1,8
900	969	1 029	—	12	5	918	1 072	4	0,14	4,8	7,2	4,5
	989	1 100	22,3	12	6	923	1 157	5	0,15	4,5	6,7	4,5
	1 023	1 177	22,3	12	7,5	928	1 252	6	0,20	3,4	5	3,2
	1 012	1 147	22,3	12	7,5	928	1 252	6	0,26	2,6	3,9	2,5
	1 043	1 235	22,3	12	12	948	1 372	10	0,35	1,9	2,9	1,8
950	1 049	1 161	22,3	12	7,5	978	1 222	6	0,15	4,5	6,7	4,5
	1 051	1 150	22,3	12	7,5	978	1 222	6	0,21	3,2	4,8	3,2
	1 083	1 242	22,3	12	7,5	978	1 332	6	0,20	3,4	5	3,2
	1 074	1 212	22,3	12	7,5	978	1 332	6	0,27	2,5	3,7	2,5
	1 102	1 305	22,3	12	12	998	1 452	10	0,35	1,9	2,9	1,8

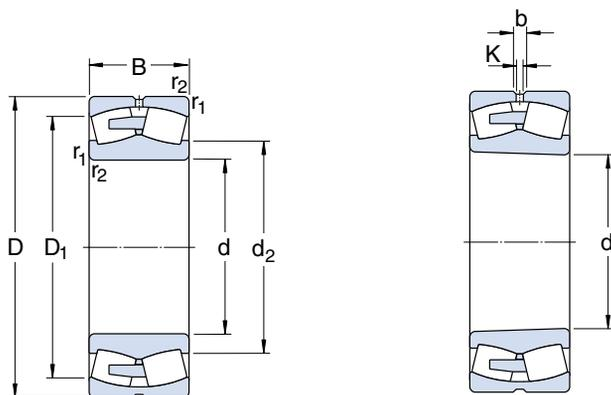

Principal dimensions			Basic load ratings		Fatigue load limit P_u	Speed ratings		Mass kg	Designations	
d	D	B	dynamic C	static C_0		Lubrication grease	oil		Bearings with cylindrical bore	tapered bore
mm			kN		kN	r/min		kg	–	
1 000	1 220	165	4 660	14 300	865	170	220	410	238/1000 CAMA/W20	238/1000 CAKMA/W20
	1 320	315	10 400	29 000	1 500	130	170	1 200	249/1000 CA/W33	249/1000 CAK30/W33
	1 420	308	12 700	30 500	1 700	140	180	1 600	230/1000 CAF/W33	230/1000 CAKF/W33
	1 420	412	15 400	40 500	2 240	120	160	2 140	240/1000 CAF/W33	240/1000 CAK30F/W33
	1 580	462	21 400	48 000	2 550	100	140	3 500	231/1000 CAF/W33	231/1000 CAKF/W33
	1 580	580	26 700	62 000	3 350	90	120	4 300	241/1000 ECAF/W33	241/1000 ECAK30F/W33
1 060	1 280	165	4 770	15 000	800	160	200	435	238/1060 CAMA/W20	238/1060 CAKMA/W20
	1 280	218	6 100	20 000	1 200	130	170	570	248/1060 CAMA/W20	248/1060 CAK30MA/W20
	1 400	250	9 550	26 000	1 460	140	180	1 100	239/1060 CAF/W33	239/1060 CAKF/W33
	1 400	335	11 500	32 500	1 860	120	160	1 400	249/1060 CAF/W33	249/1060 CAK30F/W33
	1 500	325	13 800	34 000	1 830	130	170	2 250	230/1060 CAF/W33	230/1060 CAKF/W33
	1 500	438	17 300	45 500	2 500	110	150	2 515	240/1060 CAF/W33	240/1060 CAK30F/W33
1 120	1 360	243	7 250	24 000	1 400	110	150	735	248/1120 CAFA/W20	248/1120 CAK30FA/W20
	1 460	335	11 700	34 500	1 830	100	140	1 500	249/1120 CAF/W33	249/1120 CAK30F/W33
	1 580	462	18 700	50 000	2 850	95	130	2 925	240/1120 CAF/W33	240/1120 CAK30F/W33
1 180	1 420	180	5 870	18 600	1 080	130	170	575	238/1180 CAFA/W20	238/1180 CAKFA/W20
	1 420	243	7 710	27 000	1 560	130	170	770	248/1180 CAFA/W20	248/1180 CAK30FA/W20
	1 540	272	11 100	31 000	1 660	110	150	1 400	239/1180 CAF/W33	239/1180 CAKF/W33
	1 540	355	13 600	40 500	2 160	95	130	1 800	249/1180 CAF/W33	249/1180 CAK30F/W33
1 250	1 750	375	17 900	45 000	2 400	95	130	2 840	230/1250 CAF/W33	230/1250 CAKF/W33
1 320	1 600	280	9 780	33 500	1 860	90	120	1 160	248/1320 CAFA/W20	248/1320 CAK30FA/W20
	1 720	400	16 100	49 000	2 550	85	110	2 500	249/1320 CAF/W33	249/1320 CAK30F/W33
1 500	1 820	315	12 700	45 000	2 400	85	110	1 710	248/1500 CAFA/W20	248/1500 CAK30FA/W20
	1 950	450	20 700	63 000	3 150	67	85	3 550	249/1500 CAFB/W33	249/1500 CAK30FB/W33
1 800	2 180	375	17 600	63 000	3 050	60	75	2 900	248/1800 CAFA/W20	248/1800 CAK30FA/W20

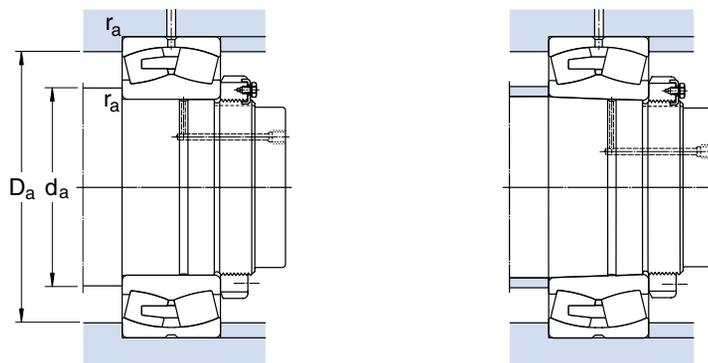

Dimensions

Abutment and fillet dimensions

Calculation factors

d	d ₂	D ₁	b	K	r _{1,2} min	d _a min	D _a max	r _a max	e	Y ₁	Y ₂	Y ₀
mm					mm				-			
1 000	1 077	1 161	-	12	6	1 023	1 197	5	0,12	5,6	8,4	5,6
	1 106	1 209	22,3	12	7,5	1 028	1 292	6	0,21	3,2	4,8	3,2
	1 139	1 305	22,3	12	7,5	1 028	1 392	6	0,19	3,6	5,3	3,6
	1 133	1 275	22,3	12	7,5	1 028	1 392	6	0,26	2,6	3,9	2,5
	1 182	1 399	22,3	12	12	1 048	1 532	10	0,28	2,4	3,6	2,5
	1 159	1 373	22,3	12	12	1 048	1 532	10	0,35	1,9	2,9	1,8
1 060	1 135	1 219	-	12	6	1 083	1 257	5	0,11	6,1	9,1	6,3
	1 159	1 210	-	12	6	1 083	1 257	5	0,14	4,8	7,2	4,5
	1 171	1 303	22,3	12	7,5	1 088	1 392	6	0,16	4,2	6,3	4
	1 165	1 282	22,3	12	7,5	1 088	1 392	6	0,21	3,2	4,8	3,2
	1 202	1 373	22,3	12	9,5	1 094	1 466	8	0,19	3,6	5,3	3,6
	1 196	1 347	22,3	12	9,5	1 094	1 466	8	0,26	2,6	3,9	2,5
1 120	1 207	1 282	-	12	6	1 143	1 337	5	0,15	4,5	6,7	4,5
	1 230	1 349	22,3	12	7,5	1 148	1 432	6	0,20	3,4	5	3,2
	1 266	1 422	22,3	12	9,5	1 154	1 546	8	0,26	2,6	3,9	2,5
1 180	1 261	1 355	-	12	6	1 203	1 397	5	0,11	6,1	9,1	6,3
	1 280	1 343	-	12	6	1 203	1 397	5	0,14	4,8	7,2	4,5
	1 298	1 435	22,3	12	7,5	1 208	1 512	6	0,16	4,2	6,3	4
	1 293	1 417	22,3	12	7,5	1 208	1 512	6	0,20	3,4	5	3,2
1 250	1 411	1 607	22,3	12	9,5	1 284	1 716	8	0,19	3,6	5,3	3,6
	1 422	1 511	-	12	6	1 343	1 577	5	0,15	4,5	6,7	4,5
1 320	1 445	1 584	22,3	12	7,5	1 348	1 692	6	0,21	3,2	4,8	3,2
	1 612	1 719	-	12	7,5	1 528	1 792	6	0,15	4,5	6,7	4,5
1 500	1 644	1 794	22,3	12	9,5	1 534	1 916	8	0,20	3,4	5	3,2
	1 800	1 932	2 060	-	12	9,5	1 834	2 146	8	0,15	4,5	6,7

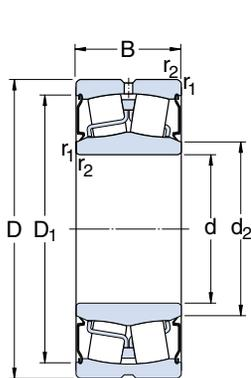

BS2-22-2CS(2)

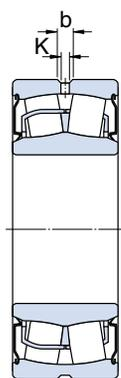

BS2-22 C-2CS(2)

Principal dimensions			Basic load ratings		Fatigue load limit P _u	Speed rating	Mass	Designations Bearings with cylindrical bore	tapered bore
d	D	B	C	C ₀					
mm			kN		kN	r/min	kg	–	
30	62	25	56	52	5,5	2 800	0,34	BS2-2206 C-2CS	–
35	72	28	76,5	73,5	8	2 400	0,52	BS2-2207 C-2CS	–
40	80	28	96,5	90	9,8	2 200	0,57	BS2-2208-2CS	BS2-2208-2CSK
45	85	28	90	88	9,5	2 000	0,63	BS2-2209 C-2CS	BS2-2209 C-2CSK
50	90	28	96,5	100	11	1 900	0,68	BS2-2210 C-2CS	BS2-2210 C-2CSK
55	100	31	125	127	13,7	1 700	1,00	BS2-2211-2CS	BS2-2211-2CSK
60	110	34	156	166	18,6	1 600	1,30	BS2-2212-2CS	BS2-2212-2CSK
65	100 120	35 38	115 170	173 183	20,4 21,2	1000 1 500	0,95 1,60	24013-2CS5/VT143 BS2-2213 C-2CS	– BS2-2213 C-2CSK
70	125	38	208	228	25,5	1 400	1,80	BS2-2214-2CS	BS2-2214-2CSK
75	115 130	40 38	152 212	232 240	28,5 26,5	950 1 300	1,55 2,10	24015-2CS2/VT143 BS2-2215-2CS	– BS2-2215-2CSK
80	140	40	236	270	29	1 200	2,40	BS2-2216-2CS	BS2-2216-2CSK
85	150	44	285	325	34,5	1 100	3,00	BS2-2217-2CS	BS2-2217-2CSK
90	160	48	325	375	39	1 000	3,70	BS2-2218-2CS	BS2-2218-2CSK
100	150 165 180 180	50 52 55 60,3	248 322 425 414	415 490 490 600	45,5 53 49 63	800 850 900 700	3,20 4,40 5,50 6,70	24020-2CS2/VT143 23120-2CS2/VT143 BS2-2220-2CS 23220-2CS	– – – –
110	170 180 180 200	45 56 69 63	267 430 460 560	440 585 750 640	46,5 61 78 63	900 800 630 800	3,75 5,55 6,85 7,60	23022-2CS 23122-2CS2/VT143 24122-2CS2/VT143 BS2-2222-2CS5/VT143	– – – –
120	180 180 200 215	46 60 80 69	355 430 575 630	500 670 950 765	52 68 95 73,5	850 670 560 750	4,20 5,40 10,0 9,75	23024-2CS2/VT143 24024-2CS2/VT143 24124-2CS2/VT143 BS2-2224-2CS	– – – –
130	200 200 210	52 69 80	430 540 587	610 815 1 000	61 81,5 100	800 600 530	6,10 7,95 11,0	23026-2CS2/VT143 24026-2CS2/VT143 24126-2CS2/VT143	– – –

The designations of Explorer bearings are printed in blue

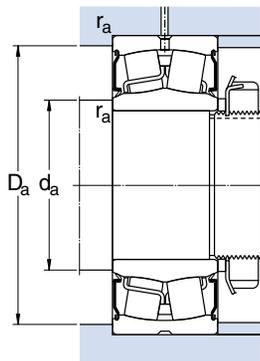

Dimensions						Abutment and fillet dimensions				Calculation factors			
d	d ₂ ≈	D ₁ ≈	b	K	r _{1,2} min	d _a min	d _a max	D _a max	r _a max	e	Y ₁	Y ₂	Y ₀
mm						mm				-			
30	36	55,7	3,7	2	1	36	36	56	1	0,33	2	3	2
35	43	63,7	3,7	2	1,1	42	43	65	1	0,31	2,2	3,3	3,2
40	47	73	5,5	3	1,1	47	47	73	1	0,28	2,4	3,6	2,5
45	53	77,1	5,5	3	1,1	52	53	78	1	0,26	2,6	3,9	2,5
50	58,1	82,1	5,5	3	1,1	57	58	83	1	0,24	2,8	4,2	2,8
55	64	91,9	5,5	3	1,5	64	64	91	1,5	0,24	2,8	4,2	2,8
60	69,3	100	5,5	3	1,5	69	69,3	101	1,5	0,24	2,8	4,2	2,8
65	71,9 74	92,8 111	5,5 5,5	3 3	1,1 1,5	71,6 74	71,6 74	93 111	1 1,5	0,27 0,24	2,5 2,8	3,7 4,2	2,5 2,8
70	80,1	115	5,5	3	1,5	79	79	116	1,5	0,23	2,9	4,4	2,8
75	81,8 84,5	105 119	5,5 5,5	3 3	1,1 1,5	81 84	81,8 84,5	109 121	1 1,5	0,28 0,22	2,4 3	3,6 4,6	2,5 2,8
80	92	128	5,5	3	2	91	92	129	2	0,22	3	4,6	2,8
85	98,2	138	5,5	3	2	96	98	139	2	0,22	3	4,6	2,8
90	103	148	5,5	3	2	101	103	149	2	0,24	2,8	4,2	2,8
100	108 113 114 114	139 152 160 160	5,5 5,5 8,3 8,3	3 3 4,5 4,5	1,5 2 2,1 2,1	107 111 112 112	108 113 114 114	143 154 168 169	1,5 2 2 2	0,28 0,27 0,24 0,30	2,4 2,5 2,8 2,3	3,6 3,7 4,2 3,4	2,5 2,5 2,8 2,2
110	122 123 121 126	157 166 163 182	8,3 8,3 5,5 8,3	4,5 4,5 3 4,5	2 2 2 2,1	120 121 121 122	122 123 121 126	160 169 169 188	2 2 2 2	0,22 0,27 0,35 0,25	3 2,5 1,9 2,7	4,6 3,7 2,9 4	2,8 2,5 1,8 2,5
120	133 130 132 136	168 166 179 193	5,5 5,5 5,5 11,1	3 3 3 6	2 2 2 2,1	130 130 131 132	133 130 132 136	170 170 189 203	2 2 2 2	0,20 0,28 0,37 0,26	3,4 2,4 1,8 2,6	5 3,6 2,7 3,9	3,2 2,5 1,8 2,5
130	145 141 142	186 183 190	8,3 5,5 5,5	4,5 3 3	2 2 2	140 140 141	145 141 142	190 190 199	2 2 2	0,21 0,30 0,33	3,2 2,3 2	4,8 3,4 3	3,2 2,2 2

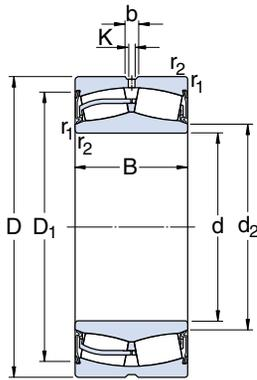

Principal dimensions			Basic load ratings		Fatigue load limit P_u	Speed rating	Mass	Designation Bearings with cylindrical bore
d	D	B	dynamic C	static C_0				
mm			kN		kN	r/min	kg	–
140	210	69	570	900	68	560	8,45	24028-2CS2/VT143
	225	85	673	1 160	112	450	12,7	24128-2CS2/VT143
150	225	75	655	1 040	100	530	10,5	24030-2CS2/VT143
	250	100	1020	1 530	146	400	19,5	24130-2CS2/VT143
160	240	80	750	1 200	114	450	13,0	24032-2CS2/VT143
	270	86	980	1 370	129	530	26,5	23132-2CS2/VT143
170	260	90	930	1 460	137	400	17,5	24034-2CS2/VT143
	280	109	1 280	1 860	170	360	26,5	24134-2CS2/VT143
180	280	100	937	1 730	156	380	23,0	24036-2CS2/VT143
190	320	128	1 600	2 500	212	340	42,0	24138-2CS2/VT143
200	340	140	1 800	2 800	232	320	52,0	24140-2CS
	360	128	1 860	2 700	228	430	58,0	23240-2CS2/VT143
220	300	60	630	1 080	93	600	13,0	23944-2CS

The designations of Explorer bearings are printed in blue

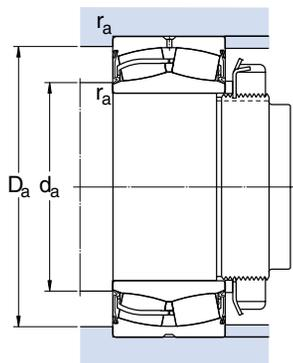

Dimensions						Abutment and fillet dimensions				Calculation factors			
d	d_2 ≈	D_1 ≈	b	K	$r_{1,2}$ min	d_a min	d_a max	D_a max	r_a max	e	Y_1	Y_2	Y_0
mm						mm				-			
140	152	194	5,5	3	2	150	152	200	2	0,28	2,4	3,6	2,5
	153	203	8,3	4,5	2,1	152	153	213	2	0,35	1,9	2,9	1,8
150	162	206	5,5	3	2,1	161	162	214	2	0,28	2,4	3,6	2,5
	163	221	8,3	4,5	2,1	162	163	238	2	0,37	1,8	2,7	1,8
160	173	218	8,3	4,5	2,1	171	173	229	2	0,28	2,4	3,6	2,5
	180	244	13,9	7,5	2,1	172	180	259	2	0,28	2,4	3,6	2,5
170	184	235	8,3	4,5	2,1	181	184	249	2	0,30	2,3	3,4	2,2
	185	249	8,3	4,5	2,1	182	185	268	2	0,37	1,8	2,7	1,8
180	195	251	8,3	4,5	2,1	191	195	269	2	0,31	2,2	3,3	2,2
190	210	284	11,1	6	3	204	210	306	2,5	0,40	1,7	2,5	1,6
200	220	300	11,1	6	3	214	220	326	2,5	0,40	1,7	2,5	1,6
	227	318	16,7	9	4	217	225	343	3	0,35	1,9	2,9	1,8
220	239	284	8,3	4,5	2,1	231	239	289	2	0,16	4,2	6,3	4

Related SKF products

Special spherical roller bearings

Their robust design and high reliability make SKF spherical roller bearings suitable for the majority of applications. However, extraordinary demands call for bearings with extraordinary features. Therefore, the SKF standard range includes special spherical roller bearings, which are adapted for specific applications:

Sealed bearings for continuous casting applications

These bearings are specially adapted for the high loads and operating temperatures and low speeds present in continuous casting slab guides. They feature seals made of fluoro rubber, and are filled with a very stable high temperature grease, allowing maintenance-free operation in this demanding environment.

Bearings for vibrating applications

Series 223 bearings with special clearance are modified to cope with shaft deflection encountered in vibrating applications. They are characterised by a hardened floating guide ring centred in the outer ring which guides the highly wear resistant, surface hardened window-type steel cages. To prevent fretting corrosion at the non-locating bearing position, a special version with PTFE-coated cylindrical bore is available.

Rolling mill bearings

Rolling mill bearings must meet a variety of different demands. For cold tube mills (Pilger mills), for example, the bearings must be able to withstand high acceleration forces, whereas for finishing trains or wire mills, they must be able to be mounted and dismantled with ease. SKF offers the appropriate spherical roller bearings for these applications.

SKF Pop Release units

These plummer block type mounted bearing units with series 222 Explorer bearing on a special adapter sleeve are greased, sealed and ready to install as delivered. With the saw-tooth profile of the inner ring and adapter sleeve, the unit can be mounted and dismantled easily via the incorporated screws without having to use special tools.

See also SKF brochures 4954 "The SKF Copperhead system solution for vibrating screens" and 5103 "Pop Release bearing units for speedier mounting".



Accessories

Any system is only as strong as its weakest member. Therefore, SKF offers not only a wide range of excellent spherical roller bearings, but also an appropriate range of quality bearing accessories to go with them.

Bearing housings

SKF offers a comprehensive range of high-quality standard and custom housings designed to accommodate the various demands placed on the bearings which they house, e.g. load, accuracy, type of lubrication and lubricant, sealing, etc.

Along with the appropriate SKF spherical roller bearings, these SKF housings comprise an economic and interchangeable unit which meets all the performance demands of a bearing application.

See also SKF catalogue 3766 "Bearing accessories" and SKF brochures 4403 "SNL plummer block housings solve the housing problems" and 5101 "SNL 30 and SNL 31 plummer block housings solve the housing problems".

Adapter and withdrawal sleeves

Adapter and withdrawal sleeves are used to locate bearings with tapered bore on smooth or stepped shafts. They facilitate bearing mounting and dismounting and, in many cases, simplify bearing arrangement design. Several series of quality sleeves are included in the SKF product range.

Lock nuts

SKF lock nuts, also referred to as shaft nuts, are available in several designs to axially locate bearings on shaft ends. The most popular are those of series KM, KML and HM. These nuts have four or eight equally spaced slots in the outside diameter and are locked in position with locking washers or locking clips engaging a groove in the shaft. The nut dimensions are in accordance with ISO 2982-2:1995 as are the dimensions of the series MB and MBL locking washers.

Other lock nuts produced by SKF include series KMT, KMTA, KMK and KMFE, that do not require a groove in the shaft.



SKF adapter and withdrawal sleeves



SKF lock nuts



Lubricants and lubrication equipment

Spherical roller bearings operate under the most varying load, speed, temperature and environmental conditions. They require the type of high-quality lubricating greases, which SKF provides.

SKF greases have been specially developed for rolling bearings in their typical applications. The SKF range includes fifteen environmentally friendly greases and covers practically all application requirements.

The range is complemented by a selection of lubrication accessories including

- automatic lubricators,
- grease guns,
- lubricant metering devices and
- a wide range of manually and pneumatically operated grease pumps.

Products for mounting and dismounting

Like all rolling bearings, SKF spherical roller bearings require a high degree of skill when mounting or dismounting, as well as the correct tools and methods.

The comprehensive SKF range of tools and equipment includes everything that is required:

- mechanical tools,
- heaters,
- hydraulic tools and equipment,
- pullers and withdrawal tools for all sizes of bearings.



Induction heater, hydraulic pumps, hydraulic nut, mounting fluid and anti-fretting paste from SKF

See also SKF catalogue MP3000 "SKF Maintenance and Lubrication Products".



*SKF lubricants:
always the best choice
for any kind of bearing
application*

Condition monitoring equipment

The goal of condition monitoring is to maximise the time that the machine is functioning well and minimise the number of breakdowns, thereby significantly reducing operating downtime and maintenance costs.

To achieve this, it is recommended that the bearing and machine condition be monitored either periodically or continuously. Condition monitoring enables incipient bearing damage to be detected and evaluated, so that bearing replacement can be scheduled for a time when the machine is not in operation, to avoid unplanned stoppages. Applied to all machinery (not just sensitive or problematic machines), condition monitoring improves machinery operation to an optimum level, often exceeding the original equipment specifications.

SKF provides a comprehensive range of condition monitoring equipment to measure all important parameters. These include

- temperature,
- speed,
- noise,
- oil condition,
- shaft alignment,
- vibration and
- bearing condition.

The range includes lightweight, hand-held devices for manual use as well as complex continuous monitoring systems for fixed installations in connection with preventive maintenance.

One example is the Machine Reliability Inspection System MARLIN™ which is at the leading edge of technology and allows storage of up to 2 000 measuring points. It can be used to diagnose machines and individual bearings and is backed by tailored software for the evaluation of the readings including enveloping vibration acceleration curves.

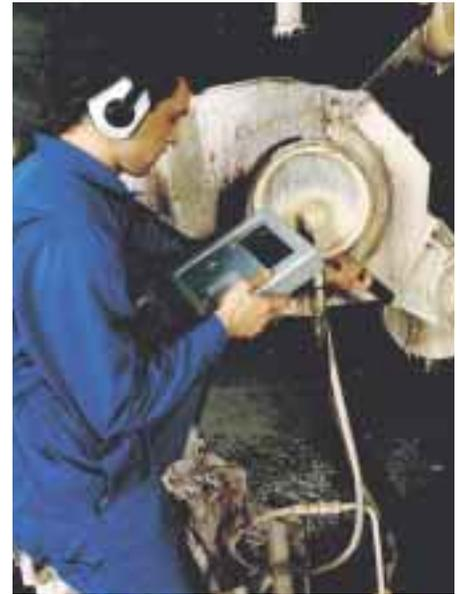

Recording vibration values using an SKF Microlog data collection unit

Taking the temperature



Noise testing



The MARLIN™ machine reliability inspection system



The SKF Group - a worldwide corporation

SKF is an international industrial Group operating in some 130 countries and is world leader in bearings.

The company was founded in 1907 following the invention of the self-aligning ball bearing by Sven Wingquist and, after only a few years, SKF began to expand all over the world.

Today, SKF has some 40 000 employees and around 80 manufacturing facilities spread throughout the world. An international sales network includes a large number of sales companies and some 7 000 distributors and retailers. Worldwide availability of SKF products is supported by a comprehensive technical advisory service.

The key to success has been a consistent emphasis on maintaining the highest quality of its products and services. Continuous investment in research and

development has also played a vital role, resulting in many examples of epoch-making innovations.

The business of the Group consists of bearings, seals, special steel and a comprehensive range of other high-tech industrial components. The experience gained in these various fields provides SKF with the essential knowledge and expertise required in order to provide the customers with the most advanced engineering products and efficient service.



SKF



The SKF Group is the first major bearing manufacturer to have been granted approval according to ISO 14001, the international standard for environmental management systems. The certificate is the most comprehensive of its kind and covers more than 60 SKF production units in 17 countries.



The SKF Engineering & Research Centre is situated just outside Utrecht in The Netherlands. In an area of 17 000 square metres (185 000 sq.ft) some 150 scientists, engineers and support staff are engaged in the further improvement of bearing performance. They are developing technologies aimed at achieving better materials, better designs, better lubricants and better seals – together leading to an even better understanding of the operation of a bearing in its application. This is also where the SKF Life Theory was evolved, enabling the design of bearings which are even more compact and offer even longer operational life.



SKF has developed the Channel concept in factories all over the world. This drastically reduces the lead time from raw material to end product as well as work in progress and finished goods in stock. The concept enables faster and smoother information flow, eliminates bottlenecks and bypasses unnecessary steps in production. The Channel team members have the knowledge and commitment needed to share the responsibility for fulfilling objectives in areas such as quality, delivery time, production flow etc.



SKF manufactures ball bearings, roller bearings and plain bearings. The smallest are just a few millimetres (a fraction of an inch) in diameter, the largest several metres. SKF also manufactures bearing and oil seals which prevent dirt from entering and lubricant from leaking out. SKF's subsidiaries CR and RFT S.p.A. are among the world's largest producers of seals.

® SKF and CARB are registered trademarks of SKF.

This publication supersedes the previous publications 4401 and 4404.

© Copyright SKF 2001

The contents of this publication are the copyright of the publisher and may not be reproduced (even extracts) unless permission is granted. Every care has been taken to ensure the accuracy of the information contained in this publication but no liability can be accepted for any loss or damage whether direct, indirect or consequential arising out of the use of the information contained herein.

Publication **5100 E** · December 2001

Printed in Sweden on environmentally friendly, chlorine-free paper (Multiart Silk) by Hyltebruks Tryckeri AB.