





# About > Bolting Systems™

## TOOLS

- Torque Wrenches
- Torque Wrench Accessories
- Bolt Tensioners
- Wind Tensioners
- Nut Splitters
- Flange Spreaders
- Flange Pullers
- Subsea Tensioners
- Subsea Accessories

## PUMPS

- Infinite Stage Electric & Air
- Compact 1,500 Bar Electric Tensioner
- Compact O&M Torque Wrench
- Classic Series Electric & Air Hydraulic
- Standard Flow Tensioner Power Packs
- High Flow & Subsea Tensioner Power Packs
- Hand

## ACCESSORIES

- Hoses
- Couplers
- Hydraulic Fluids
- Sockets
- Software
- Backup Wrenches

**SPX Bolting Systems** is a full service global manufacturer of controlled bolting solutions, including hydraulic torque and tensioning systems, industry specific certified training programs, system rentals and flange management database software. We are your partner in flange management, both in regards to infrastructure construction, operations and maintenance applications, enabling you to complete your project safely, in less time and on budget.

**SPX Bolting Systems** was formed when SPX Hydraulic Technologies, a division of SPX Corporation, acquired Torque Tension Systems LTD (TTS), of Ashington, UK. The new partnership combined the best high pressure (700 bar/10,000 psi) hydraulic power pack manufacturer, Power Team, with a premier torque and tensioning tool manufacturer, resulting in a “**best-in-class**” bolting system.

**SPX Bolting Systems** is dedicated to furthering controlled bolting solutions, engineering and manufacturing new technologies and utilizing advancements in material technology. This resulted in the continuous development of innovative products offering weight and size reduction, with increased safety, performance and durability.

**SPX Bolting Systems** has Rental, Sales & Service facilities located around the globe, with plans to add further service centers in other key locations to support our valuable customers. Repair & Calibration center locations include Houston, Texas, USA | Baton Rouge, LA, USA | Aberdeen, U.K. | Singapore and Perth, Australia. Additional customer service offices are located in the Netherlands and Shanghai. We also have a large distribution network that can offer local sales and service support in over 150 countries.

# ➤ Bolting Systems™

Best in Class  
Hydraulic Pumps,  
Torque Wrenches,  
Tensioners,  
Nut Splitters,  
Flange Spreaders,  
Other Tools and  
Software.



**Torque Wrenches**  
11-33



**Tensioners**  
35-45



**Other Tools**  
47-55



**Subsea Tools**  
57-65

See pages 48 for more information



**700 Bar (10,000 psi) Pumps**  
67-87



**1,500 Bar (21,750 psi) Pumps**  
89-



**Accessories**  
99-89

© 2014 SPX Corporation (doing business as SPX Hydraulic Technologies). All rights reserved. SPX reserves the right to alter or amend any published specification without notice. SPX tradenames, trademarks, or any part of the document or any of its contents may not be copied, reproduced, transmitted, modified or used, in whole or in part, without the express prior written consent of SPX Corporation. **SPX**, **X**, **➤**, Power Team, Flame-Out and Infinity **INFINITY** are trademarks of SPX Corporation.



**Resources**  
113-131

Every effort has been made to assure the accuracy of product descriptions in this catalog at the time of printing. SPX Corporation reserves the right to modify or discontinue products without prior notice.

# NUMERIC INDEX

9040 .....	104	HPUTP150002K .....	65, 95	TWL4-041 - TWL4-080 .....	30
9040, 9040E .....	53	HPUWP070010K .....	61, 64	TWL8-049 - TWL8-313 .....	28
9040E .....	104	HS2000, H3000 .....	51	TWL8-060 - TWL8-100 .....	30
9072 .....	100, 102	MRTAS010001 - MRTAS070008 .....	40	TWL15-062 - TWL15-463 .....	29
9616 .....	105	P19L .....	53	TWL15-070 - TWL55-155 .....	31
9636 - 9638 .....	105	P19, P19L .....	87	TWL30-080 - TWL30-463 .....	29
9639, 9640 .....	105	P59, P59L, P59F .....	87	TWL30-122 - TWL30-500 .....	29
9642 .....	53	PA60A .....	61	TWLC2-RB - TWLC30-RB .....	32
9645 - 9647 .....	105	PA60APF5FMP .....	73	TWLC2-RP - TWLC30-RP .....	32
9670 .....	53, 104	PA60APF5FMPR .....	73	TWLC2 - TWLC30 .....	27
9682 .....	53	PA60APF5FPP .....	73	TWR2-041036 - TWR8-100095 .....	30
9691 .....	53	PA60APF5FPPR .....	73	TWR15-070065 - TWR30-500463 .....	31
9764, 9764E .....	53, 104	PE8LXX3L, PE8PXX3L .....	91	TWSD1-ERA1 - TWSD25-ERA3 .....	22
9796 - 9800 .....	104	PE39PED1BPR .....	75	TWSD1-LRA - TWSD25-LRA .....	23
9797 .....	104	PE39PED1PR .....	75	TWSD1-RP - TWSD25-RP .....	23
9798 .....	53, 104	PE39YED1BPR .....	75	TWSD1 - TWSD25 .....	21
9799 .....	104	PE39YED1PR .....	75	TWSIA088 - TWSIA238 .....	25
9800 .....	104	PE45 .....	71	TWSIB088 - TWSIB425 .....	25
251410, 251411 .....	100, 102	PE55TWP-4-220-BS .....	77	TWSIC163 - TWSIC463 .....	25
251411 .....	100, 102	PE55TWP-4-BS .....	77	TWSIF313 - TWSIF613 .....	25
252364, 252365 .....	100	PE55TWP-4-CF-BS .....	77	TWSMA022 - TWSMA050 .....	25
308022 .....	50	PE55TWP-220-BS .....	77	TWSMB022 - TWSMB110 .....	25
308840 .....	50	PE55TWP-BS .....	77	TWSMC041 - TWSMC120 .....	25
350549 .....	54	PG120TWP .....	81	TWSMF080 - TWSMF150 .....	25
350550 .....	54	QRNAS010001 - QRNAS080005 .....	58	WDD1-M30 - WDD5-M42 .....	43
350822 .....	54	QRNAS020003 .....	63	WSD1-M30 - WSD5-M42 .....	44
350823 .....	54	RWP55-4-BS .....	83	WSL1-10, WSL1-11 .....	45
351985 .....	50	RWP55-4-BS-R .....	83	WSL1, WSL2 .....	45
2001772 .....	101, 103	RWP55-BS .....	83	WSL2-125, WSL2-138 .....	45
2002278 .....	101	RWP55-BS-R .....	83	WSS1-10, WSS1-11 .....	45
2008082, 2008083 .....	53	SB15 .....	53	WSS1, WSS2 .....	45
2008410 .....	53	SFP24220005 .....	62	WSS2-125, WSS2-138 .....	45
2008547 .....	101	SFPAD000002, SFPAD000002 .....	63	X1A1-PT .....	85
2008548 .....	103	SFPAS000001 .....	62	X1E1-PT, X1E2-PT .....	79
2008549 .....	102	SFPAS000003, SFPAS000008 .....	62		
2008550 .....	102	SFPQA000H00 - SFPQA000V00 .....	63		
3000610 .....	75	SFPSA000H00 - SFPSA000V00 .....	63		
DFTAS000001 - DFTAS000002 .....	17, 18, 22	SFPTA000H00 - SFPTA000V00 .....	63		
EHN1-TC - EHN23-TC .....	55	SFPWA000C00 - SFPWA000V00 .....	62		
ENSAS010001 - ENSAS040003 .....	49	SFPWR190005 .....	62		
ENSBLO10001 - ENSBLO40001 .....	48	SHRAS010002 .....	61		
FK59 .....	87	SRTAS000001 - SRTAS080001 .....	38		
FLS15, FLS15-ST .....	53	SRTAS000002 - SRTAS080014 .....	38		
HCUCV070001 .....	61, 64	SSTAS010001 - SSTAS080001 .....	58		
HFS3A, HFS6A .....	54	STDFA000167 .....	63		
HHAMA15002 .....	103	STDHC00025 .....	101		
HHAMA150001 - HHAMA150004 .....	101	TWD1-017 - TWD25-070 .....	24		
HHAMA150002 .....	65	TWD1-063 - TWD25-275 .....	24		
HHAMA150003 .....	101	TWH3E .....	100		
HHAMA150004 .....	101	TWH3E - TWH110E .....	100		
HL1M .....	103	TWH6E .....	100		
HL1M-LC .....	101	TWH06E-SS .....	102		
HL3M .....	103	TWH10E .....	100		
HL3M-LC .....	101	TWH15-BS - TWH50-BS .....	100		
HL5M .....	103	TWH20-BS .....	100		
HL5M-LC .....	101	TWH20-BS-SS .....	102		
HL8M .....	103	TWH50-BS .....	100		
HL8M-LC .....	101	TWHC1-ERA1 - TWHC1-ERA3 .....	18		
HL10M .....	103	TWHC1H - TWHC6H .....	17		
HL10M-LC .....	101	TWHC1-LRA - TWHC6-LRA .....	19		
HL13M .....	103	TWHC1-RP - TWHC6-RP .....	19		
HL13M-LC .....	101	TWHC1 - TWHC50 .....	17		
HL30M-DL .....	65, 103	TWHC3-ERA1 - TWHC3-ERA3 .....	18		
HNS150 .....	50	TWHC6-ERA1 - TWHC6-ERA3 .....	18		
HNS150A .....	50	TWHCHD01-017 - TWHCHD06-041 .....	24		
HNS225 .....	50	TWHCHD01-063 - TWHCHD06-163 .....	24		
HPSTP150004 .....	103	TWL2-026 - TWL2-188 .....	28		
HPUHP150001 .....	97	TWL2-032 - TWL2-060 .....	30		
HPUTP150001K .....	93	TWL4-033 - TWL4-313 .....	28		

## A

### ACCESSORIES

Hose Assembly - CE Hydraulic .....	104
Hydraulic Fluids .....	105
Hydraulic Hose Assembly - IJ100 .....	104
Splitters & Spreaders .....	104
Standard Twin-line Topside Hoses.....	100
Subsea Tension Hoses .....	103
Subsea Torque Wrench Couplers.....	102
Subsea Twin-line Hoses .....	102
Tensioner Hoses .....	101
Topside Tension .....	101
Topside Torque Wrench.....	100
Application Data Sheet.....	126

## C

### COUPLERS

Coupler Explanation.....	98
Spreaders & Splitters Couplers.....	104
Subsea Tension.....	103
Subsea Torque Wrench Couplers.....	102
Topside Torque Wrench .....	100

### CUSTOM PRODUCTS

Ring Tensioner.....	130
Spanner Link & Reaction Roller .....	130
Threaded Piston Tensioners.....	131
TWHC Accessories.....	131

## F

Flange Spreader - FLS15.....	52-53
Fluids, Hydraulic.....	105

## H

### HAND PUMPS

Hand Pumps Hydraulic - P Series.....	86-87
High Pressure Hand Pump .....	96-97

### HOSES

Standard Twin-line Topside Hoses.....	100
Subsea Hoses Twin-line .....	102
Subsea Tension Hoses .....	103
Tensioner Hoses .....	101
Hydraulic Bolting Safety.....	124-125

## I

Infinity Series Air Pump - PA60A .....	72-73
Infinity Series Electric Pump - PE45 .....	70-71

## M

### Measurements/Specifications

Manufacturing Standards .....	128
-------------------------------	-----

### MEASUREMENTS/SPECIFICATIONS -

Conversion Formulas	
Decimal & Millimeter Equivalents .....	114
SI* Conversion Formulas .....	115
Torque Requirements for Imperial Bolts.....	120
Torque Requirements for Metric Bolts.....	121
TWHC High Cycle Hydraulic Torque Wrench Pressure -	
Torque Conversion Chart .....	118
TWLC Low Clearance Hydraulic Torque Wrench Pressure -	
Torque Conversion Chart .....	117
TWSD Square Drive Hydraulic Torque Wrench Pressure -	
Torque Conversion Chart .....	116

### MEASUREMENTS/SPECIFICATIONS -

Reference Tables	
Recommended Bolt Stresses for ANSI B16.5, BS1560 and MSS SP44 Flanges.....	119
Typical Co-Efficient Values for Bolt Lubricants.....	119

## N

### NUT

EHN Top Collar.....	55
NUT SPLITTERS	
ENS Hydraulic Nut Splitter .....	48-49
HNS Hydraulic Nut Splitter.....	50

## O

Oil, Hydraulic.....	105
---------------------	-----

## P

Powerthon™ Lifetime Warranty.....	129
PUMPS -1,500 bar (21,750 psi)	
Electric Pump - PE8 .....	90-91
High Flow & Subsea Tensioner	
Air Power Pack - HPUTP-2 .....	94-95
High Pressure Hand Pump .....	96-97
Standard Flow Tensioner	
Air Power Pack - HPUTP-1 .....	92-93
PUMPS -700 bar (10,000 psi)	
Bolting Pump Summary Chart.....	68
Classic Series Air Hydraulic Pump - RWP55-BS .....	82-83
Classic Series Electric Hydraulic Pump - PE55TWP-BS .....	76-77
Classic Series Gas Hydraulic Pump - PG120TWP.....	80-81
Compact Electric Torque Wrench Pump - PE39.....	74-75
Hand Pumps Hydraulic - P Series.....	86-87
Infinity Series Air Pump - PA60A.....	72-73
Infinity Series Electric Pump - PE45.....	70-71
Legacy Series Air Hydraulic Pump - X1A1-PT.....	84-85
Legacy Series Electric Hydraulic Pump - X1E1-PT.....	78-79
The ISP Advantage .....	69
Pump Select Guide .....	6-7

## R

Rental, Calibration & Service Centers.....	110-111
--	---------

### RESOURCES

Application Data Sheet.....	126
Bolting Pump Summary Chart.....	68
Manufacturing Standards .....	128
Measurements/Specifications -	
Conversion Formulas.....	114-121
Powerthon™ Lifetime Warranty .....	129
Pump Select Guide.....	6-7
SPX Bolt Tensioners -	
How it Works.....	122-123
The ISP Advantage .....	69
Training.....	108-109

## S

### SOFTWARE

Advisor Bolt Load Calculator.....	107
FlangePro Flange	
Management Systems.....	106
Splitters & Spreaders.....	104

### SPREADERS

Flange Spreader - FLS15.....	52-53
Pipe Flange Spreader - HFS.....	54
Spreader - HS.....	51

### SUBSEA ACCESSORIES

High Flow Bolt-Tensioning Pump - HPUTP150002K.....	65
High Flow Pump - HPUWP070010K.....	64
Remote Diver Control Valve - HCUCV070001 .....	64
Single & Twin-line Hose Reels .....	64

### SUBSEA TENSIONERS

Flange Pullers - SFP.....	60-63
Stud Tensioner - SST .....	58-59
Subsea Accessories.....	64-65

## T

### TENSIONERS

Compact Tower Wind Tensioners - WSD .....	44
Foundation Wind Tensioners - WSS & WSL.....	45
Manual Return Bolt Tensioner - MRT .....	40-41
Spring Return Bolt Tensioner - SRT .....	37-39
SRT Advantages.....	36
Subsea Stud Tensioner - SST.....	58
Up Tower Wind Tensioners - WDD.....	43
Wind Tensioners - WD/WS.....	42

### TORQUE WRENCHES

Adapters & Sockets .....	24-25
Custom Accessories - TWLC .....	33
Drive Bodies - TWLC .....	26-27
High Cycle Torque Wrench - TWHC .....	16-17
Low Clearance Links - TWLC .....	28-29
Low Clearance Reducers - TWLC.....	30-31
Reaction Arms -TWHC.....	18-19
Reaction Arms - TWLC.....	32
Reaction Arms - TWSD.....	22-23
Reaction Paddles - TWLC .....	32
Square Drive Torque Wrench - TWSD .....	20-21
Torque Wrench Overview .....	14-15
Torque Wrench Selection Guide .....	12
Training .....	108-109

# PUMP SELECT GUIDE

## INSTRUCTIONS

This flow chart has been designed to guide you to the family of hydraulic pumps that is most likely to be the final selection for a given application.

1. Follow the flow chart to determine the product family that is most likely best suited for a given application.
2. Review the product information for the product family to ensure the specified pump meets all of the requirements of the application.
3. Select the item code of the pump to order.

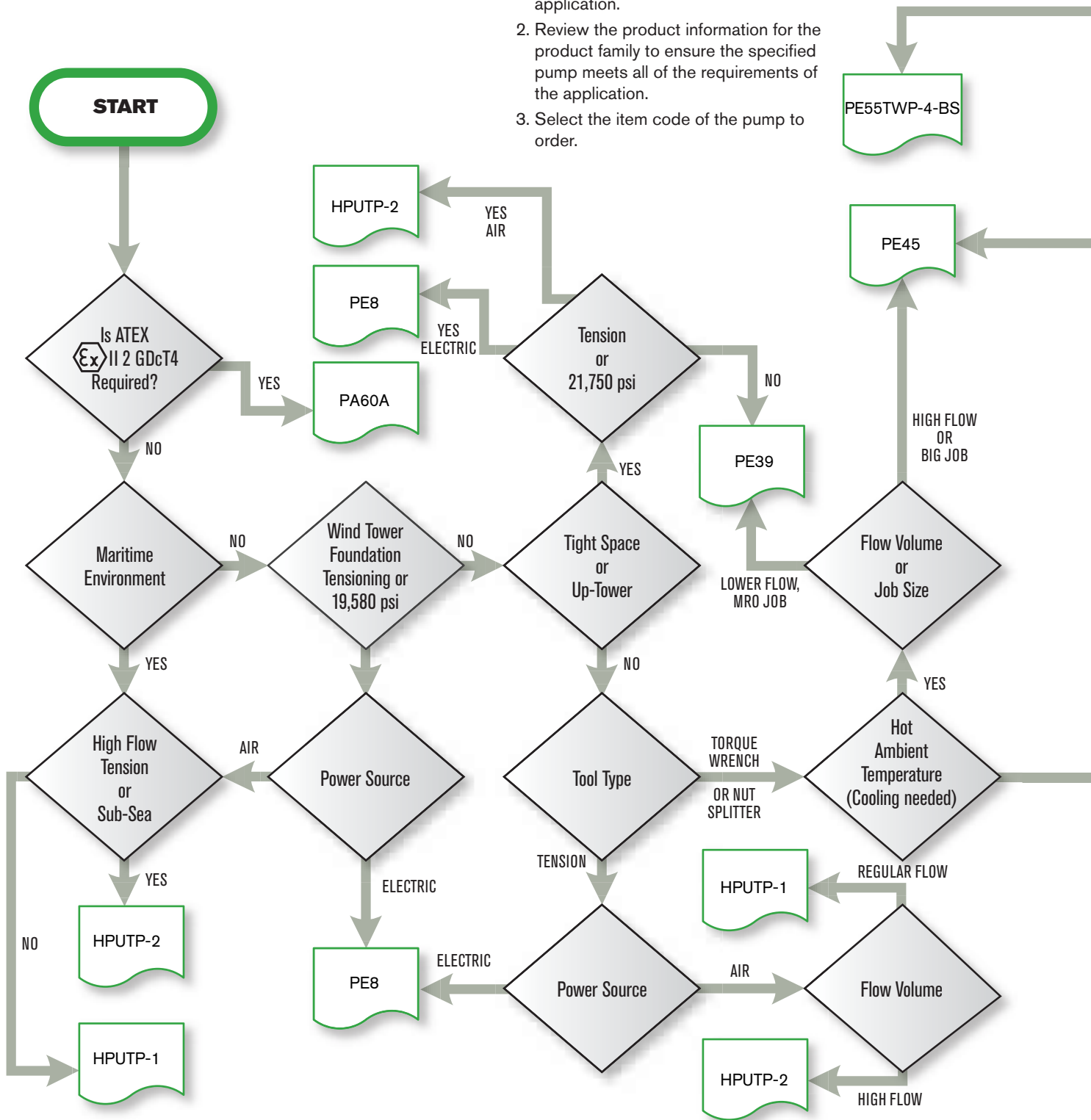

Due to the complexities involved in all of the hydraulic pump applications across the globe, this tool should be used as a guide only. After using this guide to find a pump family, a thorough review of the product should be completed to ensure suitability for a specific application and to find the proper item code. Additional product information can be found on sell sheets, in the catalog or on the web: [www.spxboltingsystems.com](http://www.spxboltingsystems.com) Please contact the factory or an authorized reseller with questions.

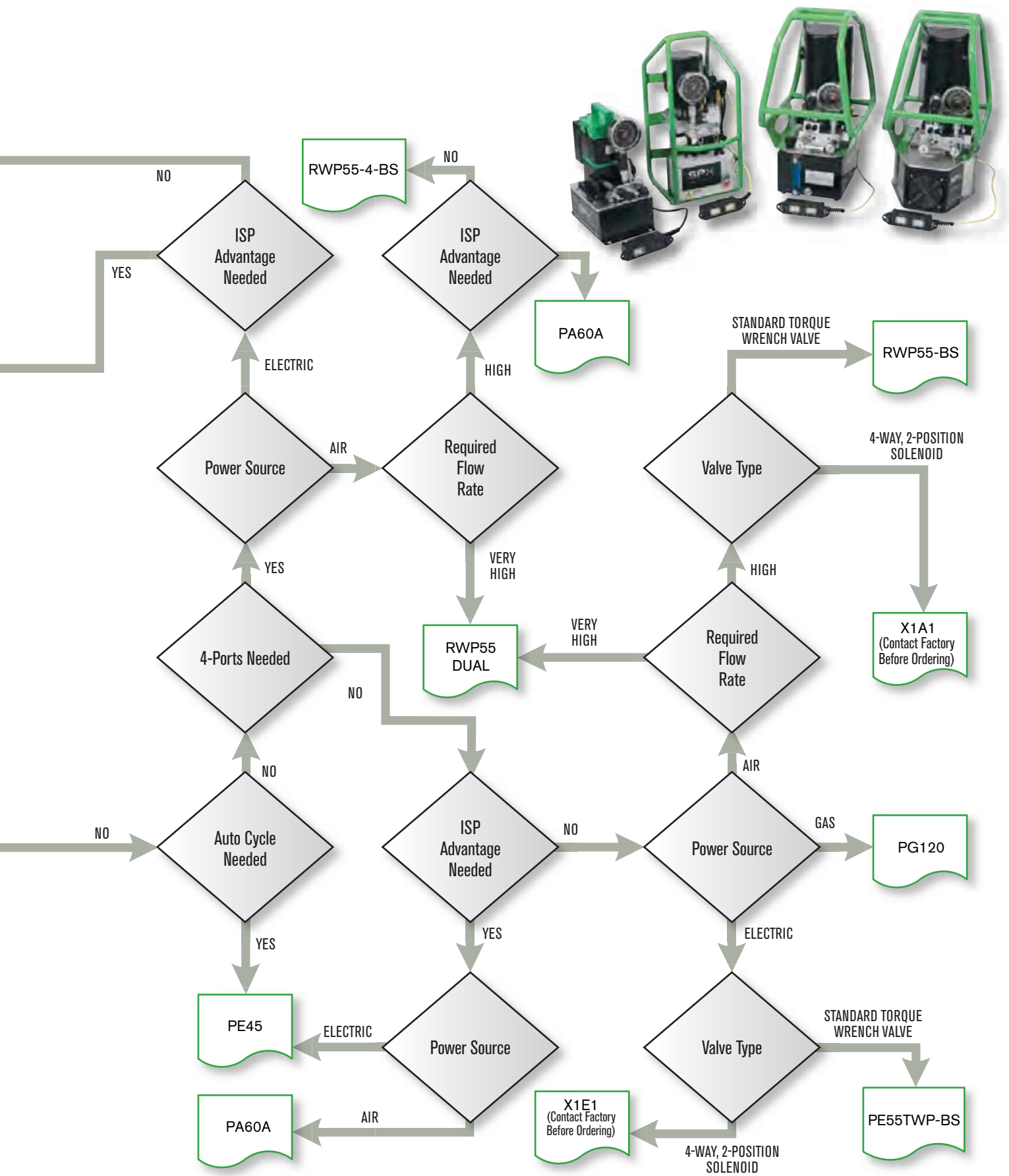







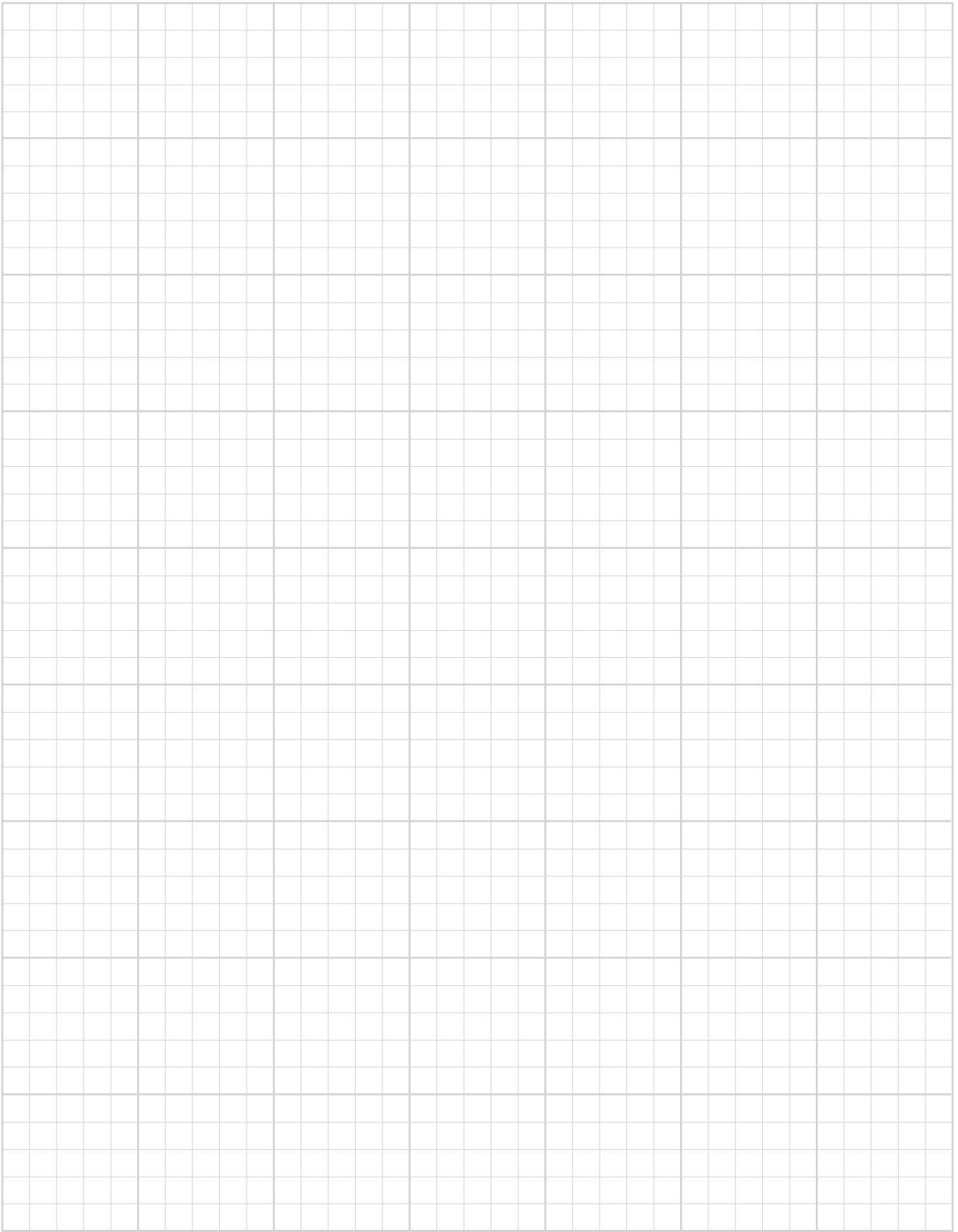

# TORQUE WRENCHES

**HIGH PERFORMANCE, BEST IN CLASS WRENCHES**



Page  
**MEASUREMENT/  
SPECIFICATIONS...12**  
Torque Wrench Selection Guide

Page  
**TORQUE WRENCH  
OVERVIEW...14-15**



Page  
**TWHC...16-17**  
High Cycle Torque Wrench



Page  
**TWSD...20-21**  
Square Drive Torque Wrench



Page  
**TWHC...18-19**  
Reaction Arms



Page  
**TWSD...22-23**  
Reactions Arms



Page  
**ADAPTERS &  
SOCKETS...24-25**



Page  
**TWLC...26-27**  
Drive Bodies



Page  
**TWLC...30-31**  
Low Clearance Reducers



Page  
**TWLC...28-29**  
Low Clearance Links



Page  
**TWLC...32**  
Reactions Arms



Page  
**TWLC...33**  
Custom Accessories



# MEASUREMENTS/ SPECIFICATIONS

## Torque Wrench Selection Guide



### Specifications and Dimensional Data

Bolt Stud Size		Standard Hex Nut Size		Heavy Hex Nut Size		Break Out Tool			Make Up Tool			
in	mm	in	mm	in	mm	TWHC	TWSD	TWLC	TWHC	TWSD	TWLC	
3/4	19	1-1/8	26	1-1/4	32	TWHC1	TWSD1	TWLC2	TWHC1	TWSD1	TWLC2	
7/8	22	1-5/16	33	1-7/16	36	TWHC1	TWSD1	TWLC2	TWHC1	TWSD1	TWLC2	
1	25	1-1/2	38	1-5/8	41	TWHC1	TWSD1	TWLC2	TWHC1	TWSD1	TWLC2	
1-1/8	26	1-11/16	43	1-13/16	25	TWHC1	TWSD1	TWLC2	TWHC1	TWSD1	TWLC2	
1-1/4	32	1-7/8	48	2	50	TWHC3	TWSD3	TWLC4	TWHC1	TWSD1	TWLC2	
1-3/8	35	2-1/16	52	2-3/16	55	TWHC6	TWSD6	TWLC4	TWHC3	TWSD3	TWLC4	
1-1/2	38	2-1/4	57	2-3/8	60	TWHC6	TWSD6	TWLC4	TWHC3	TWSD3	TWLC4	
1-5/8	41	2-7/16	62	2-9/16	65	TWHC6	TWSD6	TWLC8	TWHC6	TWSD6	TWLC4	
1-3/4	44	2-5/8	67	2-3/4	70	TWHC6	TWSD6	TWLC8	TWHC6	TWSD6	TWLC4	
1-7/8	48	2-13/16	71	2-15/16	75	-	TWSD11	TWLC8	TWHC6	TWSD6	TWLC8	
2	50	3	77	3-1/8	80		TWSD11	TWLC15	-	TWSD11	TWLC8	
2-1/8	54	3-3/16	81	3-5/16	84		TWSD11	TWLC15	-	TWSD11	TWLC8	
2-1/4	57	3-3/8	85	3-1/2	89		TWSD11	TWLC15	-	TWSD11	TWLC8	
2-3/8	60	3-9/16	91	3-11/16	94		TWSD25	TWLC15	-	TWSD11	TWLC15	
2-1/2	63	3-3/4	95	3-7/8	99		TWSD25	TWLC30	-	TWSD11	TWLC15	
2-3/4	70	4-1/8	105	4-1/4	108		TWSD25	TWLC30	-	TWSD25	TWLC15	
3	77	4-1/2	114	4 5/8	118		TWSD25	TWLC30	-	TWSD25	TWLC30	
3-1/4	83	4-7/8	124	5	127		TWSD25	TWLC30	-	TWSD25	TWLC30	
3-1/2	89	5-1/4	133	5 3/8	136		TWSD25	TWLC30	-	TWSD25	TWLC30	
3-3/4	95	5-5/8	-	5-3/4	146		TWSD25	TWLC30	-	TWSD25	TWLC30	
4	102	6	152	6 1/8	155		TWSD25	TWLC30	-	TWSD25	TWLC30	
4-1/4	108	-	-	6-1/2	159		TWHC50	-	TWLC30 Upon Request	TWHC50	-	TWLC30 Upon Request
4-1/2	114			6 7/8	175		TWHC50			TWHC50		
4-3/4	120			7-1/4	184	TWHC50	TWHC50					
5	127			7-5/8	193	TWHC50	TWHC50					

Additional torque may be required for loosening in certain situations:

- Rust and corrosion: 2 X break out force
- Heat Corrosion: 3 X break out force

Only the smallest tool suitable for each application, under ideal conditions, is shown.

Tools shown are a guideline only. Chart is not a replacement for calculations. Lubrication, corrosion, material type will all effect actual torque requirement.

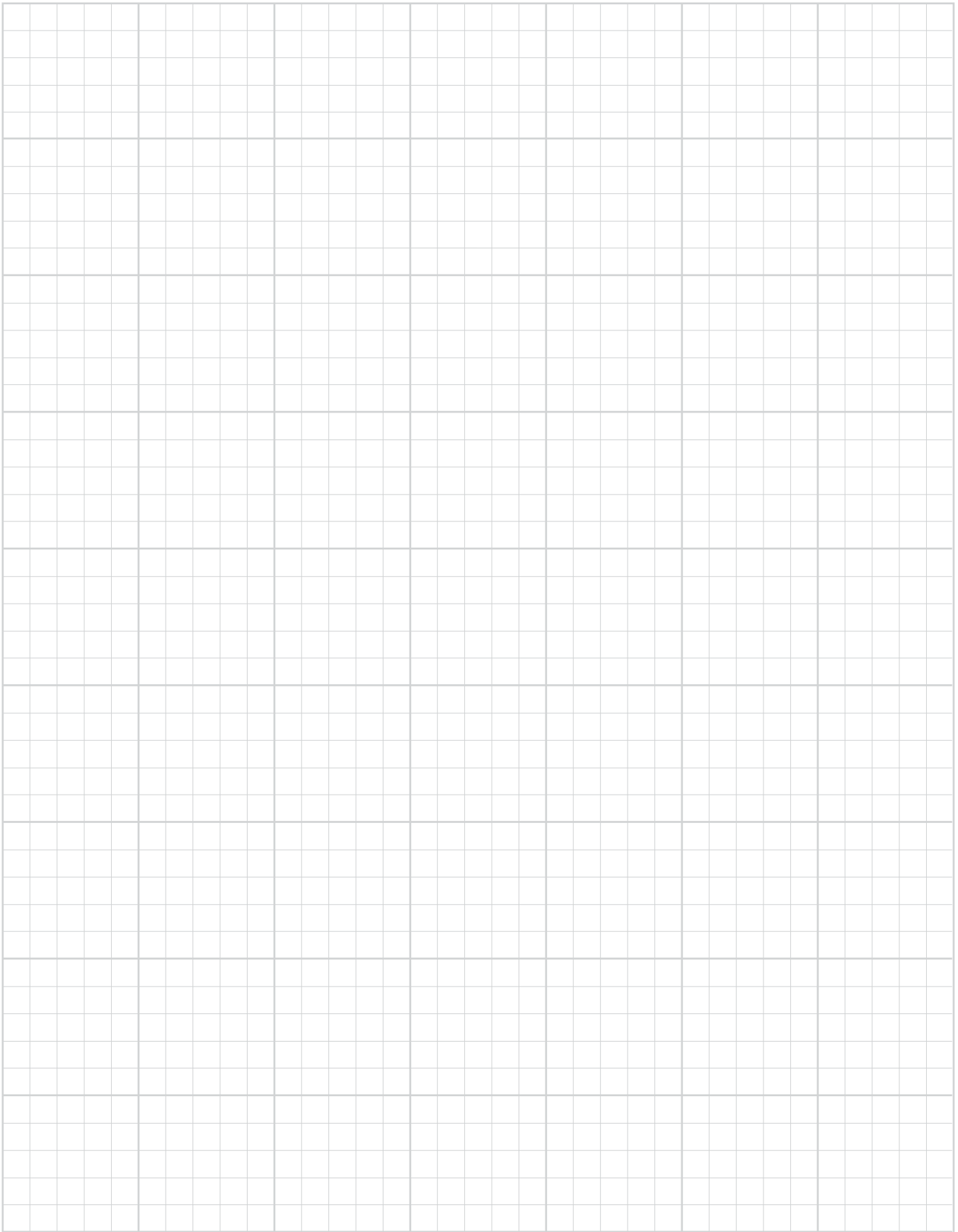

# TORQUE WRENCH OVERVIEW



## TWLC

Patented rotating slide design adapts to angle against the piston, keeping forces normal in order to reduce wear and tear.

Unique slide and shuttle piston design automatically engages without the need to manually rotate tool.

Multi way swivel allows easier positioning of the hoses on the job site.

Pin is retained to the link body and will not fall out or get lost on the job site.

Improved hardened steel reaction pad to protect the tool during torquing and modified radius to fit tighter applications.

Steel body link with corrosion resistant nickel plating. Aluminum power head to reduce the overall weight of the tool.

Fully enclosed components without use of a shroud which can bend and cause safety issues.





# TWHC

Multi-direction swivel allows operator to align the hoses in a convenient position, for any job!

Push button feature allows quick and easy release and re-positioning of the reaction arm without any tools.

Adaptable allen drive inserts for special applications, reference page 24.

With just a push of a button, the quick change square drive requires no tools to change from breakout to makeup.



## TORQUE WRENCH

### HIGH CYCLE - TWHC

Max Torque 71,816 Nm at 700 bar  
(53,000 lb-ft at 10,000 psi)



#### NEW TECHNOLOGY

## TORQUE WRENCH - HIGH CYCLE

### Quality means Lower Cost of Ownership:

- Designed for high cycle life: 2-3x more than existing technology
- Increased reliability: Simple drive assembly means less downtime
- Corrosion resistant material for use in harsh environments

### Enhanced Usability:

- Compact nose radius allows the tool to fit in tighter, hard-to-reach spaces
- Low weight, high strength design
- Fast operation, long stroke and optimum flow
- Multi-direction high flow swivel manifold
- Push button square drive reversal and reaction arm positioning
- Push-button release of square drive & reaction arm for all models except TWHC50.

### Designed with Safety in Mind:

- Fully enclosed drive mechanism for operator safety
- Swivel manifold internal relief valve prevents retract side over-pressurization
- Fine tooth pawl prevents tool 'lock-on'



#### HANDLES SOLD SEPARATELY

The tool's designed long-stroke mechanism imparts a minimum 30 degree nut rotation per stroke while maintaining a tight and compact nose radius: this is a clear advantage over the short stroke and back-up pawl mechanisms of light alloy competitive models. Fewer parts and reduced torsion in operation - equals reduced wear, maintenance and associated costs.

#### OK FOR SUBSEA





## Specifications and Dimensional Data

### TWHC

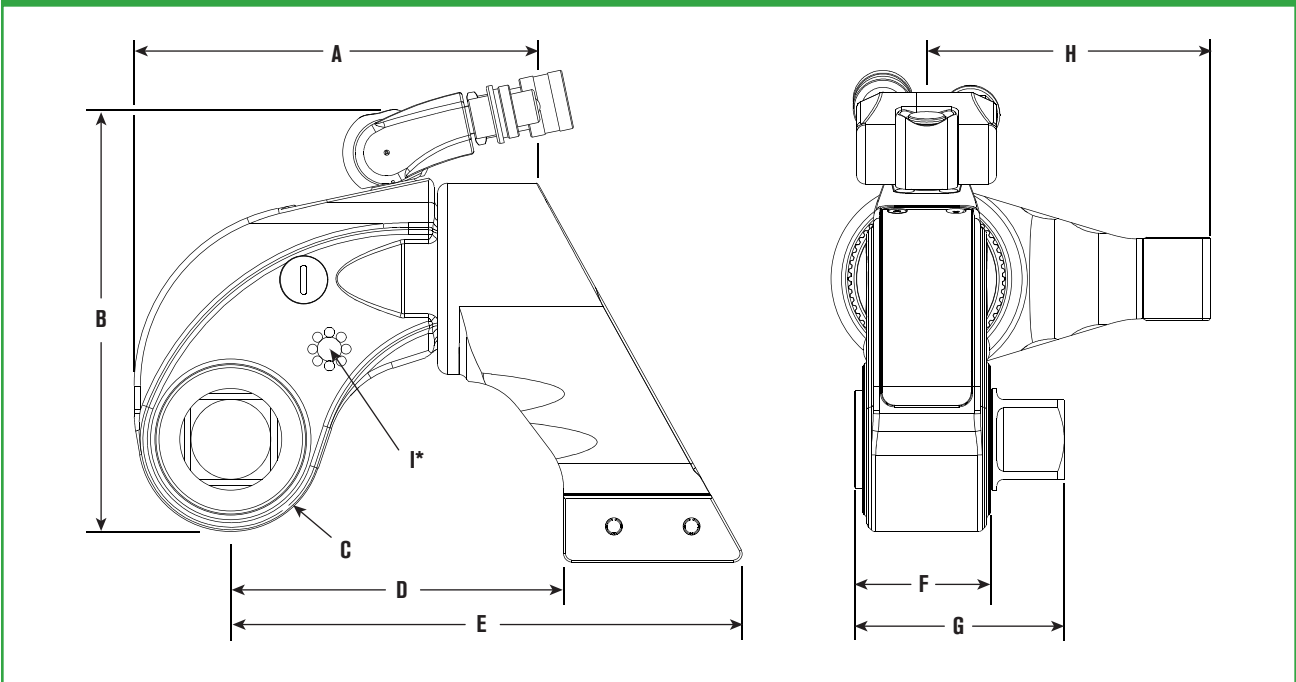

\* Dimension I shows thread size (on both sides of the tool) for safety handle or lifting point. TWHC50 model available with lifting points only.

Tool Model	Min Torque		Max Torque		Square Drive	A mm (in)	B mm (in)	C mm (in)	D mm (in)	E mm (in)	F mm (in)	G mm (in)	H mm (in)	I	Weight	
	lb-ft	Nm	lb-ft	Nm											in	Kg
<b>TWHC1</b>	170	230	1,413	1,915	3/4	132 (5.20)	145 (5.71)	28 (1.10)	111.5 (4.39)	170.0 (6.69)	39.5 (1.56)	67.7 (2.67)	86.1 (3.39)	M6 x 1.0	2.8	6.2
<b>TWHC3</b>	376	510	3,136	4,249	1	165 (6.50)	173.5 (6.83)	36.5 (1.44)	129.6 (5.10)	197.7 (7.78)	53 (2.09)	83.7 (3.30)	105.1 (4.14)	M6 x 1.0	5.3	11.7
<b>TWHC6</b>	726	984	6,050	8,198	1-1/2	192 (7.56)	201.6 (7.94)	44 (1.73)	158.5 (6.24)	243.7 (9.59)	61 (2.40)	99.9 (3.93)	135.1 (5.32)	M8 x 1.25	8.8	19.4
<b>TWHC50</b>	6,360	8,628	53,000	71,816	2-1/2	404.5 (15.93)	356.6 (14.04)	88 (3.46)	266.5 (10.49)	446.6 (17.58)	115 (4.53)	192.2 (7.57)	258 (10.16)	M12 x 1.75	69	152

### Ordering Information

Order No.	Description	Order No.	Description	Order No.	Description
<b>TWHC1</b>	Wrench	<b>TWHC1H</b>	Wrench with handle	<b>DFTAS000001</b>	Handle for TWHC1
<b>TWHC3</b>	Wrench	<b>TWHC3H</b>	Wrench with handle	<b>DFTAS000001</b>	Handle for TWHC3
<b>TWHC6</b>	Wrench	<b>TWHC6H</b>	Wrench with handle	<b>DFTAS000002</b>	Handle for TWHC6
<b>TWHC50</b>	Wrench				

# TORQUE WRENCH REACTIONS ARMS - TWHC

## TWHC EXTENDED REACTION ARM TWHC-ERA



- Long reach version of TWHC standard reaction arm
- 3 standard sizes per model (+25mm/50mm/75mm), specials upon request
- Replaces standard reaction arm – quick release pin locking
- Steel alloy construction
- 360° rotation
- Available for full range of tool sizes

## TW HANDLE



- Robust steel construction with ribbed polymer grip
- Multi-position on tool for balanced handling
- Cap-screw locking with positive 'docking'
- Is suitable for all wrench models (TWHC, TWSD, TWLC), however for larger sizes (TWSD25/TWLC 30/TWHC50) we recommend the use of eye-bolt lifting.

## Specifications and Dimensional Data

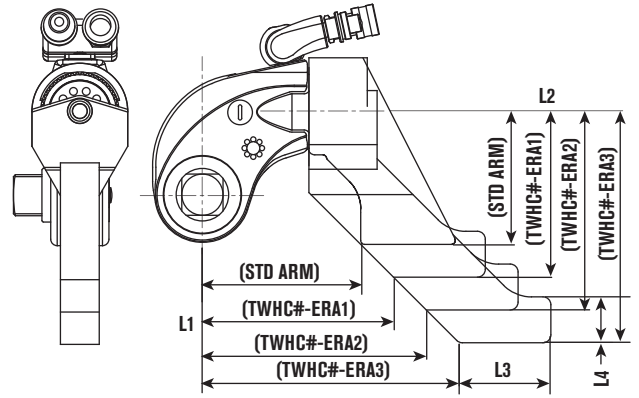

Tool Ref	Order No.	L1		L2		L3		L4	
		mm	in	mm	in	mm	in	mm	in
STD ARM		112	4.41	86	3.39				
TWHC1	TWHC1-ERA1	137	5.39	111	4.37	60	2.36	30	1.18
	TWHC1-ERA2	162	6.38	136	5.35				
	TWHC1-ERA3	187	7.36	161	6.34				
STD ARM		130	5.12	105	4.13				
TWHC3	TWHC3-ERA1	155	6.10	130	5.12	70	2.76	35	1.38
	TWHC3-ERA2	180	7.09	155	6.10				
	TWHC3-ERA3	205	8.07	180	7.09				
STD ARM		159	6.23	136	5.35				
TWHC6	TWHC6-ERA1	184	7.24	161	6.34	95	3.74	40	1.57
	TWHC6-ERA2	209	8.23	186	7.32				
	TWHC6-ERA3	234	9.21	211	8.31				

Order No.	Description	Tool Ref
DFTAS000001	Wrench Handle Size 1	TWSD1
		TWSD3
		TWHC1
		TWHC3
DFTAS000002	Wrench Handle Size 2	TWSD6
		TWSD11
		TWHC6
		TWLC4
		TWLC8
		TWLC15

### Specifications and Dimensional Data

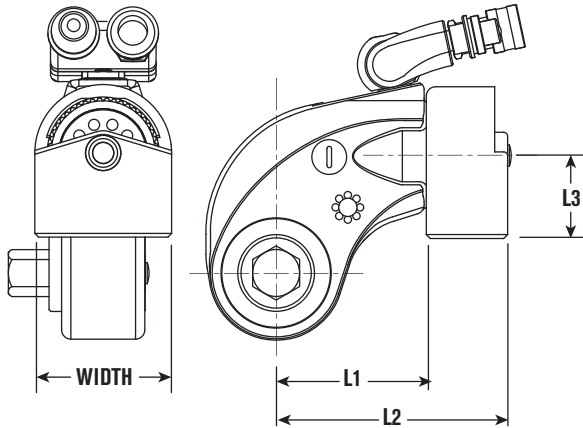

Tool Ref	Order No.	L1		L2		L3		Width	
		mm	in	mm	in	mm	in	mm	in
TWHC1	TWHC1-RP	72	2.835	116	4.567	49	1.93	64	2.52
TWHC3	TWHC3-RP	86	3.39	138	5.43	55	2.17	76	2.99
TWHC6	TWHC6-RP	99	3.90	162	6.38	62	2.44	89	3.50

### TWHC REACTION PAD TWHC-RP



- Wrench In-Line Reaction Pad for TWHC wrench: used as simple pad or modified platform for specific application (Machine-able/Weld-able platform)
- Replaces standard reaction arm – quick release pin locking
- Steel alloy construction
- 360 degree rotation
- Available for full range of tool sizes

### Specifications and Dimensional Data

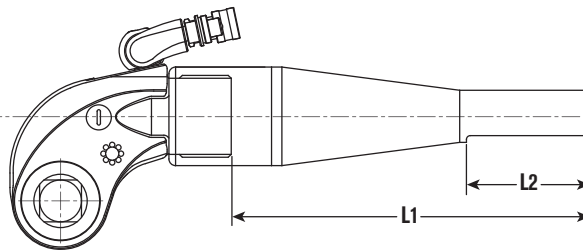

Tool Ref	Order No.	L1		L2	
		mm	in	mm	in
TWHC1	TWHC1-LRA	501	19.72	152	6
TWHC3	TWHC3-LRA				
TWHC6	TWHC6-LRA				

### TWHC LONG REACTION ARM TWHC-LRA



- Tubular extension arm for TWHC wrench: in-line reaction outside wrench profile
- Replaces standard reaction arm – quick release pin locking
- Steel/light alloy construction (reaction flat machined on tube end)
- Can be cut down to suit specific length
- Available for full range of tool sizes

## TORQUE WRENCH

### SQUARE DRIVE - TWSD

Max Torque 33,496 Nm at 700 bar  
(24,500 lb-ft at 10,000 psi)



360° Reaction Arm

**OK FOR SUBSEA**



## SQUARE DRIVE TORQUE WRENCH

- Low weight, high strength design
- Superior torsional strength
- Fast operation cycle
- Fine tooth ratchet
- Floating piston design
- Swivel manifold internal relief valve prevents retract side over-pressurization
- Rigid steel body construction
- Compact frame size
- Reaction and drive accessories available



## Specifications and Dimensional Data

- Push button reversal of square drive
- Corrosion resistant finish
- 360° reaction arm
- Push to lock reaction arms
- Multi-axis high flow swivel manifold
- Simple design
- Consistently accurate torque output
- Fully enclosed drive mechanism

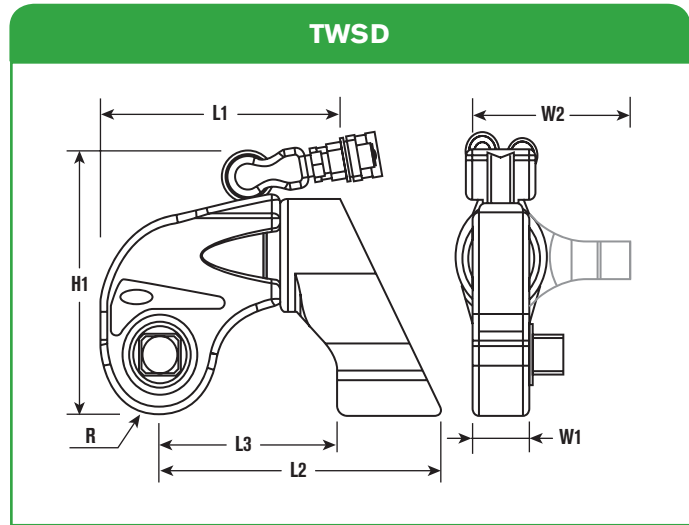

Tool Model	L1		L2		L3		H1		R		W1		W2	
	in	mm	in	mm	in	mm	in	mm	in	mm	in	mm	in	mm
TWSD1	5.5	139	6.7	170	4.4	112	5.7	145	1.1	28	1.3	33	3.4	86
TWSD3	6.7	170	7.7	196	4.9	124	6.9	175	1.5	38	1.8	46	4.1	104
TWSD6	7.7	196	9.3	236	5.6	142	8.1	206	1.8	46	2.0	51	5.4	137
TWSD11	9.2	234	11.5	292	7.0	178	9.5	241	2.2	56	2.4	61	6.5	165
TWSD25	12	305	14.8	376	9.1	231	12.4	315	2.8	71	3.0	76	7.9	200

Tool Model	Square Drive	Min Torque		Max. Torque		Tool Weight	
	in	lb-ft	Nm	lb-ft	Nm	lb	kg
TWSD1	3/4	156	211	1,300	1,762	5.1	2.3
TWSD3	1	368	499	3,070	4,160	9.9	4.5
TWSD6	1-1/2	722	979	6,020	8,157	17.4	7.9
TWSD11	1-1/2	1,313	1,780	10,940	14,823	28.9	13.1
TWSD25	2-1/2	2,940	3,984	24,500	33,198	65.0	29.5

## Ordering Information

Order No.	Description	Order No.	Description
<b>TWSD1</b>	WRENCH - 1,300 lb ft, 1,762 Nm	<b>DFTAS000001</b>	WRENCH HANDLE Size 1 Tool Ref. TWSD1 and TWSD3
<b>TWSD3</b>	WRENCH - 3,070 lb ft, 4,160 Nm	<b>DFTAS000002</b>	WRENCH HANDLE Size 2 Tool Ref. TWSD06 and TWSD11
<b>TWSD6</b>	WRENCH - 6,020 lb ft, 8,157 Nm		
<b>TWSD11</b>	WRENCH - 10,940 lb ft, 14,823 Nm		
<b>TWSD25</b>	WRENCH - 24,500 lb ft, 33,198 Nm		

Standard Reaction Arm included for all models

# TORQUE WRENCH REACTION ARMS - TWSD

## TWSD EXTENDED REACTION ARM TWSD-ERA



- Long reach version of TWSD standard reaction arm
- 3 standard sizes per model (+25mm/50mm/75mm), specials upon request
- Replaces standard reaction arm – quick release pin locking
- Steel alloy construction
- 360° rotation
- Available for full range of tool sizes

## TW HANDLE



- Robust steel construction with ribbed polymer grip
- Multi-position on tool for balanced handling
- Cap-screw locking with positive 'docking'
- Is suitable for all wrench models (TWHC, TWSD, TWLC), however for larger sizes (TWSD25/TWLC30/TWHC50) we recommend the use of eye-bolt lifting.

## Specifications and Dimensional Data

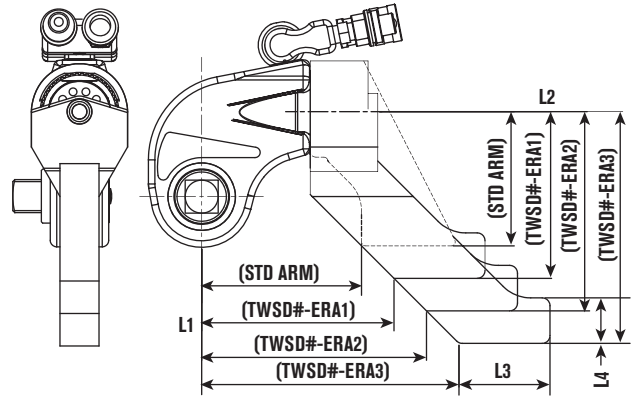

Tool Ref	Order No.	L1		L2		L3		L4	
		mm	in	mm	in	mm	in	mm	in
STD ARM		112	4.41	86	3.39				
TWSD1	TWSD1-ERA1	137	5.39	111	4.37	60	2.36	30	1.18
	TWSD1-ERA2	162	6.38	136	5.35				
	TWSD1-ERA3	187	7.36	161	6.34				
STD ARM		124	4.88	105	4.13				
TWSD3	TWSD3-ERA1	149	5.87	130	5.12	70	2.76	35	1.38
	TWSD3-ERA2	174	6.85	155	6.10				
	TWSD3-ERA3	199	7.83	180	7.09				
STD ARM		142	5.59	136	5.35				
TWSD6	TWSD6-ERA1	167	6.57	161	6.34	95	3.74	40	1.57
	TWSD6-ERA2	192	7.56	186	7.32				
	TWSD6-ERA3	217	8.54	211	8.31				
STD ARM		179	7.05	165	6.5				
TWSD11	TWSD11-ERA1	204	8.03	190	7.48	110	4.33	40	1.57
	TWSD11-ERA2	229	9.02	215	8.46				
	TWSD11-ERA3	254	10	240	9.45				
STD ARM		231	9.09	200	7.87				
TWSD25	TWSD25-ERA1	256	10.08	225	8.86	145	5.71	50	1.97
	TWSD25-ERA2	281	11.06	250	9.84				
	TWSD25-ERA3	306	12.05	275	10.83				
						147			

Order No.	Description	Tool Ref
DFTAS000001	Wrench Handle Size 1	TWSD1
		TWSD3
		TWHC1
		TWHC3
		TWLC2
DFTAS000002	Wrench Handle Size 2	TWSD6
		TWSD11
		TWHC6
		TWLC4
		TWLC8
		TWLC15

### Specifications and Dimensional Data

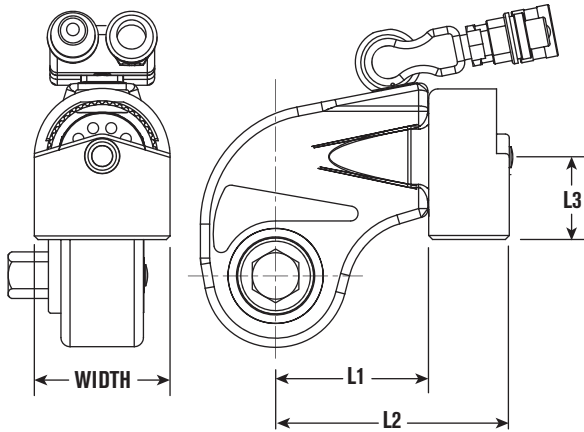

Tool Ref	Order No.	L1		L2		L3		Width	
		mm	in	mm	in	mm	in	mm	in
TWSD1	TWSD1-RP	72	2.835	116	4.567	43,5	1.713	63	2.480
TWSD3	TWSD3-RP	84	3.307	136	5.354	48	1.890	74	2.913
TWSD6	TWSD6-RP	93,5	3.681	155,5	6.122	57	2.244	90	3.543
TWSD11	TWSD11-RP	109,5	4.311	184,5	7.264	65,5	2.579	105	4.133
TWSD25	TWSD25-RP	136,5	5.374	243,5	9.587	88,5	3.484	143	5.630

### TWSD REACTION PAD TWSD-RP



- Wrench In-Line Reaction Pad for TWSD wrench: used as simple pad or modified platform for specific application (Machine-able/Weld-able platform)
- Replaces standard reaction arm – quick release pin locking
- Steel alloy construction
- 360 degree rotation
- Available for full range of tool sizes

### Specifications and Dimensional Data

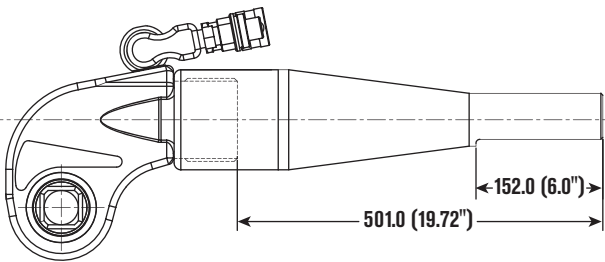

Tool Ref	Order No.	L1		L2	
		mm	in	mm	in
TWSD1	TWSD1-LRA	501	19.72	152	6
TWSD3	TWSD3-LRA				
TWSD6	TWSD6-LRA				
TWSD11	TWSD11-LRA				
TWSD25	TWSD25-LRA				

### TWSD LONG REACTION ARM TWSD-LRA



- Tubular extension arm for TWSD wrench: in-line reaction outside wrench profile
- Replaces standard reaction arm – quick release pin locking
- Steel/light alloy construction (reaction flat machined on tube end)
- Can be cut down to suit specific length
- Available for full range of tool sizes

# SQUARE DRIVE ADAPTERS & SOCKETS

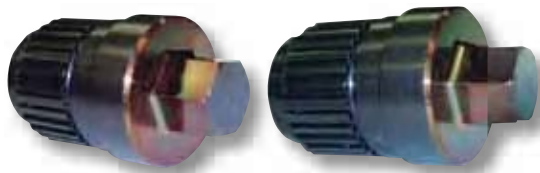

Customs sizes are available upon request

## Male Hex Drive

Wrench Size	Hexagon Drive Size A/F (inch)	Order No.		Hexagon Drive Size A/F (mm)	Order No.	
		TWSD	TWHC		TWSD	TWHC
1 (TWSD1) (TWHC1)	5/8	TWD1-063	TWHCHD01-063	17mm	TWD1-017	TWHCHD01-017
	3/4	TWD1-075	TWHCHD01-075	19mm	TWD1-019	TWHCHD01-019
	7/8	TWD1-088	TWHCHD01-088	22mm	TWD1-022	TWHCHD01-022
	1	TWD1-100	TWHCHD01-100	24mm	TWD1-024	TWHCHD01-024
				27mm	TWD1-027	TWHCHD01-027
3 (TWSD3) (TWHC3)	5/8	TWD3-063	TWHCHD03-063	17mm	TWD3-017	TWHCHD03-017
	3/4	TWD3-075	TWHCHD03-075	19mm	TWD3-019	TWHCHD03-019
	7/8	TWD3-088	TWHCHD03-088	22mm	TWD3-022	TWHCHD03-022
	1	TWD3-100	TWHCHD03-100	24mm	TWD3-024	TWHCHD03-024
	1-1/8	TWD3-113	TWHCHD03-113	27mm	TWD3-027	TWHCHD03-027
	1/14	TWD3-125	TWHCHD03-125	30mm	TWD3-030	TWHCHD03-030
	1-3/8	TWD3-138	TWHCHD03-138	32mm	TWD3-032	TWHCHD03-032
	1-1/2	TWD3-150	TWHCHD03-150	36mm	TWD3-036	TWHCHD03-036
6 (TWSD6) (TWHC6)	5/8	TWD6-063	TWHCHD06-063	17mm	TWD6-017	TWHCHD06-017
	3/4	TWD6-075	TWHCHD06-075	19mm	TWD6-019	TWHCHD06-019
	7/8	TWD6-088	TWHCHD06-088	22mm	TWD6-022	TWHCHD06-022
	1	TWD6-100	TWHCHD06-100	24mm	TWD6-024	TWHCHD06-024
	1-1/8	TWD6-113	TWHCHD06-113	27mm	TWD6-027	TWHCHD06-027
	1-1/4	TWD6-125	TWHCHD06-125	30mm	TWD6-030	TWHCHD06-030
	1-3/8	TWD6-138	TWHCHD06-138	32mm	TWD6-032	TWHCHD06-032
	1-1/2	TWD6-150	TWHCHD06-150	36mm	TWD6-036	TWHCHD06-036
11 (TWSD11)	1-5/8	TWD6-163	TWHCHD06-163	41mm	TWD6-041	TWHCHD06-041
	1-1/8	TWD11-113		27mm	TWD11-027	
	1-1/4	TWD11-125		30mm	TWD11-030	
	1-3/8	TWD11-138		32mm	TWD11-032	
	1-1/2	TWD11-150		36mm	TWD11-036	
25 (TWSD25)	1-5/8	TWD11-163		41mm	TWD11-041	
	1-3/4	TWD11-175		46mm	TWD11-046	
	1-1/2	TWD25-150		36mm	TWD25-036	
	1-5/8	TWD25-163		41mm	TWD25-041	
	1-3/4	TWD25-175		46mm	TWD25-046	
	1-7/8	TWD25-188		50mm	TWD25-050	
	2	TWD25-200		55mm	TWD25-055	
2-1/4	TWD25-225		60mm	TWD25-060		
2-1/2	TWD25-250		65mm	TWD25-065		
2-3/4	TWD25-275		70mm	TWD25-070		





### Impact Sockets - Imperial (for TWHC & TWSD)

Socket Size Imperial	3/4" Drive Order No.	1" Drive Order No.	1-1/2" Drive Order No.	2-1/2" Drive Order No.
7/8"	TWSIA088	TWSIB088	-	-
1-1/16"	TWSIA106	TWSIB106	-	-
1-1/4"	TWSIA125	TWSIB125	-	-
1-3/8"	TWSIA138	TWSIB138	-	-
1-7/16"	TWSIA144	TWSIB144	-	-
1-5/8"	TWSIA163	TWSIB163	TWSIC163	-
1-13/16"	TWSIA181	TWSIB181	-	-
2"	TWSIA200	TWSIB200	TWSIC200	-
2-3/16"	TWSIA219	TWSIB219	TWSIC219	-
2-3/8"	TWSIA238	TWSIB238	TWSIC238	-
2-9/16"	-	TWSIB256	TWSIC256	-
2-3/4"	-	TWSIB275	TWSIC275	-
2-15/16"	-	TWSIB294	TWSIC294	-
3-1/8"	-	TWSIB313	TWSIC313	TWSIF313
3-3/8"	-	TWSIB338	TWSIC338	TWSIF338
3-1/2"	-	TWSIB350	TWSIC350	TWSIF350
3-3/4"	-	TWSIB375	TWSIC375	TWSIF375
3-7/8"	-	TWSIB388	-	TWSIF388
4-1/8"	-	TWSIB413	TWSIC413	TWSIF413
4-1/4"	-	TWSIB425	TWSIC425	TWSIF425
4-5/8"	-	-	TWSIC463	TWSIF463
5"	-	-	-	TWSIF500
5-3/8"	-	-	-	TWSIF538
5-3/4"	-	-	-	TWSIF575
6-1/8"	-	-	-	TWSIF613

### Impact Sockets - Metric (for TWHC & TWSD)

Socket Size Metric	3/4" Drive Order No.	1" Drive Order No.	1-1/2" Drive Order No.	2-1/2" Drive Order No.
22mm	TWSMA022	TWSMB022	-	-
24mm	TWSMA024	TWSMB024	-	-
32mm	TWSMA032	TWSMB032	-	-
36mm	TWSMA036	TWSMB036	-	-
41mm	TWSMA041	TWSMB041	TWSMC041	-
46mm	TWSMA046	TWSMB046	-	-
50mm	TWSMA050	TWSMB050	-	-
55mm	-	TWSMB055	-	-
60mm	-	TWSMB060	TWSMC060	-
65mm	-	TWSMB065	TWSMC065	-
70mm	-	TWSMB070	TWSMC070	-
75mm	-	-	TWSMC075	-
80mm	-	TWSMB080	TWSMC080	TWSMF080
85mm	-	TWSMB085	TWSMC085	TWSMF085
90mm	-	TWSMB090	TWSMC090	TWSMF090
95mm	-	TWSMB095	TWSMC095	TWSMF095
100mm	-	TWSMB100	-	TWSMF100
110mm	-	TWSMB110	TWSMC110	TWSMF110
115mm	-	-	TWSMC115	TWSMF115
120mm	-	-	TWSMC120	-
135mm	-	-	-	TWSMF135
150mm	-	-	-	TWSMF150

For Long Reach (Extended Length) sockets add "LR" to the end of the part number. For 12 point (bi-hex) sockets, add "BH" to the end of the part number.

## TORQUE WRENCH LOW CLEARANCE - TWLC

Max Torque 39,047 Nm at 700 bar  
(28,800 lb-ft at 10,000 psi)



Shown with  
optional handle

## TORQUE WRENCH LOW CLEARANCE

The TWLC Series Wrench was designed for the most inaccessible bolting areas found in the industry. Its long neck, short height and small radius have all added to its great success.



Several link sizes are  
available for each drive.

Combine a drive body with a link to make a wrench.  
Each are sold separately.

**OK FOR SUBSEA**



## Specifications and Dimensional Data

- Low weight, high strength design
- Superior torsional strength
- Fast operation cycle
- Fine tooth ratchet
- Floating piston design
- Link pin does not fall out
- Auto-connect drive piston
- Compact frame size
- Rigid steel body construction
- Swivel manifold internal relief valve prevents retract side over-pressurization
- "Hardened" steel reaction pad on TWLC8, 15 & 30
- Small nose radius
- Corrosion resistant finish
- Multi-axis high flow swivel manifold
- Simple design
- Consistent torque output

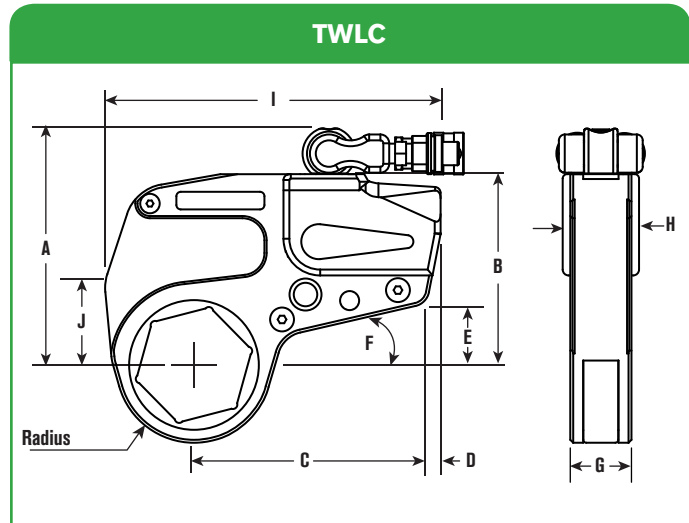

- Quick interchangeable heads, no tools necessary
- Replaceable reaction pad on larger models

Body Order No.	A		B		C		D		E		F		G		H	
	in	mm	in	mm	in	mm	in	mm	in	mm	in	mm	in	mm	in	mm
TWLC2	3.8	97	4.1	103	5	128	0.3	8	1.4	35	0.5	13	1.3	32	1.7	42
TWLC4	4.7	120	5.1	130	6.3	159	0.4	9	1.7	43	0.5	13	1.7	42	2	52
TWLC8	5.8	147	6.2	158	7	177	1	24.5	1.6	40	0.6	14	2.1	54	2.6	67
TWLC15	6.9	174	7.3	186	7.9	200	1.1	27	1.7	43	0.6	14	2.5	63	3	76
TWLC30	8.8	223	9.4	239	10.5	267	1	26	2.4	62	0.6	15	3.2	82	3.7	94

Body Order No.	Hex Range				Min Torque		Max. Torque		Weight (Body Only)	
	in	in	mm	mm	lb. ft.	Nm	lb-ft	Nm	lb	kg
TWLC2	1-1/8	2-3/8	26	60	189	256	1,575	2,134	2.2	1.0
TWLC4	1-5/16	3-1/8	33	80	477	646	3,975	5,386	4.4	2.0
TWLC8	1-7/8	3-15/16	49	100	954	1,293	7,950	10,772	7.7	3.5
TWLC15	2-7/16	4-5/8	62	116	1,782	2,415	14,850	20,122	15.4	7.0
TWLC30	3-1/8	6-1/16	80	155	3,456	4,683	28,800	39,024	31.9	14.5

CAUTION: Always read operating manual before using for proper use of tools and accessories.

NOTE: Reference dimensions shown and vary by links size. Exact dimensions can be found on our website.

## Ordering Information

### TO SPECIFY A TWLC SOLUTION:

1. Find a link for your application (nut size) (page 28-29)
2. Choose the appropriate Drive body (page 27)
3. Add reducers for additional nut sizes (pages 30-31)

Please order Drive Body and Link separately and pay attention to the same size, for Example TWLC2 and TWL2-041.

# TORQUE WRENCH

## LOW CLEARANCE LINKS - TWLC

Parts Codes, Nose Radius



Nut A/F		Link Order No.	TWLC2				Link Order No.	TWLC4				Link Order No.	TWLC8							
Inch	Metric		Radius R mm (in)	I mm (in)	J mm (in)	Weight (Link Only) kg (lb)		Radius R mm (in)	I mm (in)	J mm (in)	Weight (Link Only) kg (lb)		Radius R mm (in)	I mm (in)	J mm (in)	Weight (Link Only) kg (lb)				
1-1/8	26	TWL2-026																		
1-3/16	30	TWL2-030																		
1-1/4	32	TWL2-032	31.5 (1.2)	180 (7.1)	38 (1.5)	2 (4.4)														
1-5/16	33	TWL2-033																		
1-3/8	35	TWL2-035																		
1-7/16	36	TWL2-036																		
1-1/2	38	TWL2-150																		
1-9/16	40	TWL2-040	34.5 (1.4)	181 (7.1)	40 (1.6)	2 (4.4)														
1-5/8	41	TWL2-041																		
1-11/16	43	TWL2-043																		
1-3/4	44	TWL2-044	37 (1.5)	183 (7.2)	40 (1.6)	2 (4.4)														
1-13/16	46	TWL2-046																		
1-7/8		TWL2-188																		
1-15/16	49	TWL2-049	40 (1.6)	185 (7.3)	43 (1.7)	2 (4.4)														
2	50	TWL2-050																		
2-1/16	52	TWL2-052																		
2-1/8	54	TWL2-054	42.5 (1.7)	185 (7.3)	43 (1.7)	2 (4.4)														
2-3/16	55	TWL2-055																		
2-1/4	57	TWL2-057																		
2-5/16	59	TWL2-059	45.5 (1.8)	185 (7.3)	43 (1.7)	2 (4.4)														
2-3/8	60	TWL2-060																		
2-7/16	62																			
2-1/2	63																			
2-9/16	65																			
2-5/8	67																			
2-11/16	68																			
2-3/4	70																			
2-13/16	71																			
2-7/8	73																			
2-15/16	75																			
3	77																			
3-1/16	78																			
3-1/8	80																			
3-3/16	81																			
3-1/4	83																			
3-5/16	84																			
3-3/8	85																			
3-7/16	87																			
3-1/2	89																			
	90																			
3-9/16	91																			
3-5/8	92																			
3-11/16	94																			
3-3/4	95																			
3-13/16	97																			
3-7/8	99																			
3-15/16	100																			

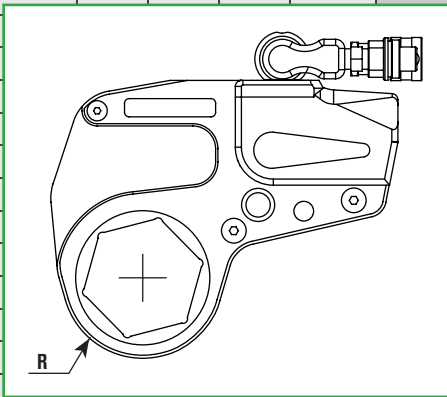

MORE SOLUTIONS ON NEXT PAGE



Nut A/F		Link Order No.	TWLC15				Link Order No.	TWLC30				Link Order No.	Nut A/F		Link Order No.	TWLC30 (Continued)			
Inch	Metric		Radius R	I	J	Weight (Link Only)		Radius R	I	J	Weight (Link Only)		Inch	Metric		Radius R	I	J	Weight (Link Only)
			mm (in)	mm (in)	mm (in)	kg (lb)	mm (in)	mm (in)	mm (in)	kg (lb)			mm (in)	mm (in)	mm (in)	kg (lb)			
2-7/16	62	TWL15-062										4-13/16	122	TWL30-122					
2-1/2	63	TWL15-063											123	TWL30-123					
2-9/16	65	TWL15-065	60.5 (2.4)	313 (12.3)	88 (3.5)	12.5 (27.5)						4-7/8	124	TWL30-124	99 (3.9)	400 (15.7)	109 (4.3)	28.5 (62.7)	
2-5/8	67	TWL15-067										4-15/16	125	TWL30-125					
2-11/16	68	TWL15-068										5	127	TWL30-500					
2-3/4	70	TWL15-070										5-1/16	129	TWL30-129					
2-13/16	71	TWL15-071										5-1/8	130	TWL30-130					
2-7/8	73	TWL15-073	63 (2.5)	313 (12.3)	88 (3.5)	12.5 (27.5)						5-3/16	132	TWL30-132	105 (4.1)	400 (15.7)	109 (4.3)	28.5 (62.7)	
2-15/16	75	TWL15-075										5-1/4	133	TWL30-133					
3	77	TWL15-077										5-5/16	135	TWL30-135					
3-1/16	78	TWL15-313	66.5 (2.6)	313 (12.3)	88 (3.5)	13 (28.6)						5-3/8		TWL30-538					
3-1/8	80	TWL15-080										5-7/16	138	TWL30-138					
3-3/16	81	TWL15-081										5-1/2	140	TWL30-140					
3-1/4	83	TWL15-083										5-9/16	141	TWL30-141					
3-5/16	84	TWL15-084										5-5/8	143	TWL30-143	110 (4.3)	400 (15.7)	109 (4.3)	28.5 (62.7)	
3-3/8	85	TWL15-085	72 (2.8)	313 (12.3)	8 (0.3)	13.5 (29.7)						5-11/16	144	TWL30-144					
3-7/16	87	TWL15-087											145	TWL30-145					
3-1/2	89	TWL15-089											5-3/4	146	TWL30-146				
	90	TWL15-090											5-13/16	148	TWL30-148				
3-9/16	91	TWL15-091											5-7/8	149	TWL30-149				
3-5/8	92	TWL15-092												150	TWL30-150				
3-11/16	94	TWL15-094											5-15/16	151	TWL30-151	116 (4.6)	400 (15.7)	109 (4.3)	29.5 (64.9)
3-3/4	95	TWL15-095	78 (3.1)	316 (12.4)	80 (3.1)	13.5 (29.7)							6	152	TWL30-152				
3-13/16	97	TWL15-097											6-1/16	154	TWL30-154				
3-7/8	99	TWL15-388											6-1/8	155	TWL30-155				
3-15/16	100	TWL15-100																	
4	102	TWL15-102																	
4-1/16	103	TWL15-103																	
4-1/8	105	TWL15-105	82.5 (3.2)	316 (12.4)	80 (3.1)	14 (30.8)													
4-3/16	106	TWL15-106																	
4-1/4	108	TWL15-425																	
4-5/16	110	TWL15-110																	
4-3/8	111	TWL15-111																	
4-7/16	113	TWL15-113																	
4-1/2	114	TWL15-114	87.5 (3.4)	316 (12.4)	80 (3.1)	14 (30.8)													
	115	TWL15-115																	
4-9/16	116	TWL15-116																	
4-5/8		TWL15-463																	
4-11/16	119																		
4-3/4	120																		

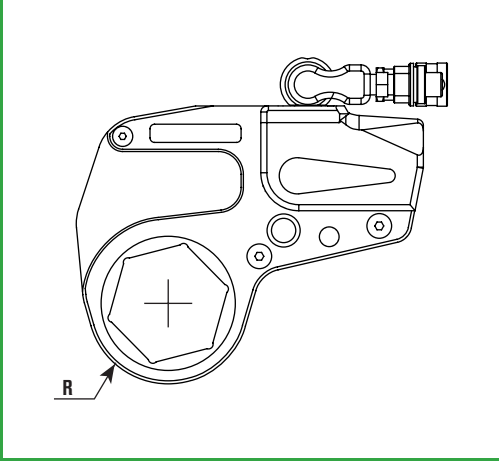

MORE SOLUTIONS ON NEXT PAGE

# TORQUE WRENCH

## LOW CLEARANCE REDUCERS - TWLC

Drive Body, Links & Reducers

Special sizes available upon request.



### Specifications and Dimensional Data

Body Order No.	Link Order No.	Nut A/F		Reducer			Reducer			Reducer		
		in	mm	in	mm	Order No.	in	mm	Order No.	in	mm	Order No.
TWLC2	TWL2-032	1-1/4	32	-	-	-	-	-	-	-	-	-
	TWL2-036	1-7/16	36	-	-	-	-	-	-	-	-	-
	TWL2-041	1-5/8	41	1-5/8 - 1-7/16	41-36mm	TWR2-041036	1-5/8 - 1-1/4	41-32mm	TWR2-041032	-	-	-
	TWL2-046	1-13/16	46	1-13/16 - 1-5/8	46-41mm	TWR2-046041	1-13/16 - 1-7/16	46-36mm	TWR2-046036	1-13/16 - 1-1/4	46-32mm	TWR2-046032
	TWL2-050	2	50	2 - 1-13/16	50-46mm	TWR2-050046	2 - 1-5/8	50-41mm	TWR2-050041	2 - 1-7/16	50-36mm	TWR2-050036
	TWL2-055	2-3/16	55	2-3/16 - 2	55-50mm	TWR2-055050	2-3/16 - 1-13/16	55-46mm	TWR2-055046	2-3/16 - 1-5/8	55-41mm	TWR2-055041
	TWL2-060	2-3/8	60	2-3/8 - 2-3/16	60-55mm	TWR2-060055	2-3/8 - 2	60-50mm	TWR2-060050	2-3/8 - 1-13/16	60-46mm	TWR2-060046
TWLC4	TWL4-041	1-5/8	41	1-5/8 - 1-7/16	41-36mm	TWR4-041036	1-5/8 - 1-1/4	41-32mm	TWR4-041032	-	-	-
	TWL4-046	1-13/16	46	1-13/16 - 1-5/8	46-41mm	TWR4-046041	1-13/16 - 1-7/16	46-36mm	TWR4-046036	1-13/16 - 1-1/4	46-32mm	TWR4-046032
	TWL4-050	2	50	2 - 1-13/16	50-46mm	TWR4-050046	2 - 1-5/8	50-41mm	TWR4-050041	2 - 1-7/16	50-36mm	TWR4-050036
	TWL4-055	2-3/16	55	2-3/16 - 2	55-50mm	TWR4-055050	2-3/16 - 1-13/16	55-46mm	TWR4-055046	2-3/16 - 1-5/8	55-41mm	TWR4-055041
	TWL4-060	2-3/8	60	2-3/8 - 2-3/16	60-55mm	TWR4-060055	2-3/8 - 2	60-50mm	TWR4-060050	2-3/8 - 1-13/16	60-46mm	TWR4-060046
	TWL4-065	2-9/16	65	2-9/16 - 2-3/8	65-60mm	TWR4-065060	2-9/16 - 2-3/16	65-55mm	TWR4-065055	2-9/16 - 2	65-50mm	TWR4-065050
	TWL4-070	2-3/4	70	2-3/4 - 2-9/16	70-65mm	TWR4-070065	2-3/4 - 2-3/8	70-60mm	TWR4-070060	2-3/4 - 2-3/16	70-55mm	TWR4-070055
	TWL4-075	2-15/16	75	2-15/16 - 2-3/4	75-70mm	TWR4-075070	2-15/16 - 2-9/16	75-65mm	TWR4-075065	2-15/16 - 2-3/8	75-60mm	TWR4-075060
	TWL4-080	3-1/8	80	3-1/8 - 2-15/16	80-75mm	TWR4-080075	3-1/8 - 2-3/4	80-70mm	TWR4-080070	3-1/8 - 2-9/16	80-65mm	TWR4-080065
TWLC8	TWL8-060	2-3/8	60	2-3/8 - 2-3/16	60-55mm	TWR8-060055	2-3/8 - 2	60-50mm	TWR8-060050	2-3/8 - 1-13/16	60-46mm	TWR8-060046
	TWL8-065	2-9/16	65	2-9/16 - 2-3/8	65-60mm	TWR8-065060	2-9/16 - 2-3/16	65-55mm	TWR8-065055	2-9/16 - 2	65-50mm	TWR8-065050
	TWL8-070	2-3/4	70	2-3/4 - 2-9/16	70-65mm	TWR8-070065	2-3/4 - 2-3/8	70-60mm	TWR8-070060	2-3/4 - 2-3/16	70-55mm	TWR8-070055
	TWL8-075	2-15/16	75	2-15/16 - 2-3/4	75-70mm	TWR8-075070	2-15/16 - 2-9/16	75-65mm	TWR8-075065	2-15/16 - 2-3/8	75-60mm	TWR8-075060
	TWL8-080	3-1/8	80	3-1/8 - 2-15/16	80-75mm	TWR8-080075	3-1/8 - 2-3/4	80-70mm	TWR8-080070	3-1/8 - 2-9/16	80-65mm	TWR8-080065
	TWL8-085	3-3/8	85	3-3/8 - 3-1/8	85-80mm	TWR8-085080	3-3/8 - 2-15/16	85-65mm	TWR8-085065	3-3/8 - 2-3/4	85-70mm	TWR8-085070
	TWL8-090	3-1/2	90	3-1/2 - 3-3/8	90-85mm	TWR8-090085	3-1/2 - 3-1/8	90-80mm	TWR8-090080	3-1/2 - 2-15/16	90-75mm	TWR8-090075
	TWL8-095	3-3/4	95	3-3/4 - 3-1/2	95-90mm	TWR8-095090	3-3/4 - 3-3/8	95-85mm	TWR8-095085	3-3/4 - 3-1/8	95-80mm	TWR8-095080
	TWL8-100	3-7/8	100	3-7/8 - 3-3/4	100-95mm	TWR8-100095	3-7/8 - 3-1/2	100-90mm	TWR8-100090	3-7/8 - 3-3/8	100-85mm	TWR8-100085

12 point links available upon request. Please contact factory.

## Ordering Information

### TO SPECIFY A TWLC SOLUTION:

1. Find a link for your application (nut size) (page 28-29)
2. Choose the appropriate Drive body (page 27)
3. Add reducers for additional nut sizes (pages 30-31)

Please order Drive Body and Link separately and pay attention to the same size, for Example TWLC2 and TWL2-041.



### Specifications and Dimensional Data

Body	Link	Nut A/F		Reducer			Reducer			Reducer		
		Order No.	Order No.	in	mm	in	mm	Order No.	in	mm	Order No.	in
TWLC15	TWL15-070	2-3/4	70	2-3/4 - 2-9/16	70 - 65mm	TWR15-070065	2-3/4 - 2-3/8	70-60mm	TWR15-070060	2-3/4 - 2-3/16	70-55mm	TWR15-070055
	TWL15-075	2-15/16	75	2-15/16 - 2-3/4	75-70mm	TWR15-075070	2-15/16 - 2-9/16	75-65mm	TWR15-075065	2-15/16 - 2-3/8	75-60mm	TWR15-075060
	TWL15-080	3-1/8	80	3-1/8 - 2-15/16	80-75mm	TWR15-080075	3-1/8 - 2-3/4	80-70mm	TWR15-080070	3-1/8 - 2-9/16	80-65mm	TWR15-080065
	TWL15-085	3-3/8	85	3-3/8 - 3-1/8	85-80mm	TWR15-085080	3-3/8 - 2-15/16	85-65mm	TWR15-085065	3-3/8 - 2-3/4	85-70mm	TWR15-085070
	TWL15-090	3-1/2	90	3-1/2 - 3-3/8	90-85mm	TWR15-090085	3-1/2 - 3-1/8	90-80mm	TWR15-090080	3-1/2 - 2-15/16	90-75mm	TWR15-090075
	TWL15-095	3-3/4	95	3-3/4 - 3-1/2	95-90mm	TWR15-095090	3-3/4 - 3-3/8	95-85mm	TWR15-095085	3-3/4 - 3-1/8	95-80mm	TWR15-095080
	TWL15-100	3-7/8	100	3-7/8 - 3-3/4	100-95mm	TWR15-100095	3-7/8 - 3-1/2	100-90mm	TWR15-100090	3-7/8 - 3-3/8	100-85mm	TWR15-100085
	TWL15-105	-	105	-	105-100mm	TWR15-105100	-	105-95mm	TWR15-105095	-	105-90mm	TWR15-105090
	TWL15-425	4-1/4	-	4-1/4 - 3-7/8	-	TWR15-425388	4-1/4 - 3-3/4	-	TWR15-425375	4-1/4 - 3-1/2	-	TWR15-425350
	TWL15-110	-	110	-	110-105mm	TWR15-110105	-	110-100mm	TWR15-110010	-	110-95mm	TWR15-110095
	TWL15-115	-	115	-	115-110mm	TWR15-115110	-	115-105mm	TWR15-115105	-	115-100mm	TWR15-115100
TWL15-463	4-5/8	-	4-5/8 - 4-1/4	-	TWR15-463425	4-5/8 - 3-7/8	-	TWR15-463388	4-5/8 - 3-3/4	-	TWR15-463375	
TWLC30	TWL30-080	3-1/8	80	3-1/8 - 2-15/16	80-75mm	TWR30-080075	3-1/8 - 2-3/4	80-70mm	TWR30-080070	3-1/8 - 2-9/16	80-65mm	TWR30-080065
	TWL30-085	3-3/8	85	3-3/8 - 3-1/8	85-80mm	TWR30-085080	3-3/8 - 2-15/16	85-65mm	TWR30-085065	3-3/8 - 2-3/4	85-70mm	TWR30-085070
	TWL30-090	3-1/2	90	3-1/2 - 3-3/8	90-85mm	TWR30-090085	3-1/2 - 3-1/8	90-80mm	TWR30-090080	3-1/2 - 2-15/16	90-75mm	TWR30-090075
	TWL30-095	3-3/4	95	3-3/4 - 3-1/2	95-90mm	TWR30-095090	3-3/4 - 3-3/8	95-85mm	TWR30-095085	3-3/4 - 3-1/8	95-80mm	TWR30-095080
	TWL30-100	3-7/8	100	3-7/8 - 3-3/4	100-95mm	TWR30-100095	3-7/8 - 3-1/2	100-90mm	TWR30-100090	3-7/8 - 3-3/8	100-85mm	TWR30-100085
	TWL30-105	-	105	-	105-100mm	TWR30-105100	-	105-95mm	TWR30-105095	-	105-90mm	TWR30-105090
	TWL30-425	4-1/4	-	4-1/4 - 3-7/8	-	TWR30-425388	4-1/4 - 3-3/4	-	TWR30-425375	4-1/4 - 3-1/2	-	TWR30-425350
	TWL30-110	-	110	-	110-105mm	TWR30-110105	-	110-100mm	TWR30-110010	-	110-95mm	TWR30-110095
	TWL30-115	-	115	-	115-110mm	TWR30-115110	-	115-105mm	TWR30-115015	-	115-100mm	TWR30-115100
	TWL30-463	4-5/8	-	4-5/8 - 4-1/4	-	TWR30-463425	4-5/8 - 3-7/8	-	TWR30-463388	4-5/8 - 3-3/4	-	TWR30-463375
	TWL30-120	-	120	-	120-115mm	TWR30-120115	-	120-110mm	TWR30-120110	-	120-105mm	TWR30-120105
	TWL30-500	5	-	5 - 4-5/8	-	TWR30-500463	5 - 4-1/4	-	TWR30-500425	5 - 3-7/8	-	TWR30-500388
	TWL30-130	-	130	-	130-120mm	TWR30-130120	-	130-115mm	TWR30-130115	-	130-110mm	TWR30-130110
	TWL30-135	5-3/8	135	5-3/8 - 5	135-125mm	TWR30-135125	5-3/8 - 4-5/8	135-120mm	TWR30-135120	5-3/8 - 4-1/4	135-115mm	TWR30-135115
	TWL30-145	5-3/4	145	AVAILABLE UPON REQUEST								
TWL30-150	-	150										
TWL30-155	6-1/8	155										

# TORQUE WRENCH REACTION ARMS - TWLC

SPX Bolting Systems offer a varied range of alternative and optional reaction accessories, which help to find a reaction point solution no matter how unusual the bolted application is.

## TWLC REACTION BAR TWLC-RB



- In-Line Extension Reaction Bar for TWLC wrench: allows extended reach on the same plane
- Pin engagement, no tools required
- Available for full range of tool sizes

### Specifications and Dimensional Data

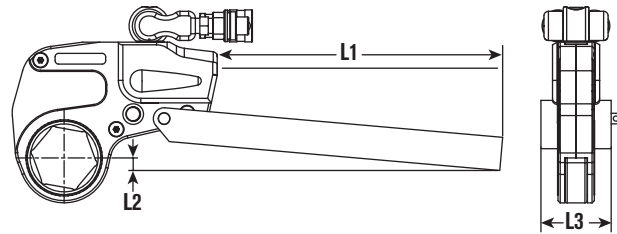

Tool Ref	Order No.	L1		L2		L3	
		mm	in	mm	in	mm	in
TWLC2	TWLC2-RB	381	15	28	1.10	55	2.17
TWLC4	TWLC4-RB	457	18	35	1.38	66	2.60
TWLC8	TWLC8-RB	457	18	37	1.46	85	3.35
TWLC15	TWLC15-RB	508	20	40	1.57	102	4.01
TWLC30	TWLC30-RB	508	20	35	1.38	127	5

## TWLC REACTION PADDLE TWLC-RP



- Off-Set Reaction Arm for TWLC wrench: allows off-set reaction within wrench profile
- Pin engagement, no tools required
- Light alloy construction
- Available for full range of tool

### Specifications and Dimensional Data

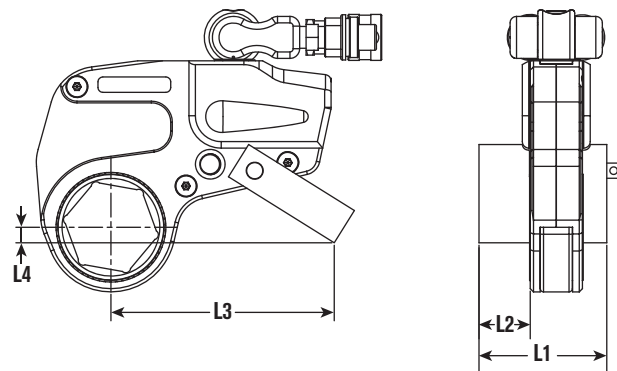

Tool Ref	Order No.	L1		L2		L3		L4	
		mm	in	mm	in	mm	in	mm	in
TWLC2	TWLC2-RP	84	3.31	35	1.38	142	5.59	13	0.51
TWLC4	TWLC4-RP	109	4.29	46	1.81	178	7.01	19	0.75
TWLC8	TWLC8-RP	136.5	5.37	57	2.25	220	8.66	26	1.02
TWLC15	TWLC15-RP	165	6.50	70	2.76	252	9.92	45	1.77
TWLC30	TWLC30-RP	200	7.874	86	3.39	317	12.48	44	1.73



**HAVE A UNIQUE APPLICATION?  
DOES STANDARD PRODUCT NOT FIT?**



**CUSTOM REACTION PADS AND REDUCERS ARE AVAILABLE.**

Contact SPX or an authorized distributor for more details

**WHEN NOTHING ELSE WILL WORK,  
SPLIT ADAPTERS ARE MADE TO  
ORDER AND AVAILABLE UPON  
REQUEST.**



TWLC15 split adapter,  
closed position



TWLC15 split adapter,  
open position

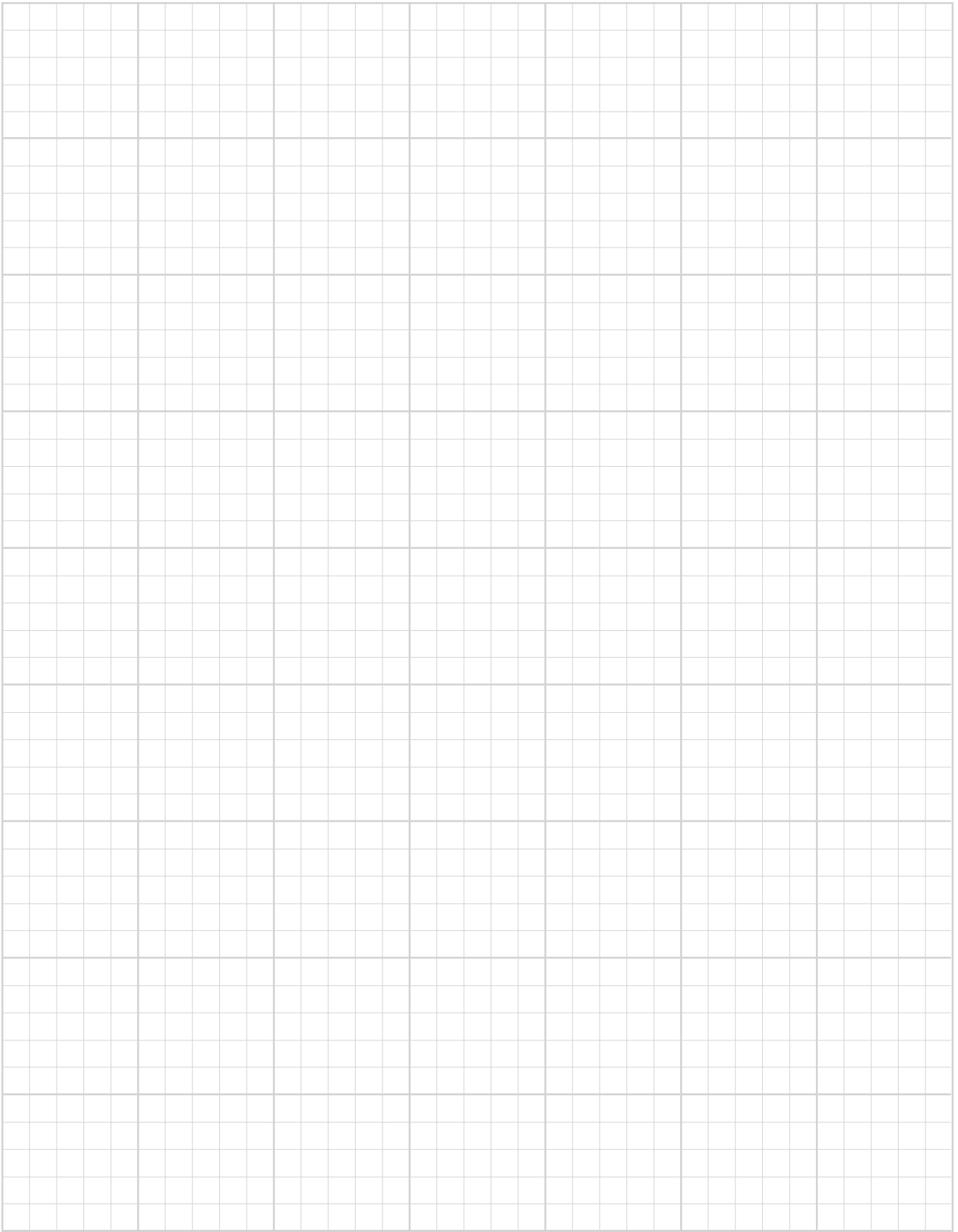

# TENSIONERS

## HIGH PERFORMANCE TENSIONERS

Page  
**SRT**  
**ADVANTAGES...36**



Page  
**SRT...35-39**  
Spring Return Tensioner



Page  
**MRT...40-41**  
Manual Return Tensioner



Page  
**WD/WS...42**  
Wind Tensioners



Page  
**WDD...43**  
Up Tower Wind Tensioners



Page  
**WSD...44**  
Compact Tower Wind Tensioners



Page  
**WSS/WSL...45**  
Foundation Wind Tensioners



Page  
**SST...58-59**  
Subsea Tensioners



# SRT ADVANTAGES

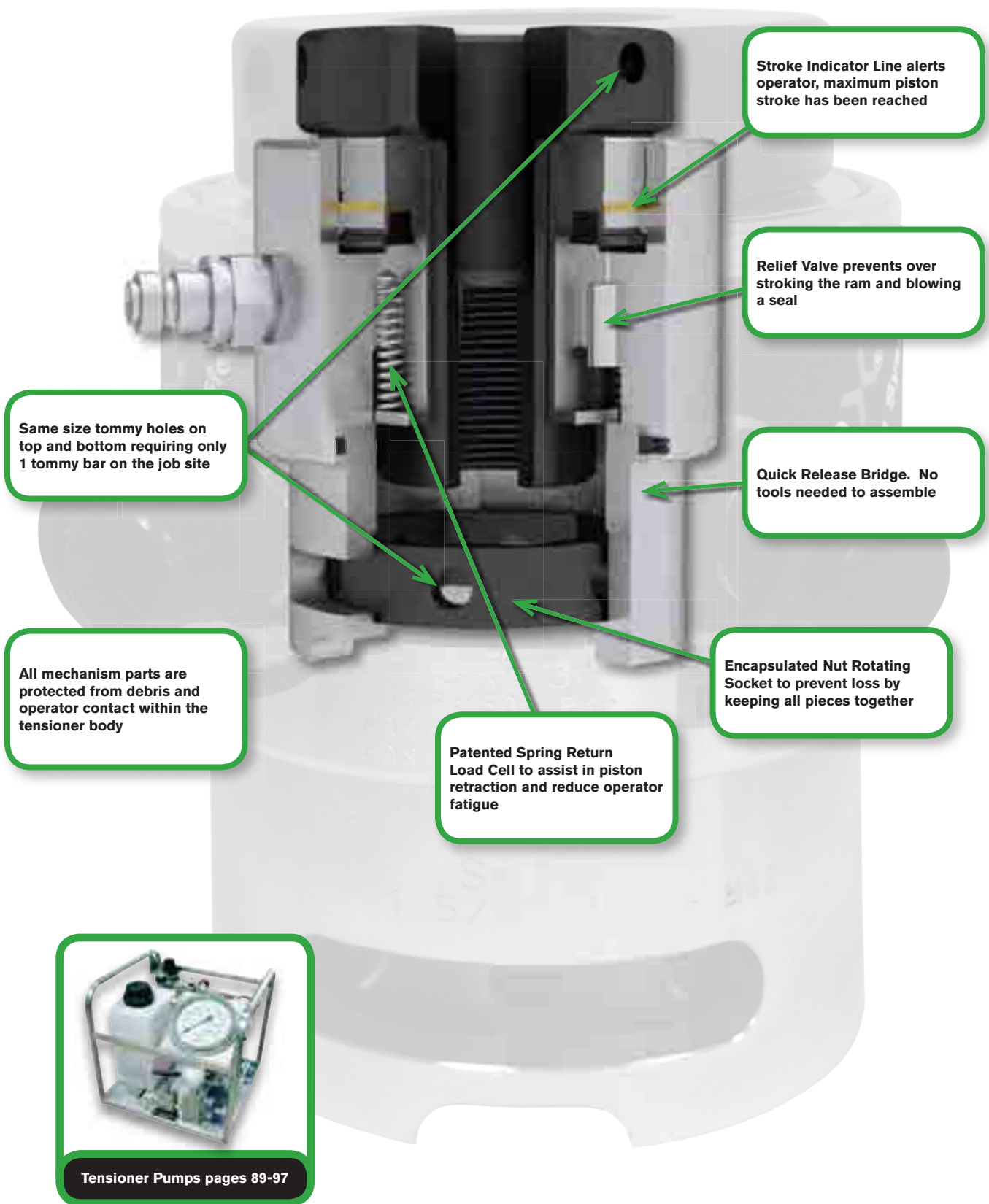

## SRT SPRING RETURN BOLT TENSIONER

The Spring Return design dramatically increases productivity and safety on the job site when compared to older technology manual return tensioners.

- Piston overstroke prevention
- Piston stroke indication
- Compatible with MRT Tensioner range
- Unique quick release bridge adaptation
- Piston/cylinder misalignment compensation
- Bolt coverage from 3/4" to 4" (20 - 115 mm) with just 8 tools
- Designed to fit BS1560 / ANSI B16.5 / API flanges
- Fully enclosed load cell design eliminates entry of debris into piston retraction mechanism
- Piston over-stroke eliminator to prevent over stroking and blowing a seal
- Twin hydraulic couplings for multiple tool connections
- Requires stud to protrude above nut by 1 x bolt diameter
- Application specific tooling available. Contact factory for details.
- 10 mm piston stroke

**Max tool pressure:** 1,500 bar (21,750 psi)

**Bolt protrusion above nut:** 1 x bolt diameter (minimum)

## BOLT TENSIONER SPRING RETURN - SRT

Bolt coverage from 3/4" to 4"  
(20 - 115 mm) with just 8 tools



# BOLT TENSIONER SPRING RETURN - SRT

Bolt coverage from 3/4" to 4"  
(20 - 115 mm) with just 8 tools



**Piston stroke:** 10mm

**Max tool pressure:** 1,500 bar (21,750 psi)

**Bolt protrusion above nut:** 1 x bolt diameter

## Specifications and Dimensional Data

Tool Ref	Stud Diameter				Tool Load		Hydraulic Area		Approx Wt.		Minimum Bolt Protrusion Above Nut				
	Load Cell Order No.	Imperial	Adaptor Kit Order No.	Metric	Adapter Kit Order No.	Lbf	kN	in <sup>2</sup>	mm <sup>2</sup>	lb	kg	Imp bolts		met bolts	
												in	mm	in	mm
SRT0 SRTAS000001		3/4"	SRTAS000002	M20	SRTAS000006	35,971	160	1.654	1,067	3.1	1.4	0.75	19	0.79	20
		7/8"	SRTAS000004	M22	SRTAS000008							0.87	22	0.87	22
SRT1 SRTAS010001		1"	SRTAS010003	M24	SRTAS010007	62,950	280	2.894	1,867	6	2.7	0.98	25	0.94	24
		-	-	M27	SRTAS010009							-	-	1.06	27
SRT2 SRTAS020001		1-1/8"	SRTAS010005	-	-	101,169	450	4.652	3,001	9	4.1	1.14	29	-	-
		1"	SRTAS020003	M24	SRTAS020011							0.98	25	0.94	24
		-	-	M27	SRTAS020013							-	-	1.06	27
		1-1/4"	SRTAS020005	M30	SRTAS020014							1.14	29	1.18	30
		1-1/4"	SRTAS020007	M33	SRTAS020015							1.26	32	1.30	33
SRT3 SRTAS030001		1-3/8"	SRTAS020009	M36	SRTAS020016	148,381	660	6.822	4,401	11.9	5.4	1.38	35	1.42	36
		1-1/4"	SRTAS030003	M33	SRTAS030011							1.26	32	1.30	33
		1-3/8"	SRTAS030005	M36	SRTAS030012							1.38	35	1.42	36
		1-1/2"	SRTAS030007	M39	SRTAS030013							1.5	38	1.54	39
SRT4 SRTAS040001		1-5/8"	SRTAS030009	M42	SRTAS030014	224,820	1000	10.335	6,668	18.5	8.4	1.61	41	1.65	42
		1-1/2"	SRTAS040004	M39	SRTAS040014							1.5	38	1.54	39
		1-5/8"	SRTAS040006	M42	SRTAS040015							1.61	41	1.65	42
		1-3/4"	SRTAS040008	M45	SRTAS040016							1.73	44	1.77	45
		1-7/8"	SRTAS040010	M48	SRTAS040017							1.89	48	1.89	48
SRT5 SRTAS050001		2"	SRTAS040012	-	-	337,230	1500	15.504	10,003	30.4	13.8	2.01	51	-	-
		2"	SRTAS050004	M52	SRTAS050012							2.01	51	2.05	52
		2-1/4"	SRTAS050006	M56	SRTAS050013							2.24	57	2.20	56
		-	-	M60	SRTAS050015							-	-	2.36	60
		2-1/2"	SRTAS050008	M64	SRTAS050016							2.52	64	2.52	64
		-	-	M68	SRTAS050018							-	-	2.68	68
SRT6 SRTAS060001		-	-	M70	SRTAS050020	562,050	2500	25.84	16,671	50.7	23	-	-	2.76	70
		2-3/4"	SRTAS050010	-	-							2.76	70	-	-
		2-3/4"	SRTAS060004	M72	SRTAS060014							2.76	70	2.83	72
		3"	SRTAS060006	M76	SRTAS060016							2.99	76	2.99	76
		-	-	M80	SRTAS060018							-	-	3.15	80
SRT7 SRTAS070001		3-1/4"	SRTAS060008	M85	SRTAS060020	719,424	3200	33.076	21,339	70.5	32	3.27	83	3.35	85
		3-1/2"	SRTAS060010	M90	SRTAS060022							3.50	89	3.54	90
		3-1/2"	SRTAS070004	M90	SRTAS070010							3.50	89	3.54	90
		-	-	M95	SRTAS070012							-	-	3.74	95
SRT8 SRTAS080001		3-3/4"	SRTAS070006	M100	SRTAS070014	921,762	4100	42.377	27,340	99.2	45	3.74	95	3.94	100
		4"	SRTAS070008	-	-							4.02	102	-	-
		4"	SRTAS080004	M105	SRTAS080010							4.02	102	4.13	105
		-	-	M110	SRTAS080012							-	-	4.33	110
SRT8 SRTAS080001		4-1/4"	SRTAS080006	M115	SRTAS080014	921,762	4100	42.377	27,340	99.2	45	4.25	108	4.53	115
		4-1/2"	SRTAS080008	-	-							4.49	114	-	-

Weight excludes puller sleeve

Need to order load cell and adapter kit to have complete tensioner

To convert to long tons, divide lbf by 2240. To convert to short tons, divide lbf by 2000.

All bolt diameters ≤ 1" are UNC and all diameters > 1" are 8UN. All metric threads are Metric Coarse.

## Specifications and Dimensional Data

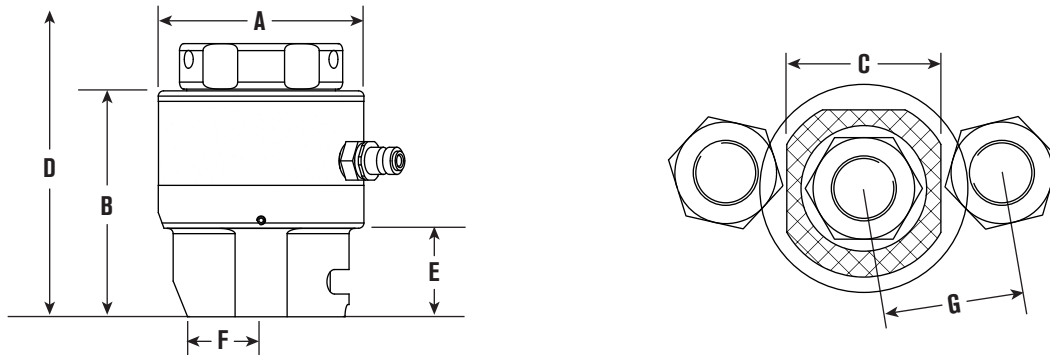

'D' includes an allowance for tool removal after bolt tightening with 10 mm tool stroke

A		B		C		D				E		F		G				Stud Diameter		Tool Ref
						Imp bolts		met bolts						Imp bolts		met bolts		Imperial	Metric	Load Cell Order No.
in	mm	in	mm	in	mm	in	mm	in	mm	in	mm	in	mm	in	mm	in	mm			
2.6	66	3.7	93	2.5	63	5.4	136	5.6	142	1.4	36	1	25	2	50.8	2	49.8	3/4"	M20	SRT0
		3.7	93	2.5	63	5.6	142	5.7	144	1.4	36	1	25	2.1	53.6	2	51	7/8"	M22	SRTAS000001
3.4	87	4.6	117	2.7	68	6.9	175	6.9	175	1.5	38	1.1	28	2.3	58.8	2.2	56.5	1"	M24	SRT1
		4.6	117	2.7	68	-	-	7	178	1.5	38	1.1	28	-	-	2.3	58.7	-	M27	SRTAS010001
		4.7	120	2.8	72	7.1	181	-	-	1.6	41	1.2	31	2.7	68.3	-	44.5	1-1/8"	-	-
4.1	103	4.6	117	3	75	6.9	175	6.9	175	1.5	38	1.2	30	2.6	65.2	2.5	64.5	1"	M24	SRT2
		4.6	117	3	75	-	-	7	178	1.5	38	1.2	30	-	-	2.6	66	-	M27	
		4.7	120	3.1	80	7.1	181	7.2	184	1.6	41	1.2	30	2.7	67.6	2.7	67.6	1-1/8"	M30	SRTAS020001
		4.8	123	3.3	84	7.4	188	7.5	190	1.7	44	1.4	35	2.8	72.3	2.8	71.9	1-1/4"	M33	
		5	126	3.5	89	7.7	195	7.7	196	1.9	47	1.5	38	3.1	78	3	77	1-3/8"	M36	
4.7	118	4.8	123	3.5	88	7.5	190	7.6	192	1.7	44	1.4	35	3	75.9	3	76.5	1-1/4"	M33	SRT3
		5	126	3.8	96	7.8	197	7.8	198	1.9	47	1.5	38	3.2	81.1	3.2	80.8	1-3/8"	M36	
		5.1	130	3.8	96	8	203	8	204	2	51	1.7	42	3.3	83.8	3.3	83.6	1-1/2"	M39	SRTAS030001
		5.2	133	4.1	105	8.2	209	8.3	211	2.1	54	1.6	41	3.6	91	3.6	91	1-5/8"	M42	
5.5	140.5	5.2	132	4.4	112	8.3	211	8.3	212	2	51	1.7	42	3.6	91.8	3.6	91.6	1-1/2"	M39	SRT4
		5.3	135	4.5	114	8.5	217	8.6	218	2.1	54	1.8	45	3.8	95.6	3.8	95.5	1-5/8"	M42	
		5.5	139	4.6	118	8.8	223	8.9	225	2.2	57	2	52	3.9	100	3.9	100	1-3/4"	M45	
		5.6	142	4.5	114	9.1	230	9.1	231	2.4	60	2	51	4	101.1	4	101.3	1-7/8"	M48	
		5.7	145	4.7	120	9.3	236	-	-	2.5	63	2	52	4.2	106.8	-	-	2"	-	
6.9	175.5	5.8	148	4.7	120	9.7	246	9.8	248	2.5	63	2	52	4.5	114	4.5	115	2"	M52	SRT5
		6.1	154	5.4	138	10.2	259	10.2	258	2.8	70	2.3	58	4.8	121.3	4.7	119.1	2-1/4"	M56	
		6.3	161	5.4	138	-	-	10.3	262	2.8	70	2.3	58	-	-	4.8	122	-	M60	
		6.3	161	6	153	10.7	272	10.7	273	3	76	2.5	63	5.3	134.3	5.2	132.3	2-1/2"	M64	
		6.3	161	6	153	-	-	11.1	283	3	76	2.5	63	-	-	5.3	135	-	M68	
		6.3	161	6	153	-	-	11.3	287	3	76	2.5	63	-	-	5.3	135.2	-	M70	
		6.6	167	6.1	156	11.2	284	11.1	283	3.2	81	2.8	70	5.6	141.3	-	-	2-3/4"	-	
		6.6	167	6.2	157	11.6	294	11.7	297	3.2	82	2.8	72	5.7	145.4	5.8	146.5	2-3/4"	M72	
8.6	219	6.9	174	7.2	182	12.1	307	12.1	308	3.5	89	3.1	80	6.3	159.8	6.1	155.5	3"	M76	SRT6
		6.9	174	7.2	182	-	-	12.3	312	3.5	89	3.1	80	-	-	6.2	158.4	-	M80	
		7.1	180	7.5	190	12.6	320	12.7	323	3.7	95	3.3	84	6.7	169	6.5	165	3-1/4"	M85	
		7.3	186	8.1	205	13.1	332	13.1	334	4	101	3.5	88	7.2	182	7	178.6	3-1/2"	M90	
		7.3	186	7.9	200	13.3	339	13.4	341	4	101	3.5	88	7.1	179.8	6.9	176.1	3-1/2"	M90	
9.9	252	7.3	186	7.9	200	-	-	13.6	346	4	101	3.5	88	-	-	7	178.9	-	M95	SRT7
		7.6	192	7.9	200	13.9	352	14	356	4.2	107	3.7	94	7.3	185.3	7.3	184.7	3-3/4"	M100	
		7.8	199	8.3	210	14.3	364	-	-	4.5	114	4.5	114	7.3	186	-	-	4"	-	
		7.8	199	8.3	210	14.7	374	14.9	378	4.5	114	4.5	114	7.7	196	7.7	195	4"	M105	
11.1	282	7.8	199	8.3	210	-	-	15.1	383	4.5	114	4.5	114	-	-	7.8	197	-	M110	SRT8
		8.1	205	8.8	224	15.2	387	15.5	394	4.7	120	4.5	114	8.2	208	8.2	208	4-1/4"	M115	
		8.3	212	9.1	232	15.7	400	-	-	5	127	4.6	117	8.6	218	-	-	4-1/2"	-	

# BOLT TENSIONER

## MANUAL RETURN - MRT

Bolt coverage from 1" to 3-1/2"  
(24 - 100mm) with just 6 tools



# MRT MANUAL RETURN BOLT TENSIONER

Our economy range of bolt tensioners offer low-cost tensioning solutions.

Incorporating our unique quick-release bridge adaptation, a range of adapter kits provide maximum flexibility.

- Piston stroke limit indication
- Piston / cylinder misalignment compensation
- Bolt coverage from 1" to 3-1/2" with just 6 tools
- Designed to fit BS1560 / ANSI B16.5 / API flanges
- Unique quick-release bridge adaption
- Application specific tooling available. Contact factory for details.

### Specifications and Dimensional Data

Tool Ref	Stud Diameter				Tool Load		Hydraulic Area		Approx Wt.		Minimum Bolt Protrusion Above Nut				
	Load Cell Order No.	Imperial	Adaptor Kit Order No.	Metric	Adaptor Kit Order No.	Lbf	kN	in <sup>2</sup>	mm <sup>2</sup>	lb	kg	Imp bolts		met bolts	
												in	mm	in	mm
MRT1 MRTAS010001		1"	MRTAS010002	M24	MRTAS010004	62,900	280	2.894	1,867	6.6	3	0.98	25	0.94	24
		-	-	M27	MRTAS010005							-	-	1.06	27
		1-1/8"	MRTAS010003	-	-							1.14	29	-	-
MRT2 MRTAS020001		1"	MRTAS020002	M24	MRTAS020006	101,100	450	4.652	3,001	9.9	4.5	0.98	25	0.94	24
		-	-	M27	MRTAS020007							-	-	1.06	27
		1-1/8"	MRTAS020003	M30	MRTAS020008							1.14	29	1.18	30
		1-1/4"	MRTAS020004	M33	MRTAS020009							1.26	32	1.30	33
		1-3/8"	MRTAS020005	M36	MRTAS020010							1.38	35	1.42	36
MRT3 MRTAS030001		1-1/4"	MRTAS030002	M33	MRTAS030006	148,300	660	6.822	4,401	12.98	5.9	1.26	32	1.30	33
		1-3/8"	MRTAS030003	M36	MRTAS030007							1.38	35	1.42	36
		1-1/2"	MRTAS030004	M39	MRTAS030008							1.50	38	1.54	39
		1-5/8"	MRTAS030005	M42	MRTAS030009							1.61	41	1.65	42
MRT4 MRTAS040001		1-1/4"	MRTAS040003	M39	MRTAS040008	224,700	1,000	10.335	6,668	18.7	8.5	1.26	32	1.54	39
		1-5/8"	MRTAS040004	M42	MRTAS040009							1.61	41	1.65	42
		1-3/4"	MRTAS040005	M45	MRTAS040010							1.73	44	1.77	45
		1-7/8"	MRTAS040006	M48	MRTAS040011							1.89	48	1.89	48
		2"	MRTAS040007	-	-							2.01	51	-	-
MRT5 MRTAS050001		2"	MRTAS050003	M52	MRTAS050007	337,200	1,500	15.505	10,003	30.8	14	2.01	51	2.05	52
		2-1/4"	MRTAS050004	M56	MRTAS050008							2.24	57	2.20	56
		-	-	M60	MRTAS050009							-	-	2.36	60
		2-1/2"	MRTAS050005	M64	MRTAS050010							2.52	64	2.52	64
		-	-	M68	MRTAS050011							-	-	2.68	68
		-	-	M70	MRTAS050012							-	-	2.76	70
		2-3/4"	MRTAS050006	-	-							2.76	70	-	-
MRT6 MRTAS060001		2-3/4"	MRTAS060003	M72	MRTAS060007	562,000	2,500	25.84	16,671	50.6	23	2.01	51	2.83	72
		3"	MRTAS060004	M76	MRTAS060008							2.99	76	2.99	76
		-	-	M80	MRTAS060009							-	-	3.15	80
		3-1/4"	MRTAS060005	M85	MRTAS060010							3.27	83	3.35	85
		3-1/2"	MRTAS060006	M90	MRTAS060011							3.50	89	3.54	90
MRT7 MRTAS070001		3-1/2"	MRTAS070003	M90	MRTAS070006	719,300	3,200	33	21,339	70.4	32	3.50	89	3.54	90
		-	-	M95	MRTAS070007							-	-	3.74	95
		3-3/4"	MRTAS070004	M100	MRTAS070008							3.74	95	3.94	100
		4"	MRTAS070005	-	-							4.02	102	-	-

To convert to long tons, divide lbf by 2240. To convert to short tons, divide lbf by 2000.



## Specifications and Dimensional Data

**Piston stroke:** 15mm (excluding MRT1 - 10mm)

**Max tool pressure:** 1,500 bar (21,750 psi)

**Bolt protrusion above nut:** 1 x bolt diameter

'D' includes an allowance for tool removal after bolt tightening with 15mm tool stroke

Weight excludes puller sleeve

To make a complete MRT Tensioner, choose an Adapter Kit and a Load Cell.

Semi-compatible with SRT tensioners. Only compatible with SRT Bridges; NOT puller sleeves. SRT Puller Sleeves cannot be used with MRT Load Cell.

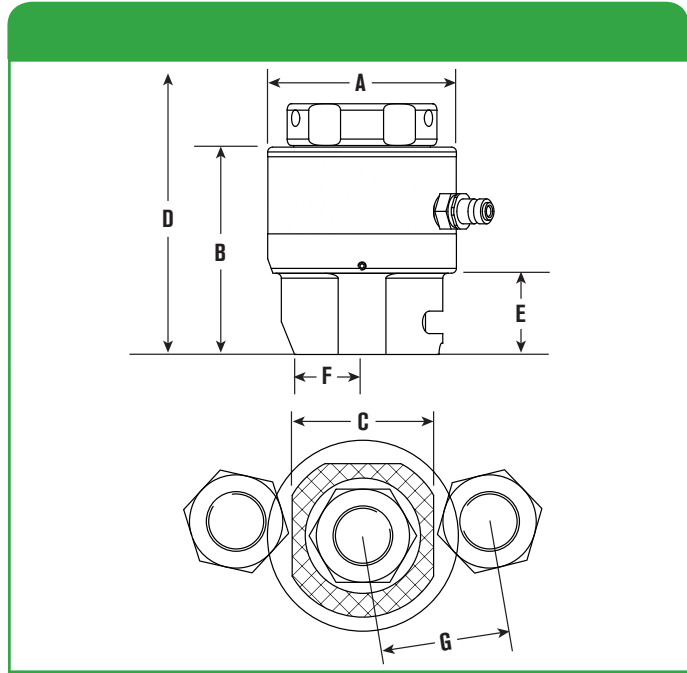

	A		B		C		D		E		F		G		Stud Diameter		Tool Ref Load Cell Order No.			
	in	mm	in	mm	in	mm	Imp bolts in	met bolts in	in	mm	in	mm	Imp bolts in	met bolts in	Imperial	Metric				
3.35	85	3.8	97	2.7	68	6.6	166.8	6.1	155.4	1.5	38	1.1	28	2.3	59	2.2	56	1"	M24	MRT1
		3.8	97	2.7	68	-	-	6.2	158.4	1.5	38	1.1	28	-	-	2.3	59	-	M27	MRTAS010001
		3.9	100	3	76	6.8	173.2	-	-	1.6	41	1.2	31	2.6	66	-	44	1-1/8"	-	
4.25	108	4	102.5	3	75	7.2	181.8	7.1	180.4	1.5	38	1.2	30	2.7	68	2.6	67	1"	M24	MRT2 MRTAS020001
		4	102.5	3	75	-	-	7.2	183.4	1.5	38	1.2	30	-	-	2.7	69	-	M27	
		4.2	105.5	3.1	80	7.4	188.2	7.5	189.6	1.6	41	1.2	30	2.7	69	2.8	70	1-1/8"	M30	
		4.3	108.5	3.3	84	7.7	194.5	7.7	195.8	1.7	44	1.4	35	2.8	72	2.8	72	1-1/4"	M33	
		4.4	111.5	3.5	89	7.9	200.9	7.9	201.9	1.9	47	1.5	38	3.1	78	3	77	1-3/8"	M36	
4.9	147.5	4.3	108.5	3.5	88	7.7	196.5	7.8	197.8	1.7	44	1.4	35	3.1	79	3.1	80	1-1/4"	M33	MRT3 MRTAS030001
		4.4	111.5	3.8	96	8	203	8	204	1.9	47	1.5	38	3.2	81	3.2	81	1-3/8"	M36	
		4.5	115	3.8	96	8.2	209.2	8.3	210.1	2	50.5	1.7	42	3.3	84	3.3	84	1-1/2"	M39	
		4.6	118	4.1	105	8.5	215.6	8.5	216.3	2.1	53.5	1.6	41	3.6	91	3.6	91	1-5/8"	M42	
5.8	147.5	4.6	116	4.4	112	8.5	215.2	8.5	216.1	2	50.5	1.7	42	3.7	94	3.7	94	1-1/4"	M39	MRT4 MRTAS040001
		4.7	119	4.5	114	8.7	222	8.7	222	2.1	53.5	1.8	45	3.8	96	3.8	96	1-5/8"	M42	
		4.8	122.5	4.6	118	9	227.9	9	228.5	2.2	57	2	52	3.9	100	3.9	100	1-3/4"	M45	
		4.9	125.5	4.5	114	9.2	234.3	9.2	234.6	2.4	60	2	51	4	101	4	101	1-7/8"	M48	
		5.1	128.5	4.7	120	9.5	241	-	-	2.5	63	2	52	4.2	107	-	-	2"	-	
7.1	180.5	5.2	132	4.7	120	9.9	250.6	9.9	251.8	2.5	63	2	52	4.6	117	4.6	117	2"	M52	MRT5 MRTAS050001
		5.5	138.5	5.4	138	10.4	263.3	10.3	262.2	2.7	69.5	2.3	58	4.8	121	4.7	119	2-1/4"	M56	
		5.5	138.5	5.4	138	-	-	10.5	266	2.7	69.5	2.3	58	-	-	4.8	122	-	M60	
		5.7	145	6	153	10.9	276	10.9	276.5	3	76	2.5	63	5.3	134	5.2	132	2-1/2"	M64	
		5.7	145	6	153	-	-	11	280.5	3	76	2.5	63	-	-	5.3	135	-	M68	
		5.7	145	6	153	-	-	11.1	282.5	3	76	2.5	63	-	-	5.3	135	-	M70	
8.9	227	5.9	150	6.1	156	11.4	289	-	-	3.2	81	2.8	70	5.6	141	-	-	2-3/4"	-	MRT6 MRTAS060001
		5.9	151	6.2	157	11.8	298.7	11.8	300.9	3.2	82	2.8	72	5.9	149	5.9	151	2-3/4"	M72	
		6.2	158	7.2	182	12.3	311.4	12.3	311.2	3.5	89	3.1	80	6.3	160	6.1	156	3"	M76	
		6.2	158	7.2	182	-	-	12.4	315.2	3.5	89	3.1	80	-	-	6.2	158	-	M80	
		6.5	164	7.5	190	12.8	324.1	12.9	326.6	3.7	95	3.3	84	6.7	169	6.5	165	3-1/4"	M85	
10	252	6.7	170	8.1	205	13.3	336.8	13.3	337.9	4	101	3.5	88	7.2	182	7	179	3-1/2"	M90	MRT7 MRTAS070001
		6.8	173	7.9	200	13.6	346	13.7	347	4	101	3.5	88	7.1	180	6.9	176	3-1/2"	M90	
		0	6.8	173	7.9	200	-	-	13.9	351.9	101	3.5	88	-	-	7	179	-	M95	
		0	7	179	7.9	200	14.1	358.5	14.3	363.3	107	3.7	94	7.3	185	7.3	185	3-3/4"	M100	
		0	7.3	186	8.3	210	14.6	371.2	-	-	114	4.5	114	7.5	190	-	-	4"	-	

For smaller or larger sizes, see SRT product pages.

## WIND TENSIONERS

WD / WS



WDD



WSS & WSL



WSD



## WIND TENSIONERS

Our tensioners have quality designed in with standard features that enhance durability and efficiency to get the job done faster and safer:

### Quality Means Lower Life-Cycle Costs:

- Achieves 90% proof load requirement for ISO 898 Grade 10.9 bolts
- Fully enclosed load cell eliminates debris in piston retraction mechanism
- Auto-Engaging Geared Nut Rotator
- Self-energizing, long life seals

### Enhanced Usability:

- Piston stroke limit indication
- High pressure swivel coupling (swivel is optional on WSS & WSL)
- 1,350 bar (19,580 psi maximum operating pressure)
- Automatic piston retraction mechanism

### Designed with Safety in Mind:

- Overstroke prevention for safe operation
- Anti-slip grip surface
- Tool lifting-strap as standard



# WIND TENSIONERS UP TOWER - WDD



## Specifications and Dimensional Data

### WDD UP TOWER WIND TENSIONERS

- Robust Gearbox Drive
- Auto-Engaging Geared Nut Rotator
- Small diameter, high load 2-Stage hydraulic load cell
- Fast application using 1/2" drive
- Cycle counter optional (Add "A" to end of part number)
- Max Pressure: 1,350 bar (19,580 psi)
- Twin coupling optional (Add "TC" to end of part number)

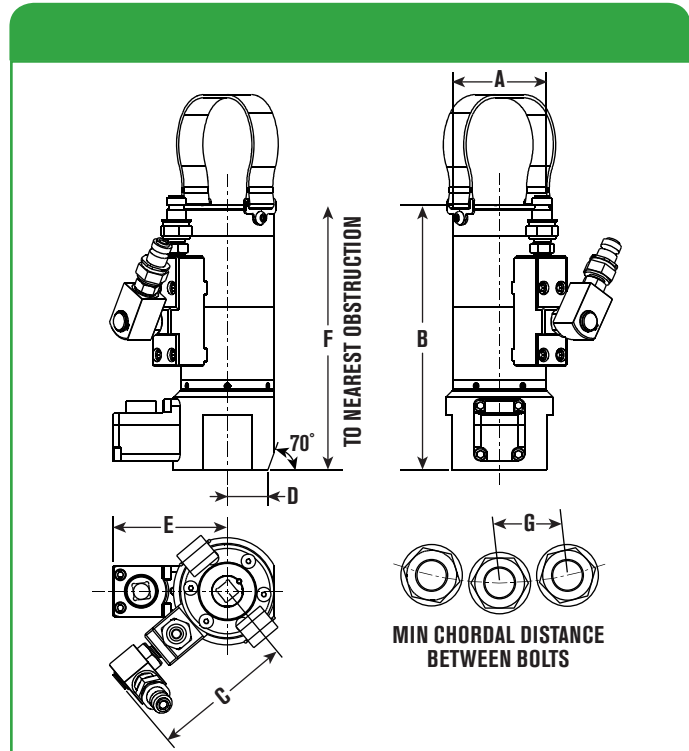

Tool Ref	A mm	B mm	C mm	D mm	E mm	F mm	G mm
WDD1-M30	74	210	112	37	91	290	64
WDD2-M33	79	214	115	39.5	93	298	70
WDD3-M36	85	239	117	42.5	96	332	76
WDD4-M39	92	249	121	46	99	348	79
WDD5-M42	98	255	124	49	102	360	90

### Ordering Information

Order No.	Metric	Required Thread Protrusion mm	Stroke mm	Max Load kN	Hyd Area sq. mm	Wt kg
WDD1-M30	M30	63 - 70	7	467	3458	6.70
WDD2-M33	M33	67 - 74	7	569	4215	7.60
WDD3-M36	M36	71 - 80	10	671	4970	9.25
WDD4-M39	M39	72 - 86	10	801	5931	11.10
WDD5-M42	M42	80 - 92	10	926	6856	12.60

For twin hydraulic couplings (for multiple tool connection) add "TC" after part number. For cycle counter option, add "A" after code (eg. WDD1-M30A, WDD1-M30TCA)

# WIND TENSIONERS

## COMPACT TOWER - WSD



### Specifications and Dimensional Data

#### WSD COMPACT TOWER WIND TENSIONERS

- Robust Gearbox Drive
- Auto-Engaging Geared Nut Rotator
- Low height hydraulic load cell
- Fast application using 1/2" drive
- Cycle counter optional (Add "A" to end of part number)
- Maximum operating pressure 1350 bar (19,580 psi)
- Twin coupling optional (Add "TC" to end of part number)

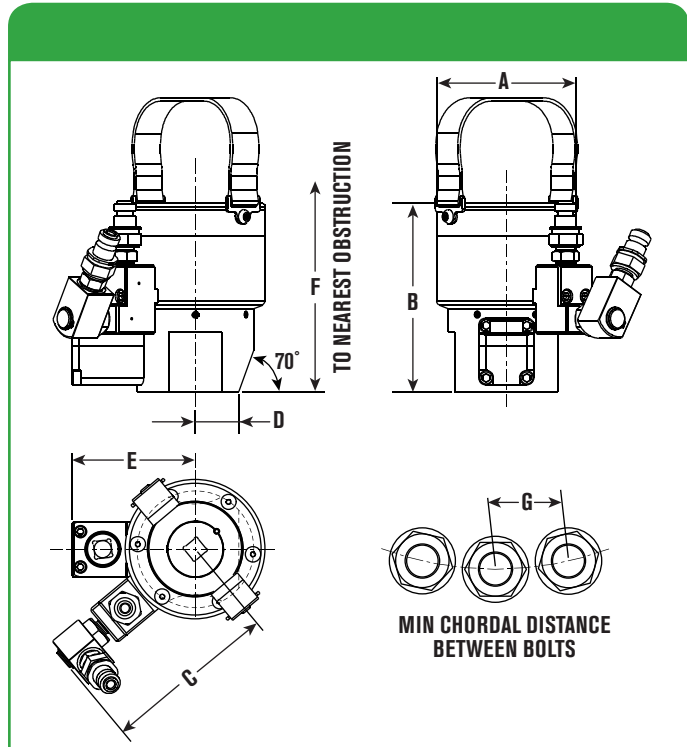

Tool Ref	A mm	B mm	C mm	D mm	E mm	F mm	G mm
WSD1-M30	103	138	127	32	91	211	68
WSD2-M33	112	140	132	35	93	218	74
WSD3-M36	122	149	136	37	96	233	82
WSD4-M39	133	153	142	42	99	238	88
WSD5-M42	140	157	146	45	102	250	93

#### Ordering Information

Order No.	Metric	Required Thread Protrusion mm	Stroke mm	Max Load kN	Hyd Area sq. mm	Wt kg
WSD1-M30	M30	63 - 81	7	467	3458	6.60
WSD2-M33	M33	67 - 86	7	569	4215	7.60
WSD3-M36	M36	71 - 93	10	671	4970	8.80
WSD4-M39	M39	72 - 95	10	801	5931	11.20
WSD5-M42	M42	80 - 96	10	926	6856	12.20

For twin hydraulic couplings (for multiple tool connection) add "TC" after part number. For cycle counter option, add "A" after code (eg. WDD1-M30A, WDD1-M30TCA)

# WSS & WSL FOUNDATION WIND TENSIONERS

- Suitable for ISO Metric threaded and all-thread bars
- Geared or Manual Nut Rotator
- Long & short stroke models
- High pressure swivel coupling (optional)
- Maximum operating pressure 1350 bar (19,580 psi)
- Uses standard system 'nut' for reaction



# WIND TENSIONERS FOUNDATION - WSS & WSL

- Need to order load cell and adaptor kit to have complete tensioner

## Specifications and Dimensional Data

### Manual Nut Rotation Version

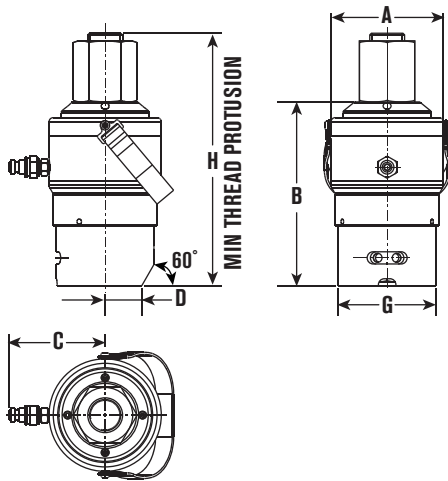

### Gearbox Nut Rotation Version

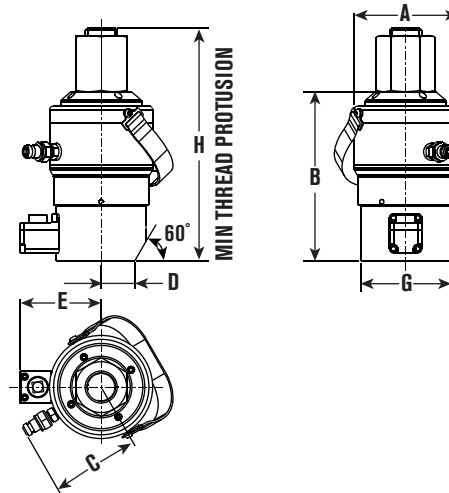

Tool Ref	A mm	B mm	C mm	D mm	E mm	G mm	H mm
WSS1/WSS1-10	103	158	98	42	99	103	206
WSS1/WSS1-11	103	158	98	42	99	103	219
WSL1/WSL1-10	114	205	103	42	99	130	255
WSL1/WSL1-11	114	205	103	42	99	103	266
WSS2/WSS2-125	119	168	105	42	102	112	226
WSS2/WSS2-138	119	168	105	42	102	112	238
WSL2/WSL2-125	129	211	110	42	102	112	269
WSL2/WSL2-138	129	211	110	42	102	112	280

## Ordering Information

Load Cell Order No.	Adaptor Kit** Order No.	Bar Size	Stroke mm	Max Load kN	Hyd Area sq mm	Wt kg
<b>FOR GRADE 75 ksi ALL THREAD FOUNDATION BOLTS</b>						
WSS1	WSS1-10	#10	10	470	3481	5.74
	WSS1-11	#11				5.85
WSL1	WSL1-10	#10	25	470	3481	9.00
	WSL1-11	#11				9.20
<b>FOR GRADE 150 ksi ALL THREAD FOUNDATION BOLTS</b>						
WSS2	WSS2-125	1-1/4"	10	760	5630	8.20
	WSS2-138	1-3/8"				8.30
WSL2	WSL2-125	1-1/4"	25	760	5630	12.30
	WSL2-138	1-3/8"				12.40

\*\*For manual nut rotation Adaptor Kit add "M" after part number, for gearbox style nut rotation add "GB".

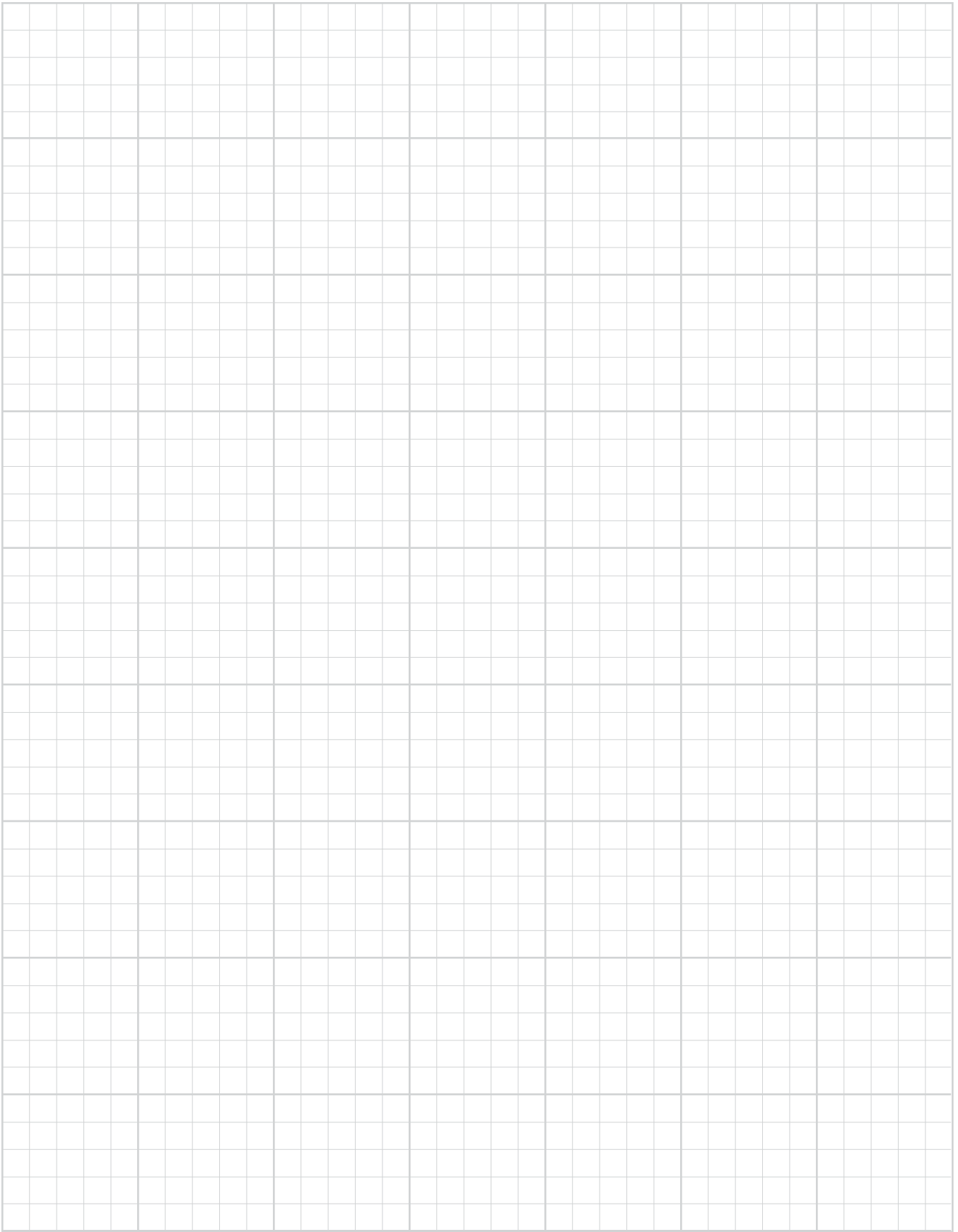

# OTHER TOOLS

## HIGH PERFORMANCE HIGH FORCE HYDRAULICS

Page  
**ENS...48-49**  
Hydraulic Nut Splitters



Page  
**HNS...50**  
Hydraulic Nut Splitters



Page  
**HS...51**  
Hydraulic Spreaders



Page  
**FLS15...52-53**  
Hydraulic Flange Spreader



Page  
**HFS...54**  
Pipe Flange Spreader



Page  
**EHN...55**  
Hydraulic Nut



## NUT SPLITTERS

### HYDRAULIC - ENS

3/4" to 3-1/2" bolt diameter  
M20 to M90



**ENS**  
Single Acting



**SUBSEA  
VERSION**  
Double Acting

Double acting (subsea) version comes standard with 700 bar, 1/4" NPT, Flat Face (FF) couplers. To use with top side pumps, change out couplers to 700 bar, 1/4" NPT, Screw-to-connect style. See page 100 for coupler details.

#### OK FOR SUBSEA



## ENS HYDRAULIC NUT SPLITTER

Our hydraulic nut splitter offers a reliable and effective solution to the removal of seized and corroded nuts.

- Triple edge replaceable cutting blade
- Blade positioning scale to eliminate bolt damage
- Cutting depth fixed - Nut size adjustable via rotating cylinder!
- Size range from 3/4" to 3-1/2" bolt diameters
- Designed to fit ANSI, ASME B.16.5 flanges
  - Will work with some API flanges – contact factory for details
- Twin line hydraulic version available for subsea use
- Versatile, reliable and trouble-free operations
- Operates off a standard 10,000 psi (700 bar) pump unit
- Built-in safety relief valve to protect tool & operator

### Accessory Ordering Information

Order No.	Description
<b>ENSBL010001</b>	Cutting blade for ENS1
<b>ENSBL020001</b>	Cutting blade for ENS2
<b>ENSBL030001</b>	Cutting blade for ENS3
<b>ENSBL040001</b>	Cutting blade for ENS4



## Specifications and Dimensional Data

Pick One Cylinder + One Head

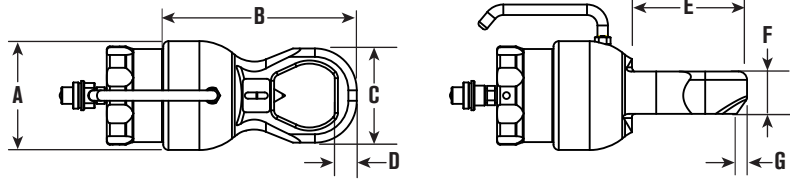

### Order Numbers

STANDARD	OPTIONAL	Head	Bolt Dia.		Nut A/F		A		B		C		D		E		F		G		Wt		
			Imperial	in	Metric	mm	mm	in	mm	in	mm	in	mm	in	mm	in	mm	in	mm	in	kg	lb	
ENSAS010001	ENSAS010004	ENSAS010002	3/4"	1-1/4	M20	30	104	4.1	228	9.0	76	3.0	18	0.7	104	4.1	40.5	1.6	9	0.4	6.7	14.8	
			7/8"	1-7/16	M22	32																	
			1"	1-3/8	M24	36																	
				M27	41																		
		ENSAS010003	3/4"	1-1/4	M20	30																	
			7/8"	1-7/16	M22	32																	
	1"		1-3/8	M24	36																		
	1-1/8"		1-13/16	M27	41																		
	1-1/4"		2	M30	46																		
			M33	50																			
	ENSAS020001	ENSAS020004	ENSAS020002	1-1/8"	1-13/16	M30	46	138	5.4	305	12.0	102	4.0	22	0.9	132	5.2	57.5	2.3	6	0.2	15.8	34.8
				1-1/4"	2	M33	50																
1-3/8"				2-3/16	M36	55																	
1-1/2"				2-3/8	M39	60																	
ENSAS020003			1-1/8"	1-13/16	M30	46																	
			1-1/4"	2	M33	50																	
		1-3/8"	2-3/16	M36	55																		
		1-1/2"	2-3/8	M39	60																		
			M42	65																			
			M45	70																			
ENSAS030001		ENSAS030006	ENSAS030002	1-3/4"	2-3/4	M45	70	190	7.5	406	16.0	132	5.2	28	1.1	189	7.4	80.5	3.2	8	0.3	42	92.6
				1-7/8"	2-15/16	M48	75																
	2"			2-1/8	M52	80																	
	ENSAS030003		1-3/4"	2-3/4	M45	70																	
			1-7/8"	2-15/16	M48	75																	
			2"	2-1/8	M52	80																	
			M56	85																			
	ENSAS030004	1-3/4"	2-3/4	M45	70																		
		1-7/8"	2-15/16	M48	75																		
		2"	2-1/8	M52	80																		
		2-1/4"	3-1/2	M56	85																		
		2-1/2"	3-7/8	M60	90																		
				M64	95																		
	ENSAS030005	1-3/4"	2-3/4	M45	70																		
		1-7/8"	2-15/16	M48	75																		
		2"	2-1/8	M52	80																		
		2-1/4"	3-1/2	M56	85																		
		2-1/2"	3-7/8	M60	90																		
2-3/4"		4-1/4	M64	95																			
			M68	100																			
			M72	105																			
ENSAS040001	ENSAS040004	ENSAS040002	2-3/4"	4-1/4	M76	110	235	9.3	474	18.7	189	7.4	36.5	1.4	235	9.3	110.5	4.4	4	0.2	73	160.9	
			3"	4-5/8	M80	115																	
		ENSAS040003	2-3/4"	4-1/4	M76	110																	
	3"		4-5/8	M80	115																		
	3-1/4"		5	M85	120																		
			M90	130																			

Order a cylinder and a head to make complete nut splitter. Cylinders are interchangeable with heads within specific size ranges. Each are sold separately.

# NUT SPLITTERS

## HYDRAULIC - HNS

15 & 25 Ton Capacity  
700 bar/10,000 psi



**HNS150**



**HNS150A**



**HNS225**

## HNS HYDRAULIC NUT SPLITTER

- “Dial-in” feature on HNS150 makes adjustment of splitter simple, without the worry of damaging the bolt
- Specially designed “tool steel” cutter blade penetrates the nut to the precise point where it cracks, stopping short of the bolt threads
- Nut splitter features a dramatically improved cutter blade with an 800% greater resistance to chipping and breaking over previous models
- All models feature a rugged one-piece cutting frame coupled to a heavy-duty hydraulic cylinder
- Compact size allows you to use it in confined areas where it will deliver enough force to split the toughest “fused” or rusted-on grade 2H nuts
- Simply split nut on one side, spin nut splitter 1/2 turn and make second cut on opposite side; nut separates into halves for easy removal
- Uses a standard 3/8" high flow coupler



Align mark on cutter blade with scale.

### Specifications and Dimensional Data

#### HNS150A

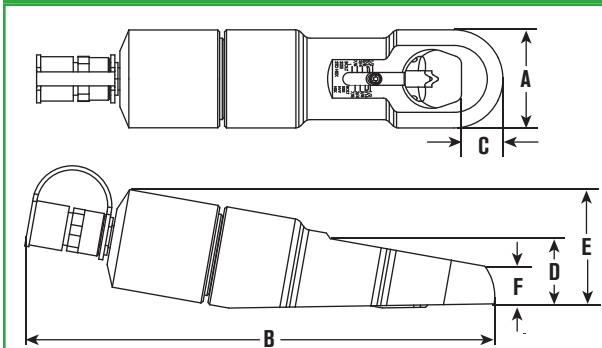

#### HNS150 & HNS225

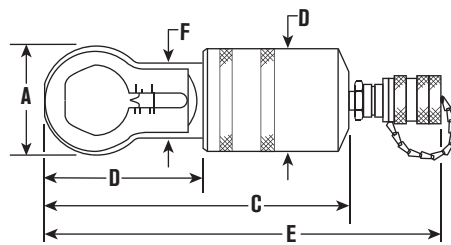

Tool Model	A	B	C	D	E	F	HEAD THICKNESS	REPLACEMENT BLADE	TOOL Wt
HNS150	2.875	3.375	7.875	2.75	10.375	2.0625	1	308840	8.1
HNS150A	3.02	14.2	1.03	2.11	3.7	1.16	1	351985	15.8
HNS225	4.25	6	14.375	3.875	N/A	3.25	1.5	308022	29

Order No.	CAPACITIES (by Nut Grade)			
	2 or A in. hex	5 or B in. hex	8 or C in. hex	2H in. hex
HNS150	1/2 - 1-1/2	1/2 - 1-1/2	1/2 - 1-5/16	1/2 - 1-1/8
HNS150A	1/2 - 1-1/2	1/2 - 1-1/2	1/2 - 1-5/16	1/2 - 1-1/8
HNS225	1-1/8 - 2-1/4	1-1/8 - 2-1/4	1-1/8 - 2-1/4	1-1/8 - 1-11/16

## HS HYDRAULIC SPREADERS

- Often used to position and align heavy pipes and flanges for easier bolting.
- Conforms to ASME B30.1 standard.
- High strength alloy steel forged upper and lower jaws on HS2000.
- Jaws are spring-return; retract automatically when pressure is released.
- Uses a standard 3/8" high flow coupler

## HYDRAULIC SPREADERS

HS

1-1/2 Short Tons  
700 bar / 10,000 psi



**HS2000**  
(Forged Steel)



**HS3000**  
(High Grade Ductile Iron)

### Specifications and Dimensional Data

#### HS2000 SPECIFICATIONS

**Maximum Rated Capacity:** 0.91 metric tons @ 690 bar (1 short ton @ 10,000 psi)

**Maximum Spread:** 101 mm (4")

**Minimum Clearance Required:** 14.3 mm (9/16")

**Oil Required:** 10.3 mL (0.63 in<sup>3</sup>)

#### HS3000 SPECIFICATIONS

**Maximum Rated Capacity:** 1.36 metric tons @ 690 bar (1-1/2 short ton @ 10,000 psi)

**Maximum Spread:** 292 mm (11-1/2")

**Minimum Clearance Required:** 31.8 mm (1-1/4")

**Oil Required:** 57.4 mL (3.50 in<sup>3</sup>)

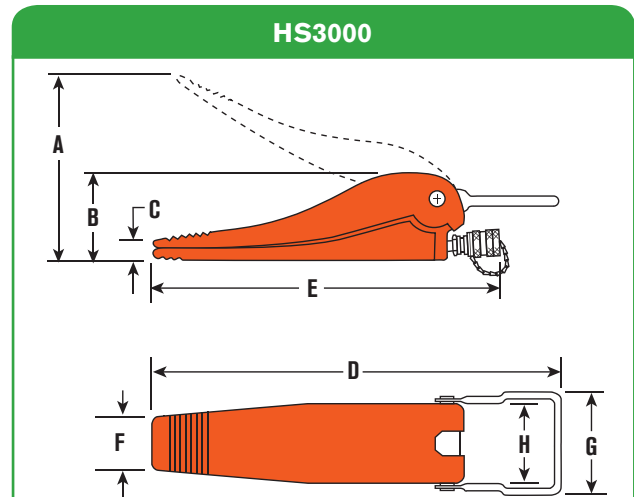
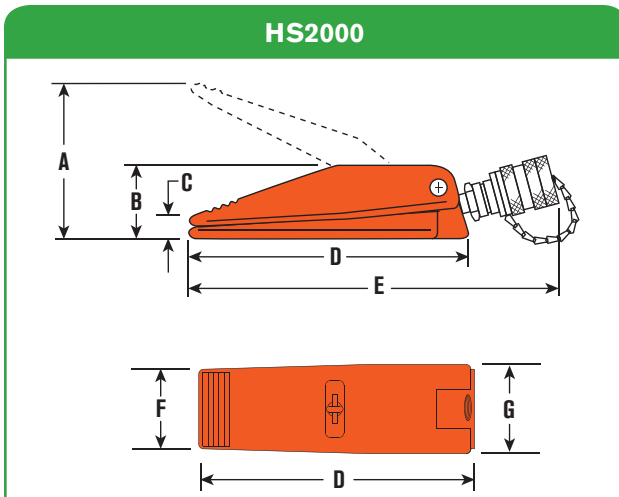

Order Number	Capacity metric ton (short ton)	A	B	C	D	E	F	G	H	Oil Capacity mL (cu in)	Min. Clearance Required mm (in)	Wt kg (lb)
		mm (in)	mm (in)	mm (in)	mm (in)	mm (in)	mm (in)	mm (in)	mm (in)			
HS2000	0.91 (1)	101 (4)	50.8 (2)	14.3 (9/16)	176 (6-15/16)	236.5 (9-5/16)	50.8 (2)	57.1 (2-1/4)	-	10.3 (0.63)	14.3 (9/16)	2.2 (4.8)
HS3000	1.36 (1-1/2)	292 (11-1/2)	108 (4-1/4)	30.2 (1-3/16)	511 (20-1/8)	450.9 (17-3/4)	57.1 (2-1/4)	142.9 (5-5/8)	92 (3-5/8)	57.4 (3.5)	31.8 (1-1/4)	10 (22)

Value(s) shown in short tons (2,000 lb). To convert to long tons, multiply by 0.893. To convert to metric tons, multiply by 0.907

# HYDRAULIC SPREADER

## FLS15

15 Metric Ton Capacity  
700 bar/10,000 psi



**FLS15 VERSION**  
With Serrated shoes—Wedge Fully Opened



**FLS15-ST VERSION**  
With Stepped Shoes—Wedge Closed

## FLS15 HYDRAULIC SPREADER

SPX Bolting Systems is pleased to introduce the FLS15 hydraulic spreader. This unit is ideal for pipe and flange repair. It can also be used for removing elbows, gasket and metal seal replacement on couplers, heavy equipment maintenance, and many other tasks. The spreader is capable of developing up to 15 metric tons of force, is lightweight, and easy to use due to its ergonomic design.

- 33,000 pound (15 metric ton) wedge-driven spreader
- Jaws fully supported by wedge for excellent durability
- Low friction provided by heavy-duty extended-life lubricant
- Ideal for flanges with narrow gaps - only .2 inches (5 mm) required for entry
- Very high strength due to special alloy used
- Compact and lightweight design - only 9.9 inches (252 mm) long at a weight of 7 pounds (3.2 kg)
- Easy to use - ergonomically balanced handle (optional)
- Suitable for the offshore environment due to superior corrosion resistance
- Quick adjustments for various tasks due to interchangeable shoes (both stepped and serrated)
- Easy and quick maintenance - Only T40 Torx tool required
- Includes female half coupler - mates to standard 3/8" male half coupler (No. 9798).
- Both serrated- and stepped-shoe versions available



## FLS15 HYDRAULIC SPREADER

This hydraulic spreader operates using the integrated wedge concept. It is ideal for creating space for flange surface cleaning and repair, and for gasket replacement. The spreader is single-acting, and should be used with a hydraulic pump capable of holding pressure. Maximum operating pressure is 10,000 psi (700 bar).

### Spreading Force:

Maximum 33,000 lb (15 metric tons) per tool at 10,000 psi (700 bar). It is recommended that the tools be used in pairs, providing a maximum combined force of 66,000 lb (30 metric tons).

### Typical Applications:

- Pipe and flange repair
- Removing elbows
- Couplers - gasket and metal seal replacement
- Heavy equipment maintenance

## Specifications and Dimensional Data

### FLS15 Spreader

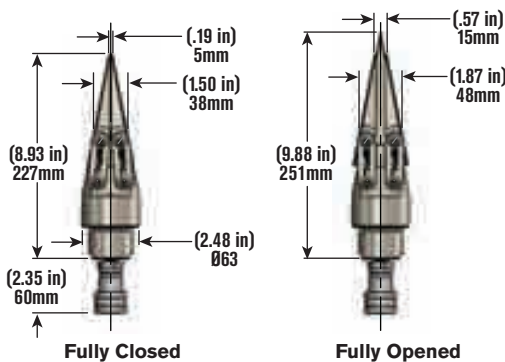

### FLS15-ST Spreader

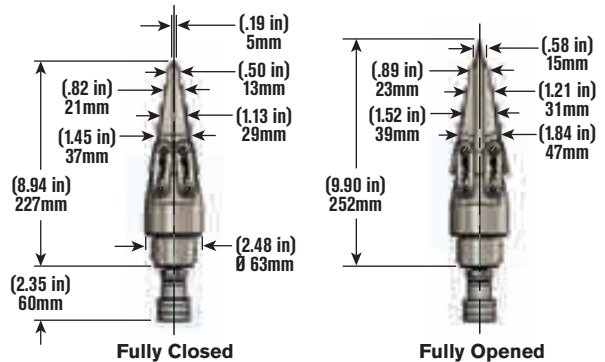

Order No.	Maximum Spreading Force	Minimum Tip Clearance	Maximum Tip Spread	Spreader Type	Oil Capacity	Weight	Maximum Operating Pressure
FLS15 or FLS15-ST	33,000 Pounds (15 Metric Tons)	.197 Inches (5 mm)	.59 Inches (15 mm)	Hydraulic	1 Cubic Inch (16 cc)	7 Pounds (3.2 kg)	10,000 psi (700 bar)

## Available FLS15 Accessories



Handle  
Part Number 2008410



Stepped Shoe  
Part Number 2008083\*



Serrated Shoe  
Part Number 2008082\*



Stepped Block  
Part Number SB15

## Recommended Components

Description	Part Number (Americas & Asia)	Part Number (Europe)
Two Speed, Single-Acting Hand Pump	P19L	P19L
Hydraulic Hose Assembly	9764	9764E
Pressure Gauge	9040 (Primary Units = psi)	9040E (Primary Units = bar)
Gauge Adapter	9670	9670
Coupler (male half coupler)	9798	9798
2 Station Manifold with Needle Valves	9642	9642
Female Half Coupler	9796	9796
Male Connector, 3/8	9682	9682

# PIPE FLANGE HYDRAULIC SPREADER - HFS

5 & 10 Ton Capacity  
700 bar/10,000 psi



HFS3A

## HFS PIPE FLANGE SPREADER

- You'll never again have to resort to "hammer and chisel" methods that waste time and effort. Flange spreaders should be used in pairs to provide even spreading force.
- Standard 60° wedge is suitable for most flanges; 30° "thin" and 60° "blunt" wedges are optional.
- The HFS3A is designed for applications where total thickness of flanges and max. spread gap is 3" or less and flange bolts are a min. of 11/16" dia.
- Use HFS6A if total thickness of flanges and max. spread gap is 6" or less, and flange bolts are a min. of 13/16" dia.
- Max working pressure 700 bar (10,000 psi)
- Uses a standard 3/8" high flow coupler

### Specifications and Dimensional Data

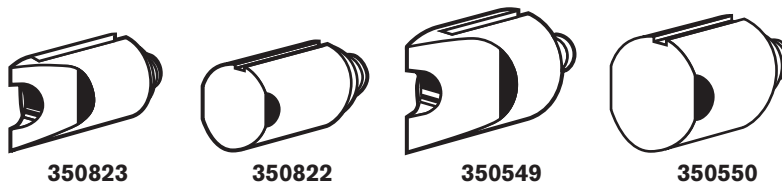

Order No.	Capacity Metric tons Short tons	Standard Wedge Type	Optional Wedges		Min. Flange Opening			Max. Flange Opening			Combined Flange Opening mm in	Min. Pin Dia.	Wt lb kg
			30°	60°	60°	60°	30°	60°	60°	30°			
			Thin	Blunt	Std. Blunt		Std. Blunt						
HFS3A	4.5	60° Sharp	350823	350822	1,6	25,4	1,6	38,1	38,1	18,3	76,2	17,4	4,1
	5				1/16"	1"	1/16"	1-1/4"	1-1/4"	23/32"			
HFS6A	9	60° Sharp	350549	350550	1,6	38,1	1,6	50,8	50,8	24,6	152,4	20,6	8,2
	10				1/16"	1-1/2"	1/16"	2"	2"	31/32"			

Value(s) shown in short tons (2,000 lb). To convert to long tons, multiply by 0.893. To convert to metric tons, multiply by 0.907.

## EHN TOP COLLAR HYDRAULIC NUT

Our precision machined top collar hydraulic nuts offer a quick, accurate and cost effective solution to simultaneous tightening of multiple bolted joints.

In addition to standard features normally associated with hydraulic nuts, our system also provides the following benefits:

- Compact enough to fit the most confined spaces
- Maximum load generated at 1,500 bar (21,750 psi)
- Energized from either a hand operated or air driven pump
- Custom Hydraulic Nut designs available
- Alternative Bottom Collar and Shim type versions available
- Made to order. Contact factory for availability.

## HYDRAULIC NUT TOP COLLAR - EHN



### Specifications and Dimensional Data

Tool Ref.	THREAD		INITIAL LOAD		HYDRAULIC AREA		NUT DIAM. mm	HEIGHT mm	STROKE mm
	Metric	in	kN	Ton F	mm <sup>2</sup>	in <sup>2</sup>			
EHN1-TC	M20	3/4	180	18.07	1200	1.86	68	55	5
EHN2-TC	M22	7/8	180	18.07	1200	1.86	68	55	5
EHN3-TC	M24	1	195	19.57	1300	2.02	72	55	5
EHN4-TC	M27	1-1/8	210	21.08	1400	2.17	75	55	5
EHN5-TC	M33	1-1/4	250	25.09	1667	2.58	82	57	5
EHN6-TC	M36	1-3/8	300	30.11	2001	3.10	88	57	5
EHN7-TC	M39	1-1/2	340	34.12	2267	3.51	93	58	5
EHN8-TC	M42	1-5/8	400	40.15	2667	4.13	100	62	6
EHN9-TC	M45	1-3/4	460	46.17	3067	4.75	106	64	6
EHN10-TC	M48	1-7/8	500	50.18	3334	5.17	110	64	6
EHN11-TC	M52	2	560	56.20	3734	5.79	117	67	6
EHN12-TC	M56	2-1/4	720	72.26	4801	7.44	128	74	8
EHN13-TC	M64	2-1/2	900	90.33	6002	9.30	141	77	8
EHN14-TC	M68	2-3/4	1000	100.37	6668	10.34	150	78	8
EHN15-TC	M76	3	1200	120.44	8002	12.40	162	81	8
EHN16-TC	M80	3-1/4	1400	140.51	9336	14.47	174	87	10
EHN17-TC	M90	3-1/2	1600	160.59	10669	16.54	187	95	10
EHN18-TC	M95	3-3/4	1700	170.62	11336	17.57	194	102	10
EHN19-TC	M100	4	1900	190.70	12670	19.64	205	110	10
EHN20-TC	M110	4-1/2	2200	220.81	14671	22.74	223	120	10
EHN21-TC	M125	5	2400	240.88	16004	24.81	239	135	15
EHN22-TC	M140	5-1/2	2900	291.06	19338	29.97	261	145	15
EHN23-TC	M150	6	3400	341.24	22673	35.14	282	160	15

NOTE: EHN#-TC" is not a part number that can be ordered please contactcontact factory for ordering information.

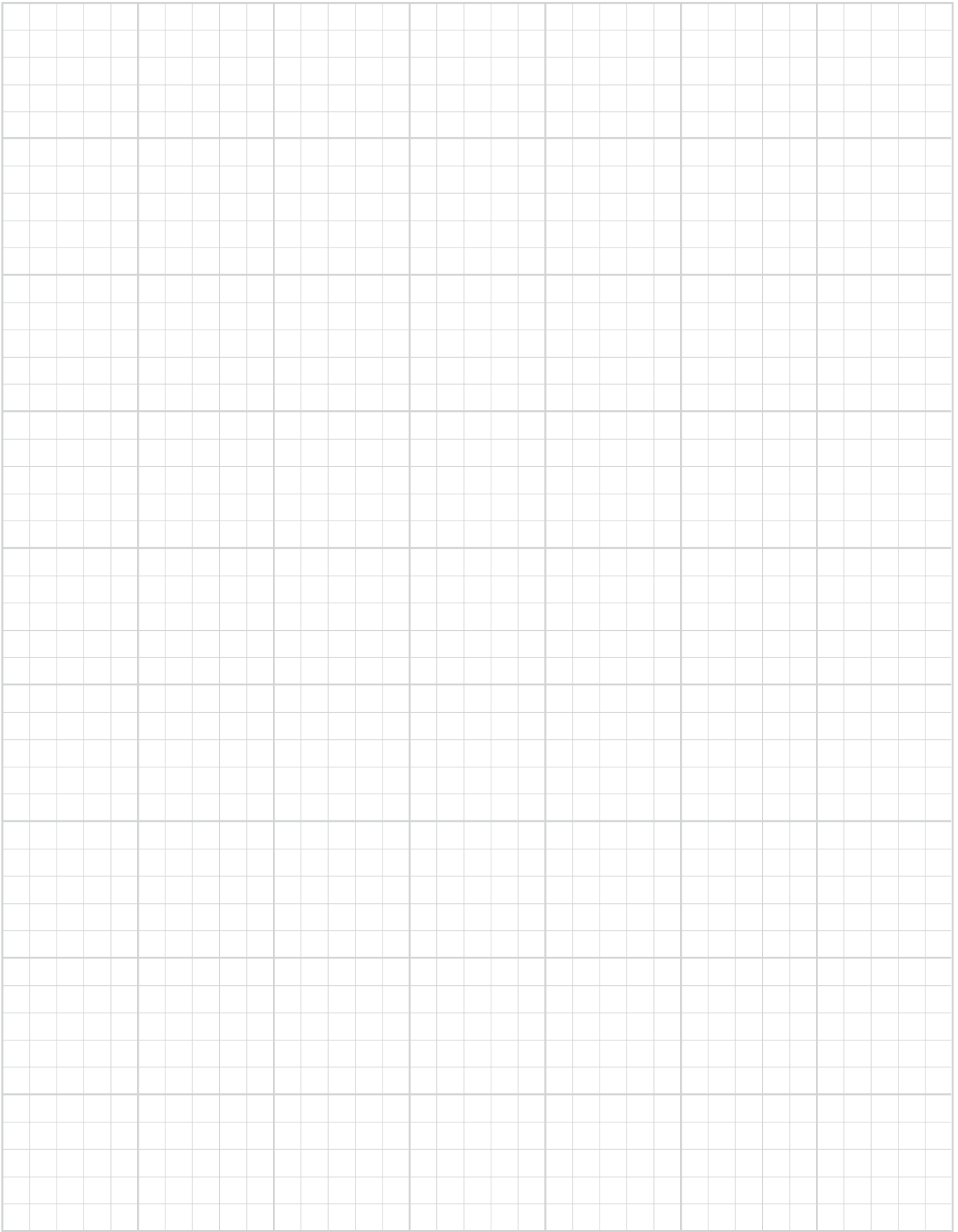



# SUBSEA TOOLS

**HIGH PERFORMANCE HIGH FORCE HYDRAULICS**

Page  
**SST...58-63**  
Subsea Stud Tensioner



Page  
**SFP...60-63**  
Subsea Flange Pullers



Page  
**SUBSEA  
ACCESSORIES...64-65**



## OTHER TOOLS FOR SUBSEA

Page  
**ENS...48-49**  
Hydraulic Nut Splitters



Page  
**TWHC...16-17**  
High Cycle Torque Wrench



Page  
**TWLC...26-29**  
Low Clearance Torque Wrench



**OK FOR SUBSEA**



## SUBSEA TENSIONER

### STUD TENSIONER - SST

Bolt coverage from 3/4" to 3-1/2"  
only 7 tools, SST1 to SST7



Patented Quick Reaction Nut

## SST STUD TENSIONER

### Quick Reaction Subsea Tensioner

Our Subsea bolt tensioner incorporating the quick reaction nut feature reduces diver fatigue, improving diver safety and productivity.

- Visible piston stroke indication
- Positive 'over-stroke' stop to prevent piston expulsion/ seal damage.
- Piston / cylinder misalignment compensation
- Anti-slip cylinder surface for improved handling
- Low friction seals
- Anti-corrosion coating
- Bolt coverage from 3/4" to 4" (M20 to M100)
- Designed to fit BS1560 / ANSI B16.5 / API flanges, as well as most compact flange designs

## Specifications and Dimensional Data

Tool Ref Load Cell Order No.	Stud Diameter				Tool Load		Hydraulic Area		Approx Wt.		Minimum Bolt Protrusion Above Nut			
	Imperial	Adapter Kit Order No.	Metric	Adapter Kit Order No.	Lbf	kN	in <sup>2</sup>	mm <sup>2</sup>	lb	kg	Imp bolts		met bolts	
											in	mm	in	mm
SST1 SSTAS010001	3/4"	QRNAS010001	M20	QRNAS010004	31,500	140	0.368	934	3.30	1.50	4.09	104	4.21	107
	7/8"	QRNAS010003	M22	QRNAS010005							3.98	101	4.13	105
SST2 SSTAS020001	1"	QRNAS020001	M24	QRNAS020004	53,900	240	0.630	1,600	6.16	2.80	5.24	133	5.47	139
	1-1/8"	QRNAS020003	M27	QRNAS020005							5.12	130	5.35	136
	-	-	M30	QRNAS020006							-	-	5.28	134
SST3 SSTAS030001	1-1/4"	QRNAS030003	M33	QRNAS030005	85,400	380	0.998	2,534	8.80	4	5.35	136	5.59	142
	1-3/8"	QRNAS030004	M36	QRNAS030006							5.24	133	5.47	139
SST4 SSTAS040001	1-1/2"	QRNAS040003	M39	QRNAS040005	123,700	550	1.444	3,668	13.20	6	5.51	140	5.79	147
	1-5/8"	QRNAS040004	M42	QRNAS040006							5.35	136	5.67	144
SST5 SSTAS050001	1-3/4"	QRNAS050001	M45	QRNAS050005	197,800	880	2.310	5,868	19.80	9	5.94	151	6.3	160
	1-7/8"	QRNAS050003	M48	QRNAS050006							5.83	148	6.22	158
	2"	QRNAS050004	M52	QRNAS050007							5.71	145	6.06	154
SST6 SSTAS060001	2-1/4"	QRNAS060001	M56	QRNAS060005	351,000	1,560	4.099	10,411	32.34	14.7	6.54	166	7.01	178
	2-1/2"	QRNAS060003	M60	QRNAS060006							6.30	160	6.89	175
	2-3/4"	QRNAS060004	M64	QRNAS060007							6.06	154	6.77	172
	-	-	M68	QRNAS060008							-	-	6.65	169
	-	-	M70	QRNAS060009							-	-	6.5	165
SST7 SSTAS070001	3"	QRNAS070001	M76	QRNAS070005	579,000	2,575	6.762	17,176	55	25	7.13	181	7.68	195
	3-1/4"	QRNAS070003	M80	QRNAS070006							6.89	175	7.56	192
	3-1/2"	QRNAS070004	M85	QRNAS070007							6.65	169	7.40	188
	-	-	M90	QRNAS070008							-	-	7.24	184
SST8 SSTAS080001	3-3/4"	QRNAS080001	M95	QRNAS080004	775,300	3,447	9.054	22,997	86.02	39.1	8.07	205	8.82	224
	4"	QRNAS080003	M100	QRNAS080005							7.83	199	8.66	220

In order to form a complete tensioner, order a load cell (SSTAS0#0001) and an adapter kit (QRNAS0#00##).

## Specifications and Dimensional Data

**Piston stroke:** 30mm except for SST1 - 20mm

**Max tool pressure:** 21,750 psi (1,500 bar)

**Bolt protrusion above nut:** refer to chart below for stud protrusion requirements

'D' includes an allowance for tool removal after bolt tightening with 30mm tool stroke

Product development is constantly taking place and dimensions may change without notice

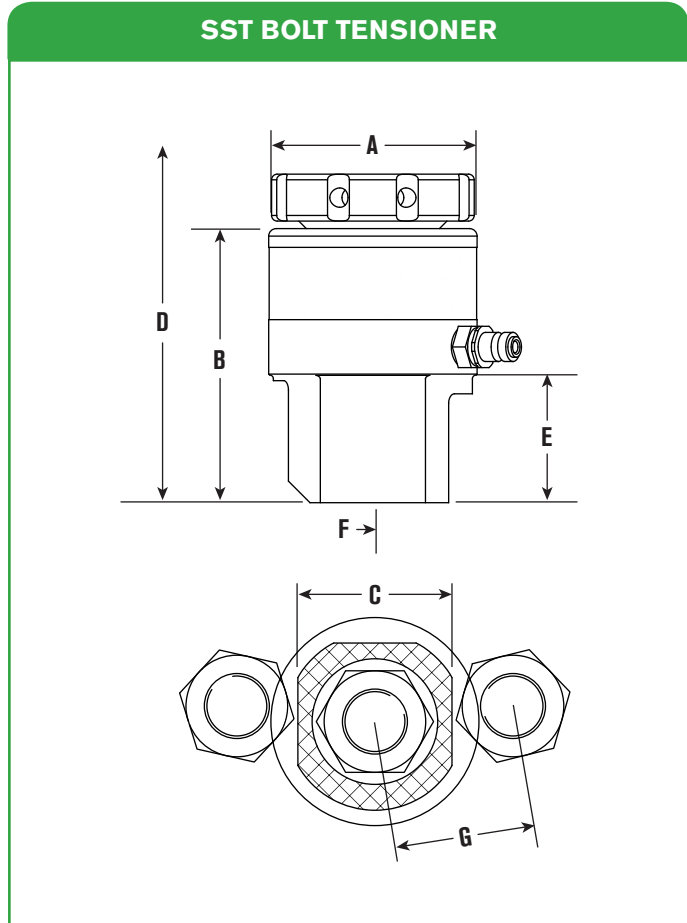

A		B		C		D		E		F		G				Stud Diameter		Tool Ref Load Cell Order No.		
in	mm	in	mm	in	mm	Imp bolts in	met bolts mm	in	mm	in	mm	Imp bolts in	met bolts mm	Imp	Metric					
2.6	66	3.8	97	1.9	48	9	228	9	228	1.6	40	0.7	19	1.7	44	1.7	44		3/4"	M20
						1.8	46	1.8	45					7/8"	M22	SSTAS010001				
3.2	82	5	127.5	2.4	60	11.7	296	11.7	296	2.2	56.5	1	24.5	2.2	55	2.1	54	1"	M24	SST2
														2.3	58	2.2	56	1-1/8"	M27	SSTAS020001
														-	-	2.3	58	-	M30	
														2.7	69	2.7	68	1-1/4"	M33	SST3
3.8	97	5.4	137	3	77	12.2	309	12.2	309	2.5	63	1.1	28	2.8	72	2.8	71	1-3/8"	M36	SSTAS030001
														3.2	81	3.2	81	1-1/2"	M39	SST4
4.4	111	5.7	146	3.5	90	12.7	322	12.7	322	2.7	68	1.3	33.5	3.3	84	3.3	84	1-5/8"	M42	SSTAS040001
														3.9	98	3.9	98	1-3/4"	M45	SST5
5.4	136	6.2	158	4.5	114	13.5	342	13.5	342	3.1	77.5	1.6	40	4	101	4	101	1-7/8"	M48	SSTAS050001
														4.1	104	4.1	104	2"	M52	
														4.8	122	4.7	120	2-1/4"	M56	
7	177	7.1	180.5	5.5	140	14.7	374	14.7	374	3.8	97	2.1	53	5	128	4.8	123	2-1/2"	M60	SST6
														5.2	133	5	126	2-3/4"	M64	SSTAS060001
														-	-	5.1	129	-	M68	
														-	-	5.2	132	-	M70	
														6.3	159	6.1	155	3"	M76	
8.5	217	8	202	7.1	180	16.1	409	16.1	409	4.6	117.5	3.5	88	6.5	164	6.2	157	3-1/4"	M80	SST7
														6.7	170	6.3	160	3-1/2"	M85	SSTAS070001
														-	-	6.5	166	-	M90	
														7.5	190	7.2	184	3-3/4"	M95	SST8
9.8	248	9.1	230	8.3	210	18.9	480	18.9	480	5	128	3.3	85	7.7	196	7.5	190	4"	M100	SSTAS080001

## FLANGE PULLERS

SUBSEA - SFP

700 bar/10,000 psi

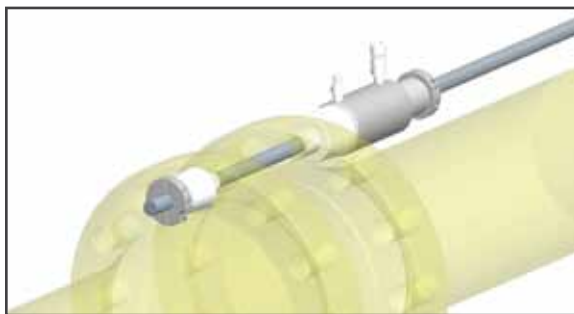
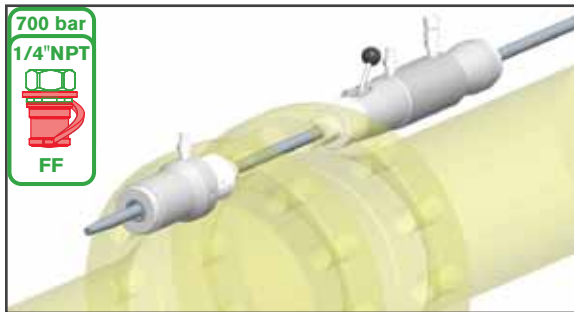

## WIRE ROPE FLANGE PULLING SYSTEM

- Compact design
- Long Piston Stroke - 102mm (4")
- Self activating collet design
- Auto grab Anchor Collet with hydraulic release
- Manually releaseable Retract Collet prevents lock on
- High strength, low rotation wire rope
- Anti-Slip surfaces
- Operated via separate diver control valve providing precise control for up to 4 pullers

## THREADED BAR FLANGE PULLING SYSTEM

- Compact design
- Long Piston Stroke - 102mm (4")
- 700 bar (10,000 psi) systems
- Rapid assembly using Quick Release Reaction Nuts
- High strength threaded bar
- Anti-Slip surfaces
- Operated via separate diver control valve providing precise control for up to 4 pullers

### FEATURES

#### Compact Design

Designed to fit ANSI B16.5, MSS SP44, API 6A and most other flange applications dedicated flange hole adaptors.

#### Hydraulic Anchor Collet Release

Anchor collet automatically grips wire rope (without hydraulic pressure). Collets can be fully released by applying hydraulic pressure.

#### Auto Advance Collet Release

Advance collet fully disengages when the pulling cylinder is fully retracted

#### Manual Retract Collet Release

Retract collet can be manually disengaged, allowing the pulling cylinder (including Advance and Retrace collets) to be removed from the wire rope while the rope is installed in the flanges. Also allows the pulling system to be removed when pipe spring is evident (pipe spring makes the Anchor collet difficult to release).

#### Low Rotation Wire Rope

Special high load, 19mm and 22mm low rotation, steel wire rope ensure effective collet grip and reduces bird caging effects and strand unwinding.

#### Remote Diver Control Valve

Pulling Cylinders are controlled via a separate Valve Control Console allowing the diver to control the pullers remote from the work site. This eliminates bulky cylinder mounted control valves and negates constant diver intervention between pullers when advancing and retracting the cylinders.

#### Drawbar System Conversion with Quick Release Nuts

Pulling Cylinders can be simply converted to use a 1-1/8" threaded drawbar instead of wire ropes. The system utilizes Quick Release Reaction nuts for speed and versatility.

#### Flexible Design

Two or more cylinders can be linked together to cater for larger flange sizes/loads.

## Specifications and Dimensional Data

**Max capacity of cylinder:** 20.0 tonf (199.3 kN)

**Max operating pressure of cylinder:** 10,000 psi (700 bar)

**Max stroke of cylinder:** 4.0" (102 mm)

**Diameter of wire ropes / drawbar available:** 19.0mm, 22.0mm, 1-1/8" 8UN Drawbar

**Specified minimum breaking load of rope:** 19.0mm - 307 kN (30.8 tonf), 22mm - 415 kN (41.6 tonf)

**System operating pressure with 19.0 / 22.0 mm rope:** 5,000 psi (345 bar)

**System operating pressure with 1-1/8" drawbar (Gr B7):** 10,000 psi (690 bar)

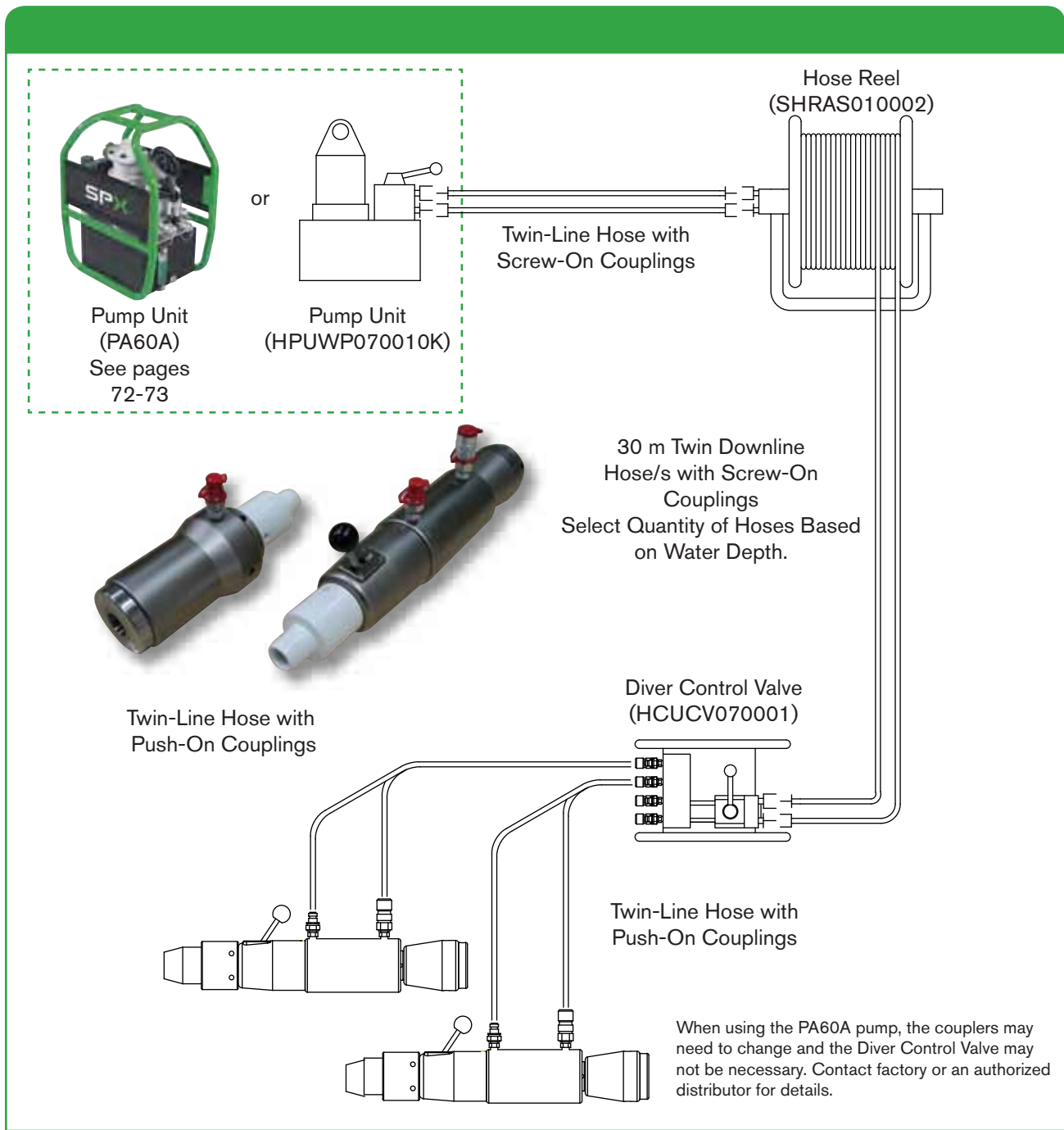

# FLANGE PULLERS SUBSEA - SFP

# WIRE ROPE FLANGE PULLING SYSTEM

## Specifications and Dimensional Data

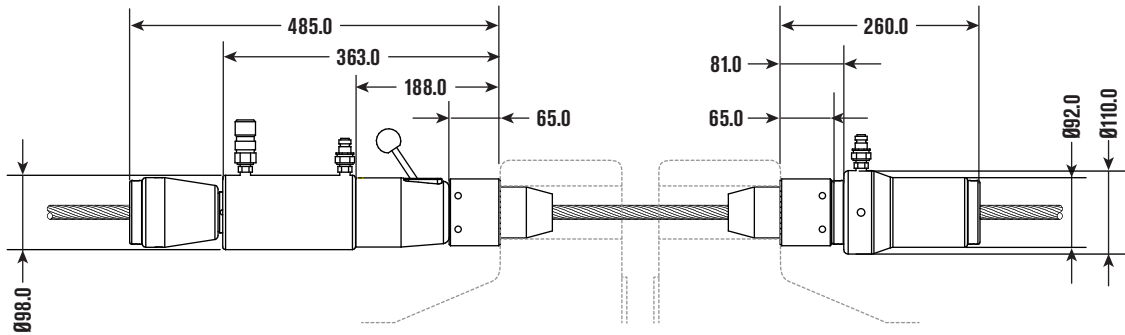
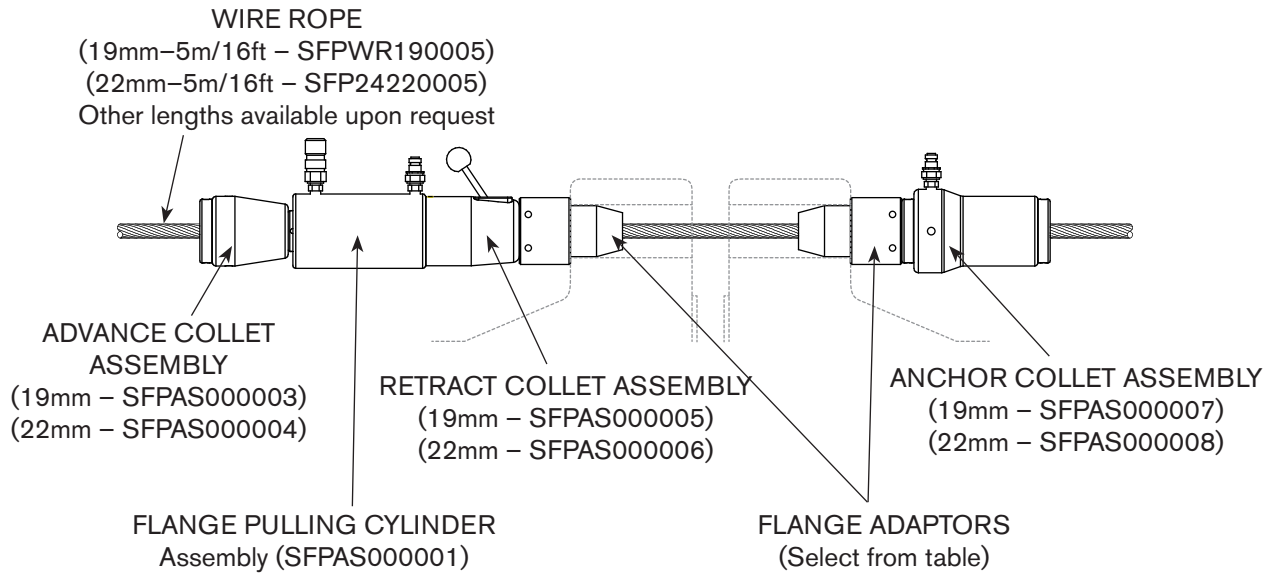

For Bolt Diameter		For Flange Hole Diameter		Wire Rope Flange Adapter Order No.
in	mm	in	mm	
3/4	M20	7/8	22.2	SFPWA000C00
7/8	M24	1	25.4	SFPWA000D00
1	M27	1-1/8	28.6	SFPWA000E00
1-1/8	M30	1-1/4	31.8	SFPWA000F00
1-1/4	M33	1-3/8	34.9	SFPWA000G00
1-3/8	M36	1-1/2	38.1	SFPWA000H00
1-1/2	M39	1-5/8	41.3	SFPWA000I00
1-5/8	M42	1-3/4	44.5	SFPWA000J00
1-3/4	M45	1-7/8	47.6	SFPWA000K00
1-7/8	M48	2	50.8	SFPWA000L00
2	M52	2-1/8	54	SFPWA000M00
2-1/4	M56	2-3/8	60.3	SFPWA000N00
2-1/2	M64	2-5/8	66.7	SFPWA000P00
2-3/4	M68/M70	2-7/8	73	SFPWA000Q00
3	M76	3-1/8	79.4	SFPWA000R00
3-1/4	M82	3-3/8	85.7	SFPWA000S00
3-1/2	M90	3-5/8	92.1	SFPWA000T00
3-3/4	M95	3-7/8	98.4	SFPWA000U00
4	M100	4-1/8	104.8	SFPWA000V00

# THREADED BAR FLANGE PULLING SYSTEM

## Specifications and Dimensional Data

1-1.8" 8UN THREADED DRAWBAR  
(2m/6.5ft – STDFA000167)  
Other lengths available upon request

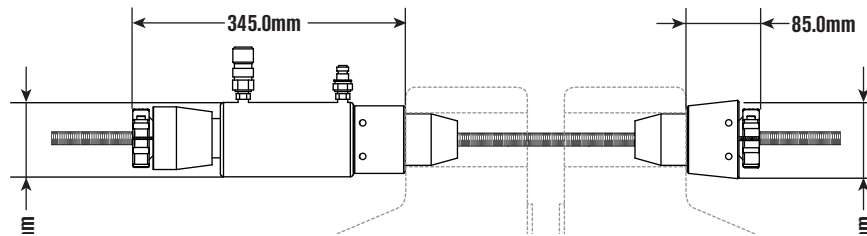
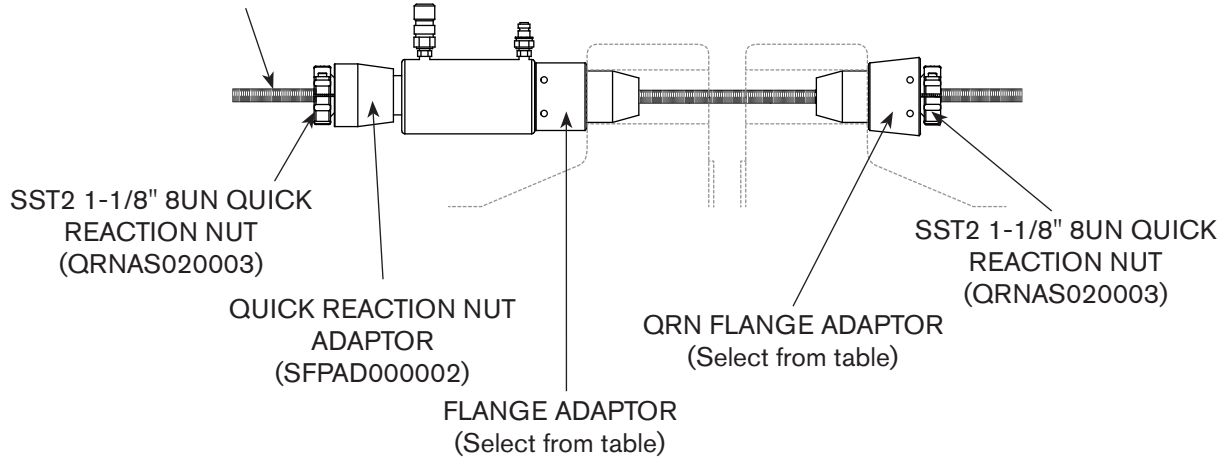

1-1.8" 8UN THREADED DRAWBAR  
(2m/6.5ft – STDFA000167)  
Other lengths available upon request

### Slave Bar Assembly

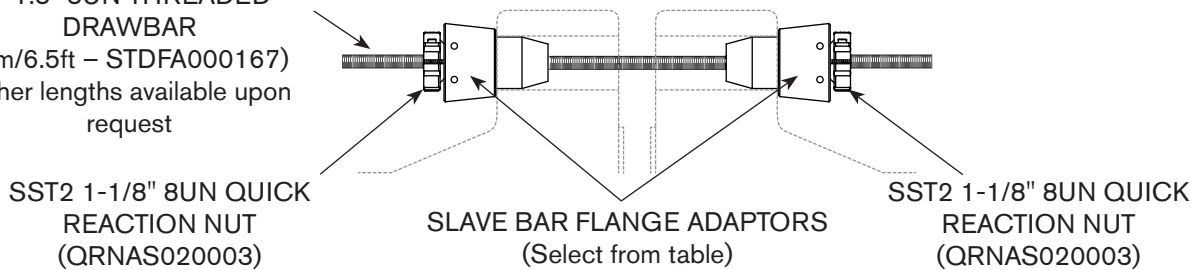

For Bolt Diameter		For Flange Hole Diameter		Threaded Drawbar Flange Adapter		
in	mm	in	mm	Flange Adapter	QRN Flange Adapter	Slave Bar Flange Adapter
1-1/4	M33	1-3/8	34.9	SFPTA000H00	SFPQA000H00	SFPSA000H00
1-3/8	M36	1-1/2	38.1			
1-1/2	M39	1-5/8	41.3	SFPTA000I00	SFPQA000I00	SFPSA000K00
1-5/8	M42	1-3/4	44.5	SFPTA000J00	SFPQA000J00	
1-3/4	M45	1-7/8	47.6	SFPTA000K00	SFPQA000K00	SFPSA000M00
1-7/8	M48	2	50.8	SFPTA000L00	SFPQA000L00	
2	M52	2-1/8	54	SFPTA000M00	SFPQA000M00	SFPSA000Q00
2-1/4	M56	2-3/8	60.3	SFPTA000N00	SFPQA000N00	
2-1/2	M64	2-5/8	66.7	SFPTA000P00	SFPQA000P00	SFPSA000Q00
2-3/4	M68/M70	2-7/8	73	SFPTA000Q00	SFPQA000Q00	
3	M76	3-1/8	79.4	SFPTA000R00	SFPQA000R00	SFPSA000T00
3-1/4	M82	3-3/8	85.7	SFPTA000S00	SFPQA000S00	
3-1/2	M90	3-5/8	92.1	SFPTA000T00	SFPQA000T00	SFPSA000V00
3-3/4	M95	3-7/8	98.4	SFPTA000U00	SFPQA000U00	
4	M100	4-1/8	104.8	SFPTA000V00	SFPQA000V00	

## HIGH FLOW PUMP

**Typical use: Flange Pullers, Torque Wrenches, Nutsplitters**

- Self priming, 2-speed operation
- 2.24 kw (3 hp) Air motor (50 CFM)
- 700 bar (10,000 psi) maximum pressure
- Calibratable 100mm (4") pressure gauge
- Adjustable pressure relief valve
- Flow rate up to 11.8 litres/min (720 cu. in/min)
- Internal oil cooler
- Low noise operation
- Pneumatic Filter / Regulator / Lubricator
- 9.5 Litre (2 gal.) reservoir (optional oil level gauge)
- Carrying frame (WxLxH): 430 x 460 x 460 (mm)
- Weight: 40 Kg (88 lb) (inc. oil)
- Alternate Pump: PA60A can be used as an alternate to the HPUWP070010K shown. See page 72 for details.

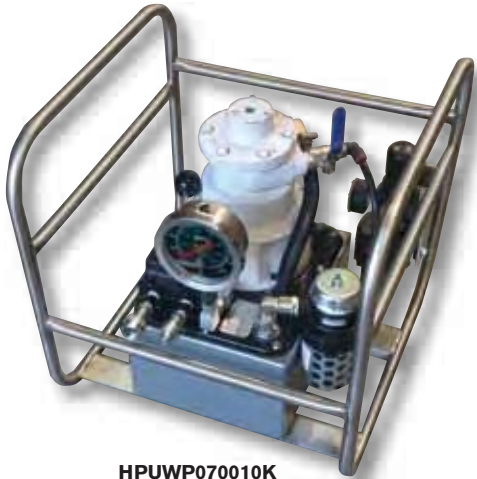

HPUWP070010K

## SINGLE & TWIN-LINE HOSE REELS

- Hose reels available for tension and torque applications
- -30°C to 80°C working temperature range
- Female quick connect couplings as standard
- Hose Reel Dimensions (WxLxH): 750 x 1,000 x 1,050 (mm), 29" x 39" x 41"
- Hose Reel Weight: 65 Kg (145 lb) (without hose)

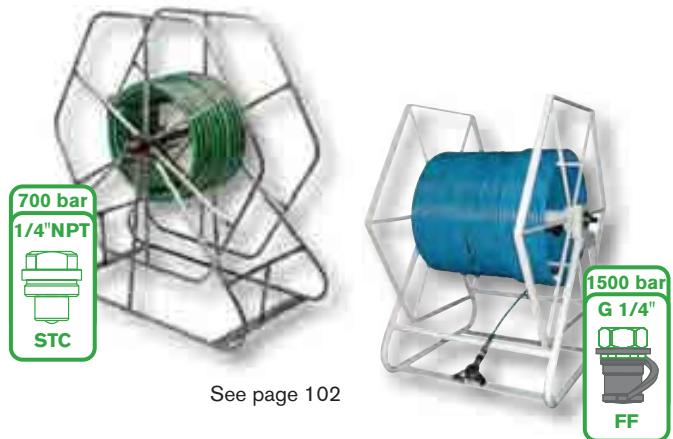

See page 102

## REMOTE DIVER CONTROL VALVE

**Gives diver precise control of Flange Pullers, Torque Wrenches, Nutsplitters, Jack, Cylinders, etc.**

- 700 bar (10,000 psi) maximum working pressure
- Allows connection of up to 4 tools
- Stainless steel construction (rust free)
- Internal relief valve controls retract pressure
- Couplers on reel side are flat face for easy connection under water. Couplers on valve side match the required tool.
- Dimensions (WxLxH): 420 x 270 x 200 (mm)
- Weight: 9 kg (19.8 lb)

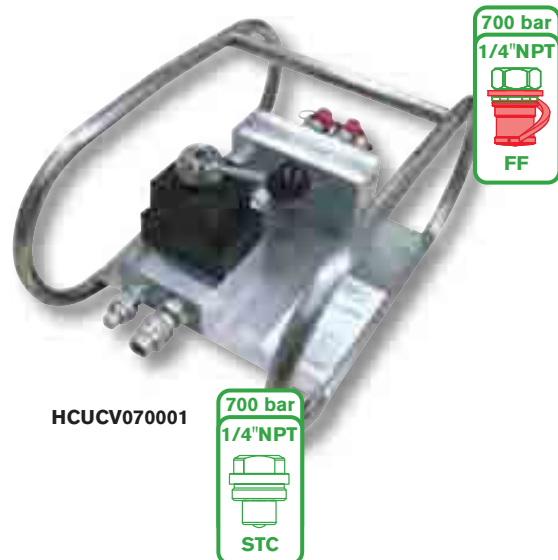

HCUCV070001





**HPOTP150002K**  
See pages 92-95

## HIGH FLOW BOLT-TENSIONING PUMP

### Typical use: Subsea Bolt Tensioners, Segmented Tensioners

- 1,500 bar (21,750 psi) maximum working pressure (restricted)
- Calibrated 150mm (6") pressure gauge
- Flow rate up to 1.14 litres/min (70 cu. in/min)
- Dual oil outlets with quick-connect no spill couplings
- Pneumatic Filter / Regulator / Lubricator
- 9.5 Litre (2 gal.) polyethylene reservoir
- Dimensions (WxLxH): 465 x 530 x 515 (mm), 18" x 20" x 20"
- Approx. Weight: 23 Kg (51 lb)

### OFFSHORE PUMP & HOSE ARRANGEMENT FOR SST SUBSEA TENSIONERS

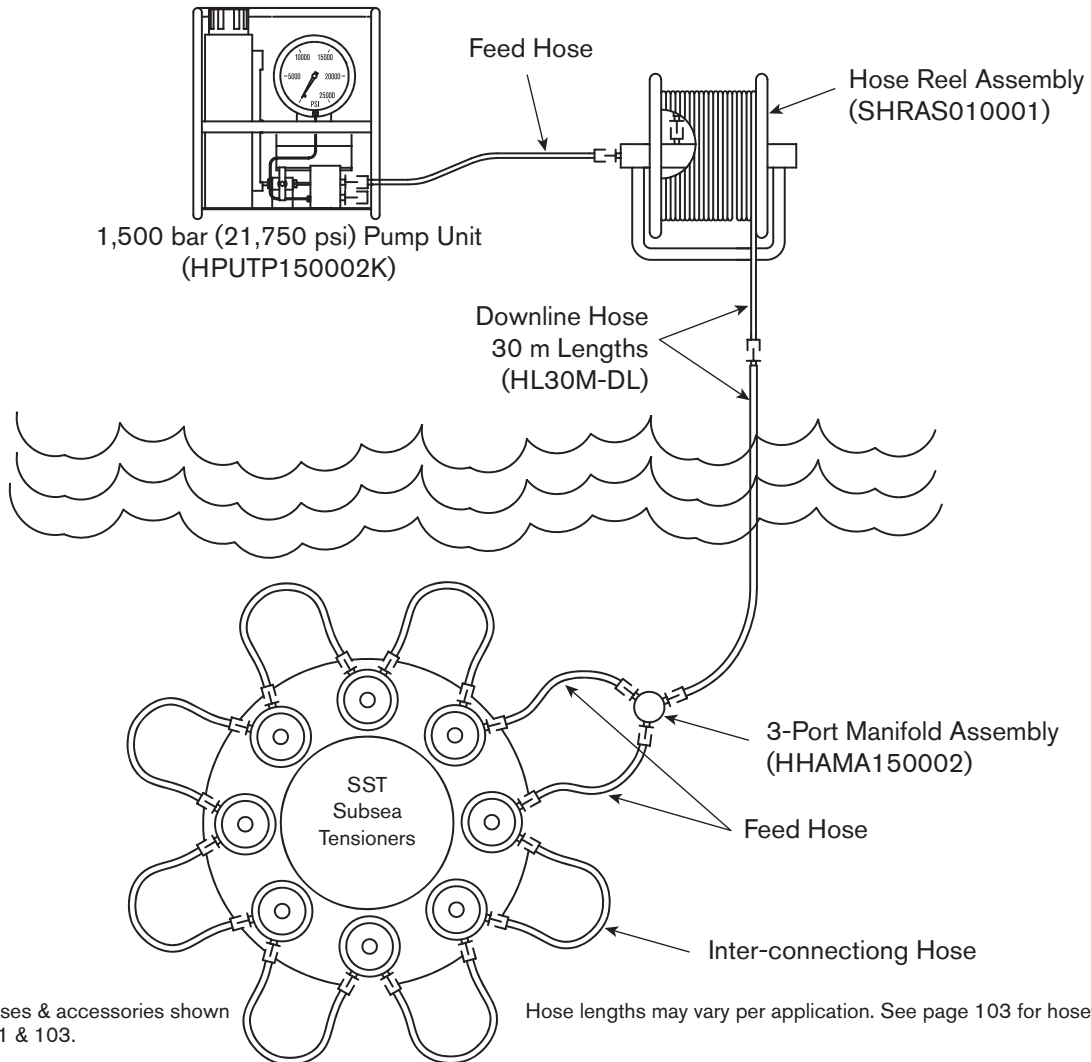

1,500 bar hoses & accessories shown on pages 101 & 103.

Hose lengths may vary per application. See page 103 for hose options.

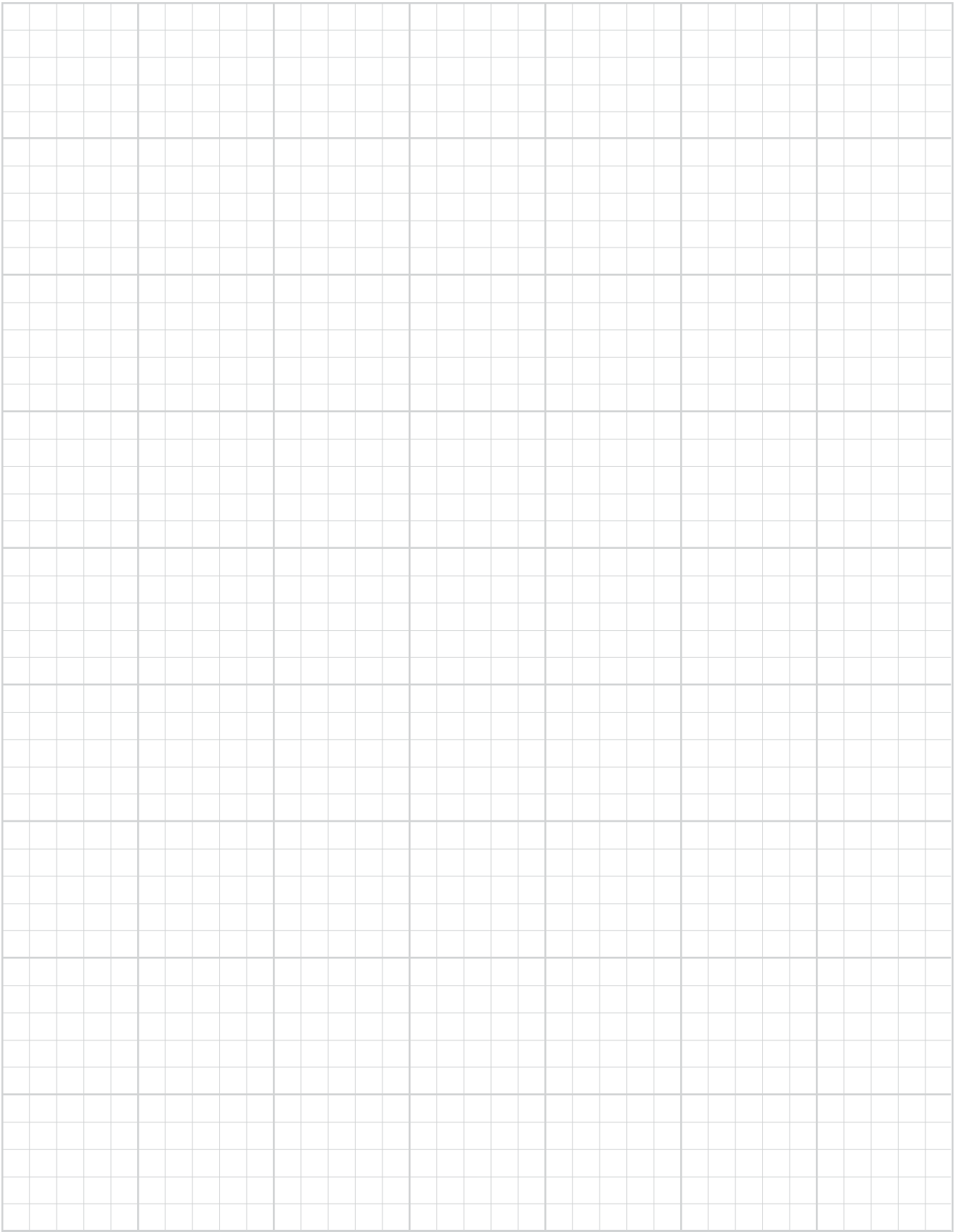

# PUMPS

FOR TORQUE WRENCHES, NUT SPLITTERS & SPREADERS

## 700 BAR (10,000 PSI) - HIGH PERFORMANCE HYDRAULIC PUMPS

Page  
**BOLTING PUMP  
SUMMARY  
CHART...68**

	Torque or Split										Tension
	PE39	PE45	PE55TWP	PE55	PA60A	PA60	RWP55	X1A1-PT	X1E1-PT	PG120TWP	
2000lb	X	X	X	X	X	X	X	X	X	X	X
3000lb	X	X	X	X	X	X	X	X	X	X	X
4000lb	X	X	X	X	X	X	X	X	X	X	X
5000lb	X	X	X	X	X	X	X	X	X	X	X
6000lb	X	X	X	X	X	X	X	X	X	X	X
7000lb	X	X	X	X	X	X	X	X	X	X	X
8000lb	X	X	X	X	X	X	X	X	X	X	X
9000lb	X	X	X	X	X	X	X	X	X	X	X
10000lb	X	X	X	X	X	X	X	X	X	X	X

Page  
**X1E1-PT...78-79**  
Legacy Series Electric  
Hydraulic Pump



Page  
**ISP ADVANTAGE...69**

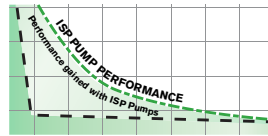

Page  
**PG120TWP...80-81**  
Gas Powered Pump



Page  
**PE45...70-71**  
Infinity Series Electric Pump



Page  
**RWP55-BS...82-83**  
Classic Series Air  
Hydraulic Pump



Page  
**PA60A...72-73**  
Infinity Series Air Pump



Page  
**X1A1-PT...84-85**  
Legacy Series Air  
Hydraulic Pump



Page  
**PE39...74-75**  
Compact Torque Wrench Pump



Page  
**P SERIES...86-87**  
Hand Pumps  
700 bar (10,000 psi)



Page  
**PE55TWP-BS...76-77**  
Classic Series Electric  
Hydraulic Pump



# BOLTING PUMP SUMMARY CHART

Most customers choose to use hand pumps for spreading and nutsplitting applications because of their ability to spread and hold. When using spreaders with torque wrench pumps, use only the top port advance and know that the spreader will retract when the pump is turned off.

**Bold Products have higher stocking levels. X**

		Torque or Split							Tension				
		PE39	PE45	PE55TWP-BS	X1E#-PT	PG120TWP	PA60A	RWP55-BS	RWP55-Dual	X1A1-PT	PE8	HPUTP-1	HPUTP-2
POWER SOURCE	ELECTRIC (110/115V)	X	X	X	X						X		
	ELECTRIC (220/230V)	X	X	X	X						X		
	AIR						X	X	X	X		X	X
	GAS					X							
ELECTRIC MOTOR TYPE	UNIVERSAL	X	X	X	X	n/a					X		
	INDUCTION					n/a							
MAX PRESSURE	10,000 PSI (700 BAR)	X	X	X	X	X	X	X	X	X			
	21,750 PSI (1,500 BAR)										X	X	X
PUMP TYPE	TWO-STAGE	X		X	X		X	X	X	X	X		
	INFINITE STAGE (ISP)		X				X						
FLOW RATE @MAX PRESSURE	LOW (<20 IN <sup>3</sup> /MIN, <0.33 L/min)										X		
	MED. (<40 IN <sup>3</sup> /MIN, <0.66 L/min)	X											
	HIGH (<60 IN <sup>3</sup> /MIN, <0.98 L/min)		X	X	X		X	X		X		X	
	VERY HIGH (>60 IN <sup>3</sup> /MIN, >0.98 L/min)					X			X				X
SPEED @MAX PRESSURE	SLOW	X									X		
	MED			X	X		X		X			X	
	FAST		X			X	X		X				X
APPLICATION TYPE	ORIGINAL INSTALL		X	X	X	X	X	X	X	X	X	X	X
	OPERATIONS/MRO/SERVICE	X		X	X			X		X	X	X	X
DUTY CYCLE	CONTINUOUS		X	X	X	X	X	X	X	X	X	X	X
	INTERMITTENT	X		X	X			X		X	X	X	X
# OF PORTS (TOOL QUANTITY)	1	X	X	X	X	X	X	X	X	X			
	2										X	X	X
	4		X	X			X	X	X				
OIL TANK CAPACITY	0.5 GAL (1.9 L)	X											
	1.0 GAL (3.8 L)										X		
	1.25 GAL (4.7 L)												
	1.5 GAL (5.7 L)		X										
	2.0 GAL (7.6 L)						X						
	2.5 GAL (9.4 L)			X	X			X		X		X	X
	3.0 Gal (11.3 L)					X							
5.0 GAL (18.9 L)								X					
SPECIAL CONSIDERATIONS/ LOCATIONS/ APPLICATIONS *	SUBSEA (UNDERWATER)												X
	WIND/UP-TOWER, TIGHT SPACE	X									X		
	WIND/FOUNDATION TENSION										X	X	X
	ATEX (Ex) II 2 GDc T4						X						
	CE	X	X			X	X				X	X	X
	AUTO CYCLE		X										
	PENDANT INCLUDED	X	X	X	X	X	X	X	X	X	X		
	OPTIONAL COOLER AVAILABLE	X	X					X					

Virtually any pump may be used for Original Installation or Service. This chart factors pump cost and usage together to determine a total cost of ownership and recommends a pump based upon value delivered.

\* Please contact factory of authorized reseller with questions about special applications.

Pumps designed for torque wrench applications do not hold pressure, they should NOT be used for lifting applications and should be used with caution for spreading applications.

The Infinity Stage Pump (ISP) from SPX helps get work done faster. The innovative, patent pending design takes advantage of a continuously variable output that provides maximum flow within the rated pressure range of the pump - from 0 - 700 bar (0 to 10,000 psi). Most torquing and spreading work is done between 70 – 400 bar (1,000 – 6,000 psi), which is where the Infinity Stage Pumps (ISP) provide the most significant advantage over traditional pumps. For example, at 70 bar (1,000 psi) there is 5X as much flow as a traditional two-stage pump. At 275 bar (4,000 psi) there is 2X as much flow as a traditional pump.

## THE ISP ADVANTAGE: INCREASED PRODUCTIVITY

The additional flow moves tools faster which allows work to be done quicker and more efficiently. The increased efficiency saves you time – allowing you to get onto your next job sooner and more profitably.

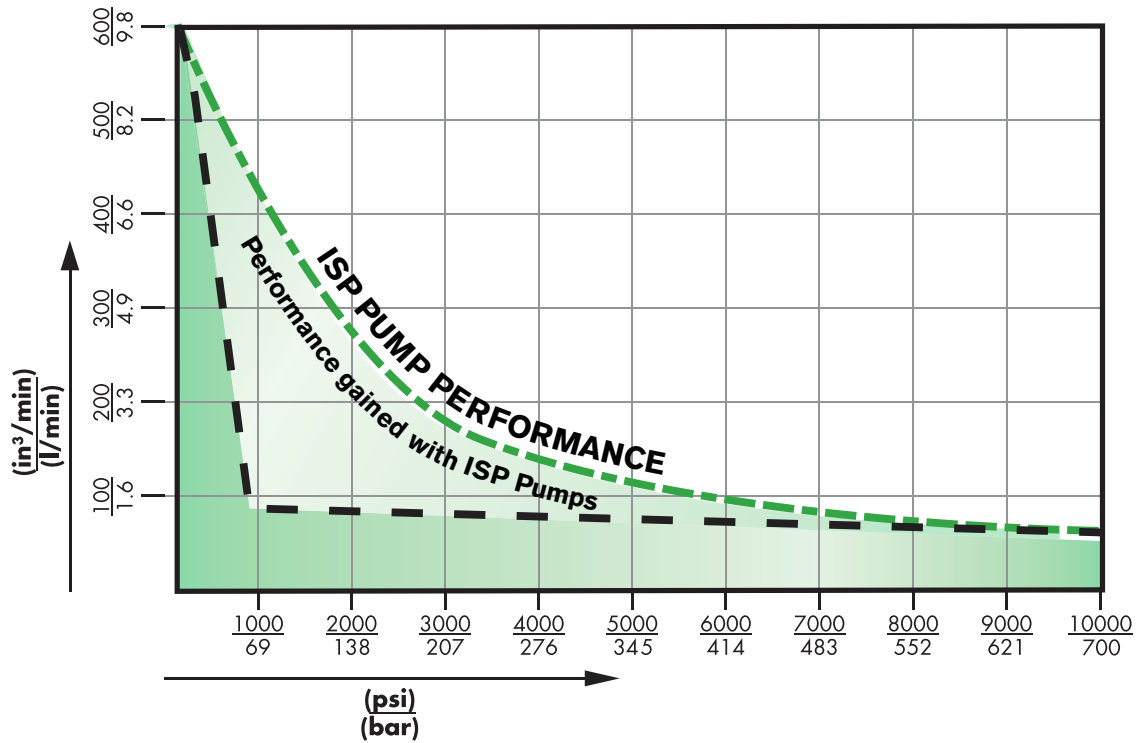

AVAILABLE ON

PE45



PA60A



# INFINITY SERIES ELECTRIC PUMP

PE45  
700 bar/10,000 psi



# 700 BAR (10,000 PSI) INFINITY SERIES (ISP) ELECTRIC PUMP

The SPX PE45 is an Infinite Stage Electric Pump which increases productivity on the job by providing continuous pressure for up to 2x the speed of typical 2-stage pumps. Jobs get done faster and easier.

### Quality means Lower Life-Cycle Costs:

- Over 100,000 cycles
- Continuous duty up to 50°C (122°F) ambient
- Proven design = Proven reliability

### Enhanced Usability:

- Light Weight: 32.2 kg (71 lb) [without oil]
- Removable control pendant (5 m / 15 ft)
- Removable 100mm (4"), calibration-capable gauge
- Universal Motor for reduced voltage applications (up to -20% nominal voltage)
- 4 tool manifold available powers up to 4 tools from a single pump (not for lifting applications)
- High flow to get work done faster

### Designed with Safety in Mind:

- Easily adjusted pressure regulator (relief) valve
- Fixed 103 bar (1,500 psi) retract relief valve pressure

## DESIGNED FOR

Electric



Air



Gas



Hand



MAINTENANCE  
& REPAIR

ORIGINAL  
INSTALL

Split



Tension



Torque



Max  
Flow



## Specifications and Dimensional Data

**Size (L x W x H):** 45 cm x 35.6 cm x 67.5 cm  
17.7" x 14.0" x 26.6"

**Weight:** 32.2 kg (71 lb) [without oil]

**Maximum Oil Capacity:** (vented reservoir)  
6.75 L (1.5 Gallons) [to fill line]  
5.1 L (1.12 Gallons) [usable]

**Operating Environment:**  
-25°C to +50°C (-13°F to +122°F)

(When operating near temperature extremes, it is recommended to use hydraulic oils that are rated for those temperatures. Refer to service manual and cooling option)

**Sound Level:** 87-92 dBA (max)

**Pressure:** 0 - 700 bar (0 - 10,000 psi)

**Typical Flow:** 9.4 L/min - 0.8 L/min  
(575 in<sup>3</sup>/min - 48 in<sup>3</sup>/min)

**Power:** 1.8 hp Universal Motor  
110/115V - 50/60 Hz (17 amps)  
220/230V - 50/60 Hz (8.5 amps)



### Typical Flow Curve

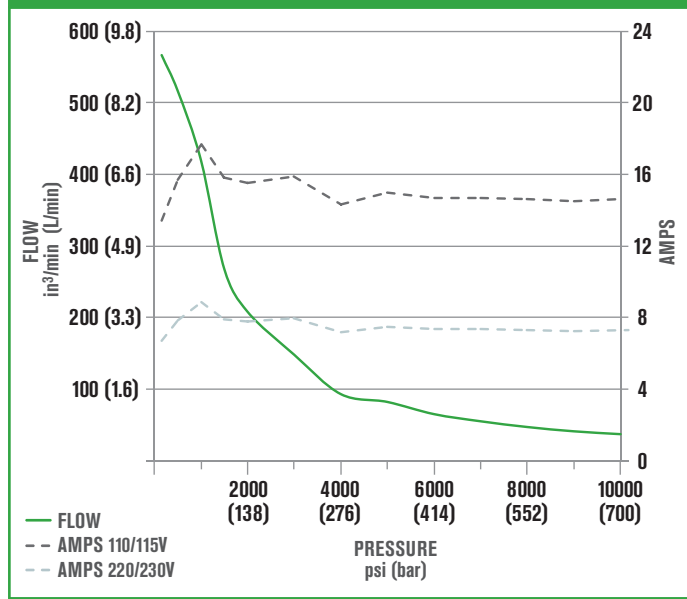

**OPTIONS:**

- Oil Cooling System
- Roll Cage
- 4-Port manifold
- 115V grounded plug pre-installed



Shown with  
Cooling Option

### Ordering Information

PE 45  EE 4    PRS

**Power Source**

**Y** = 110/115 VAC w/plug  
**L** = 110/115 VAC w/flying leads (not stocked)  
**P** = 220/230 VAC w/flying leads

**Auto Cycle**

**Blank** = No Auto Cycle  
**A** = w/Auto Cycle

**Cooling**

**Blank** = w/o cooling  
**C** = w/cooling

**# - Ports**

**Blank** = 1 port (1 tool)  
**M** = 4 ports (4 tools)

Example: PE45YEE4ACMPRS

PE45 Electric Pump with 110/115 VAC Motor with cord with typical grounded 3 prong plug, with Auto Cycle Feature, with active Cooling reservoir and with 4 ports.

# INFINITY SERIES AIR PUMP

PA60A

700 bar/10,000 psi



# 700 BAR (10,000 PSI) INFINITY SERIES (ISP) AIR PUMP

The SPX PA60A is an Infinity Stage Air Pump which increases productivity on the job by providing continuous pressure for up to 2x the speed of typical 2-stage pumps. Jobs get done faster and easier.

### Quality means Lower Life-Cycle Costs:

- Over 100,000 cycles
- Continuous duty up to 50°C (122°F) ambient
- Proven design = Proven reliability

### Enhanced Usability:

- Light weight and portable: 34.9 kg (77 lb) [without oil] PA60APF5FP
- Light weight and portable: 40.1 kg (88 lb) [without oil] PA60APF5FMPR
- Removable control pendant (7.6 m/ 25 ft)
- Removable 100 mm (4"), calibration-capable gauge
- **CE**
- ATEX **Ex** II 2 GDc T4
- 4 port manifold available to power up to 4 tools from a single pump (not for lifting applications)
- Fewer parts for lower service cost

### Designed with Safety in Mind:

- Easily adjusted pressure regulator (relief) valve
- Fixed 103 bar (1,500 psi) retract relief valve pressure

## DESIGNED FOR



MAINTENANCE  
& REPAIR

ORIGINAL  
INSTALL



Max  
Flow





## Specifications and Dimensional Data

**Size (L x W x H):** 50 cm x 36 cm x 51 cm  
19.6" x 14.0" x 20.2" (PA60APF5FMP)

**Size (L x W x H):** 47 cm x 30 cm x 53 cm  
18.6" x 11.8" x 21.0" (PA60APF5FMPR)

**Weight:**

34.9 kg (76.9 lb) [without oil] PA60APF5FP  
36.9 kg (81.5 lb) [without oil] PA60APF5FMP  
37.9 kg (83.7 lb) [without oil] PA60APF5FPR  
40.0 kg (88.3 lb) [without oil] PA60APF5FMPR

**Maximum Oil Capacity:** (vented reservoir)

8.5 L (2.2 Gallons) [to fill line]  
7.0 L (1.8 Gallons) [usable]

**Operating Environment:**

-25°C to +50°C (-13°F to +122°F)

(When operating near temperature extremes, it is recommended to use hydraulic oils that are rated for those temperatures. Refer to service manuals and cooling options)

**Sound Level:** 76 dBA (max)

**Pressure:** 0 - 700 bar (0 - 10,000 psi)

**Typical Flow:** 9.4 L/min - 0.8 L/min  
(575 in<sup>3</sup>/min - 48 in<sup>3</sup>/min)

**Air:** 2.3 m<sup>3</sup>/min @ 5.5 bar (80 cfm @ 80 psi)  
2.5 m<sup>3</sup>/min @ 6.2 bar (90 cfm @ 90 psi)  
2.8 m<sup>3</sup>/min @ 6.9 bar (100 cfm @ 100 psi)

\* Values shown are with filter/regulator/lubricator.  
Values will increase without filter/regulator/lubricator.

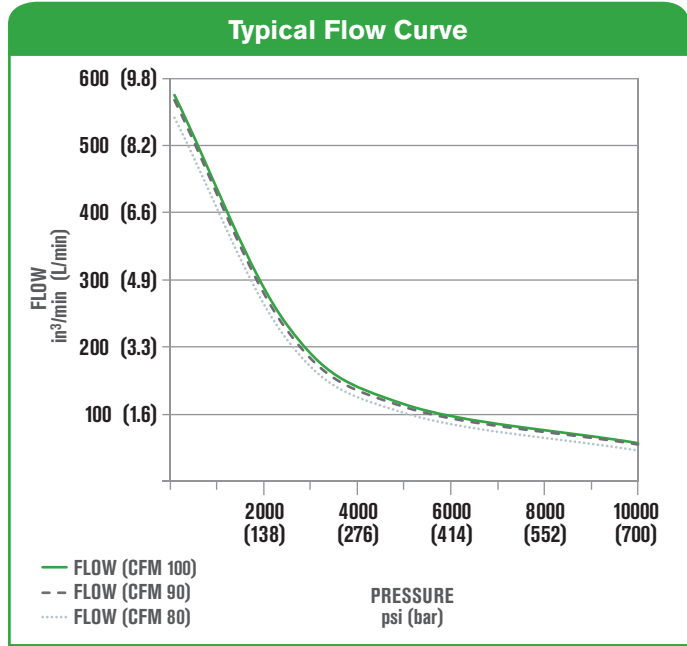

### Hydraulic Oil Delivery

	@ 100 cfm	@ 90 cfm	@ 80 cfm
<b>750 psi</b> <b>51 bar</b>	575 in <sup>3</sup> /min (9.4 L/min)	567 in <sup>3</sup> /min (9.3 L/min)	541 in <sup>3</sup> /min (8.9 L/min)
<b>2,500 psi</b> <b>175 bar</b>	233 in <sup>3</sup> /min (3.8 L/min)	225 in <sup>3</sup> /min (3.7 L/min)	211 in <sup>3</sup> /min (3.4 L/min)
<b>5,000 psi</b> <b>350 bar</b>	115 in <sup>3</sup> /min (1.9 L/min)	111 in <sup>3</sup> /min (1.8 L/min)	102 in <sup>3</sup> /min (1.7 L/min)
<b>10,000 psi</b> <b>700 bar</b>	57 in <sup>3</sup> /min (0.9 L/min)	55 in <sup>3</sup> /min (0.9 L/min)	46 in <sup>3</sup> /min (0.8 L/min)

### Ordering Information

Order No.	Description
<b>PA60APF5FMP</b>	PUMP, ISP 60 CU-IN/MIN, AIR/HYD, 4-PORT
<b>PA60APF5FMPR</b>	PUMP, ISP 60 CU-IN/MIN, AIR/HYD 4-PORT, Roll Cage
<b>PA60APF5FP</b>	PUMP, ISP 60 CU-IN/MIN, AIR/HYD
<b>PA60APF5FPR</b>	PUMP, ISP 60 CU-IN/MIN, AIR/HYD, Roll Cage

# COMPACT ELECTRIC TORQUE WRENCH PUMP

PE39  
700 bar/10,000 psi



# 700 BAR (10,000 PSI) COMPACT ELECTRIC TORQUE WRENCH PUMP

The SPX PE39 is compact and capable of being used in a vertical or horizontal orientation. Based on proven pump design for reliability in rugged torque wrench applications to support operation and maintenance requirements.

### Quality means Lower Life-Cycle Costs:

- Over 100,000 cycles
- Continuous duty up to 50°C (122°F) ambient
- Proven design = proven reliability

### Enhanced Usability:

- Light weight and portable: 17.7 kg (39 lb)
- Removable control pendant (5 m/15 ft cord length)
- Removable 100 mm (4") calibration-capable gauge
- Universal Motor for reduced voltage applications (up to -20% nominal voltage)
- Vertical or horizontal operation
- Easy install cooling fan as option

### Designed with Safety in Mind:

- Easily adjusted pressure regulator (relief) valve
- Fixed 103 bar (1,500 psi) retract relief valve pressure

## DESIGNED FOR

Electric



Air



Gas



Hand



MAINTENANCE & REPAIR

ORIGINAL INSTALL

Split



Tension



Torque



Max Flow



To be used with torque wrenches, pages 11-33

## Specifications and Dimensional Data

**Size (L x W x H):** 35 cm x 27.4 cm x 60 cm  
13.8" x 10.8" x 23.7"

**Weight:** 17.7 kg (39 lb) [without Oil]

**Maximum Oil Capacity:** (non-vented reservoir)  
1.9 L (0.5 Gallons) [to fill line]  
1.5 L (0.4 Gallons) [usable]

**Operating Environment:** -25°C to +50°C  
(-13°F to +122°F)

(When operating near temperature extremes, it is recommended to use hydraulic oils that are rated for those temperatures. Refer to service manuals and cooling options)

**Sound Level:** 87 – 92 dBA (max)

**Pressure:** 0 - 700 bar (0 - 10,000 psi)

**Typical Flow:** 3.7 L/min - 0.64 L/min  
(225 in<sup>3</sup>/min - 39 in<sup>3</sup>/min)

**Power:** 1.3 hp Universal Motor  
110/115V - 50/60 Hz (14.5 amps)  
220/230V - 50/60 Hz (7.2 amps)



### Typical Flow Curve

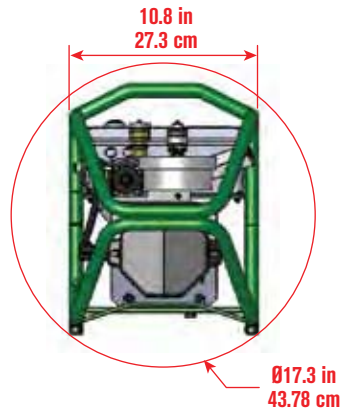
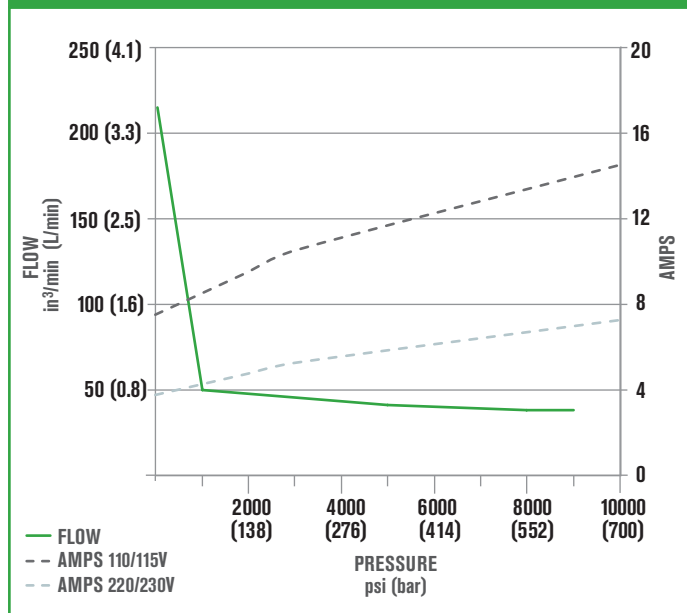

Vertical or Horizontal Operation

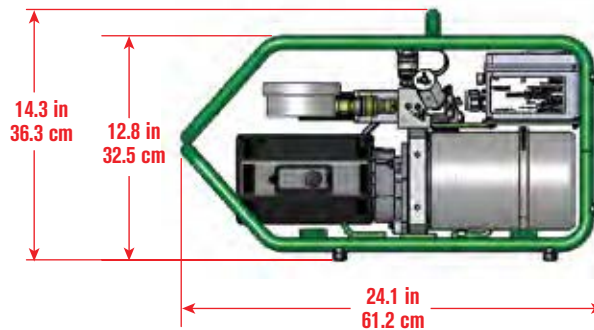

## Ordering Information

Order No.	Description
<b>PE39YED1PR</b>	110/115VAC
<b>PE39YED1BPR</b>	110/115VAC with cooling option
<b>PE39PED1PR</b>	220/230VAC
<b>PE39PED1BPR</b>	220/230VAC with cooling option

### OPTIONS

- Auxilliary Cooling Fan (Field Installable)  
Order No. 3000610

# CLASSIC SERIES ELECTRIC HYDRAULIC PUMP

PE55TWP-BS  
700 bar/10,000 psi



# 700 BAR (10,000 PSI) CLASSIC SERIES ELECTRIC HYDRAULIC PUMP

The PE55TWP-BS has been the market leading electric pump for over 30 years & is therefore tried & tested. A simple, light-weight design with a recent upgrade that has created a cost-effective workhorse.

### Quality means Lower Life-Cycle Costs:

- Over 100,000 cycles
- Continuous duty up to 50°C (122°F) ambient
- Proven design = Proven reliability

### Enhanced Usability:

- Two Speed High Performance pump
- Retract side internal relief valve protects tool
- Hand remote
- Four-tool manifold (-4 models only) allow use of up to four tools simultaneously
- 4" calibration capable gauge
- Use with single or double acting tools

### Designed with Safety in Mind:

- Easily adjusted pressure regulator (relief) valve
- 103 bar (1,500 psi) pressure retract relief valve

## DESIGNED FOR



MAINTENANCE & REPAIR

ORIGINAL INSTALL



Max Flow



## Specifications and Dimensional Data

**Size (L x W x H):** 147 cm x 24 cm x 49 cm  
18.5" x 9.5" x 19.2"

**Weight:** 29.5 kg (65 lb) [without oil]

**Maximum Oil Capacity:** (vented reservoir)  
6.8 L (1.8 Gallons) [to fill line]  
5.3 L (1.4 Gallons) [usable]

**Operating Environment:** -25°C to +50°C  
(-13°F to +122°F)

(When operating near temperature extremes, it is recommended to use hydraulic oils that are rated for those temperatures. Refer to service manuals and cooling options)

**Sound Level:** 87-92 dBA (max)

**Pressure:** 0 - 700 bar (0 - 10,000 psi)

**Typical Flow:** 11.5 L/min - 0.9 L/min  
(704 in<sup>3</sup>/min - 56 in<sup>3</sup>/min)

**Power:** 1-1/8 hp Universal Motor  
110/115V - 50/60 Hz (25 amps)  
220/230V - 50/60 Hz (13 amps)

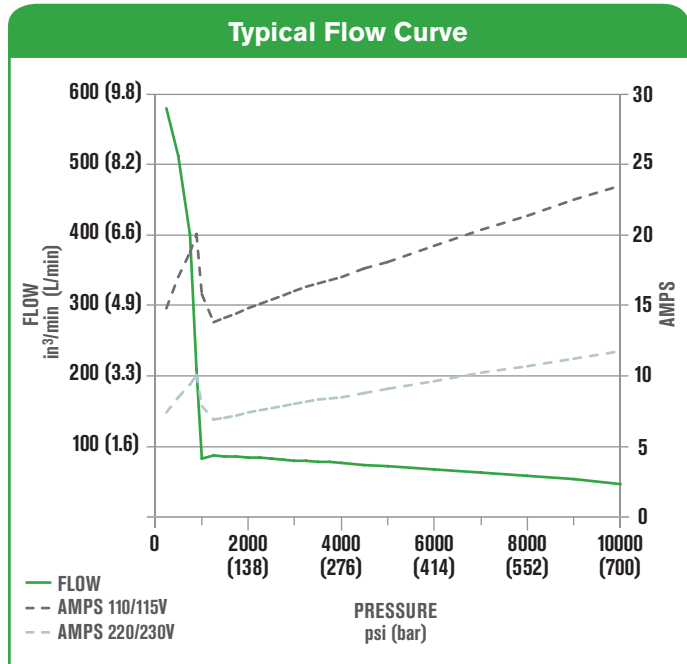

Order No.	Oil Delivery per min.	Oil Reservoir gal	Usable Oil in <sup>3</sup>	Overall Width	Overall Length	Overall Height	Pump Weight w/Oil
PE55TWP-BS PE55TWP-220-BS	704 in <sup>3</sup> @ 100 psi 11.5 L/min @ 6.9 bar	2.5	324	17.14" 435 mm	9.5" 241 mm	18.12" 460 mm	75 lb 34 kg
	56 in <sup>3</sup> @ 10,000 psi 0.9 L/min @ 700 bar						
PE55TWP-4-BS PE55TWP-4-CF-BS PE55TWP-4-220-BS	704 in <sup>3</sup> @ 100 psi 11.5 L/min @ 6.9 bar	2.5	324	18.49" 470 mm	9.5" 241 mm	19.15" 487 mm	78 lb 35.5 kg
	56 in <sup>3</sup> @ 10,000 psi 0.9 L/min @ 700 bar						

### Electrical Data

	Electric Motor	Electrical Control
PE55TWP-BS PE55TWP-4-BS PE55TWP-4-CF-BS	1-1/8 hp, 12000 rpm 110/150V, 50/60Hz, 25 amps	Remote control with 20-foot cord
PE55TWP-220-BS PE55TWP-4-220-BS	1-1/8 hp, 12000 rpm 220/230V, 50/60Hz, 13 amps	

### Ordering Information

Order No.	Description
PE55TWP-BS	110/115V, 50/60 Hz, Single Tool
PE55TWP-4-BS	110/115V, 50/60 Hz, 4 Tool
PE55TWP-4-CF-BS	110/115V, 50/60 Hz, 4 Tool, with Cooling Fan
PE55TWP-220-BS	220/230V, 50/60 Hz, Single Tool
PE55TWP-4-220-BS	220/230V, 50/60 Hz, 4 Tool

Contact factory for CE pump options

## LEGACY SERIES ELECTRIC HYDRAULIC PUMP

X1E1-PT  
700 bar/10,000 psi



## 700 BAR (10,000 PSI) CLASSIC SERIES ELECTRIC HYDRAULIC PUMP

The original electric pump! Features a simplified electrical control box and a proven, reliable design. Typically sold to customers that already have a fleet of similar pumps.

### Quality means Lower Life-Cycle Costs:

- Over 100,000 cycles
- Continuous duty up to 50°C (122°F) ambient
- Proven design = Proven reliability

### Enhanced Usability:

- Power Team, two-speed high performance, PE55 base pump
- Retract side internal relief valve protects tool
- 4-way 2-position solenoid valve standard
- Use with single or double acting tools, not for lifting applications
- Hand remote standard

### Designed with Safety in Mind:

- Easily adjusted pressure regulator (relief) valve
- Fixed 103 bar (1,500 psi) pressure retract relief valve

### DESIGNED FOR



MAINTENANCE  
& REPAIR

ORIGINAL  
INSTALL



Max  
Flow



## Specifications and Dimensional Data

**Size (L x W x H):** 35 cm x 33 cm x 46 cm  
13.9" x 13.1" x 18.1"

**Weight:** 35.3 kg (78 lb) [without oil]

**Maximum Oil Capacity:** (vented reservoir)  
6.8 L (1.8 Gallons) [to fill line]  
5.3 L (1.4 Gallons) [usable]

**Operating Environment:** -25°C to +50°C  
(-13°F to +122°F)

(When operating near temperature extremes, it is recommended to use hydraulic oils that are rated for those temperatures. Refer to service manuals and cooling options)

**Sound Level:** 87-92 dBA (max)

**Pressure:** 0 - 700 bar (0 - 10,000 psi)

**Typical Flow:** 11.5 L/min - 0.9 L/min  
(704 in<sup>3</sup>/min - 55 in<sup>3</sup>/min)

**Power:** 1-1/8 hp Universal Motor  
110/115V - 50/60 Hz (25 amps)  
220/230V - 50/60 Hz (13 amps)

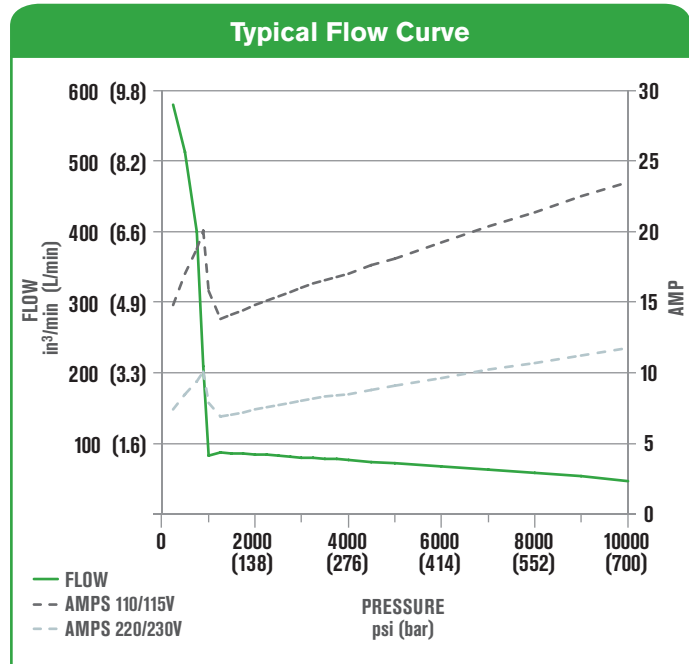

Order No.	Oil Delivery per min.	Oil Reservoir	Usable Oil	Overall Width	Overall Length	Overall Height	Pump Weight w/Oil
		gal L	in <sup>3</sup> L	in cm	in cm	in cm	lb kg
X1E1-PT	55 in <sup>3</sup> @ 10,000 psi	2.5	324	13.9	13.1	18.1	90
	0.9 L @ 700 bar	9.5	5.3	35	33	46	41

### Electrical Data

	Electric Motor	Electrical Control
X1E1-PT	1-1/8 hp, 12000 rpm 110/115V, 50/60 Hz, 25 amps	Remote control with 20-foot cord

### Ordering Information

Order No.	Description
X1E1-PT	110/115V, 50/60 Hz, Single Tool
X1E2-PT	220/230V, 50/60 Hz, Single Tool

# CLASSIC SERIES GAS HYDRAULIC PUMP

PG120TWP  
700 bar/10,000 psi



# 700 BAR (10,000 PSI) CLASSIC SERIES GAS HYDRAULIC PUMP

Gasoline powered pump for use in remote locations where electricity or compressed air are not readily available.

Operates on a powerful 5.5 hp Honda OHV-type engine.

### Quality means Lower Life-Cycle Costs:

- High quality, reliable gasoline engine
- Continuous duty
- Proven design = proven reliability

### Enhanced Usability:

- Air cooled 4-stroke engine
- Uses standard unleaded gasoline
- Large capacity, multi-chamber exhaust system to reduce noise

### Designed with Safety in Mind:

- Fixed 48 bar (700 psi) UnLoad Valve
- Frame allows for easy two man carry

## DESIGNED FOR



MAINTENANCE & REPAIR

ORIGINAL INSTALL



Max Flow





## Specifications and Dimensional Data

**Size (L x W x H):** 54 cm x 50 cm x 59 cm  
21.25" x 19.75" x 23"

**Weight:** 55 kg (121 lb) [without oil]

**Maximum Oil Capacity:** (vented reservoir)  
10.2 L (2.7 Gallons) [to fill line]  
9.4 L (2.5 Gallons) [usable]

**Operating Environment:** -25°C to +50°C  
(-13°F to +122°F)

(When operating near temperature extremes, it is recommended to use hydraulic oils that are rated for those temperatures. Refer to service manuals and cooling options)

**Sound Level:** 85-92 dBA (max)

**Pressure:** 0 - 700 bar (0 - 10,000 psi)

**Typical Flow:** 7.87 L/min - 2.13 L/min  
(480 in<sup>3</sup>/min - 130 in<sup>3</sup>/min)

**Power:** 5.5 hp Honda OHV-Type Gasoline Engine, 3600 rpm

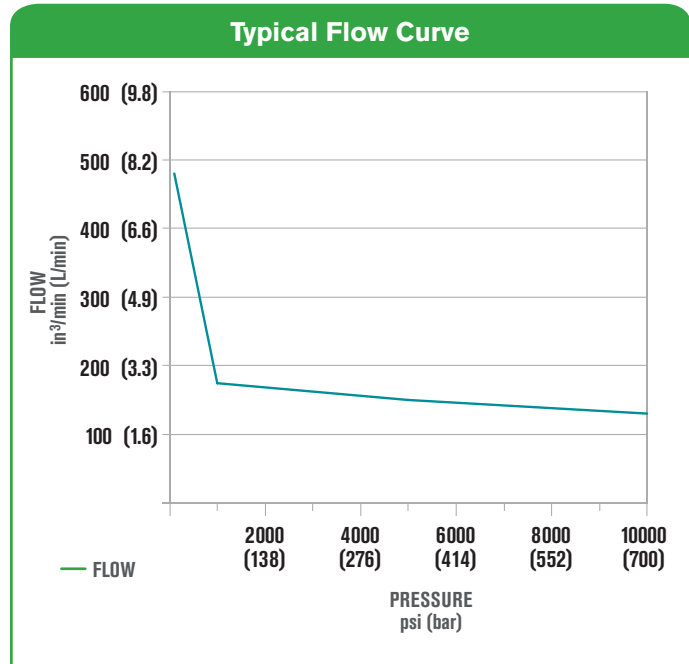

Order No.	Oil Delivery per min.		Oil Reservoir	Usable Oil	Overall Width		Overall Length		Overall Height		Pump Weight w/Oil	
	480 in <sup>3</sup> @ 100 psi	7.87 L/min @ 100 psi	gal	in <sup>3</sup>	in	cm	in	cm	in	cm	lb	kg
PG120TWP	130 in <sup>3</sup> @ 10,000 psi	2.13 L/min @ 10,000 psi	3	572	19.75	50	21.25	54	23	59	126	57.2

## Ordering Information

Order No.	Description
PG120TWP	Gasoline Pump, Single Tool

## CLASSIC SERIES AIR HYDRAULIC PUMP

RWP55-BS  
700 bar/10,000 psi



## 700 BAR (10,000 PSI) CLASSIC SERIES AIR HYDRAULIC PUMP

The RWP55-BS has been the market leading pump for over 30 years & is therefore tried & tested. A simple, light-weight design with a recent upgrade that has created a cost-effective workhorse.

### Quality means Lower Life-Cycle Costs:

- Over 100,000 cycles
- Continuous duty up to 50°C (122°F) ambient
- Proven design = Proven reliability

### Enhanced Usability:

- Powerful 3 hp motor starts under load
- Retract side internal relief valve protects tool
- Use with single or double acting tools. Not for lifting applications
- 4" calibration capable gauge

### Designed with Safety in Mind:

- Easily adjusted pressure regulator (relief) valve
- Has a retract port pressure selector 1,500 or 10,000 psi

### DESIGNED FOR

Electric



Air



Gas



Hand



MAINTENANCE  
& REPAIR

ORIGINAL  
INSTALL

Split



Tension



Torque



Max  
Flow



## Specifications and Dimensional Data

**Size (L x W x H):** 42 cm x 24 cm x 50 cm  
16.6" x 9.5" x 19.8"

**Weight:** 38 kg (84 lb) [without oil]

**Maximum Oil Capacity:** (vented reservoir)  
6.8 L (1.8 Gallons) [to fill line]  
5.3 L (1.4 Gallons) [usable]

**Operating Environment:** -25°C to +50°C  
(-13°F to +122°F)

(When operating near temperature extremes, it is recommended to use hydraulic oils that are rated for those temperatures. Refer to service manuals and cooling options)

**Sound Level:** 85-92 dBA (max)

**Pressure:** 0 - 700 bar (0 - 10,000 psi)

**Typical Flow:** 7.6 L/min - 0.9 L/min  
(465 in<sup>3</sup>/min - 55 in<sup>3</sup>/min)

**Air:** 1.4 m<sup>3</sup>/min @ 5.5 bar (50 cfm @ 80 psi)  
1.65 m<sup>3</sup>/min @ 6.2 bar (58 cfm @ 90 psi)  
1.89 m<sup>3</sup>/min @ 6.9 bar (67 cfm @ 100 psi)

\* Values shown are with filter/regulator/lubricator.  
Values will increase without filter/regulator/  
lubricator.

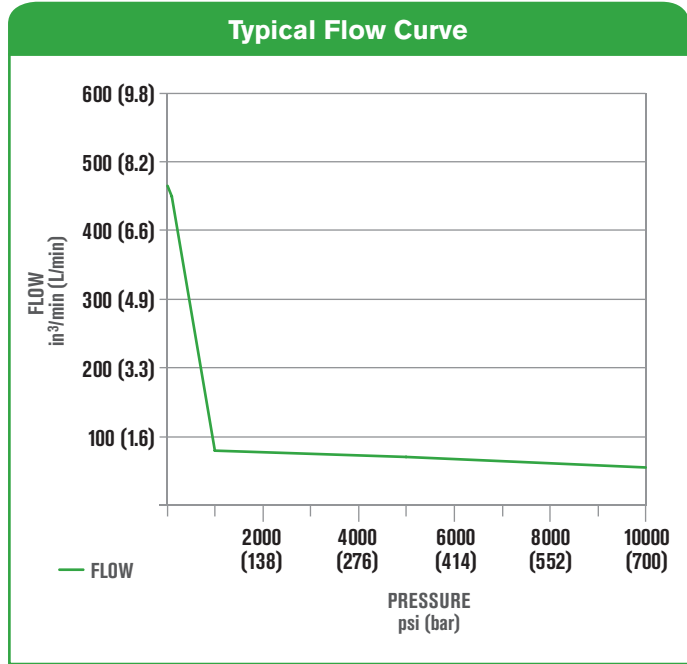

Order No.	Oil Delivery per min	Oil Reservoir gal	Usable Oil in <sup>3</sup>	Overall Width in	Overall Length in	Overall Height in	Pump Weight w/Oil lb
RWP55-BS	465 in <sup>3</sup> @ 100 psi	2.5	324	16.55	9.5	19.83	98
	55 in <sup>3</sup> @ 10,000 psi						
RWP55-4-BS (4-tool manifold)	465 in <sup>3</sup> @ 100 psi	2.5	324	16.55	9.5	19.83	98
	55 in <sup>3</sup> @ 10,000 psi						

### Motor Data

	Air Motor	Air Control
RWP55-BS	3 hp, 50 cfm @ 80 psi	Pneumatic remote control with 25-foot cord

### Ordering Information

Order No.	Description
RWP55-BS	Air Pump, Single tool
RWP55-BS-R	Air Pump, Single tool, with roll cage
RWP55-4-BS	Air Pump, 4 tool
RWP55-4-BS-R	Air Pump, 4 tool, with roll cage

## LEGACY SERIES AIR HYDRAULIC PUMP

X1A1-PT  
700 bar/10,000 psi



## 700 BAR (10,000 PSI) CLASSIC SERIES AIR HYDRAULIC PUMP

The original air pump! Features a proven, reliable design. Typically sold to customers that already have a fleet of similar pumps.

### Quality means Lower Life-Cycle Costs:

- Over 100,000 cycles
- Continuous duty up to 50°C (122°F) ambient
- Proven design = Proven reliability

### Enhanced Usability:

- Power Team, two-speed high performance, PA55 base pump
- Retract side internal relief valve protects tool
- 4-way 2-position air pilot valve standard
- Use with single or double acting tools. Not for lifting applications.
- Hand remote standard

### Designed with Safety in Mind:

- Easily adjusted pressure regulator (relief) valve
- Fixed 103 bar (1,500 psi) pressure retract relief valve

### DESIGNED FOR



MAINTENANCE  
& REPAIR

ORIGINAL  
INSTALL



Max  
Flow



## Specifications and Dimensional Data

**Size (L x W x H):** 27 cm x 46 cm x 48 cm  
10.8" x 18" x 18.8"

**Weight:** 34 kg (75 lb) [without oil]

**Maximum Oil Capacity:** (vented reservoir)  
6.8 L (1.8 Gallons) [to fill line]  
5.3 L (1.4 Gallons) [usable]

**Operating Environment:** -25°C to +50°C  
(-13°F to +122°F)

(When operating near temperature extremes, it is recommended to use hydraulic oils that are rated for those temperatures. Refer to service manuals and cooling options)

**Sound Level:** 85-92 dBA (max)

**Pressure:** 0 - 700 bar (0 - 10,000 psi)

**Typical Flow:** 7.6 L/min - 0.9 L/min  
(465 in<sup>3</sup>/min - 55 in<sup>3</sup>/min)

**Air:** 1.4 m<sup>3</sup>/min @ 5.5 bar (50 cfm @ 80 psi)  
1.65 m<sup>3</sup>/min @ 6.2 bar (58 cfm @ 90 psi)  
1.89 m<sup>3</sup>/min @ 6.9 bar (67 cfm @ 100 psi)

\* Values shown are with filter/regulator/lubricator.  
Values will increase without filter/regulator/  
lubricator.

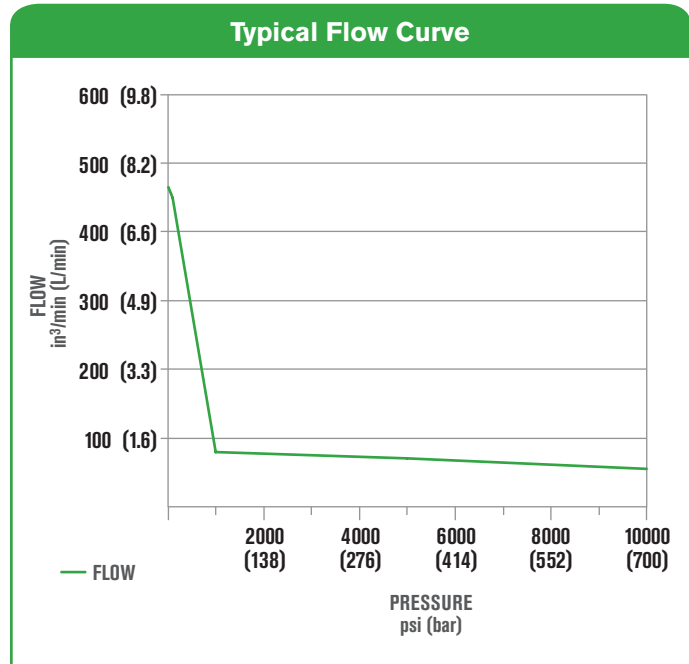

Order No.	Oil Delivery per min.	Oil Reservoir gal	Usable Oil in <sup>3</sup>	Overall Width in	Overall Length in	Overall Height in	Pump Weight w/Oil lb
X1A1-PT	465 in <sup>3</sup> @ 100 psi	2.5	324	10.75	18	18.75	89
	55 in <sup>3</sup> @ 10,000 psi						

## Ordering Information

Order No.	Description
<b>X1A1-PT</b>	Air Pump, Single tool

# HAND PUMPS

## HYDRAULIC P SERIES

700 bar/10,000 psi



### PUMP AUTOMATICALLY SHIFTS INTO THE HIGH PRESSURE STAGE UPON CONTACT WITH THE LOAD.

- All metal construction won't burn through in welding environments.
- Two-speed reduces handle strokes so you work faster and easier.
- Convenient fill port allows pumps to be filled in a horizontal or vertical position.
- Relief valve inboard of check valve prevents loads from drifting down.
- Large valve knob gives added control for slowly metering loads down.

#### P19L/P59L

- More usable oil volume — use with larger or longer stroke cylinders.
- True unloading valve set for 59 bar (850 psi) provides more efficiency and lower handle force.
- Link design reduces handle effort by 40%.
- Durable aluminum reservoir, manifold, and end cap.
- Ergonomic non-slip handle grip provides more comfort.
- Spring loaded handle lock incorporated into handle.

#### P59F

- Steel Reservoir
- Strong lever
- Lower handle effort (measured)
- Higher unloading pressure 22 bar (325 psi)
- Looks better (professional)
- Pump is serviceable (all components available)
- Strong aluminum head (not plastic)
- More usable oil
- No breather opening needed (so no leakage)
- Color consistency
- True unloading (more flow/ lower effort)
- Pump mounting holes on front and back
- Solid accurate repeatable Integrated lifting system
- Can be used in welding environment (no plastic)

#### DESIGNED FOR

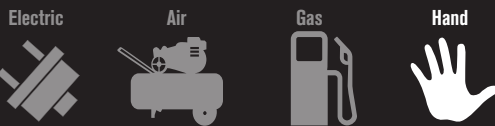

**MAINTENANCE & REPAIR**

**ORIGINAL INSTALL**



**Max Flow**



No coupler included with these pumps.

## Specifications and Dimensional Data

**Operating Environment:** -25°C to +50°C  
(-13°F to +122°F)

(When operating near temperature extremes, it is recommended to use hydraulic oils that are rated for those temperatures. Refer to service manuals and cooling options)

**Pressure:** 0 - 700 bar (0 - 10,000 psi)

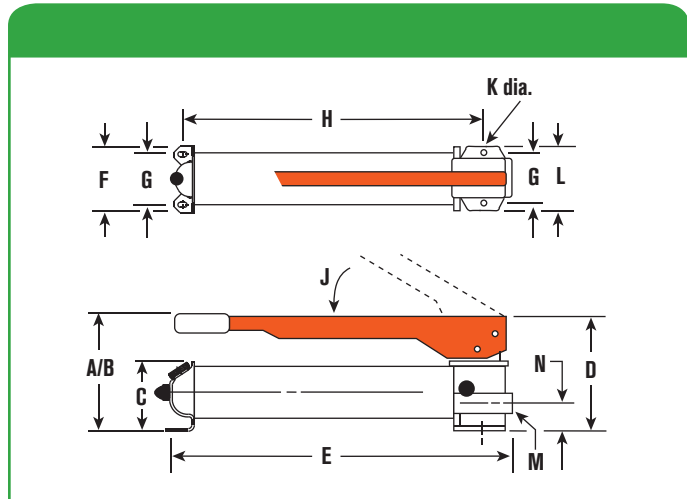

Order No.	A in	B in	C in	D in	E in	F in	G in	H in	J deg	K in	L in	M in	N in
P19	5-1/2	14-5/8	2-7/8	4-9/16	13-11/16	4	3-1/4	11-1/16	53°	5/16	4	3/8 NPTF	1-13/32
P19L	5-1/2	—	—	—	13-11/16	4-1/8	3-1/4	11	40°	5/16	—	3/8 NPTF	—
P59	7	21	3-1/2	5	23	4-1/4	3-1/4	19-3/4	38°	5/16	4-3/4	3/8 NPTF	1-5/8
P59L	7	—	—	—	21	5	3-1/4	19-3/4	50°	5/16	—	3/8 NPTF	—
P59F	3-1/2	16-3/4	3-1/2	6	23-1/4	4-1/4	3-1/4	20-1/4	—	5/16	4-1/2	3/8 NPTF	—

## Ordering Information

For Use With	Order No.	Speed	Volume & Pressure				Reservoir Handle Effort lb	Oil Capacity cu in	Usable Oil Capacity cu in	Oil Port in	Product Weight lb
			Volume per Stroke (cu. in.)		Maximum Pressure (psi)						
			LP	HP	LP	HP					
Single Acting	P19	2	0.305	0.076	325	10,000	99	24.4	20	3/8 NPTF	6.6
	P19L	2	0.250	0.050	850	10,000	78	29	27	3/8 NPTF	5.1
	P59	2	0.662	0.160	325	10,000	145	55	45	3/8 NPTF	17.2
Tools & Cylinders*	P59L	2	0.720	0.150	850	10,000	104	69	66	3/8 NPTF	8.9
	P59F	2	0.550	0.130	325	10,000	120	55	45	3/8 NPTF	14

LP = Low Pressure

HP = High Pressure

\*Pump includes 2-Way Valve



### Foot Pump Conversion Kit

**No. FK59** - Foot pump conversion kit for use on P55/P59 pumps. Wt., 6 lb

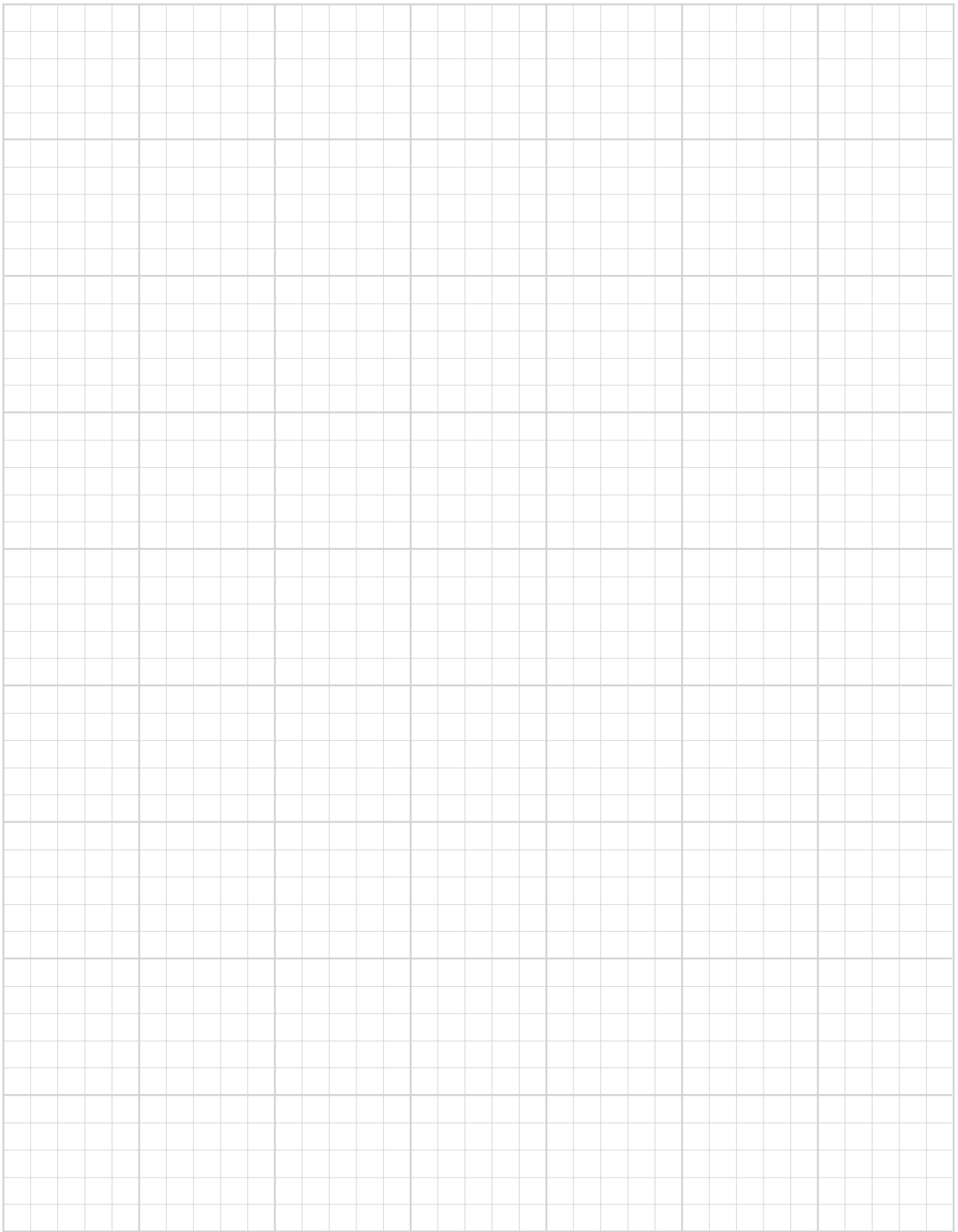



# PUMPS

FOR TENSIONERS

**1,500 BAR (21,750 PSI) - HIGH PERFORMANCE HYDRAULIC PUMPS**

Page  
**PE8...90-91**  
High Pressure Electric Pump



Page  
**HPUTP-2...94-95**  
High Flow & Subsea Tensioner  
Power Pack



Page  
**HPUTP-1...92-93**  
Standard Flow Tensioner  
Power Pack



Page  
**HIGH PRESSURE  
HAND PUMPS...96-97**  
1,500 bar (21,750 psi)



## SIDE BY SIDE COMPARISON OF HPUTP-1 AND HPUTP-2 PUMPS

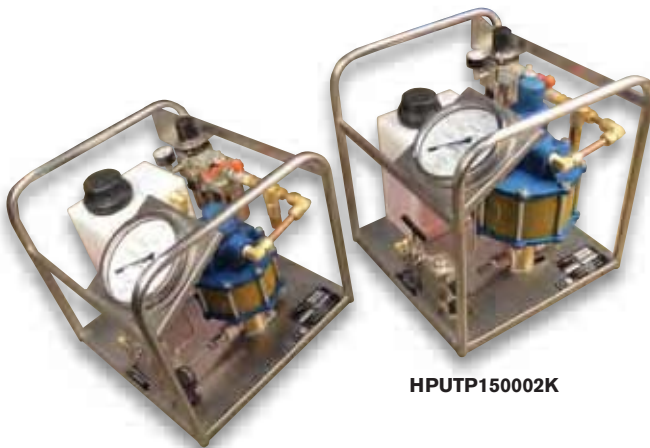

HPUTP150001K

HPUTP150002K

The HPUTP-2 produces more flow, has a larger motor and frame and weighs approximately 4 kg (9 lb) more.



**CAUTION!** These pumps can produce pressure in excess of 10,000 psi (700 bar). Check all components that are used with these pumps and never exceed the rated pressure of any component.

# HIGH PRESSURE ELECTRIC PUMP

PE8

1,500 bar/21,750 psi



# 1,500 BAR (21,750 PSI) HIGH PRESSURE ELECTRIC PUMP

The SPX PE8 is a very high pressure pump that incorporates proven design for reliable operation. It is based on proven pump design for reliability in rugged bolt tensioning applications.

### Quality means Lower Life-Cycle Costs:

- Over 100,000 cycles
- Continuous duty up to 50°C (122°F) ambient
- Proven design = Proven reliability

### Enhanced Usability:

- Light Weight and portable: 20.6 kg (45.5 lb) [without oil]
- Quick Release, removable control pendant (5 m / 15 ft)
- Removable 100 mm (4"), calibration-capable, gauge
- Universal Motor for reduced voltage applications (up to -20% nominal voltage)
- SPX Tensioners are designed to daisy-chain together so multiple tools can run off one pump
- Compact design fits into tight spaces

### Designed with Safety in Mind:

- Easily adjusted pressure regulator (relief) valve

## DESIGNED FOR

Electric



Air



Gas



Hand



MAINTENANCE & REPAIR

ORIGINAL INSTALL

Split



Tension



Torque



Max Flow



## Specifications and Dimensional Data

**Size (L x W x H):** 35.8 cm x 19.8 cm x 41.4 cm  
14.1" x 7.8" x 16.3"

**Weight:** 20.6 kg (45.5 lb) [without oil]

**Maximum Oil Capacity:** (vented reservoir)  
3.8 L (1.0 Gallons) [to fill line]  
3.4 L (0.9 Gallons) [usable]

**Operating Environment:** -25°C to +50°C  
(-13°F to +122°F)

(When operating near temperature extremes, it is recommended to use hydraulic oils that are rated for those temperatures. Refer to service manuals and cooling options)

**Sound Level:** 87-92 dBA (max)

**Pressure:** 0 - 1,500 bar (0 - 21,750 psi)

**Typical Flow:** 2.7 L/min - 0.13 L/min  
(168 in<sup>3</sup>/min - 8 in<sup>3</sup>/min)

**Power:** 0.5 hp Universal Motor  
110/115V - 50/60 Hz (11 amps)  
220/230V - 50/60 Hz (5.5 amps)

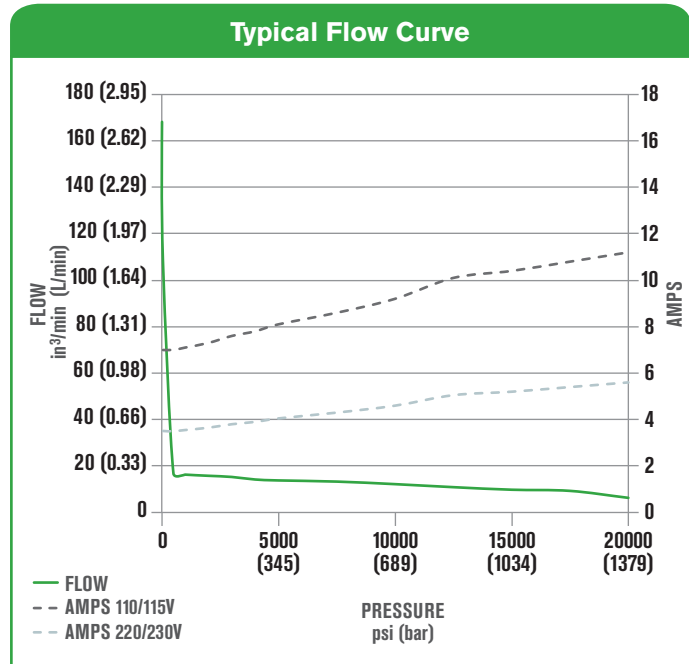

## Ordering Information

Order No.	Description
<b>PE8LXX3L</b>	110/115VAC 50/60Hz Motor
<b>PE8PXX3L</b>	220/230VAC 50/60Hz Motor

## STANDARD FLOW TENSIONER PUMP

HPUTP-1  
1,500 bar/21,750 psi



HPUTP150001K

## 1,500 BAR (21,750 PSI) TOPSIDE BOLT TENSIONER & HYDRAULIC NUT PUMP

Standard flow tension pump. Corrosion resistant frame works well for applications near salt water. Standard flow ideal for land based (topside) tension applications where the required power source is compressed air.

### Quality means Lower Life-Cycle Costs:

- Over 100,000 cycles
- Continuous duty up to 50°C (122°F) ambient
- Proven design = Proven reliability

### Enhanced Usability:

- Calibrated 150 mm (6") Pressure Gauge
- Dual oil outlets with quick-connect, no spill couplings
- Pneumatic Filter/Regulator/Lubricator included
- Stainless Steel carrying frame

### Designed with Safety in Mind:

- Easily adjusted pressure regulator valve
- Air pressure safety relief valve

### DESIGNED FOR



MAINTENANCE  
& REPAIR

ORIGINAL  
INSTALL



Max  
Flow



## Specifications and Dimensional Data

**Size (L x W x H):** 42 cm x 42 cm x 39 cm  
16.5" x 16.5" x 15.5"

**Weight:** 21 kg (46 lb) [without oil]

**Maximum Oil Capacity:** (vented reservoir)  
9.5 L (2.5 Gallons) [to fill line]  
9.4 L (2.5 Gallons) [usable]

**Operating Environment:** -25°C to +50°C  
(-13°F to +122°F)

(When operating near temperature extremes, it is recommended to use hydraulic oils that are rated for those temperatures. Refer to service manuals and cooling options)

**Sound Level:** 85 dBA (max)

**Pressure:** 0 - 1,500 bar (0 - 21,750 psi)

**Typical Flow:** 0.72 L/min - 0.28 L/min  
(44 in<sup>3</sup>/min - 17 in<sup>3</sup>/min)

**Air:** 0.68 m<sup>3</sup>/min @ 5.5 bar (24 cfm @ 80 psi)  
0.74 m<sup>3</sup>/min @ 6.2 bar (26 cfm @ 90 psi)  
0.80 m<sup>3</sup>/min @ 6.9 bar (28 cfm @ 100 psi)

\* Values shown are with filter/regulator/lubricator.  
Values will increase without filter/regulator/  
lubricator.

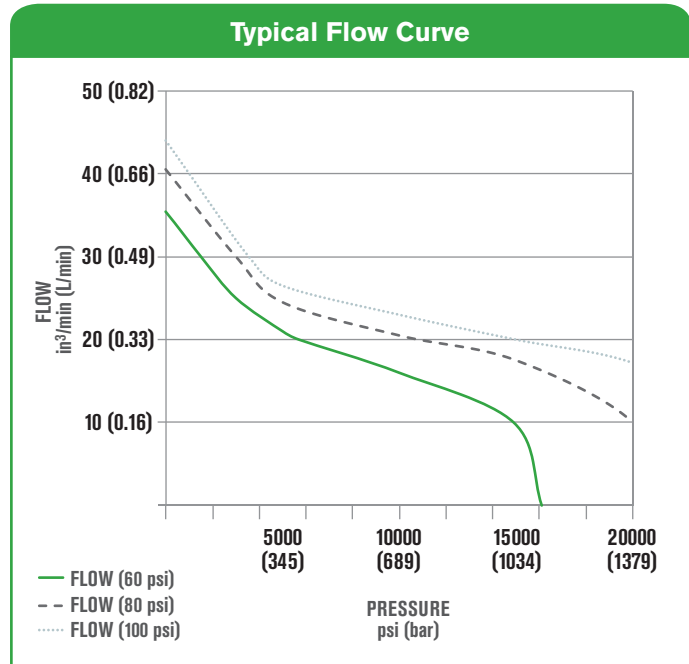

### Hydraulic Oil Delivery

	@ 6.9 bar @ 100 psi	@ 5.5 bar @ 80 psi	@ 4.1 bar @ 60 psi
750 psi (51 bar)	41 in <sup>3</sup> /min (0.67 L/min)	38 in <sup>3</sup> /min (0.62 L/min)	33 in <sup>3</sup> /min (0.54 L/min)
2,500 psi (175 bar)	35 in <sup>3</sup> /min (0.57 L/min)	33 in <sup>3</sup> /min (0.54 L/min)	27 in <sup>3</sup> /min (0.44 L/min)
5,000 psi (350 bar)	27 in <sup>3</sup> /min (0.44 L/min)	25 in <sup>3</sup> /min (0.40 L/min)	21 in <sup>3</sup> /min (0.34 L/min)
10,000 psi (689 bar)	23 in <sup>3</sup> /min (0.38 L/min)	21 in <sup>3</sup> /min (0.34 L/min)	16 in <sup>3</sup> /min (0.26 L/min)
15,000 psi (1,000 bar)	20 in <sup>3</sup> /min (0.33 L/min)	18 in <sup>3</sup> /min (0.29 L/min)	9 in <sup>3</sup> /min (0.15 L/min)
21,750 psi (1,500 bar)	15 in <sup>3</sup> /min (0.24 L/min)	-	-

### Ordering Information

Order No.	Description
<b>HPUTP150001K</b>	1,500 Bar Standard Flow Tensioner Pump

# HIGH FLOW & SUBSEA TENSIONER PUMP

HPUTP-2  
1,500 bar/21,750 psi

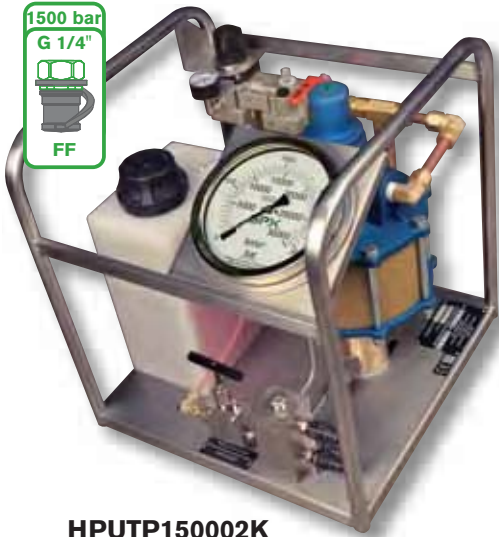

HPUTP150002K

## 1,500 BAR (21,750 PSI) SUBSEA & LARGE TENSIONER APPLICATIONS

High flow tension pump. Corrosion resistant frame works well for applications near salt water. High flow ideal for subsea applications where compressed air is the required power source.

### Quality means Lower Life-Cycle Costs:

- Over 100,000 cycles
- Continuous duty up to 50°C (122°F) ambient
- Proven design = Proven reliability

### Enhanced Usability:

- Calibrated 150 mm (6") Pressure Gauge
- Dual oil outlets with quick-connect, no spill couplings
- Pneumatic Filter/Regulator/Lubricator included
- Stainless Steel carrying frame

### Designed with Safety in Mind:

- Easily adjusted pressure regulator valve
- Air pressure safety relief valve

### DESIGNED FOR



MAINTENANCE & REPAIR

ORIGINAL INSTALL

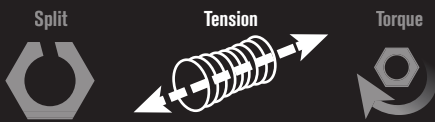

Max Flow



## Specifications and Dimensional Data

**Size (L x W x H):** 46 cm x 53 cm x 52 cm  
17.9" x 20.8" x 15.3"

**Weight:** 23 kg (51 lb) [without oil]

**Maximum Oil Capacity:** (vented reservoir)  
9.5 L (2.5 Gallons) [to fill line]  
9.4 L (x2.5 Gallons) [usable]

**Operating Environment:** -25°C to +50°C  
(-13°F to +122°F)

(When operating near temperature extremes, it is recommended to use hydraulic oils that are rated for those temperatures. Refer to service manuals and cooling options)

**Sound Level:** 85 dBA (max)

**Pressure:** 0 - 1,500 bar (0 - 21,750 psi)

**Typical Flow:** 1.15 L/min - 0.50 L/min  
(70 in<sup>3</sup>/min - 31 in<sup>3</sup>/min)

**Air:** 1.42 m<sup>3</sup>/min @ 5.5 bar (52 cfm @ 80 psi)  
1.53 m<sup>3</sup>/min @ 6.2 bar (54 cfm @ 90 psi)  
1.60 m<sup>3</sup>/min @ 6.9 bar (56 cfm @ 100 psi)

\* Values shown are with filter/regulator/lubricator.  
Values will increase without filter/regulator/  
lubricator.



### Typical Flow Curve

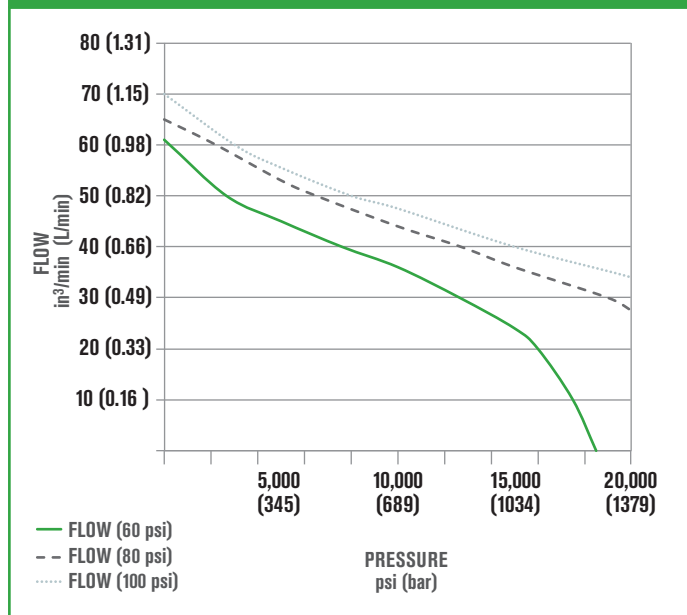

## Hydraulic Oil Delivery

	@ 6.9 bar @ 100 psi	@ 5.5 bar @ 80 psi	@ 4.1 bar @ 60 psi
<b>750 psi (51 bar)</b>	68 in <sup>3</sup> /min (1.11 L/min)	63 in <sup>3</sup> /min (1.04 L/min)	59 in <sup>3</sup> /min (0.97 L/min)
<b>2,500 psi (175 bar)</b>	63 in <sup>3</sup> /min (1.03 L/min)	59 in <sup>3</sup> /min (0.97 L/min)	53 in <sup>3</sup> /min (0.87 L/min)
<b>5,000 psi (350 bar)</b>	56 in <sup>3</sup> /min (0.91 L/min)	53 in <sup>3</sup> /min (0.87 L/min)	45 in <sup>3</sup> /min (0.74 L/min)
<b>10,000 psi (689 bar)</b>	48 in <sup>3</sup> /min (0.78 L/min)	44 in <sup>3</sup> /min (0.72 L/min)	36 in <sup>3</sup> /min (0.59 L/min)
<b>15,000 psi (1,000 bar)</b>	40 in <sup>3</sup> /min (0.66 L/min)	36 in <sup>3</sup> /min (0.59 L/min)	24 in <sup>3</sup> /min (0.39 L/min)
<b>21,750 psi (1,500 bar)</b>	31 in <sup>3</sup> /min (0.51 L/min)	-	-

## Ordering Information

Order No.	Description
<b>HPUTP150002K</b>	1,500 Bar High Flow Tensioner Pump

## HIGH PRESSURE HAND PUMP

1,500 bar/21,750 psi



HPUHP150001

## TWO STAGE, HIGH PRESSURE HAND PUMP

- Two-speed reduces handle strokes so you work faster and easier
- Built-in, protected pressure gauge
- Ergonomic design for minimal handle effort
- Lightweight aluminum reservoir
- Easily accessible refill port
- Needle valve allows full control when releasing tension

### DESIGNED FOR

Electric



Air



Gas



Hand



MAINTENANCE  
& REPAIR

ORIGINAL  
INSTALL

Split



Tension



Torque



Max  
Flow





## Specifications and Dimensional Data

**Size:** (L x W x H): 62 cm x 11 cm x 17 cm  
24.4" x 4.3" x 6.7"

**Weight:** 8.7 kg (19.1 lb) [with oil]

**Maximum Oil Capacity:** (vented reservoir)  
1.1 L (0.29 Gallons) [to fill line]  
1.0 L (0.26 Gallons) [usable]

**Operating Environment:** -25°C to +50°C  
(-13°F to +122°F)

(When operating near temperature extremes, it is recommended to use hydraulic oils that are rated for those temperatures. Refer to service manuals and cooling options)

**Pressure:** 0 - 1,500 bar (0 - 21,750 psi)

**Typical Flow:** 20 cm<sup>3</sup> stroke - 1 cm<sup>3</sup> stroke  
(1.22 in<sup>3</sup>/stroke - 0.061 in<sup>3</sup>/stroke)

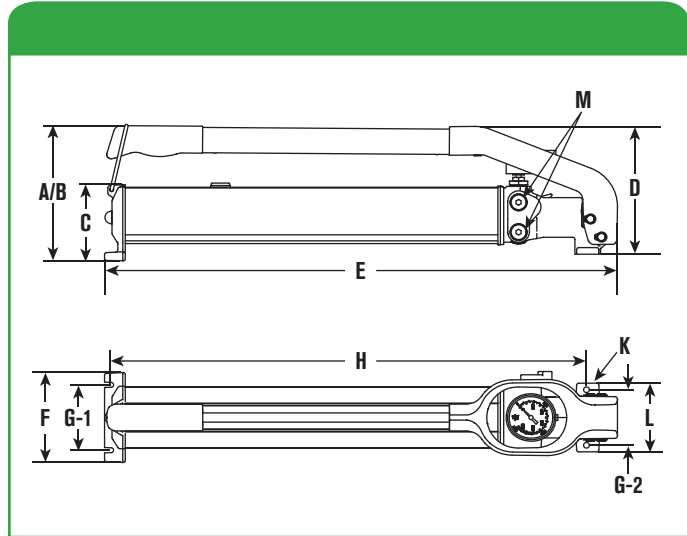





Order No.	A mm in	B mm in	C mm in	D mm in	E mm in	F mm in	G1 mm in	G2 mm in	H mm in	J deg	K mm in	L mm in	M in
HPUHP150001	170	560	152	170	620	110	80	68	575	55	6.6	84	61/4"
	6.69	22	6	6.69	24.41	4.33	3.15	2.68	22.64	55	0.26	3.31	61/4"

## Ordering Information

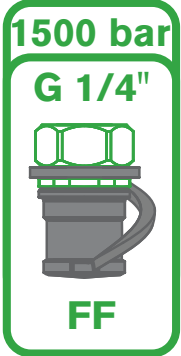
For use with	Order No	Speed	Volume per Stroke		Maximum Pressure		Handle Effort	Oil Capacity	Usable Oil Capacity	Oil Port	Product Weight
			LP in <sup>3</sup> cm <sup>3</sup>	HP in <sup>3</sup> cm <sup>3</sup>	LP psi bar	HP psi bar					
Tensioners	HPUHP150001	2	1.22	0.061	290	21750	83	61	61	61/4"	19.1
			20	1	20	1,500	370	1	1	61/4"	8.7

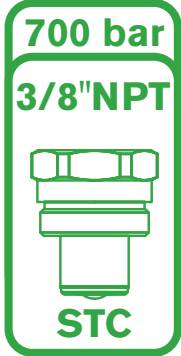
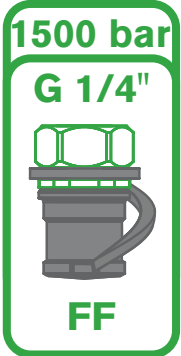
## Coupler Explanation

	1,500 BAR 21750 PSI	700 BAR 10000 PSI	
	TENSIONERS	TORQUE WRENCHES ENS SPLITTER	OTHER TOOLS
TOPSIDE	 <p>1500 bar G 1/4" FF</p>	 <p>700 bar 1/4"NPT STC</p>	 <p>700 bar 3/8"NPT STC</p>
SUBSEA	 <p>1500 bar G 1/4" FF</p>	 <p>700 bar 1/4"NPT FF</p>	

Male FF couplers can connect to recessed style (standard) couplers and Flat Face (optional) couplers. Contact factory for information about Flat Face coupler options.

### Coupler Icon Explanation

### No Coupler Included

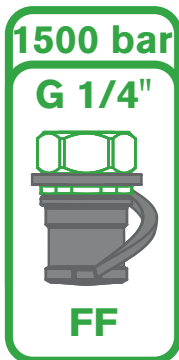

#### RATED PRESSURE

700 bar (10,000 psi) or 1,500 bar (21,750 psi)

#### THREAD TYPE

1/4" NPT or 3/8" NPT or G 1/4"

#### ICON

#### COUPLER TYPE

STC = Screw to Connect or FF = Flat Face

Some products do not include couplers. Couplers need to be ordered separately.



# ACCESSORIES

Page  
**TOPSIDE TORQUE  
WRENCH...100**

Hoses, Couplers, and  
Accessories



Page  
**HYDRAULIC  
FLUIDS...105**

Standard  
Flame Out  
Biodegradable  
Low Temperature



Page  
**TOPSIDE  
TENSION...101**

Hoses, Couplers, and  
Accessories



Page  
**FLANGE MANAGEMENT  
SYSTEMS...106**

Flangepro



Page  
**SUBSEA TORQUE  
WRENCH...102**

Hoses, Couplers, and  
Accessories



Page  
**BOLT LOAD  
CALCULATOR...107**

Advisor



Page  
**SUBSEA  
TENSION...103**

Hoses, Couplers, and  
Accessories



Page  
**TRAINING...108-109**

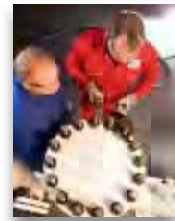

Page  
**SPLITTERS &  
SPREADERS...104**

Hoses, Couplers, and  
Accessories



Page  
**RENTAL...110-111**



# TOPSIDE TORQUE WRENCH

1/4" COUPLERS  
700 bar/10,000 psi



## Twin-line Topside Hoses

Standard IJ100 Twin-line Hoses (2:1 Burst)	
Order No.	DESCRIPTION
TWH15-BS	15 ft twin-line hose
TWH20-BS	20 ft twin-line hose
TWH50-BS	50 ft twin-line hose

Standard CE Twin-line Hoses (4:1 Burst)	
Order No.	DESCRIPTION
TWH3E	3 meter twin-line hose
TWH6E	6 meter twin-line hose
TWH10E	10 meter twin-line hose

Additional lengths (all styles) available upon request.

9072		700 bar, 10,000 psi gauge for torque wrench applications
252365		Metal Dust Cover for male coupler
252364		Metal Dust Cover for female coupler
(male) 251411		Quick-connect, screw-on male nipple. Used on 700 bar torque wrenches, nutsplitters, hoses, and pumps. 1/4" NPT Female Thread
(female) 251410		Quick-connect, screw-on female coupling. Used on 700 bar torque wrenches, nutsplitters, hoses, and pumps. 1/4" NPT Female Thread



## Tensioner Hoses

Order No.	Topside, with Locking Collar DESCRIPTION
HL1M-LC	1 m Hose, 1,500 bar, with locking collar (only stocked in Europe & Asia)
HL13M-LC	1.3 m Hose, 1,500 bar, with locking collar (Optionally available in the Americas)
HL3M-LC	3 m Hose, 1,500 bar, with locking collar
HL5M-LC	5 m Hose, 1,500 bar, with locking collar
HL8M-LC	8 m Hose, 1,500 bar, with locking collar
HL10M-LC	10 m Hose, 1,500 bar, with locking collar

For hoses without locking collars, remove "-LC" from the part number. In the Americas, the 1.3 m hose is typically stocked without a locking collar (No. HL13M). Hoses with locking collars are available upon request (No. HL13M-LC).

Additional lengths available upon request.

## TOPSIDE TENSION

1,500 bar/21,750 psi



2002278		2,000 bar; 30,000 psi gauge for PE8 pumps. Typically attached with quick coupler (ordered separately).
HHAMA150001		<b>1,500 Bar Elbow Block:</b> Used to change direction of tensioner hoses if standard orientation is not possible. Hoses can swivel around coupling axis.
HHAMA150003		<b>1,500 Bar Tee Block Assembly:</b> Used to interconnect tensioners with single ports.
HHAMA150004		<b>1,500 Bar Banjo Assembly:</b> Used to allow a hose to connect to a tool at 90 degrees. The nipple can be oriented in any direction around the port axis but must be tightened to create a seal. <b>Does not act as a swivel</b> around port axis.

2001772		<b>Male Coupling:</b> Quick-connect, push-in male nipple. Used on 1,500 bar tensioners and pumps. G 1/4" Female Thread
2008547		<b>Female Coupling:</b> Quick-connect, push-in female coupling with locking collar. Used on 1,500 bar tensioner hoses. G 1/4" Female Thread.
STDHC000025		<b>1/4" BSP Plug:</b> Used to plug a port when a banjo assembly or coupling will not be used.

Hoses come standard with recessed female coupler type (2008547). Flat Face couplers available upon request.

**SUBSEA  
TORQUE WRENCH  
1/4" COUPLERS  
700 bar/10,000 psi**

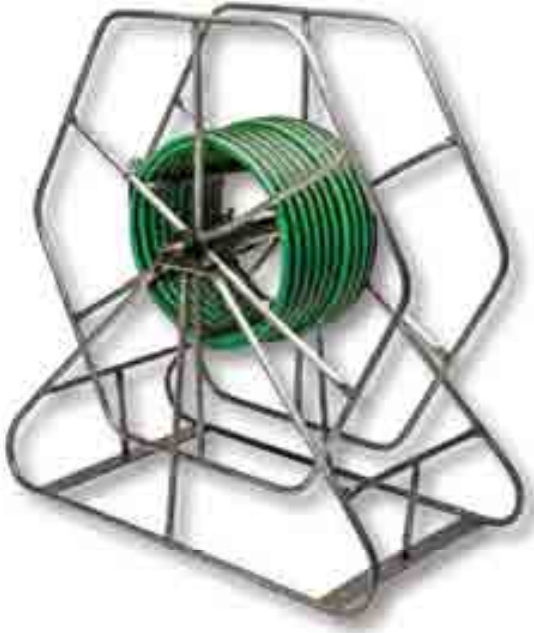

**SUBSEA TWIN-LINE HOSES**

SPX can customize a reel and hose combination for your specific job. Standard reel construction is powder coated carbon steel. Aluminum reels optional. Contact factory for details.



**Twin-line Subsea Hoses**

Standard CE Twin-line Subsea Hoses (4:1 Burst)	
Order No.	DESCRIPTION
TWH06E-SS	6 meter (20 ft) twin-line subsea hose, uses red couplers shown below (2008549 & 2008550)
Standard IJ100 Twin-line Hoses (2:1 Burst)	
Order No.	DESCRIPTION
	6 meter (20 ft) twin-line subsea hose, uses red couplers shown below (2008549 & 2008550)



Additional lengths (all styles) available upon request.

9072		700 bar, 10,000 psi gauge for torque wrench applications
------	---	--

Couplers for hose reel and offshore equipment.

(male) 251411		Quick-connect, screw-on male nipple. Used on 700 bar torque wrenches, nutsplitters, hoses, and pumps. 1/4" NPT Female Thread
(female) 251410		Quick-connect, screw-on female coupling. Used on 700 bar torque wrenches, nutsplitters, hoses, and pumps. 1/4" NPT Female Thread

Couplers for Diver Control Valve and select subsea tools.

(male) 2008549		Quick-connect, push-in male nipple. Used on Subsea 700 bar torque wrenches, nutsplitters, flange pullers, hoses, and pumps. 1/4" NPT Female Thread
(female) 2008550		Quick-connect, push-in female coupling with locking collar. Used on 700 bar torque wrenches, nutsplitters, flange pullers, hoses, and pumps. 1/4" NPT Female Thread

Remote Diver Control Valve (HCUCV070001) uses 1 each of all four couplings shown on this page.

## SUBSEA TENSION HOSES

SPX can customize a reel and hose combination for your specific job. Standard reel construction is powder coated carbon steel. Stainless hose reels optional. Contact factory for details.

Downline hoses usually supplied in 30 m lengths, male / female quick connect couplings so they can be linked together to make up the desired length of hose.

Maximum hose length capacity 500 m

## SUBSEA TENSION



1,500 bar/21,750 psi



### Subsea Tensioner Hoses

Subsea, without Locking Collar	
Order No.	DESCRIPTION
HL1M	1 m Hose, 1,500 bar, without locking collar (only stocked in Europe & Asia)
HL13M	1.3 m Hose, 1,500 bar, without locking collar (only stocked in the Americas)
HL3M	3 m Hose, 1,500 bar, without locking collar
HL5M	5 m Hose, 1,500 bar, without locking collar
HL8M	8 m Hose, 1,500 bar, without locking collar
HL10M	10 m Hose, 1,500 bar, without locking collar
Subsea down-line hose	
Order No.	DESCRIPTION
HL30M-DL	30 m Hose, 1500 bar, with locking collar, 1 x male + 1 x female coupler with locking collar. Used to link hoses together between hose reel and subsea work site.

Additional lengths available upon request.

HPSTP150004		2,000 bar; 30,000 psi gauge for HPUTP pumps
HHAMA15002		<b>1,500 Bar 3-Port Manifold Assembly:</b> Used in Subsea hose arrangement to split single downline into two hoses which connect to the first two tensioners in the circuit. Can also be used to split a single feed hose to feed 2 tensioners.

2008548		<b>Female Coupling:</b> Quick-connect, push-in female coupling without locking collar. Used on 1,500 bar Subsea tensioner hoses. 6 1/4" Female Thread
2001772		<b>Male Coupling:</b> Quick-connect, push-in male nipple. Used on 1,500 bar tensioners and pumps. 6 1/4" Female Thread

Hoses come standard with recessed female coupler type (2008548). Flat Face couplers available upon request.

## SPLITTERS & SPREADERS

### 3/8" COUPLERS

700 bar/10,000 psi



9764

## IJ100 HYDRAULIC HOSE ASSEMBLY (AMERICAS & ASIA)

**No. 9764** – Hose assembly consisting of 9767 (6' hose), 1/4" I.D. polyurethane with 9798 hose half coupler and 9800 dust cap assembly. Complies to MHI Standard IJ100 (2:1 Burst).

## CE HYDRAULIC HOSE ASSEMBLY (EUROPE)

**No. 9764E** – Hose assembly consisting of 9767E (2m hose), 6mm I.D. polyurethane with 9798 hose half coupler and 9800 dust cap assembly. Complies to CE Standards (4:1 Burst over Nominal pressure ratio).

9040 9040E		Gauge for 700 bar; 10,000 psi hand pumps. 9040 has psi as primary unit. 9040E has bar as primary unit.
9670		Tee adapter. For installing gauge between pump and hose coupling. Has 1/4" and 3/8" NPTF female and 3/8" NPTF male ports.
9799		Optional metal dust cap (hose half)
9797		Optional metal dust cap (pump/tool half)
9798 (male coupler)		Male (hose) half coupler (less No. 9800 dust cap). 3/8" NPTF.
9796 (female coupler)		Female (pump/tool) half coupler (with No. 9800 dust cap). 3/8" NPTF.
9800		Dust cap for male or female 3/8" NPTF half couplers.

Not for EHN Nut Splitter. For topside EHN, see page 100. For Subsea EHN, see page 102.



## STANDARD HYDRAULIC OIL

- For dependable performance of all your hydraulic pumps and cylinders.
- Contains foam suppressant additives and has a high viscosity index.

## FLAME-OUT® 220 FIRE RESISTANT HYDRAULIC FLUID\*

- Contains anti-rust, anti-foam and anti-sludge additives.
- Provides fire resistant protection.

**(Note: Will burn if heat source is extreme enough. Will not, however, propagate the flame and is self-extinguishing when there is no ignition source.)**

- Provides maximum lubrication and heat transfer.
- Offers a wider operating temperature range.
- No need to change seals in your equipment. Just drain the standard oil and replace it with Flame-Out® 220.

## LOW TEMPERATURE OIL

Provides smooth, reliable operation in the coldest climate conditions.

## HYDRAULIC FLUIDS

Standard, Flame Out®, Biodegradable and Low Temperature

## BIODEGRADABLE HYDRAULIC FLUID

- Biodegradable, non-toxic fluid withstands moderate to severe operating conditions; provides excellent protection against rust.
- Offers superior anti-wear properties, has excellent multi-metal compatibility.

Developed to meet stringent performance requirements and satisfy growing environmental needs for hydraulic fluids which are readily biodegradable and non-toxic. Depending on the contamination or degradation levels which might be present in used fluid, small amounts of this substance, if spilled, will not affect ground water or the environment. This fluid has been tested against EPA 560/6-82-003 and OECD 301 for biodegradability, and toxicity has been tested against EPA 560/6-82-002 and OECD 203: 1-12. Not recommended for operation in temperatures below 20°F (-7°C) or above 160°F (71°C). Recommended storage temperatures not below -10°F (-23°C) or above 170°F (77°C).

### Specifications and Dimensional Data

Description	Grade (ASTM)	Specific Gravity @ 60°F (16°C)	Color (ASTM)	Flash Point		Fire Point		Pour Point		Viscosity			Foam Test (ASTM)
				°F	°C	°F	°C	°F	°C	SUS @ 100°F (38°C)	SUS @ 210°F (99°C)	Index min.	
Standard Oil	215	.88	2.0	400	204	430	221	-30	-34	215	48	100	Pass
Flame-Out®	220	.91	Light Amber	500	260	550	288	-15	-26	220	55	140	Pass
Biodegradable	—	.92	2.0	432	224	NA*	NA*	-22	30	183	53	213	Pass
Low Temp.	—	.87	6.5 (Red)	356	180	399	204	-48	45	183	52	190	Pass

### Ordering Information

Order No.	Description	Quantity
9636	Standard Oil	1 qt. (57 cu. in.) 0.9l
9637	Standard Oil	1 gal. (231 cu. in.) 3.8l
9638	Standard Oil	2-1/2 gal. (577 cu. in.) 9.5l
9616	Standard Oil	55 gal. 208l
9639	Flame-Out®	1 gal. (231 cu. in.) 3.8l
9640	Flame-Out®	2-1/2 gal. (577 cu. in.) 9.5l
9645	Biodegradable	1 gal. (231 cu. in.) 3.8l
9646	Biodegradable	2-1/2 gal. (577 cu. in.) 9.5l
9647	Low Temp.	1 gal. (231 cu. in.) 3.8l



For additional technical information or to order a Material Safety Data Sheet call 1-800-477-8326 or go to [www.boltingsystems.com](http://www.boltingsystems.com).

# FLANGE MANAGEMENT SYSTEMS

## FLANGEPRO

### FLANGEPRO

FlangePro provides a fully featured Flange Management System, maximizing the control of the flange register, allowing comprehensive and consistent operation of all flange break, make-up and inspection processes for commissioning, operations and turnarounds/shutdown applications.

Built upon our unique and highly flexible Integrity Management System platform, FlangePro can be used in many different fields, project phases (Pre-Bid, On Site Work, Pre-Work and Completion Handover) and for many different service lines and activities, such as;

- Flange Management
- Equipment & Inventory Management
- Personnel management
- Service, Inspection and Process Management
- Shutdown Project Management
- Pre-Commissioning Completions Management
- Leak Test planning



#### Product Features:

- Multiple Projects
- Secure Cloud Platform
- Asset Identification
- Configurability / Flexibility
- Markup tool

Visit [spxboltingsystems.com](http://spxboltingsystems.com) for more details



Sort workpacks/activities by status for ease of management

Visual workflow status matching any tagging process adopted

Full history of workflow/activities is recorded against the safety critical artifact and the activity pack it is held on.

## ADVISER BOLT LOAD CALCULATOR

The adviser software considers many years of bolt working experience, where data has been channeled into a single computer software program. Bolt tightening data, procedures and recommendations for standard, non-standard and specialty joints makes adviser an invaluable tool to any industry.

The Adviser software package includes:

- Tightening data for BS1560, MSS SP44, API 6A and 17D flanged joints.
- Encompasses standard flanges, wafer check valves, spade and spacers, and swivel flange assemblies.
- Torque data and tensioning tool pressures for both Subsea and Topsides applications.
- Bolt extension calculations.
- Tightening procedures and Torque sequences.
- Joint specific recommendations for improved integrity.
- Large database of bolt materials.
- Large database of bolt lubricants.
- Dimensional data of flanges.
- Recommended bolt lengths.
- Simple user interface with 'Windows' look and feel.
- New bolt materials and lubricants can be added!

## BOLT LOAD CALCULATOR ADVISOR

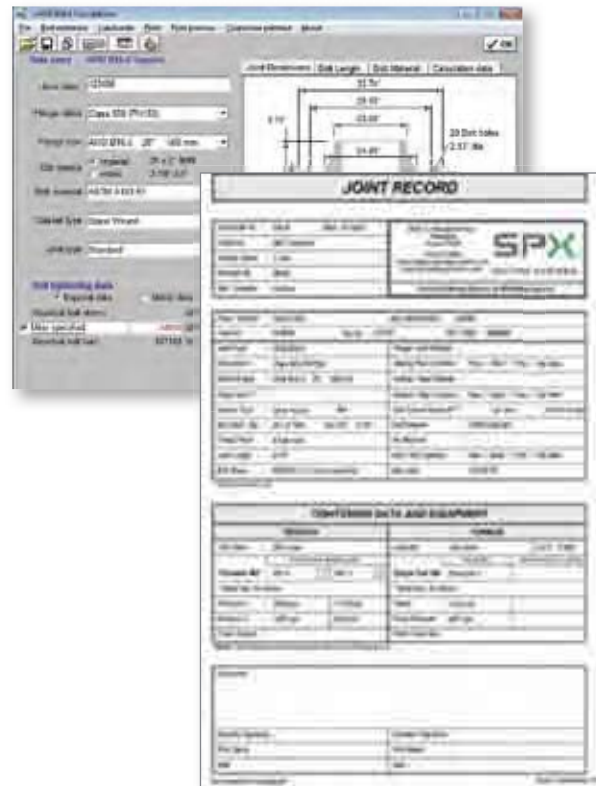

Visit the Apple AppStore for mobile applications



## TRAINING



SPX Bolting Systems offer a range of courses covering joint integrity and flange management to industry recognized standards. All of our instructors have many years' experience in the joint integrity/flange management sector most of which have spent considerable time in a hands on role actually doing the job that they are now training others to do. Our instructors have nationally recognized teaching qualifications which reinforce the quality of the training programs that we offer.

Our courses contain a mix of both theoretical and practical elements providing a positive learning experience for the learner. We have purpose built training facilities around the globe which house the latest in flange management tooling and associated equipment and in which learners are encouraged by our Instructors to embrace all aspects of Health and Safety and to strive for a right first time approach to all joint integrity

applications. Courses can be delivered in a variety of formats including:

- Industry Approved training
- Well established in-house programs
- Bespoke options tailored to a client's requirements, such as ASME PCC-1-2013

SPX Bolting Systems are an ECITB and API approved training provider.



Engineering Construction Industry Training Board

APPROVED PROVIDER

### ECITB APPROVED TRAINING

The ECITB has approved four specific courses which are derived from the new Technical Training Standards MJ10, 18 & 19.

- MJ10 - Hand Torque Bolted Connection Techniques – one day duration
- MJ18 - Hydraulically Tension Bolted Connection Techniques – one day duration
- MJ19 - Hydraulically Torque Bolted Connection Techniques – 1.5 days duration
- MJ10, 18 & 19 - Hydraulically Torque and Tension Bolted Connection Techniques – 2.5 days duration

### TECHNICAL TESTS

Technical Testing with an associated ECITB certificate of achievement plays a key role in validating an individual's skill, ability and job knowledge in a specific task area. Each test consists of a knowledge test and practical activity test against identified test criteria.

- There are five ECITB approved Technical Tests covering mechanical joint integrity.
- TMJI10 Dismantle, Assemble and Hand Torque Flanged Joints
- TMJI11 Dismantle, Assemble and Hand Torque Clamp Connectors

- TMJI18 Dismantle, Assemble and Tensioning Bolted Connections (Hydraulic Tensioning)
- TMJI 19 Dismantle, Assemble and Hydraulically Torque Flanged Joints
- TMJI 20 Dismantle, Assemble and Hydraulically Torque Clamp Connector Joints

### ECITB courses and technical tests can be delivered at:

- SPX UK ECITB approved training and testing centers
- SPX Houston, TX, USA ECITB approved training and testing centers
- SPX Global Training facilities – subject to approval via SPX Training UK and ECITB
- Client Site UK – subject to approval via SPX Training UK.
- Client Site Global - subject to approval via SPX Training UK and ECITB





## AMERICAN PETROLEUM INSTITUTE - APPROVED TRAINING

As an API-U approved training provider SPX can offer a two day course covering the assembly, tightening and disassembly of bolted connections. This course includes in depth practical instruction on the safe and effective use of both hand and hydraulic bolt tightening equipment.

### This SPX API approved training course can be delivered at:

- SPX global training facilities
- Client Site Global – subject to approval via SPX Training UK.

API-U is dedicated to providing excellence in petroleum industry training. Because API has access to the largest pool of subject experts in the industry, API-U programs are taught by the best trainers who utilize today's innovative methods. The practical knowledge gained from API-U training enables participants to maintain professional competency.



## ADDITIONAL COURSE OFFERINGS

SPX ADVISOR – controlled bolting software  
 SPX FLANGEPRO – joint monitoring software

Service and Maintenance of SPX products



IOSH Managing Safely  
 IOSH Working Safely

Manual Handling

Level 2 Award in Emergency First Aid at Work - UK

Level 3 Award in First Aid at Work – UK

Level 2 Award in Paediatric First Aid – UK

Level 2 Award in CPR and AED - UK



## RENTAL, CALIBRATION & SERVICE CENTERS

SPX Rental Service Centers offer full range of hydraulic torque wrenches, topside tensioners, subsea tensioners, nut splitters, pump units and ancillary equipment all available 24/7 to meet our customers needs.





## HOUSTON, TEXAS

- Located in Pasadena, TX near the O&G, Refinery and Petrochemical market
- Full Rental Inventory
- Training Facilities
- Calibration
- Repair
- 24/7 Availability



## ABERDEEN, SCOTLAND

- Near key North Sea Offshore customers
- Rental Inventory
- Training Facilities



## PERTH, AUSTRALIA

- Serves SE Asia customers
- Rental Inventory
- Training Facilities



## OTHER LOCATIONS

- Ashington, UK (Center of Excellence)
- Egelshoven, Netherlands
- Singapore



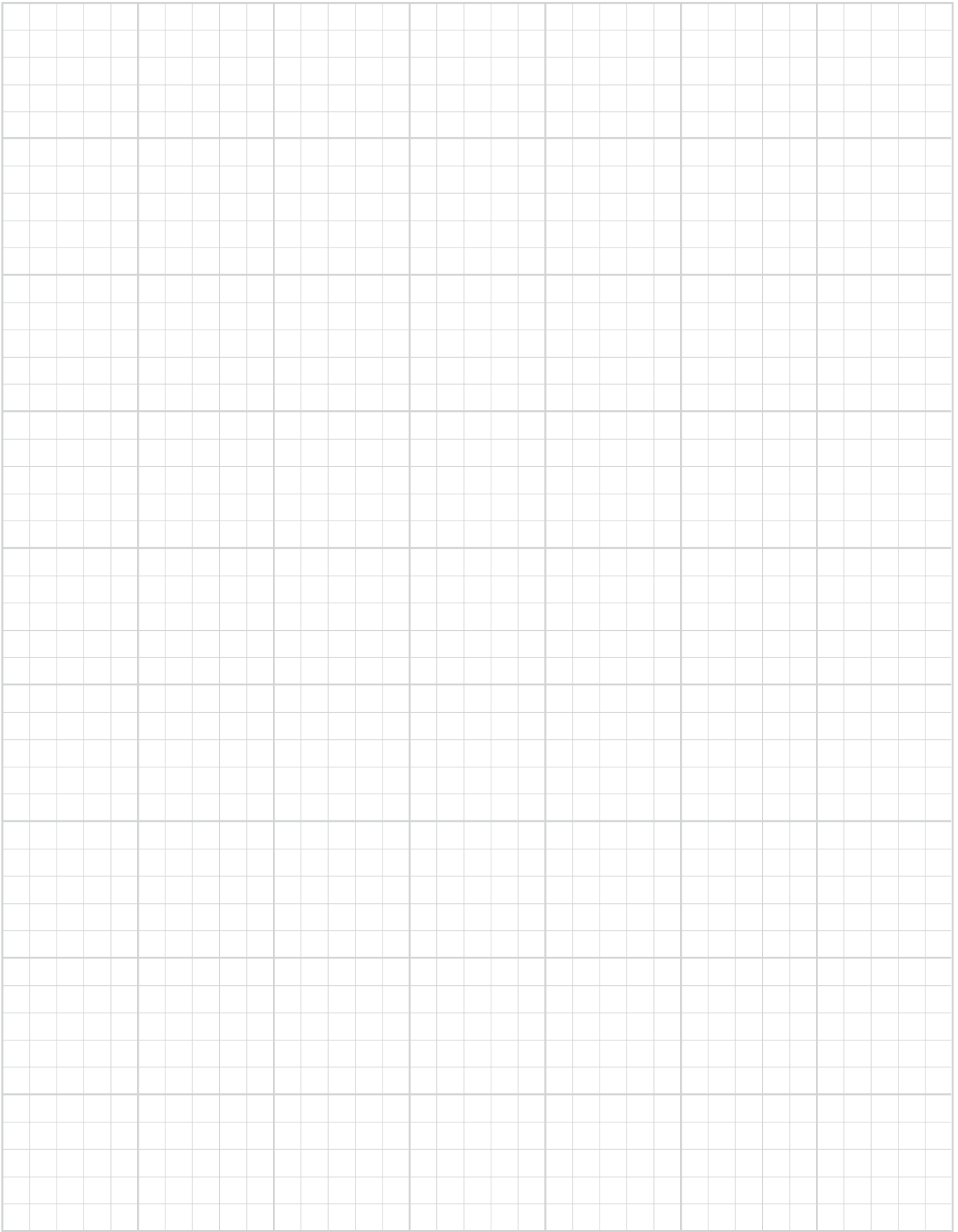



# RESOURCES



Page  
**MEASUREMENTS/  
SPECIFICATIONS...114-121**  
Conversion Formulas  
Reference Tables



Page  
**SPX BOLT TENSIONERS...122-123**  
How it works

Page  
**HYDRAULIC BOLTING SAFETY...124-125**



Page  
**APPLICATION DATA SHEET...126**

Page  
**MANUFACTURING STANDARDS...128**

Page  
**POWERTHON™ LIFETIME WARRANTY...129**



Page  
**CUSTOM PRODUCTS...130-131**



# MEASUREMENTS / SPECIFICATIONS

## Conversion Formulas

### Decimal & Millimeter Equivalents

	DECIMALS	MILLIMETERS		DECIMALS	MILLIMETERS
1/64	.015625	0.397	33/64	.515625	13.097
1/32	.03125	0.794	17/32	.53125	13.494
3/64	.046875	1.191	35/64	.546875	13.891
1/16	.0625	1.588	9/16	.5625	14.288
5/64	.078125	1.984	37/64	.578125	14.684
3/32	.09375	2.381	19/32	.59375	15.081
7/64	.109375	2.778	39/64	.609375	15.478
1/8	.1250	3.175	5/8	.6250	15.875
9/64	.140625	3.572	41/64	.640625	16.272
5/32	.15625	3.969	21/32	.65625	16.669
11/64	.171875	4.366	43/64	.671875	17.066
3/16	.1875	4.763	11/16	.6875	17.463
13/64	.203125	5.159	45/64	.703125	17.859
7/32	.21875	5.556	23/32	.71875	18.256
15/64	.234375	5.953	47/64	.734375	18.653
1/4	.2500	6.350	3/4	.7500	19.050
17/64	.265625	6.747	49/64	.765625	19.447
9/32	.28125	7.144	25/32	.78125	19.844
19/64	.296875	7.541	51/64	.796875	20.241
5/16	.3125	7.938	13/16	.8125	20.638
21/64	.328125	8.334	53/64	.828125	21.034
11/32	.34375	8.731	27/32	.84375	21.431
23/64	.359375	9.128	55/64	.859375	21.828
3/8	.3750	9.525	7/8	.8750	22.225
25/64	.390625	9.922	57/64	.890625	22.622
13/32	.40625	10.319	29/32	.90625	23.019
27/64	.421875	10.716	59/64	.921875	23.416
7/16	.4375	11.113	15/16	.9375	23.813
29/64	.453125	11.509	61/64	.953125	24.209
15/32	.46875	11.906	31/32	.96875	24.606
31/64	.484375	12.303	63/64	.984375	25.003
1/2	.5000	12.700	1	1.000	25.400

1 mm = .03937"  
 .001" = .0254 mm



## SI\* Conversion Formulas

### APPROXIMATE CONVERSION

MULTIPLY SI* UNIT	BY CONVERSION FACTOR	TO GET OR MULTIPLY NON-SI UNIT	BY CONVERSION FACTOR	TO GET SI* UNIT
<b>LENGTH</b>				
millimeter (mm)	X 0.03937	= inch	X 25.4	= mm (1 inch = 25.4 mm exactly)
centimeter (cm) 10 mm	X 0.3937	= inch	X 2.54	= cm
meter (m) 1000 mm	X 3.28	= foot	X 0.305	= m
meter (m)	X 1.09	= yard	X 0.914	= m
kilometer (km) 1000 m	X 0.62	= mile	X 1.61	= km
<b>AREA</b>				
millimeter <sup>2</sup> (mm <sup>2</sup> )	X 0.00155	= inch <sup>2</sup>	X 645	= mm <sup>2</sup>
centimeter <sup>2</sup> (cm <sup>2</sup> )	X 0.155	= inch <sup>2</sup>	X 6.45	= cm <sup>2</sup>
meter <sup>2</sup> (m <sup>2</sup> )	X 10.8	= foot <sup>2</sup>	X 0.0929	= m <sup>2</sup>
meter <sup>2</sup> (m <sup>2</sup> )	X 1.2	= yard <sup>2</sup>	X 0.836	= m <sup>2</sup>
hectare (ha) 10,000 m <sup>2</sup>	X 2.47	= acre	X 0.405	= ha
kilometer <sup>2</sup> (km <sup>2</sup> )	X 0.39	= mile <sup>2</sup>	X 2.59	= km <sup>2</sup>
<b>VOLUME</b>				
centimeter <sup>3</sup> (cm <sup>3</sup> )	X 0.061	= inch <sup>3</sup>	X 16.4	= cm <sup>3</sup>
liter (L)	X 61	= inch <sup>3</sup>	X 0.016	= L
milliliter (mL)	X 0.034	= oz-liq	X 29.6	= mL (1 mL = 1 cm <sup>3</sup> )
liter (L) 1000 mL	X 1.06	= quart	X 0.946	= L
liter (L)	X 0.26	= gallon	X 3.79	= L
meter <sup>3</sup> (m <sup>3</sup> ) 1000 L	X 1.3	= yard <sup>3</sup>	X 0.76	= m <sup>3</sup>
<b>MASS</b>				
gram (g)	X 0.035	= ounce	X 28.3	= g
kilogram (kg) 1000 g	X 2.2	= pound	X 0.454	= kg
metric ton (t) 1000 kg	X 1.1	= ton (short)	X 0.907	= t
<b>FORCE (N = kg • m/s<sup>2</sup>)</b>				
newton (N)	X 0.225	= pound	X 4.45	= N
kilonewton (kN)	X 225	= pound	X 0.00445	= kN
<b>TORQUE</b>				
newton meter (Nm)	X 8.9	= lb. in.	X 0.113	= Nm
newton meter (Nm)	X 0.74	= lb. ft.	X 1.36	= Nm
<b>PRESSURE (Pa = N/m<sup>2</sup>)</b>				
kilopascal (kPa)	X 4.0	= in. H <sub>2</sub> O	X 0.249	= kPa
kilopascal (kPa)	X 0.30	= in. Hg	X 3.38	= kPa
kilopascal (kPa)	X 0.145	= psi	X 6.89	= kPa
megapascal (MPa)	X 145	= psi	X 0.00689	= MPa
bar	X 14.5	= psi	X 0.0680	= bar
<b>POWER (w = J/s)</b>				
kilowatt (kw)	X 1.34	= hp	X 0.746	= kw
kilowatt (kw)	X 0.948	= Btu/s	X 1.055	= kw
watt (w)	X 0.74	= ft. lb/s	X 1.36	= w
<b>TEMPERATURE</b>				
$^{\circ}\text{C} = (^{\circ}\text{F} - 32) \div 1.8$ $^{\circ}\text{F} = (^{\circ}\text{C} \times 1.8) + 32$				
<b>FLOW</b>				
cu cm/min	X 0.061	= cu in/min	X 16.4	= cu cm/min
liters/min	X 0.2642	= GPM	X 3.785	= liters/min

\* System International (Modern Metric System)

# MEASUREMENTS / SPECIFICATIONS

## Conversion Formulas

### TWSD Square Drive Hydraulic Torque Wrench Pressure - Torque Conversion Chart

Pump Pressure		Torque Output									
		TWSD1		TWSD3		TWSD6		TWSD11		TWSD25	
PSI	BAR	lbf.ft.	Nm	lbf.ft.	Nm	lbf.ft.	Nm	lbf.ft.	Nm	lbf.ft.	Nm
1,200	83	156	211	368	499	722	979	1,313	1,779	2,940	3,984
1,400	97	182	247	430	582	843	1,142	1,532	2,075	3,430	4,648
1,600	110	208	282	491	666	963	1,305	1,750	2,372	3,920	5,312
1,800	124	234	317	553	749	1,084	1,468	1,969	2,668	4,410	5,976
2,000	138	260	352	614	832	1,204	1,631	2,188	2,965	4,900	6,640
2,200	152	286	388	675	915	1,324	1,795	2,407	3,261	5,390	7,304
2,400	165	312	423	737	998	1,445	1,958	2,626	3,558	5,880	7,967
2,600	179	338	458	798	1,082	1,565	2,121	2,844	3,854	6,370	8,631
2,800	193	364	493	860	1,165	1,686	2,284	3,063	4,151	6,860	9,295
3,000	207	390	528	921	1,248	1,806	2,447	3,282	4,447	7,350	9,959
3,200	221	416	564	982	1,331	1,926	2,610	3,501	4,744	7,840	10,623
3,400	234	442	599	1,044	1,414	2,047	2,773	3,720	5,040	8,330	11,287
3,600	248	468	634	1,105	1,498	2,167	2,937	3,938	5,337	8,820	11,951
3,800	262	494	669	1,167	1,581	2,288	3,100	4,157	5,633	9,310	12,615
4,000	276	520	705	1,228	1,664	2,408	3,263	4,376	5,930	9,800	13,279
4,200	290	546	740	1,289	1,747	2,528	3,426	4,595	6,226	10,290	13,943
4,400	303	572	775	1,351	1,830	2,649	3,589	4,814	6,522	10,780	14,607
4,600	317	598	810	1,412	1,914	2,769	3,752	5,032	6,819	11,270	15,271
4,800	331	624	846	1,474	1,997	2,890	3,915	5,251	7,115	11,760	15,935
5,000	345	650	881	1,535	2,080	3,010	4,079	5,470	7,412	12,250	16,599
5,200	359	676	916	1,596	2,163	3,130	4,242	5,689	7,708	12,740	17,263
5,400	372	702	951	1,658	2,246	3,251	4,405	5,908	8,005	13,230	17,927
5,600	386	728	986	1,719	2,330	3,371	4,568	6,126	8,301	13,720	18,591
5,800	400	754	1,022	1,781	2,413	3,492	4,731	6,345	8,598	14,210	19,255
6,000	414	780	1,057	1,842	2,496	3,612	4,894	6,564	8,894	14,700	19,919
6,200	427	806	1,092	1,903	2,579	3,732	5,057	6,783	9,191	15,190	20,583
6,400	441	832	1,127	1,965	2,662	3,853	5,221	7,002	9,487	15,680	21,247
6,600	455	858	1,163	2,026	2,746	3,973	5,384	7,220	9,784	16,170	21,911
6,800	469	884	1,198	2,088	2,829	4,094	5,547	7,439	10,080	16,660	22,575
7,000	483	910	1,233	2,149	2,912	4,214	5,710	7,658	10,377	17,150	23,238
7,200	496	936	1,268	2,210	2,995	4,334	5,873	7,877	10,673	17,640	23,902
7,400	510	962	1,304	2,272	3,078	4,455	6,036	8,096	10,970	18,130	24,566
7,600	524	988	1,339	2,333	3,162	4,575	6,199	8,314	11,266	18,620	25,230
7,800	538	1,014	1,374	2,395	3,245	4,696	6,363	8,533	11,563	19,110	25,894
8,000	552	1,040	1,409	2,456	3,328	4,816	6,526	8,752	11,859	19,600	26,558
8,200	565	1,066	1,444	2,517	3,411	4,936	6,689	8,971	12,156	20,090	27,222
8,400	579	1,092	1,480	2,579	3,494	5,057	6,852	9,190	12,452	20,580	27,886
8,600	593	1,118	1,515	2,640	3,578	5,177	7,015	9,408	12,749	21,070	28,550
8,800	607	1,144	1,550	2,702	3,661	5,298	7,178	9,627	13,045	21,560	29,214
9,000	621	1,170	1,585	2,763	3,744	5,418	7,341	9,846	13,341	22,050	29,878
9,200	634	1,196	1,621	2,824	3,827	5,538	7,505	10,065	13,638	22,540	30,542
9,400	648	1,222	1,656	2,886	3,910	5,659	7,668	10,284	13,934	23,030	31,206
9,600	662	1,248	1,691	2,947	3,993	5,779	7,831	10,502	14,231	23,520	31,870
9,800	676	1,274	1,726	3,009	4,077	5,900	7,994	10,721	14,527	24,010	32,534
10,000	689	1,300	1,762	3,070	4,160	6,020	8,157	10,940	14,824	24,500	33,198

# MEASUREMENTS / SPECIFICATIONS

## Conversion Formulas

### TWLC Low Clearance Hydraulic Torque Wrench Pressure - Torque Conversion Chart

Pump Pressure		Torque Output									
		TWLC2		TWLC4		TWLC8		TWLC15		TWLC30	
PSI	BAR	lbf.ft.	Nm	lbf.ft.	Nm	lbf.ft.	Nm	lbf.ft.	Nm	lbf.ft.	Nm
1,200	83	189	256	477	646	954	1,293	1,782	2,415	3,456	4,683
1,400	97	221	299	557	754	1,113	1,508	2,079	2,817	4,032	5,463
1,600	110	252	341	636	862	1,272	1,724	2,376	3,220	4,608	6,244
1,800	124	284	384	716	970	1,431	1,939	2,673	3,622	5,184	7,024
2,000	138	315	427	795	1,077	1,590	2,154	2,970	4,024	5,760	7,805
2,200	152	347	470	875	1,185	1,749	2,370	3,267	4,427	6,336	8,585
2,400	165	378	512	954	1,293	1,908	2,585	3,564	4,829	6,912	9,366
2,600	179	410	555	1,034	1,400	2,067	2,801	3,861	5,232	7,488	10,146
2,800	193	441	598	1,113	1,508	2,226	3,016	4,158	5,634	8,064	10,927
3,000	207	473	640	1,193	1,616	2,385	3,232	4,455	6,037	8,640	11,707
3,200	221	504	683	1,272	1,724	2,544	3,447	4,752	6,439	9,216	12,488
3,400	234	536	726	1,352	1,831	2,703	3,663	5,049	6,841	9,792	13,268
3,600	248	567	768	1,431	1,939	2,862	3,878	5,346	7,244	10,368	14,049
3,800	262	599	811	1,511	2,047	3,021	4,093	5,643	7,646	10,944	14,829
4,000	276	630	854	1,590	2,154	3,180	4,309	5,940	8,049	11,520	15,610
4,200	290	662	896	1,670	2,262	3,339	4,524	6,237	8,451	12,096	16,390
4,400	303	693	939	1,749	2,370	3,498	4,740	6,534	8,854	12,672	17,171
4,600	317	725	982	1,829	2,478	3,657	4,955	6,831	9,256	13,248	17,951
4,800	331	756	1,024	1,908	2,585	3,816	5,171	7,128	9,659	13,824	18,732
5,000	345	788	1,067	1,988	2,693	3,975	5,386	7,425	10,061	14,400	19,512
5,200	359	819	1,110	2,067	2,801	4,134	5,602	7,722	10,463	14,976	20,293
5,400	372	851	1,152	2,147	2,909	4,293	5,817	8,019	10,866	15,552	21,073
5,600	386	882	1,195	2,226	3,016	4,452	6,033	8,316	11,268	16,128	21,854
5,800	400	914	1,238	2,306	3,124	4,611	6,248	8,613	11,671	16,704	22,634
6,000	414	945	1,280	2,385	3,232	4,770	6,463	8,910	12,073	17,280	23,415
6,200	427	977	1,323	2,465	3,339	4,929	6,679	9,207	12,476	17,856	24,195
6,400	441	1,008	1,366	2,544	3,447	5,088	6,894	9,504	12,878	18,432	24,976
6,600	455	1,040	1,409	2,624	3,555	5,247	7,110	9,801	13,280	19,008	25,756
6,800	469	1,071	1,451	2,703	3,663	5,406	7,325	10,098	13,683	19,584	26,537
7,000	483	1,103	1,494	2,783	3,770	5,565	7,541	10,395	14,085	20,160	27,317
7,200	496	1,134	1,537	2,862	3,878	5,724	7,756	10,692	14,488	20,736	28,098
7,400	510	1,166	1,579	2,942	3,986	5,883	7,972	10,989	14,890	21,312	28,878
7,600	524	1,197	1,622	3,021	4,093	6,042	8,187	11,286	15,293	21,888	29,659
7,800	538	1,229	1,665	3,101	4,201	6,201	8,402	11,583	15,695	22,464	30,439
8,000	552	1,260	1,707	3,180	4,309	6,360	8,618	11,880	16,098	23,040	31,220
8,200	565	1,292	1,750	3,260	4,417	6,519	8,833	12,177	16,500	23,616	32,000
8,400	579	1,323	1,793	3,339	4,524	6,678	9,049	12,474	16,902	24,192	32,780
8,600	593	1,355	1,835	3,419	4,632	6,837	9,264	12,771	17,305	24,768	33,561
8,800	607	1,386	1,878	3,498	4,740	6,996	9,480	13,068	17,707	25,344	34,341
9,000	621	1,418	1,921	3,578	4,848	7,155	9,695	13,365	18,110	25,920	35,122
9,200	634	1,449	1,963	3,657	4,955	7,314	9,911	13,662	18,512	26,496	35,902
9,400	648	1,481	2,006	3,737	5,063	7,473	10,126	13,959	18,915	27,072	36,683
9,600	662	1,512	2,049	3,816	5,171	7,632	10,341	14,256	19,317	27,648	37,463
9,800	676	1,544	2,091	3,896	5,278	7,791	10,557	14,553	19,720	28,224	38,244
10,000	689	1,575	2,134	3,975	5,386	7,950	10,772	14,850	20,122	28,800	39,024

# MEASUREMENTS / SPECIFICATIONS

## Conversion Formulas

### TWHC High Cycle Hydraulic Torque Wrench Pressure - Torque Conversion Chart

Pump Pressure		Torque Output							
		TWHC1		TWHC3		TWHC6		TWHC50	
PSI	BAR	lbf.ft.	Nm	lbf.ft.	Nm	lbf.ft.	Nm	lbf.ft.	Nm
1,200	83	170	230	376	510	726	984	6360	8618
1,400	97	198	268	439	595	847	1,148	7420	10054
1,600	110	226	306	502	680	968	1,312	8480	11491
1,800	124	254	345	564	765	1,089	1,476	9540	12927
2,000	138	283	383	627	850	1,210	1,640	10600	14363
2,200	152	311	421	690	935	1,331	1,804	11660	15799
2,400	165	339	460	753	1,020	1,452	1,967	12720	17236
2,600	179	367	498	815	1,105	1,573	2,131	13780	18672
2,800	193	396	536	878	1,190	1,694	2,295	14840	20108
3,000	207	424	574	941	1,275	1,815	2,459	15900	21545
3,200	221	452	613	1,004	1,360	1,936	2,623	16960	22981
3,400	234	480	651	1,066	1,445	2,057	2,787	18020	24417
3,600	248	509	689	1,129	1,530	2,178	2,951	19080	25854
3,800	262	537	728	1,192	1,615	2,299	3,115	20140	27290
4,000	276	565	766	1,254	1,700	2,420	3,279	21200	28726
4,200	290	593	804	1,317	1,785	2,541	3,443	22260	30163
4,400	303	622	842	1,380	1,870	2,662	3,607	23320	31599
4,600	317	650	881	1,443	1,955	2,783	3,771	24380	33035
4,800	331	678	919	1,505	2,040	2,904	3,935	25440	34472
5,000	345	707	957	1,568	2,125	3,025	4,099	26500	35908
5,200	359	735	996	1,631	2,210	3,146	4,263	27560	37344
5,400	372	763	1,034	1,693	2,295	3,267	4,427	28620	38780
5,600	386	791	1,072	1,756	2,380	3,388	4,591	29680	40217
5,800	400	820	1,110	1,819	2,465	3,509	4,755	30740	41653
6,000	414	848	1,149	1,882	2,550	3,630	4,919	31800	43089
6,200	427	876	1,187	1,944	2,635	3,751	5,083	32860	44526
6,400	441	904	1,225	2,007	2,720	3,872	5,247	33920	45962
6,600	455	933	1,264	2,070	2,805	3,993	5,411	34980	47398
6,800	469	961	1,302	2,132	2,890	4,114	5,575	36040	48835
7,000	483	989	1,340	2,195	2,975	4,235	5,738	37100	50271
7,200	496	1,017	1,379	2,258	3,060	4,356	5,902	38160	51707
7,400	510	1,046	1,417	2,321	3,144	4,477	6,066	39220	53144
7,600	524	1,074	1,455	2,383	3,229	4,598	6,230	40280	54580
7,800	538	1,102	1,493	2,446	3,314	4,719	6,394	41340	56016
8,000	552	1,130	1,532	2,509	3,399	4,840	6,558	42400	57453
8,200	565	1,159	1,570	2,572	3,484	4,961	6,722	43460	58889
8,400	579	1,187	1,608	2,634	3,569	5,082	6,886	44520	60325
8,600	593	1,215	1,647	2,697	3,654	5,203	7,050	45580	61762
8,800	607	1,243	1,685	2,760	3,739	5,324	7,214	46640	63198
9,000	621	1,272	1,723	2,822	3,824	5,445	7,378	47700	64634
9,200	634	1,300	1,761	2,885	3,909	5,566	7,542	48760	66070
9,400	648	1,328	1,800	2,948	3,994	5,687	7,706	49820	67507
9,600	662	1,356	1,838	3,011	4,079	5,808	7,870	50880	68943
9,800	676	1,385	1,876	3,073	4,164	5,929	8,034	51940	70379
10,000	689	1,413	1,915	3,136	4,249	6,050	8,198	53000	71816

## Recommended Bolt Stresses for ANSI B16.5, BS1560 and MSS SP44 Flanges

Nom Bore	Flange Class					
	150 lb (PN20)	300 lb (PN50)	600 lb (PN100)	900 lb (PN150)	1,500 lb (PN250)	2,500 lb (PN420)
1/2" (15)	4 x 1/2" (M14)	4 x 1/2" (M14)	4 x 1/2" (M14)	4 x 3/4" (M20)	4 x 3/4" (M20)	4 x 3/4" (M20)
3/4" (20)	4 x 1/2" (M14)	4 x 5/8" (M16)	4 x 5/8" (M16)	4 x 3/4" (M20)	4 x 3/4" (M20)	4 x 3/4" (M20)
1" (25)	4 x 1/2" (M14)	4 x 5/8" (M16)	4 x 5/8" (M16)	4 x 7/8" (M24)	4 x 7/8" (M24)	4 x 7/8" (M24)
1-1/4" (32)	4 x 1/2" (M14)	4 x 5/8" (M16)	4 x 5/8" (M16)	4 x 7/8" (M24)	4 x 7/8" (M24)	4 x 1" (M27)
1-1/2" (40)	4 x 1/2" (M14)	4 x 3/4" (M20)	4 x 3/4" (M20)	4 x 1" (M27)	4 x 1" (M27)	4 x 1-1/8" (M30)
2" (50)	4 x 5/8" (M16)	8 x 5/8" (M16)	8 x 5/8" (M16)	8 x 7/8" (M24)	8 x 7/8" (M24)	8 x 1" (M27)
2-1/2" (65)	4 x 5/8" (M16)	8 x 3/4" (M20)	8 x 3/4" (M20)	8 x 1" (M27)	8 x 1" (M27)	8 x 1-1/8" (M30)
3" (80)	4 x 5/8" (M16)	8 x 3/4" (M20)	8 x 3/4" (M20)	8 x 7/8" (M24)	8 x 1-1/8" (M30)	8 x 1-1/4" (M33)
4" (100)	8 x 5/8" (M16)	8 x 3/4" (M20)	8 x 7/8" (M24)	8 x 1-1/8" (M30)	8 x 1-1/4" (M33)	8 x 1-1/2" (M39)
5" (125)	8 x 3/4" (M20)	8 x 3/4" (M20)	8 x 1" (M27)	8 x 1-1/4" (M33)	8 x 1-1/2" (M39)	8 x 1-3/4" (M45)
6" (150)	8 x 3/4" (M20)	12 x 3/4" (M20)	12 x 1" (M27)	12 x 1-1/8" (M30)	12 x 1-3/8" (M36)	8 x 2" (M52)
8" (200)	8 x 3/4" (M20)	12 x 7/8" (M24)	12 x 1-1/8" (M30)	12 x 1-3/8" (M36)	12 x 1-5/8" (M42)	12 x 2" (M52)
10" (250)	12 x 7/8" (M24)	16 x 1" (M27)	16 x 1-1/4" (M33)	16 x 1-3/8" (M36)	12 x 1-7/8" (M48)	12 x 2-1/2" (M64)
12" (300)	12 x 7/8" (M24)	16 x 1-1/8" (M30)	20 x 1-1/4" (M33)	20 x 1-3/8" (M36)	16 x 2" (M52)	12 x 2-3/4" (M70)
14" (350)	12 x 1" (M27)	20 x 1-1/8" (M30)	20 x 1-3/8" (M36)	20 x 1-1/2" (M39)	16 x 2-1/4" (M56)	
16" (400)	16 x 1" (M27)	20 x 1-1/4" (M33)	20 x 1-1/2" (M39)	20 x 1-5/8" (M42)	16 x 2-1/2" (M64)	
18" (450)	16 x 1-1/8" (M30)	24 x 1-1/4" (M33)	20 x 1-5/8" (M42)	20 x 1-7/8" (M48)	16 x 2-3/4" (M70)	
20" (500)	20 x 1-1/8" (M30)	24 x 1-1/4" (M33)	24 x 1-5/8" (M42)	20 x 2" (M52)	16 x 3" (M76)	
24" (600)	20 x 1-1/4" (M33)	24 x 1-1/2" (M39)	24 x 1-7/8" (M48)	20 x 2-1/2" (M64)	16 x 3-1/2" (M90)	
26" (650)	24 x 1-1/4" (M33)	28 x 1-5/8" (M42)	24 x 1-7/8" (M48)	20 x 2-3/4" (M70)		
28" (700)	28 x 1-1/4" (M33)	28 x 1-5/8" (M42)	28 x 2" (M52)	20 x 3" (M76)		
30" (750)	28 x 1-1/4" (M33)	28 x 1-3/4" (M45)	28 x 2" (M52)	20 x 3" (M76)		
32" (800)	28 x 1-1/2" (M39)	28 x 1-7/8" (M48)	28 x 2-1/4" (M56)	20 x 3-1/4" (M85)		
34" (850)	32 x 1-1/2" (M39)	28 x 1-7/8" (M48)	28 x 2-1/4" (M56)	20 x 3-1/2" (M90)		
36" (90)	32 x 1-1/2" (M39)	32 x 2" (M52)	28 x 2-1/2" (M64)	20 x 3-1/2" (M90)		

### Recommended Bolt Stress

40,000 lbf/in<sup>2</sup>
 45,000 lbf/in<sup>2</sup>
 50,000 lbf/in<sup>2</sup>

The above stress levels are suitable for flanges with a minimum material yield stress of 30,000 lb/in<sup>2</sup> and bolt material grades ASTM A193 B7, B16, B7M and ASTM A320 L7, L43, L7M.

Information is used at the owner's discretion. All data is given in good faith and without acceptance of responsibility on the part of SPX.

## MEASUREMENTS / SPECIFICATIONS

### Reference Tables

### Typical Co-Efficient Values For Bolt Lubricants

Manufacturer	Product	Coefficient of Friction
Acheson Colloids	Anti seize	0.09
	DAG580 (Dry Lubricant)	0.16
Belzona Molecular Ltd	HP anti seize	0.15
	Copperslip	0.09
Bostik Ltd	Never seez Std grade (NS160)	0.18
	Never seez Spl grade (NS165)	0.18
Castrol	Castrol Nucleol S202	0.08
	Spherol Castrol	0.13
Comma Oil & Chemicals	Copper Ease	0.14
Chemodex	Coppergrease	0.15
Chesterton International	Anti Seize (paste)	0.14
Dow Corning	Molykote Cu-7439	0.15
	Molykote 1000	0.11
	Molykote G-Rapid	0.08
	Molykote G-Rapid Plus	0.09
Fordec	Fordec Copper Anti seize	0.15
Ilex Lubricants	Coppercrest	0.14
Molyslip	Molyslip AS60	0.07
National Chemical Co	Thread Eze	0.18
	Copaslip	0.12
OKS	OKS 240	0.12
	OKS 250	0.08
K.S. Paul	Easyrun 100	0.08
	PBC	0.13
	PBC/D Lead Free	0.12
	516	0.18
Rocol	Rocol ASP	0.10
	Rocol J166	0.15
	Rocol 797	0.16
Silkolene	Silkease Copper	0.14
Sovereign Lubricants	Omega 99	0.13
	Omega 99N	0.09
	Omega 95	0.12
Swan Chemicals	Swanlube	0.12
James Walker	Walkers Anti seize No 203	0.15
Wessex Chemical Factors	WCF Anti Seize	0.15

# MEASUREMENTS / SPECIFICATIONS

## Torque Requirements for Imperial Bolts

### IMPERIAL TORQUE (Values = lbf ft)

Bolt Diameter Nut A/F	1/2"		5/8"		3/4"		7/8"		1"		1-1/8"		1-1/4"		1-3/8"		1-1/2"		1-5/8"		1-3/4"		2"		2-1/4"		2-1/2"		2-3/4"		3"		3-1/4"		3-1/2"		3-3/4"		4"							
	in	in	in	in	in	in	in	in	in	in	in	in	in	in	in	in	in	in	in	in	in	in	in	in	in	in	in	in	in	in	in	in	in	in	in	in	in	in	in	in						
Torque figures in this section will induce Residual Bolt Loads equivalent to the white/grey section in the Imperial Torque table on the next page. These values are typical for clamp connectors	µ = 0.08	17	33	58	93	138	200	278	375	491	629	790	978	1,192	1,508	1,968	2,536	3,224	4,044	5,000	6,144	7,472	9,000	10,832	12,960	15,392	18,128	21,168	24,512	28,160	32,112	36,368	40,928	45,792	50,960	56,432	62,208	68,288	74,672	81,360						
	µ = 0.11	22	43	76	122	181	263	368	497	653	838	1,055	1,309	1,598	1,924	2,288	2,691	3,134	3,616	4,138	4,699	5,299	5,937	6,613	7,327	8,079	8,869	9,697	10,563	11,467	12,409	13,389	14,407	15,463	16,557	17,689	18,859	20,067	21,313	22,597	23,919					
	µ = 0.13	26	50	88	141	209	306	428	579	761	977	1,231	1,529	1,868	2,244	2,657	3,106	3,594	4,121	4,687	5,292	5,936	6,619	7,341	8,093	8,875	9,687	10,529	11,411	12,333	13,295	14,297	15,339	16,421	17,543	18,705	19,907	21,149	22,431	23,753	25,115	26,517	27,959			
	µ = 0.15	29	57	100	160	238	348	487	660	869	1,117	1,408	1,750	2,138	2,563	3,024	3,521	4,054	4,623	5,228	5,869	6,546	7,259	8,007	8,791	9,611	10,467	11,359	12,287	13,251	14,251	15,287	16,359	17,467	18,611	19,791	21,007	22,259	23,547	24,871	26,231	27,627	29,059	30,527		
Torque figures in this section will induce Residual Bolt Loads equivalent to the green section in the Imperial Torque table on the next page. (276 MPa)	µ = 0.08	27	53	93	148	220	320	445	599	785	1,006	1,263	1,565	1,907	2,284	2,697	3,146	3,630	4,149	4,703	5,292	5,916	6,575	7,268	7,994	8,752	9,542	10,364	11,218	12,104	13,022	13,971	14,951	15,962	17,004	18,077	19,181	20,316	21,482	22,679	23,907	25,166	26,456	27,776	29,127	
	µ = 0.11	35	69	121	194	289	421	568	755	1,044	1,340	1,687	2,094	2,556	3,074	3,641	4,258	4,916	5,614	6,352	7,130	7,948	8,806	9,704	10,642	11,619	12,636	13,693	14,790	15,927	17,104	18,321	19,578	20,875	22,212	23,589	25,006	26,463	27,960	29,497	31,074	32,691	34,348	36,045	37,782	
	µ = 0.13	41	80	140	225	334	488	684	925	1,217	1,564	1,970	2,447	2,989	3,587	4,241	4,951	5,718	6,592	7,474	8,364	9,291	10,254	11,253	12,288	13,359	14,466	15,609	16,788	17,999	19,243	20,520	21,831	23,176	24,555	25,968	27,415	28,896	30,411	31,960	33,543	35,160	36,811	38,496	40,215	
	µ = 0.15	46	91	160	255	380	556	779	1,056	1,390	1,787	2,252	2,799	3,421	4,119	4,894	5,736	6,646	7,624	8,670	9,784	10,956	12,187	13,477	14,826	16,234	17,701	19,228	20,815	22,463	24,173	25,944	27,776	29,669	31,623	33,638	35,714	37,851	40,050	42,311	44,634	47,019	49,466			
Torque figures in this section will induce Residual Bolt Loads equivalent to the yellow section in the Imperial Torque table on the next page. (310 MPa)	µ = 0.08	31	60	104	167	248	359	500	674	883	1,131	1,421	1,761	2,146	2,567	3,024	3,516	4,043	4,605	5,202	5,834	6,501	7,204	7,942	8,715	9,523	10,366	11,244	12,157	13,104	14,085	15,100	16,149	17,232	18,349	19,499	20,682	21,898	23,147	24,429	25,744	27,092	28,474	29,890	31,341	
	µ = 0.11	40	78	137	218	325	474	662	894	1,175	1,508	1,898	2,356	2,876	3,447	4,068	4,729	5,430	6,171	6,952	7,773	8,634	9,535	10,476	11,457	12,478	13,529	14,610	15,721	16,862	18,033	19,234	20,465	21,726	23,017	24,338	25,689	27,070	28,481	29,922	31,393	32,894	34,425	35,986	37,567	
	µ = 0.13	46	90	158	253	376	550	769	1,041	1,369	1,759	2,216	2,752	3,362	4,034	4,766	5,548	6,380	7,261	8,182	9,143	10,144	11,185	12,266	13,387	14,548	15,749	16,990	18,271	19,592	20,953	22,354	23,795	25,276	26,797	28,358	29,959	31,600	33,281	35,002	36,763	38,564	40,405	42,286	44,207	
	µ = 0.15	52	102	180	287	428	626	877	1,188	1,563	2,010	2,534	3,149	3,849	4,634	5,504	6,467	7,524	8,675	9,920	11,259	12,692	14,219	15,840	17,555	19,364	21,267	23,264	25,355	27,540	29,819	32,192	34,659	37,220	39,875	42,624	45,467	48,404	51,435	54,560	57,779	61,092	64,509	68,030	71,655	
Torque figures in this section will induce Residual Bolt Loads equivalent to the red section in the Imperial Torque table on the next page. (345 MPa)	µ = 0.08	34	65	116	185	275	399	556	749	982	1,257	1,579	1,956	2,384	2,853	3,364	3,917	4,512	5,149	5,828	6,549	7,312	8,117	8,964	9,852	10,781	11,751	12,762	13,813	14,904	16,035	17,206	18,417	19,668	20,959	22,290	23,661	25,072	26,523	28,014	29,545	31,116	32,727	34,378	36,069	37,800
	µ = 0.11	44	86	152	243	361	526	735	994	1,305	1,675	2,109	2,617	3,195	3,844	4,574	5,385	6,276	7,247	8,298	9,429	10,640	11,931	13,302	14,753	16,284	17,895	19,586	21,367	23,238	25,199	27,250	29,391	31,622	33,943	36,354	38,855	41,446	44,127	46,908	49,789	52,760	55,821	58,972	62,213	
	µ = 0.13	51	100	176	281	418	611	855	1,157	1,521	1,954	2,462	3,058	3,736	4,495	5,336	6,259	7,264	8,351	9,520	10,771	12,104	13,519	15,016	16,595	18,256	19,999	21,834	23,761	25,780	27,891	29,994	32,189	34,476	36,855	39,326	41,889	44,544	47,291	50,130	53,061	56,084	59,209	62,436	65,765	69,196
	µ = 0.15	58	113	199	319	475	695	974	1,320	1,737	2,233	2,815	3,499	4,276	5,147	6,112	7,171	8,324	9,571	10,912	12,347	13,876	15,499	17,216	19,027	20,932	22,931	25,024	27,211	29,492	31,867	34,336	36,899	39,556	42,307	45,152	48,091	51,124	54,251	57,472	60,787	64,196	67,709	71,326	75,047	78,872

Torque values all shown in lb. ft.

The torque values are for fully threaded UNC (up to 1")/UN8 stud bolts/heavy series nuts. Bolt Materials: ASTM A193 B7, B7M & B16; ASTM A320 L7, L7M & L43

### METRIC TORQUE (Values = Nm)

Bolt Diameter Nut A/F	1/2"		5/8"		3/4"		7/8"		1"		1-1/8"		1-1/4"		1-3/8"		1-1/2"		1-5/8"		1-3/4"		2"		2-1/4"		2-1/2"		2-3/4"		3"		3-1/4"		3-1/2"		3-3/4"		4"						
	in	in	in	in	in	in	in	in	in	in	in	in	in	in	in	in	in	in	in	in	in	in	in	in	in	in	in	in	in	in	in	in	in	in	in	in	in	in	in	in	in				
Torque values in this section will induce residual stress of 25,000 lbf/in <sup>2</sup> (172 MPa). These values are typical for clamp connectors	µ = 0.08	23	45	79	126	187	271	377	508	666	853	1,071	1,326	1,616	2,167	2,533	3,042	3,600	4,217	4,894	5,631	6,428	7,285	8,202	9,180	10,228	11,346	12,534	13,792	15,120	16,518	17,986	19,524	21,132	22,810	24,558	26,376	28,264	30,232	32,280	34,408	36,616	38,904	41,272	43,720
	µ = 0.11	30	58	103	164	245	357	499	674	885	1,136	1,430	1,775	2,167	2,603	3,083	3,616	4,203	4,845	5,543	6,306	7,134	8,027	8,985	9,997	11,074	12,216	13,424	14,698	16,038	17,444	18,916	20,454	22,058	23,728	25,464	27,266	29,134	31,068	33,068	35,134	37,266	39,464	41,728	44,058
	µ = 0.13	35	68	119	191	283	415	580	785	1,032	1,325	1,669	2,073	2,533	3,053	3,634	4,276	4,977	5,738	6,560	7,443	8,387	9,392	10,458	11,585	12,774	14,024	15,336	16,710	18,146	19,644	21,204	22,826	24,510	26,256	28,064	29,934	31,866	33,860	35,916	38,034	40,214	42,456	44,760	47,126
	µ = 0.15	39	77	136	217	323	472	660	895	1,178	1,514	1,909	2,373	2,899	3,491	4,149	4,874	5,666	6,524	7,448	8,438	9,494	10,616	11,804	13,066	14,402	15,812	17,296	18,854	20,486	22,192	23,972	25,826	27,754	29,756	31,832	33,974	36,182	38,456	40,796	43,202	45,674	48,212	50,816	
Torque values in this section will induce residual stress of 40,000 lbf/in <sup>2</sup> (276 MPa).	µ = 0.08	37	72	126	201	298	434	603	812	1,064	1,364	1,712	2,122	2,586	3,106	3,685	4,324	5,023	5,782	6,601	7,480	8,419	9,418	10,477	11,596	12,774	14,012	15,310	16,668	18,086	19,564	21,102	22,700	24,358	26,076	27,854	29,692	31,590	33,548	35,566	37,644	39,782	41,980	44,238	46,556
	µ = 0.11	47	94																																										



# MEASUREMENTS / SPECIFICATIONS

## Torque Requirements for Metric Bolts

### IMPERIAL TORQUE (Values = lbf ft)

Bolt Diameter mm Nut A/F	M14 22	M16 24	M20 30	M24 36	M27 41	M30 46	M33 50	M36 55	M39 60	M42 65	M45 70	M48 75	M52 80	M56 85	M64 95	M70 100	M76 110	M85 120	M90 130
$\mu = 0.08$	18	32	59	97	141	207	286	389	508	657	822	1,026	1,261	1,744	2,465	3,240	4,199	5,463	6,767
$\mu = 0.11$	24	42	77	127	167	272	377	512	670	866	1,086	1,354	1,688	2,305	3,262	4,299	5,587	7,290	9,046
$\mu = 0.13$	27	48	89	147	215	316	437	594	779	1,005	1,261	1,572	1,939	2,679	3,794	5,005	6,512	8,508	10,566
$\mu = 0.15$	31	55	101	167	245	359	498	676	887	1,144	1,437	1,791	2,210	3,063	4,325	5,711	7,437	9,726	12,085
Torque figures in this section will induce Residual Bolt Loads equivalent to the green section in the Imperial Torque table on the previous page.	29	51	94	155	225	332	457	623	812	1,051	1,314	1,642	2,017	2,790	3,943	5,183	6,718	8,740	10,827
Torque figures in this section will induce Residual Bolt Loads equivalent to the yellow section in the Imperial Torque table on the previous page.	38	66	123	203	296	436	602	819	1,072	1,385	1,737	2,166	2,688	3,687	5,218	6,877	8,938	11,663	14,474
Torque figures in this section will induce Residual Bolt Loads equivalent to the red section in the Imperial Torque table on the previous page.	43	77	142	235	344	505	699	951	1,246	1,607	2,018	2,516	3,102	4,286	6,069	8,007	10,418	13,612	16,905
	49	87	161	267	391	574	796	1,082	1,419	1,830	2,299	2,865	3,536	4,884	6,919	9,137	11,898	15,561	19,336
	32	57	105	174	253	373	504	701	914	1,182	1,479	1,847	2,269	3,139	4,436	5,831	7,558	9,832	12,180
	42	75	138	228	333	490	677	922	1,206	1,558	1,954	2,437	3,001	4,148	5,871	7,737	10,055	13,121	16,283
	49	86	159	264	387	568	786	1,069	1,401	1,809	2,270	2,830	3,490	4,821	6,827	9,008	11,721	15,314	19,018
	55	98	181	300	440	646	895	1,217	1,596	2,058	2,587	3,223	3,978	5,494	7,784	10,279	13,386	17,507	21,753
	36	63	117	194	282	414	571	778	1,015	1,313	1,643	2,062	2,521	3,487	4,929	6,479	8,397	10,925	13,534
	47	83	153	253	370	544	753	1,024	1,340	1,731	2,171	2,707	3,335	4,609	6,523	8,597	11,173	14,579	18,092
	54	96	177	293	430	631	874	1,188	1,567	2,009	2,522	3,144	3,877	5,357	7,586	10,009	13,023	17,015	21,131
	61	109	201	333	489	717	995	1,352	1,773	2,287	2,874	3,581	4,420	6,105	8,649	11,421	14,873	19,452	24,169

Torque values all shown in lb. ft.

The torque values are for fully threaded coarse metric stud bolts/standard series nuts. Bolt Materials: ASTM A193 B7, B7M & B16; ASTM A320 L7, L7M & L43

### METRIC TORQUE (Values = Nm)

Bolt Diameter mm Nut A/F	M14 22	M16 24	M20 30	M24 36	M27 41	M30 46	M33 50	M36 55	M39 60	M42 65	M45 70	M48 75	M52 80	M56 85	M64 95	M70 100	M76 110	M85 120	M90 130
$\mu = 0.08$	24	43	80	132	191	281	388	527	689	891	1,114	1,391	1,710	2,365	3,342	4,393	5,693	7,407	9,175
$\mu = 0.11$	33	57	104	172	226	369	511	694	908	1,174	1,472	1,836	2,262	3,125	4,423	5,829	7,575	9,884	12,265
$\mu = 0.13$	37	65	121	199	292	428	592	805	1,056	1,363	1,710	2,131	2,629	3,632	5,144	6,786	8,829	11,335	14,326
$\mu = 0.15$	42	75	137	226	332	487	675	917	1,203	1,551	1,948	2,428	2,996	4,139	5,864	7,743	10,083	13,187	16,385
Torque figures in this section will induce Residual Bolt Loads equivalent to the green section in the Imperial Torque table on the previous page.	39	69	127	210	305	450	620	845	1,101	1,425	1,782	2,226	2,735	3,783	5,346	7,027	9,108	11,850	14,679
Torque figures in this section will induce Residual Bolt Loads equivalent to the yellow section in the Imperial Torque table on the previous page.	52	89	167	275	401	591	816	1,110	1,453	1,878	2,355	2,937	3,617	4,999	7,075	9,324	12,118	15,813	19,624
Torque figures in this section will induce Residual Bolt Loads equivalent to the red section in the Imperial Torque table on the previous page.	58	104	193	319	466	685	948	1,289	1,689	2,179	2,736	3,411	4,206	5,811	8,228	10,856	14,125	18,455	22,920
	66	118	218	362	530	778	1,079	1,467	1,924	2,481	3,117	3,894	4,794	6,622	9,381	12,388	16,132	21,098	26,216
	43	77	142	236	343	506	683	950	1,239	1,603	2,005	2,504	3,076	4,256	6,014	7,906	10,247	13,330	16,514
	57	102	187	309	451	664	918	1,250	1,635	2,112	2,649	3,304	4,069	5,624	7,960	10,490	13,633	17,790	22,077
	66	117	216	358	525	770	1,066	1,449	1,900	2,453	3,078	3,837	4,732	6,536	9,256	12,213	15,892	20,763	25,785
	75	133	245	407	597	876	1,213	1,650	2,184	2,790	3,508	4,370	5,393	7,449	10,554	13,936	18,149	23,736	29,493
	49	85	159	263	382	561	774	1,055	1,376	1,780	2,228	2,782	3,418	4,728	6,683	8,784	11,385	14,812	18,350
	64	113	207	343	502	738	1,021	1,388	1,817	2,347	2,943	3,670	4,522	6,249	8,844	11,656	15,149	19,767	24,529
	73	130	240	397	583	856	1,185	1,611	2,111	2,724	3,419	4,263	5,257	7,263	10,285	13,570	17,657	23,069	28,650
	83	148	273	451	663	972	1,349	1,833	2,404	3,101	3,897	4,855	5,993	8,277	11,726	15,485	20,165	26,373	32,769

Torque values all shown in Nm

## SPX BOLT TENSIONERS HOW IT WORKS

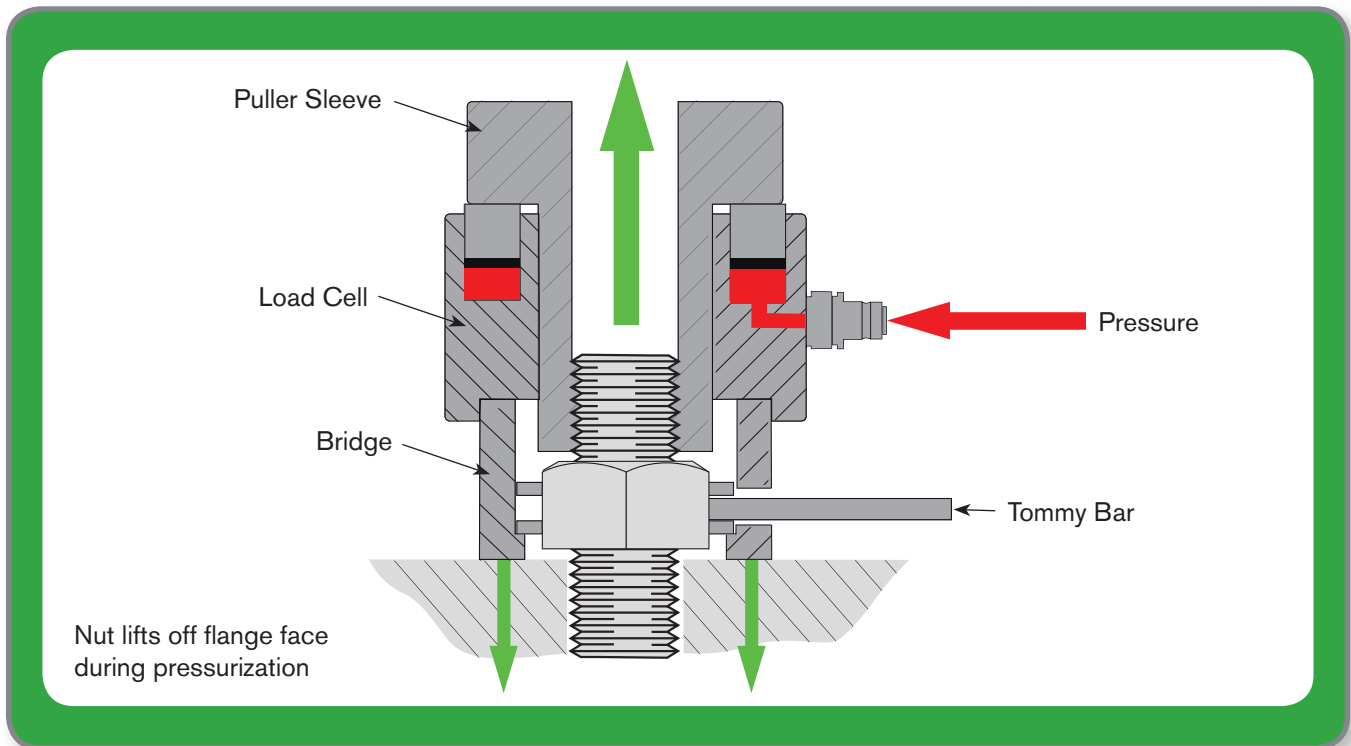

Hydraulic tensioning is a method of stretching the stud in lieu of turning the nut as with traditional torquing. Each stud has a yield strength, and can be stretched as a form of tightening, eliminating galling and friction, and the need for lubricants.

Hydraulic Bolt Tensioners are used to provide the most accurate residual bolt load and uniform compression on the gasket. The bolt tensioner can be applied to a single bolt or any number of bolts depending upon access and the application. However, to give the most accurate residual load, a bolt tensioner should be placed on, ideally, 50% or 100% of the studs. (See graphic next page).

The load cell and adapter kit is placed over the top of each stud and nut. The puller is then threaded onto the stud above the nut and sits flush against the hydraulic load cell. Each tool is interconnected with hoses to insure all tools are pressurized simultaneously.

The hydraulic pump unit is activated and as pressure builds throughout the system. The load cell starts to extend and push against the puller, stretching the stud. As this continues, the nut lifts off the flange face. Once the desired pressure is met, the pump valve is closed to

hold the pressure. The socket ring is turned down using a tommy bar so the nut is now back sitting flush on the flange face. Once all the nuts have been turned down, the pump pressure is released and the stud attempts to return to its normal state thus creating a clamping force on the gasket. Since all bolts are tightened at the same time, this provides a uniform load across the joint.

## TYPICAL 50% TENSIONER LAYOUT



Assemble tensioners to 50% of the bolts.  
Apply 'Pressure 1' as indicated on the bolt tensioning data sheet.  
Tighten down the nuts using a tommy bar.



Move the tensioners to the remaining 50% of the bolts and apply 'Pressure 2' as indicated on the bolt tensioning data sheet.  
Tighten down the nuts using a tommy bar.

Release the system pressure and repeat the reapplication of the pressure and tightening of the nuts a further twice.

## TYPICAL 50% FLANGE SET-UP

For proper tensioner tool fit, there must be ample stud above the nut

50% Bolt Tensioning

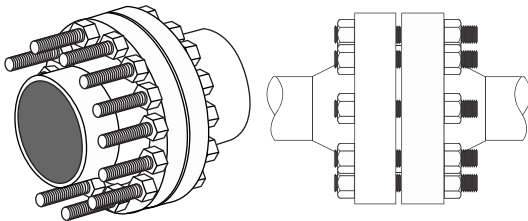

100% Bolt Tensioning

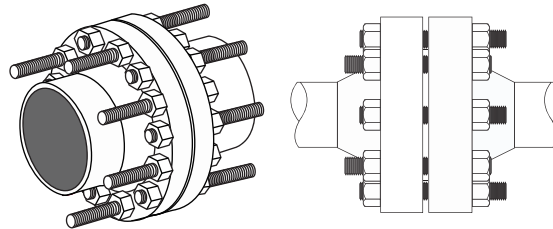

For topside applications, make sure the stud extends a minimum of one bolt diameter above the nut. For subsea applications, refer to the SPX SST tool selection chart for dimension.

100% Tensioning Set-up for Subsea Tensioning

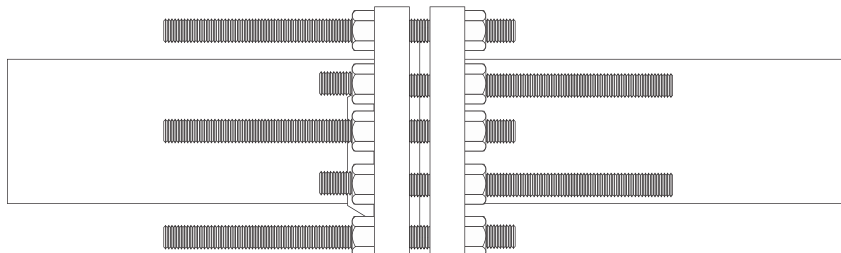

# HYDRAULIC BOLTING SAFETY

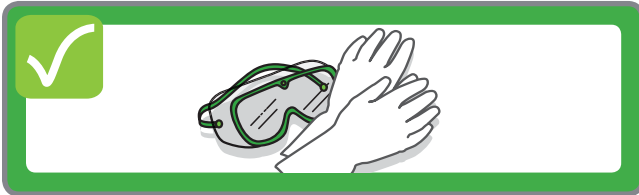

Wear appropriate Personal Protective Equipment (PPE).



Read all instructions and safety warnings before using the pumps, tools and other equipment.



Do not exceed the rated load of any pump, tool or component.

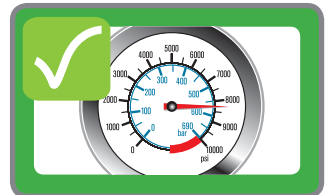

Inspect all components before use. Do not use damaged or worn components. Return to an Authorized Repair Center for repair or replacement.



Never alter internal relief valves.

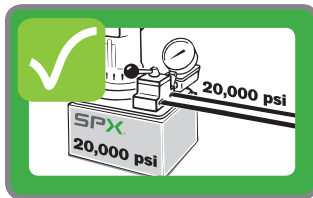
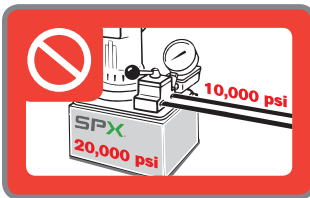

Recognize system pressures. Do not use a 20,000 PSI pump on a system with 10,000 PSI components (hoses, fittings, valves, tools, etc.).

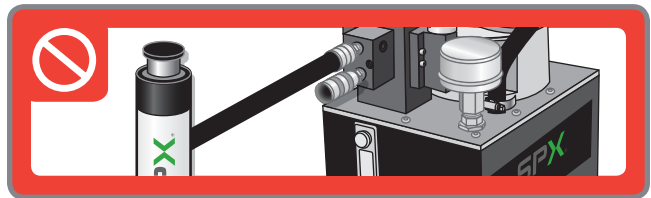

Do not use pumps designed for torque wrenches or tensioners for lifting.



Do not overfill pump reservoirs.



Use only high quality oil, like SPX Power Team hydraulic oil. Using the wrong fluid can lead to equipment damage and premature failure.



Do not use the same oil in all equipment and in all environments.

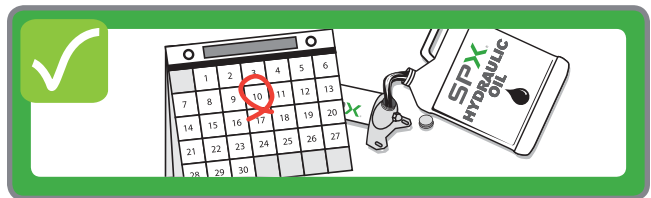

Change oil and/or filters at appropriate intervals.

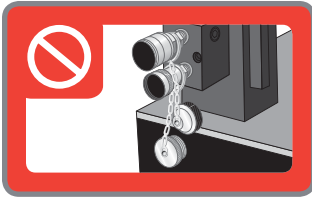

Do not operate a pump with couplers exposed or uncapped.

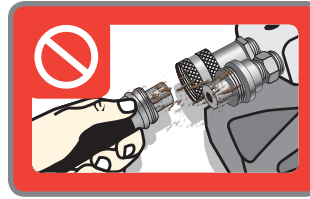
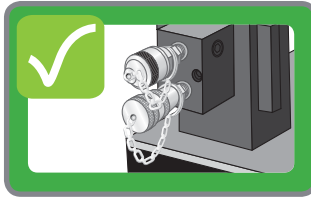

Clean both ends of the couplers before assembly.



Do not kink hydraulic hoses.



Replace damaged hoses immediately.



Keep equipment away from excessive temperatures. Do not weld next to unprotected equipment.



Keep couplers capped when not in use.



Do not drive over hoses or drop objects onto them.

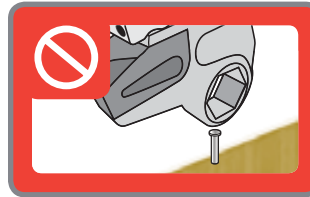

Only use tools for their intended purpose.

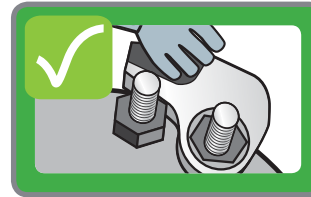

Keep hands clear of pinch points.

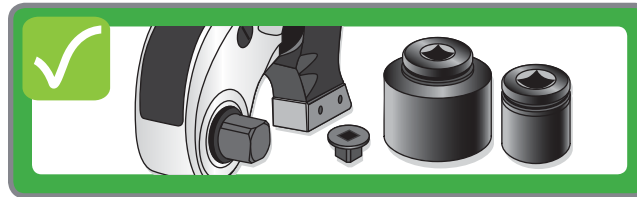
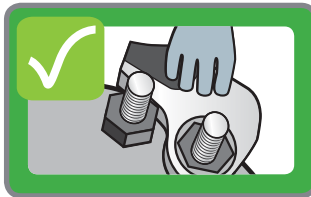

Only use high quality impact sockets and reducers with an appropriate load rating and safety factor.

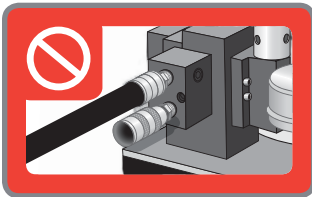

Always connect both torque wrench hoses to the pump. Do not operate with only one hose attached.

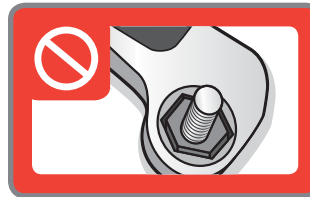
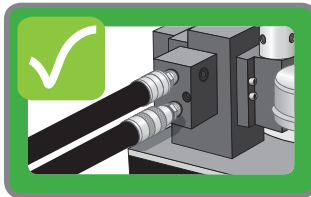

Use only the proper size sockets and links.



# APPLICATION DATA SHEET

Nut Type 1		
$\varnothing d$	in/mm	
P (Pitch)	in/mm	
H1	in/mm	
H2	in/mm	
AF	in/mm	
$\varnothing W$	in/mm	

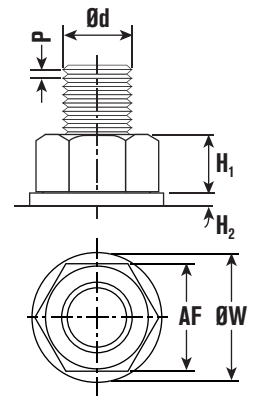

**Nut Type 1**

Circle "in" or "mm"

Nut Type 2		
$\varnothing d$	in/mm	
P (Pitch)	in/mm	
H1	in/mm	
H2	in/mm	
$\varnothing N$	in/mm	
$\varnothing W$	in/mm	
H3	in/mm	
$\varnothing J$	in/mm	
# of Holes	-	

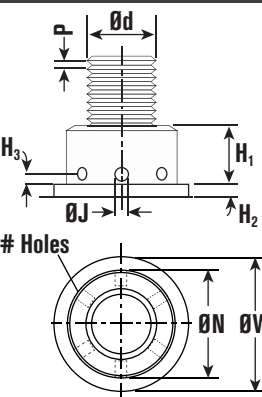

**Nut Type 2**

Circle "in" or "mm"

Application Dimensions		
A	in/mm	
B	in/mm	
C	in/mm	
D	in/mm	
E	in/mm	
G	in/mm	
R	in/mm	
# Bolts	-	
PCD	in/mm	
Additional Information		
Hot Dip Galvanized Threads : Y / N		

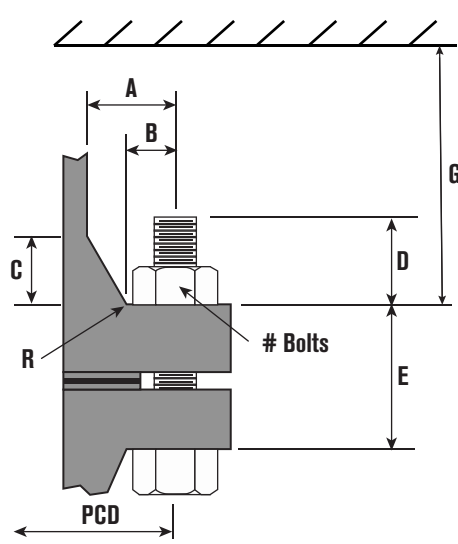

Circle "in" or "mm"

Load Requirements		
APPLIED HYDRAULIC LOAD ( $F_{HA}$ )	N	
RESIDUAL BOLT LOAD ( $F_{RB}$ )	N	

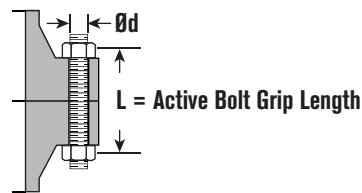
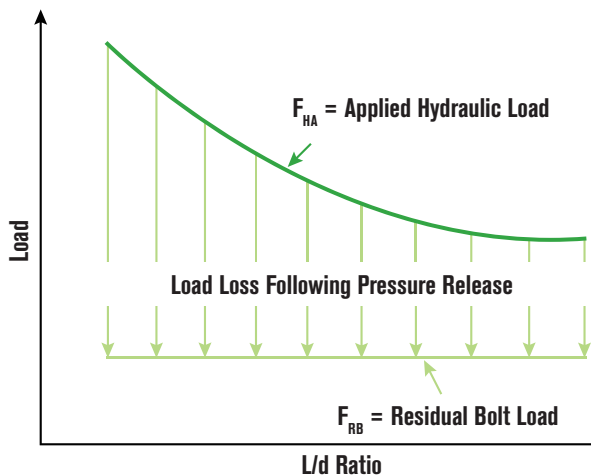

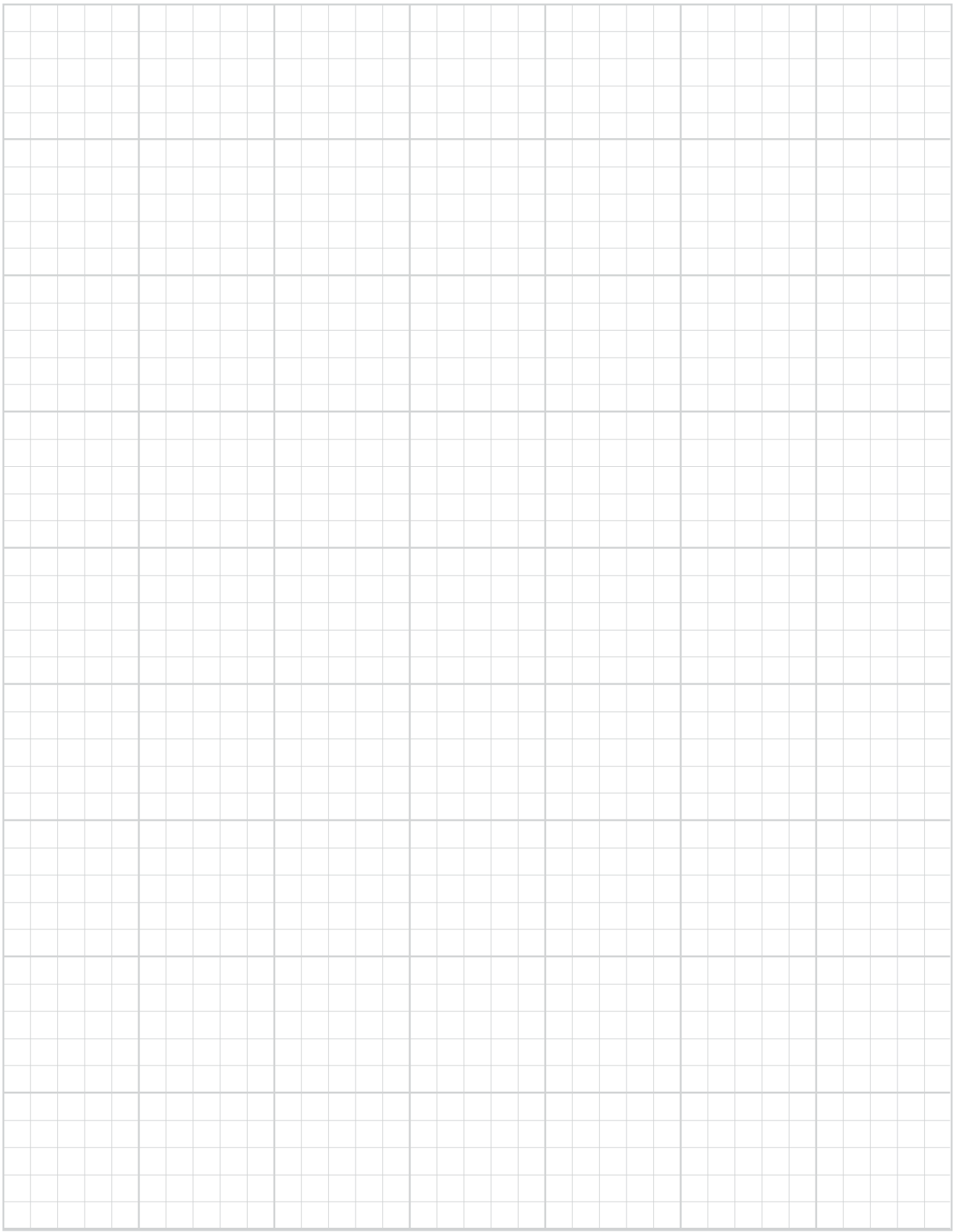

# MEASUREMENTS / SPECIFICATIONS

## Manufacturing Standards

Bolting Systems' commitment to quality is evident in everything we do, from raw material receipt to how we support our customers years after they purchase our products. Bolting Systems is registered to ISO 9001: 2000 international quality standard. ISO 9001: 2000 requires compliance with standards for management, administration, product development, manufacturing and continual improvement. Our Registration verifies that Bolting Systems has adopted and maintains documentation for processes ranging from suppliers to customers, inspection, handling, and training. ISO 9001 also requires periodic internal and external audits to ensure all aspects of work affecting quality control are monitored. This always has been, and will continue to be, our philosophy. That's our guarantee to you.

### ASME B30.1

Some Bolting Systems tools are made using Power Team hydraulic cylinders which fully comply with the criteria set forth in the American Society of Mechanical Engineers standard ASME B30.1:

Our cylinders are designed to have a minimum of a 2-to-1 safety factor on typical material yield strength; Each cylinder is tested at 125 percent of rated pressure at full travel and is inspected to assure functionality and freedom from leaks.

### ASME B40.1

Bolting Systems heavy-duty pressure gauges are designed in accordance with the recommendations set forth in the American Society of Mechanical Engineers standard ASME B40.1, Grade 1A or B.

### CE MARK

Bolting Systems is committed to designing, manufacturing, and marketing products that meet or exceed the needs of the customers we serve. Bolting Systems supplies a Declaration of Incorporation or a Declaration of Conformity and CE Marking for products that conform with European Community Directives.

### IJ100

Bolting Systems hoses meet the criteria set forth in the Material Handling Institute's specification #IJ100 for hydraulic hose. Under the procedures outlined in this standard, hydraulic hose shall:

1. Have an average minimum life of 30,000 cycles at full rated capacity.
2. Have a minimum burst pressure of at least twice the rated operating pressure.
  - a. CE compliant hoses have a 4:1 burst rate over nominal operating pressure.

### CSA

Where specified, Bolting Systems electric power pump assemblies meet the design, assembly, and test requirements of the Canadian Standards Association. Note: If CSA certification is required, it must be requested at the time the pump is ordered.

### NEMA

Where specified, Bolting Systems electric power pump assemblies meet the design, assembly, and test requirements of NEMA 12, a National Electrical Manufacturers' Association standard relating to electrical components used to resist moisture and dust.

## BOLTING SYSTEMS PRODUCT DESIGN CRITERIA

All Bolting Systems brand hydraulic components are designed and/or tested to be safe for use at maximum operating pressures of 10,000 psi (690 bar) unless otherwise specifically noted.

### QUALITY ASSURANCE

All of our products are subjected to quality checks during production. All materials are certified and have traceability to the mill. Before leaving the factory, all pressure containing products are tested to maximum working pressure to ensure on-the-job reliability. We have made every effort to include the latest specifications for our products in this catalog. Please call the Bolting Systems factory for the most current product specifications. The Bolting Systems Lifetime Powerthon™ Warranty is described in more detail on page 129 of this catalog.





**POWERTHON™  
LIFETIME  
WARRANTY**

## **▶ Bolting Systems™**

### **POWERTHON™ LIFETIME WARRANTY**

“Bolting Systems” is a registered trademark of the SPX Hydraulic Technologies division of SPX Corporation (“SPX”). All Bolting Systems products and parts, with the exceptions noted below, are warranted against defects in materials and workmanship for the life of the product or part. (The life of the product or part is defined as that point in time when it no longer safely or properly functions due to normal wear). Inflatable jacks, chains, batteries, electric motors, gas engines, knives and cutter blades which are sold with Bolting Systems products are not covered by this warranty and instead are warranted as follows:

Inflatable Jacks and electronics are warranted against defects in materials and workmanship for a period of one year from date of purchase.

Consumable parts or accessories, including without limitation, chains, batteries, knives and cutter blades are warranted against defects in materials and workmanship for a period of one year from date of purchase.

All electric motors and gas engines are separately warranted by their respective manufacturer under the terms and conditions stated in their separate warranty.

The foregoing warranties do not cover ordinary wear and tear or any product or part that has been worn out, abused, heated, ground or otherwise altered, used for a purpose other than that for which it was intended or used in a manner inconsistent with any instructions regarding its use.

To qualify for warranty consideration, return the Bolting Systems product, freight prepaid, to a Bolting Systems authorized repair center or to the SPX factory. If any product or part manufactured by SPX found to be defective by SPX, in its sole judgment, SPX will, at its option, either repair or replace such defective product or part and return it via best ground transportation, freight prepaid. **THIS REMEDY SHALL BE THE EXCLUSIVE REMEDY AVAILABLE FOR ANY DEFECTS IN THE PRODUCTS OR PARTS MANUFACTURED AND SOLD BY SPX OR FOR DAMAGES RESULTING FROM ANY OTHER CAUSE WHATSOEVER, INCLUDING WITHOUT LIMITATION, SPX'S NEGLIGENCE. SPX SHALL NOT, IN ANY EVENT, BE LIABLE TO ANY BUYER FOR CONSEQUENTIAL OR INCIDENTAL DAMAGES OF ANY KIND, WHETHER FOR DEFECTIVE OR NON-CONFORMING GOODS, NEGLIGENCE, ON THE BASIS OF STRICT LIABILITY OR FOR ANY OTHER REASON.**

SPX's Warranty is expressly limited to persons who purchase Bolting Systems products or parts for the resale or for use in the ordinary course of the buyer's business.

**THIS WARRANTY IS EXCLUSIVE, AND SPX MAKES NO OTHER WARRANTY OF ANY KIND WHATSOEVER, EXPRESSED OR IMPLIED, WITH RESPECT TO THE PRODUCTS MANUFACTURED AND SOLD BY IT, WHETHER AS TO MERCHANTABILITY, FITNESS FOR A PARTICULAR PURPOSE, OR ANY OTHER MATTER.** No agent, employee, or representative of SPX has any authority to bind SPX to any affirmation, representation, or warranty concerning Bolting Systems products or parts, except as stated herein.

The purpose of this exclusive remedy shall be to provide the buyer with repair or replacement of products or parts manufactured by SPX found to be defective in materials or workmanship or negligently manufactured. This exclusive remedy shall not be deemed to have failed of its essential purpose so long as SPX is willing and able to replace said defective products or parts in the prescribed manner.



## CUSTOM PRODUCTS AVAILABLE

### SPANNER LINK & REACTION ROLLER



- For low height applications.
- For radially close applications
- Open ended spanner configurations
- Multi-plate applications for extreme low height applications
- Reaction 'roller' rolls around flange periphery during operation
- Manufactured to order

### RING TENSIONER



- Custom tensioners designed to meet specific applications needs.

Contact your SPX representative for details on any of these custom products or we can develop a custom product for your application.

## THREADED PISTON TENSIONERS



### THREADED PISTON TENSIONERS FOR WIND TURBINE LOAD CHECKS

- Compact size
- High load
- Simple assembly
- Cost effective
- Light-weight and flexible
- Manufactured to order

## TWHC ACCESSORIES



### CUSTOM WRENCH ACCESSORIES AVAILABLE

Should our standard reaction device be unsuitable, SPX can design special reaction devices and drives upon request.

