

Kreiselpumpen Typ T
Centrifugal pumps type T

KNOLL
.It works

Ausgabe | Issue | 08-2012

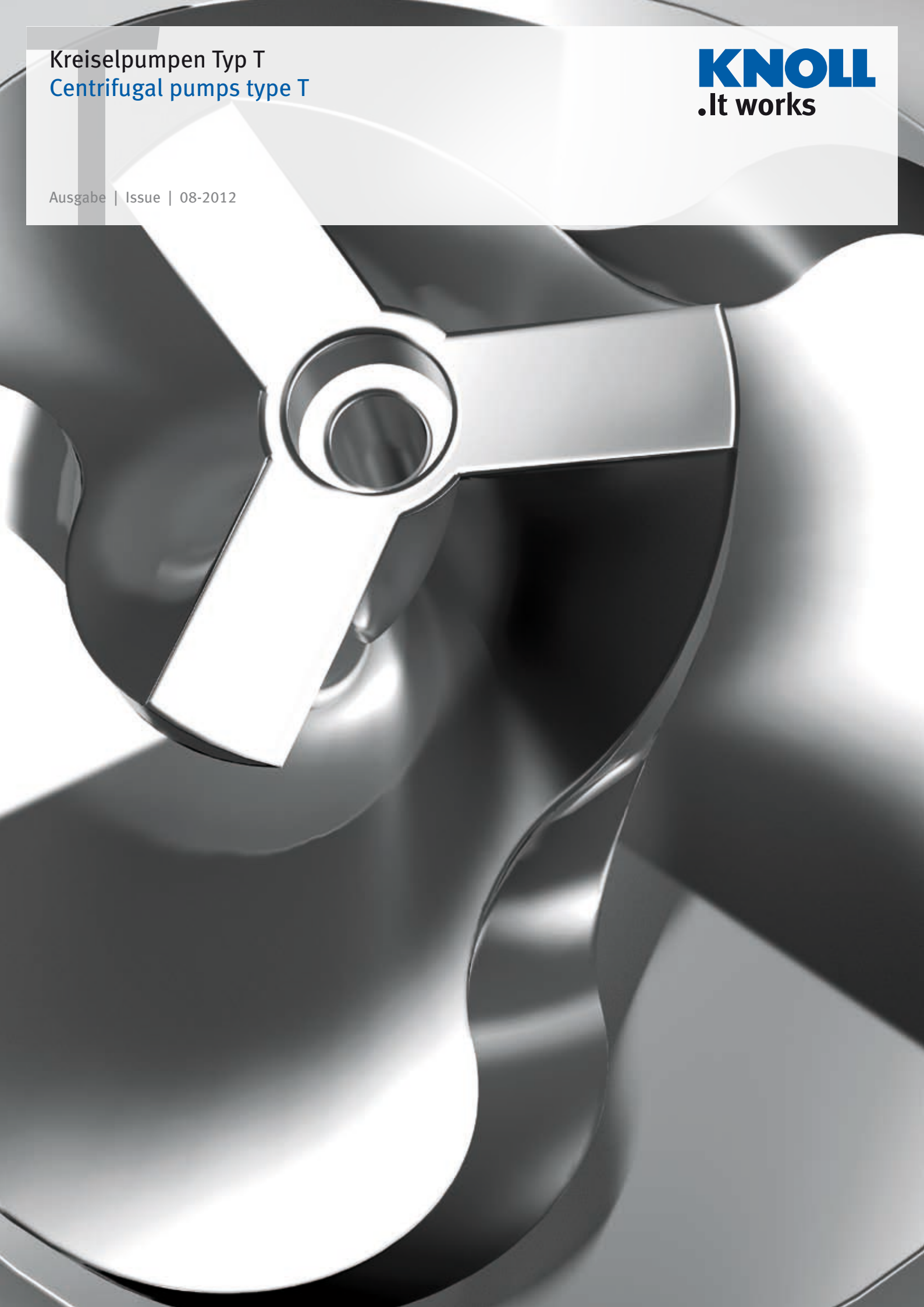

Eigenschaften. Properties.

1.

Sehr hoher Wirkungsgrad durch strömungstechnisch günstig geformtes Laufrad

Very high efficiency because of flow favorable formed impeller

2.

Hohe Belastbarkeit aufgrund solider Wellen-Nabenverbindung

High rigidity with its solid shaft-hub connection

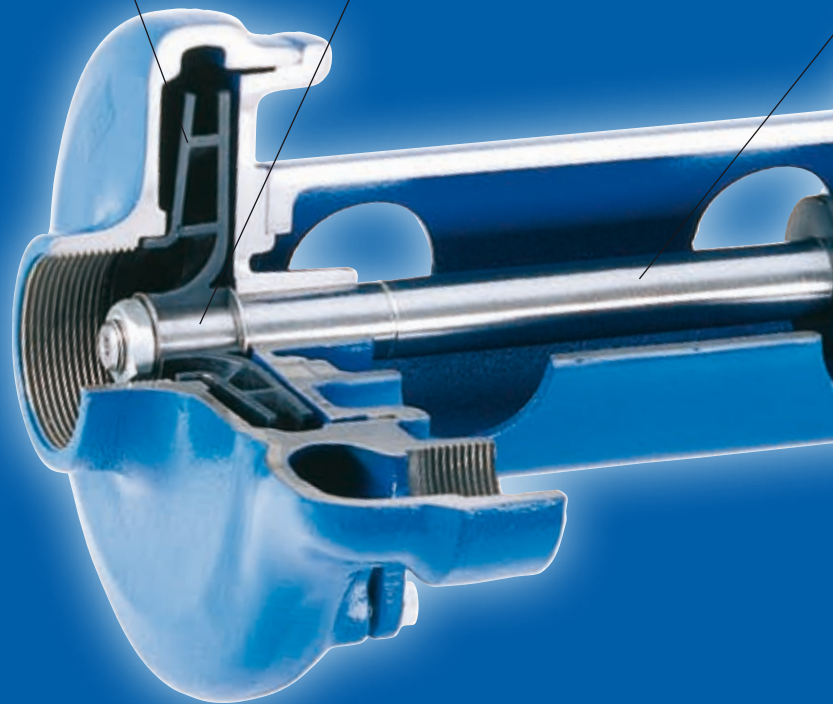

Einsatzbereiche

KNOLL-Kreiselpumpen sind Tauchpumpen. Sie werden auf drucklose Behälter montiert und tauchen in das Medium ein. Die Strömungsmaschinen werden hauptsächlich an Werkzeugmaschinen zur Förderung von Kühlmittelschmierstoffen (KSS) eingesetzt. Als Rückförderpumpen transportieren sie das Späne-/KSS-Gemisch auf Filter/Abscheider. Mit dem gereinigten KSS versorgen sie anschließend wieder die Maschinen. Dank solider und robuster Bauweise sind die KNOLL-Kühlmittelpumpen extrem belastbar und besitzen eine lange Lebensdauer.

Es gibt 5 unterschiedliche Bauarten:

Typ TG mit geschlossenem Laufrad

Für vorgereinigte KSS. Volumenstrom bis 1600 l/min, Druck bis 6 bar, Korngröße bis 3 mm.

Typ TGM mit geschlossenen Laufrädern

Für verschmutzte KSS. Volumenstrom bis 1100 l/min, Druck bis 5,5 bar, Korngröße bis 15 mm.

Typ TF mit Freistromlaufrad

Für verschmutzte KSS. Volumenstrom bis 1000 l/min, Druck bis 2,4 bar, Korngröße bis 30 mm.

Typ TS mit Schraubenlaufrad

Für verschmutzte und luftthaltige KSS. Volumenstrom bis

600 l/min, Druck bis 1,8 bar, Korngröße bis 15 mm.

Typ TSK mit kurzem Schraubenlaufrad

Für stark verschmutzte KSS mit abrasiven Spänen. Volumenstrom bis 1400 l/min, Druck bis 2,3 bar, Korngröße bis 20 mm.

Konstruktion

Bauart

- Vertikale Bauform
- Normalsaugend, dichtungslös, einstufig, mehrstufig
- Verlängerte, fliegend gelagerte Motorwelle mit Spritzring
- Druckstufen radial, nach oben abgewinkelt, Saugstutzen axial

Antrieb

Drehstrommotor IE 2

Bauart V 18, Schutzart IP 54, Isolierstoffklasse F

- 230 V (Δ) / 400 V (Y), 50 Hz, 2900 min⁻¹ | bis 3 kW
- 265 V (Δ) / 460 V (Y), 60 Hz, 3500 min⁻¹ |
- 400 V (Δ) / 690 V (Y), 50 Hz, 2900 min⁻¹ | ab 4 kW
- 460 V (Δ), 60 Hz, 3500 min⁻¹ |

3.

Trockenlaufsicherheit durch
fliegend gelagerte Welle

Safe of dry running because
of taper bore mounting

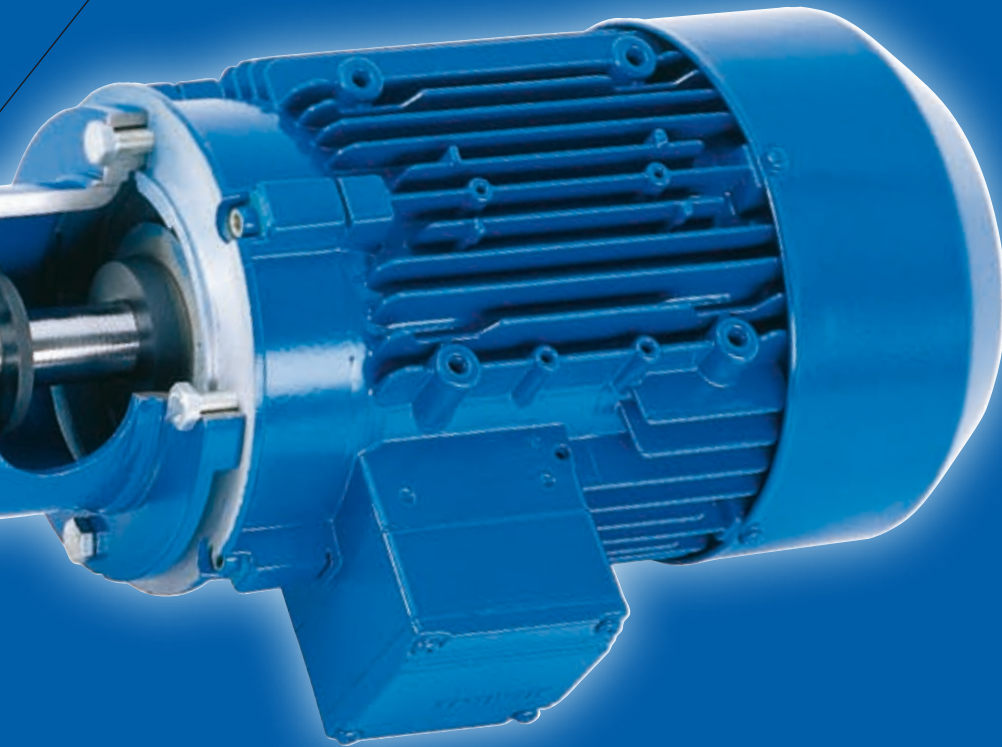

Areas of application

KNOLL centrifugal pumps are submersible pumps. They are mounted to non-pressurised containers and immerse into the medium. The flow machines are mainly used on machine tools for conveying coolants. As recirculation pumps, they transport the chip/coolant mixture to filters/separators. The cleaned coolant is then reused in the machines. Thanks to their sturdy and rugged construction, KNOLL coolant pumps are extremely durable and have a long service life.

There are 5 different types available:

Type TG with closed impeller

For precleaned coolant lubricant, volume flow up to 1600 l/min, pressure up to 6 bar, grain size up to 3 mm.

Type TGM with closed impellers

For dirt coolant lubricant, volume flow up to 1100 l/min, pressure up to 5.5 bar, grain size up to 15 mm.

Type TF with open impeller

For dirt coolant lubricant, volume flow up to 1000 l/min, pressure up to 2.4 bar, grain size up to 30 mm.

Type TS with helical impeller

For dirt and aerated coolant lubricant, volume flow up to 600 l/min, pressure up to 1,8 bar, grain size up to 15 mm.

Type TSK with short helical impeller

For very dirt coolant lubricant with abrasive chips, volume flow up to 1400 l/min, pressure up to 2.3 bar, grain size up to 20 mm.

Construction

Type

- Vertical design
- Normal suction, without sealing, single stage, multi stage
- Extended taper bore mounted motor axle with centrifuge ring
- Pressure connection is radial and bent upwards, suction connection is axial

Drive

Three-phase motor IE 2

Type V 18, protection IP 54, insulated material class F

- 230 V (Δ) / 400 V (Y), 50 Hz, 2900 min⁻¹ | up to 3 kW
- 265 V (Δ) / 460 V (Y), 60 Hz, 3500 min⁻¹ |
- 400 V (Δ) / 690 V (Y), 50 Hz, 2900 min⁻¹ | from 4 kW
- 460 V (Δ), 60 Hz, 3500 min⁻¹ |

Reinmediumpumpen Typ TG
Pure medium pumps Typ TG

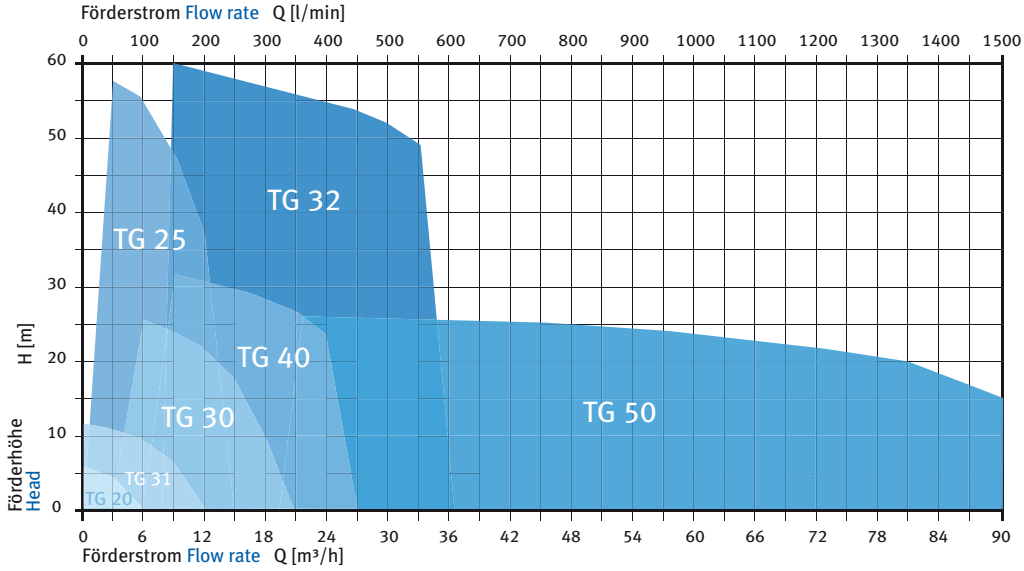

Schmutzmediumpumpen mehrstufig Typ TGM
Dirt medium pumps multi stage Typ TGM

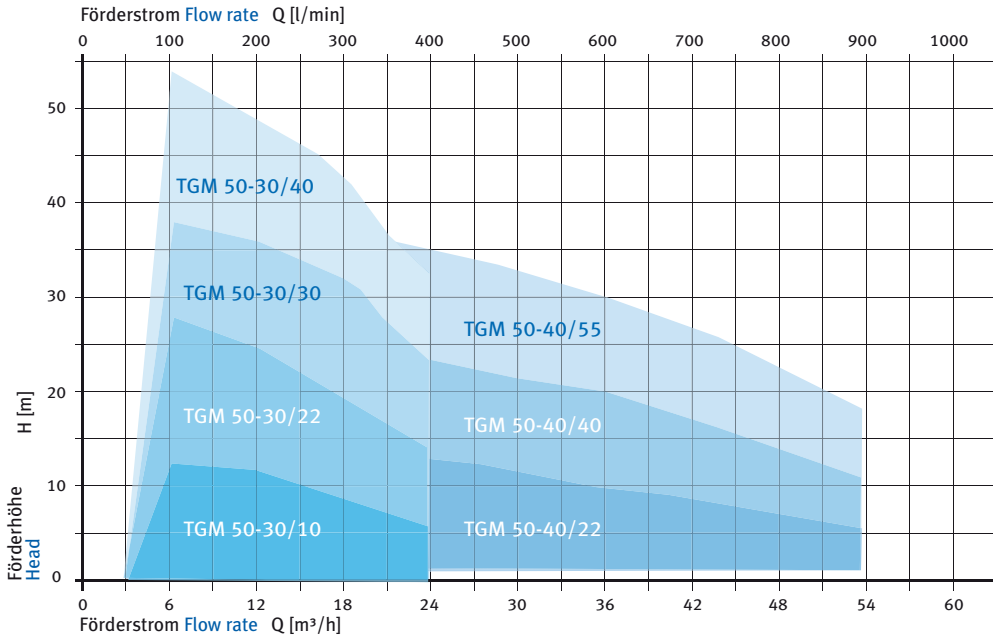

Schmutzmediumpumpen Typ TF, TS, TSK
Dirt medium pumps Typ TF, TS, TSK

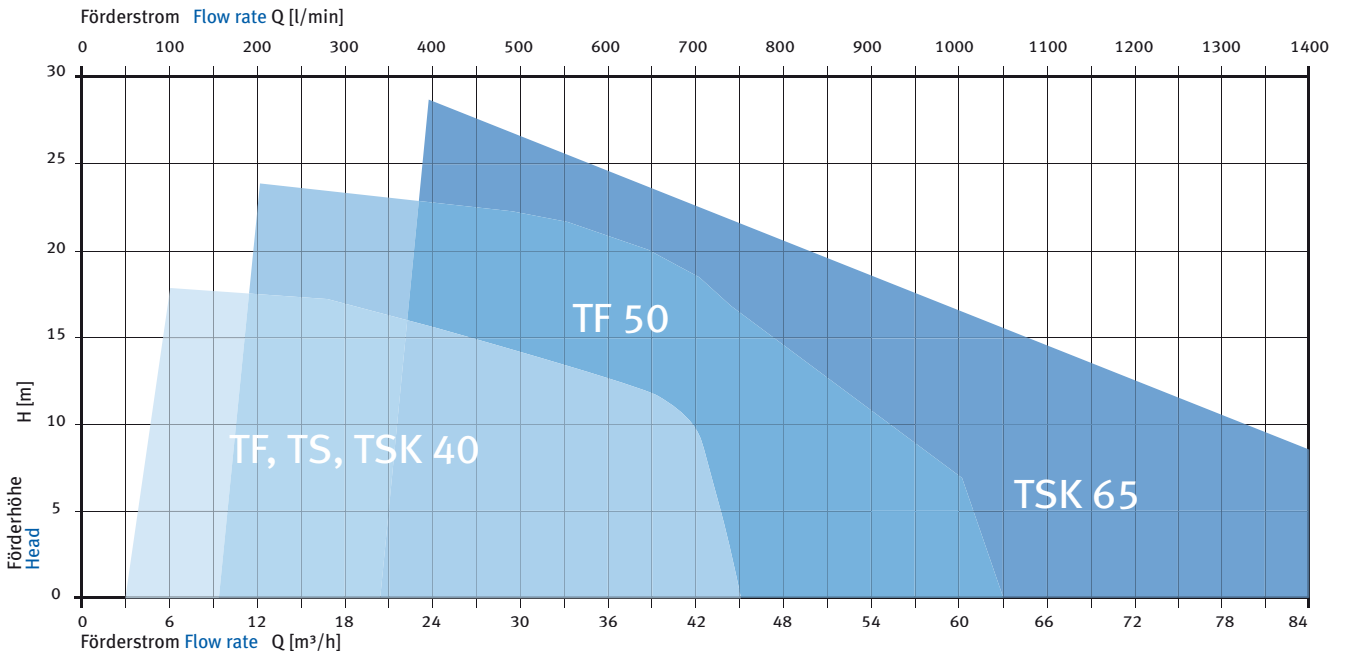

TG 20

Nenn Drehzahl /
Nominal rotation speed **2900 min⁻¹ @ 50 Hz**

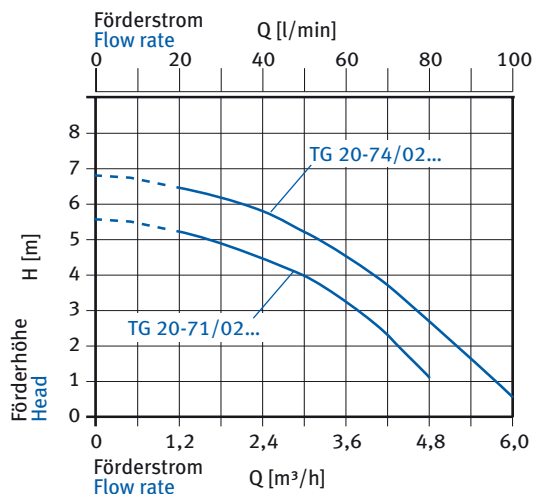

Typ/Type	T (mm)	H (mm)	G (mm)	Gewicht Weight (kg)	Motorleistung Motor power (kW)
TG 20-71/02 220	220	181	120	6,8	0,2
TG 20-74/02 220	220	181	120	6,8	0,2
TG 20-71/02 350	350	181	120	7,3	0,2
TG 20-74/02 350	350	181	120	7,3	0,2

Nenn Drehzahl /
Nominal rotation speed **3500 min⁻¹ @ 60 Hz**

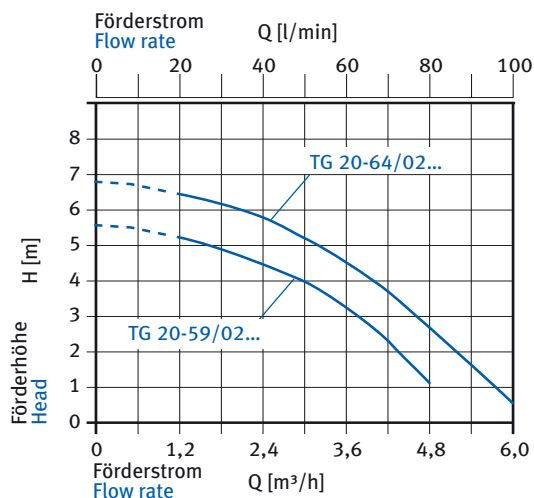

Typ/Type	T (mm)	H (mm)	G (mm)	Gewicht Weight (kg)	Motorleistung Motor power (kW)
TG 20-59/02 220	220	181	120	6,8	0,2
TG 20-64/02 220	220	181	120	6,8	0,2
TG 20-59/02 350	350	181	120	7,3	0,2
TG 20-64/02 350	350	181	120	7,3	0,2

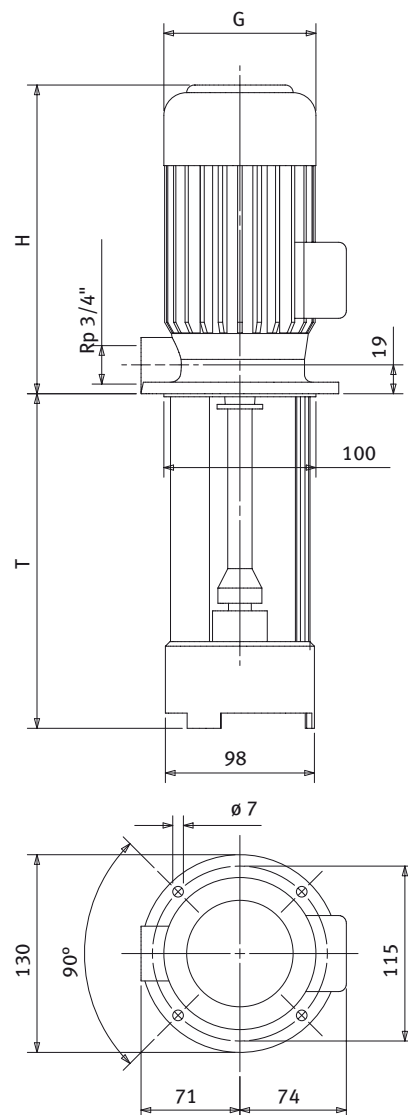

Tauchpumpe — TG 20-71/02 220
 Laufradform —
 Baugröße —
 Laufrad-Index —
 Motorleistung x 10 —
 Eintauchtiefe in mm —

Submerged pump — TG 20-71/02 220
 Form of impeller —
 Pump size —
 Impeller-index —
 Motor power x 10 —
 Depth of immersion in mm —

Max. Korngröße: 1 mm
 Laufrad-Werkstoff: GJL-200 (GG 20)
 Kennlinien für $\nu = 1 \text{ mm}^2/\text{s}$

Max. grain size: 1 mm
 Impeller material: GJL-200 (GG 20)
 Characteristic lines for $\nu = 1 \text{ mm}^2/\text{s}$

TG 25

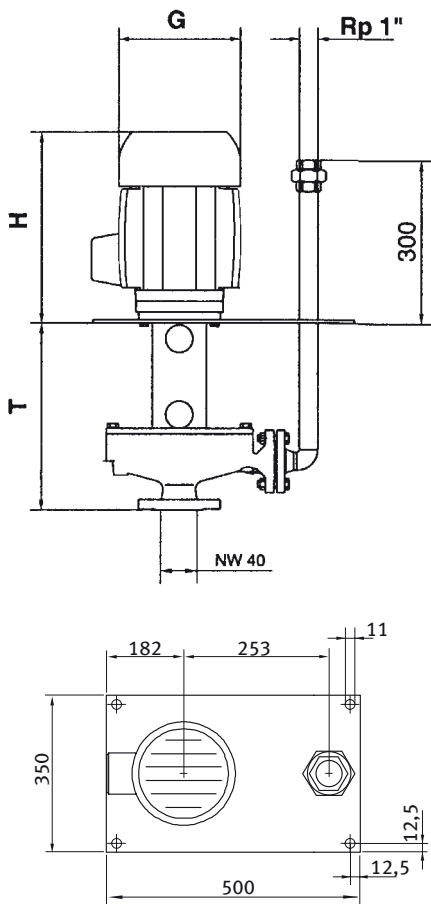

Typ/Type	T (mm)	H (mm)	G (mm)	Gewicht Weight (kg)	Motorleistung Motor power (kW)
TG 25-../22 345	345	320	180	47	2,2
TG 25-../30 345	345	350	200	49	3,0
TG 25-../22 590	590	320	180	51	2,2
TG 25-../30 590	590	350	200	53	3,0

Beispiel: Laufrad- \varnothing = 158 \rightarrow TG 25-58/22 345

Example: Impeller- \varnothing = 158 \rightarrow TG 25-58/22 345

Tauchpumpe — TG 25-58/22 345
 Laufradform —
 Baugröße —
 Laufrad-Index —
 Motorleistung x 10 —
 Eintauchtiefe in mm —

Submerged pump — TG 25-58/22 345
 Form of impeller —
 Pump size —
 Impeller-index —
 Motor power x 10 —
 Depth of immersion in mm —

Nenndrehzahl / Nominal rotation speed 2900 min⁻¹ @ 50 Hz

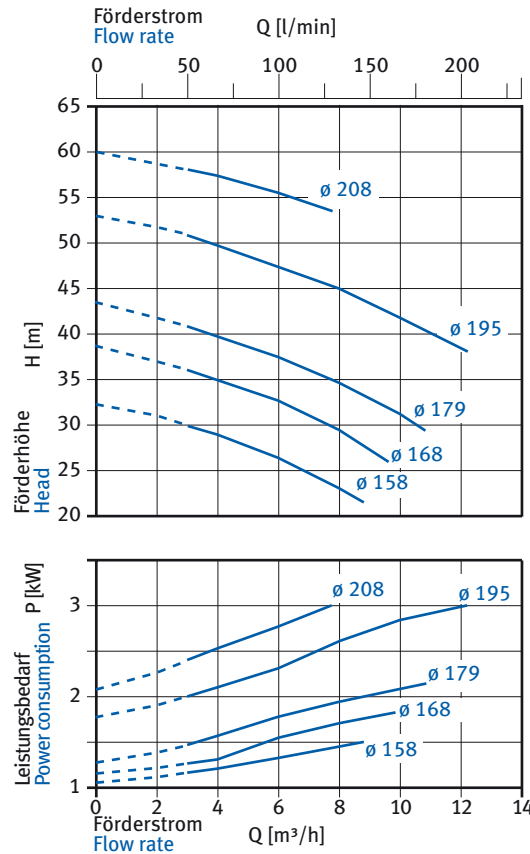

Nenndrehzahl / Nominal rotation speed 3500 min⁻¹ @ 60 Hz

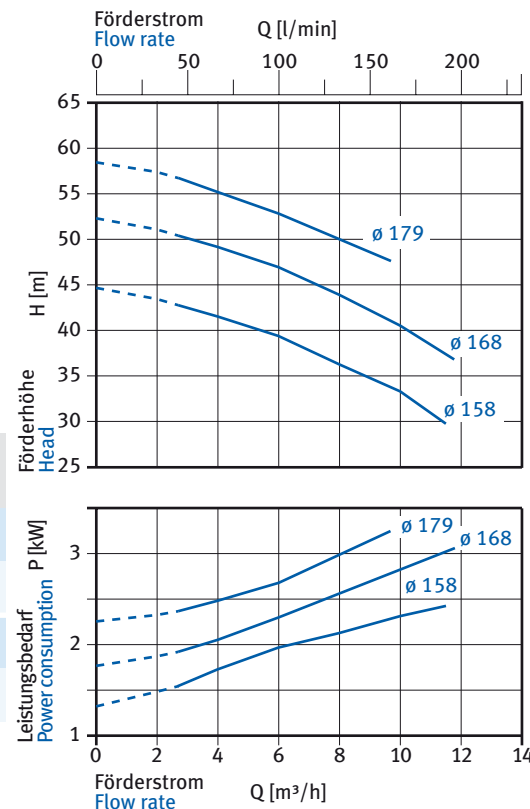

Max. Korngröße: 1 mm
 Laufrad-Werkstoff: GJL-250 (GG 25)
 Kennlinien für $\nu = 1 \text{ mm}^2/\text{s}$

Max. grain size: 1 mm
 Impeller material: GJL-250 (GG 25)
 Characteristic lines for $\nu = 1 \text{ mm}^2/\text{s}$

TG 30

Nenn Drehzahl /
Nominal rotation speed **2900 min⁻¹ @ 50 Hz**

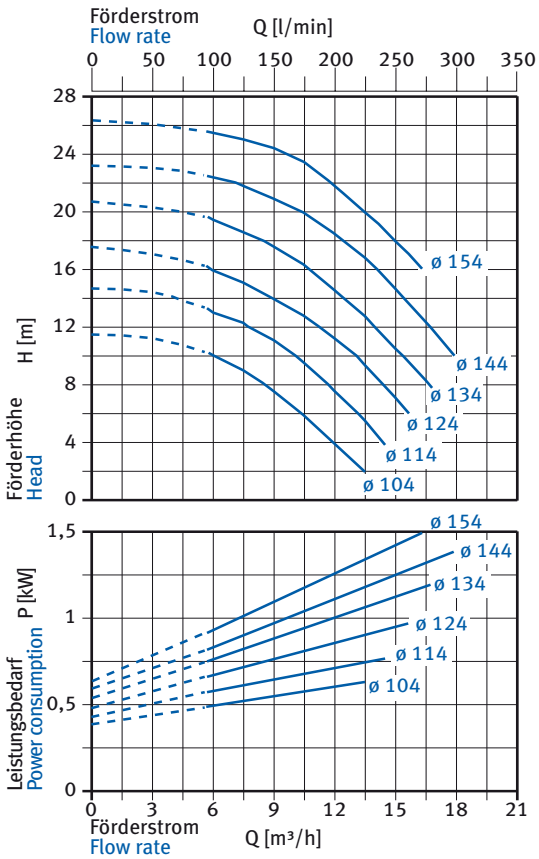

Nenn Drehzahl /
Nominal rotation speed **3500 min⁻¹ @ 60 Hz**

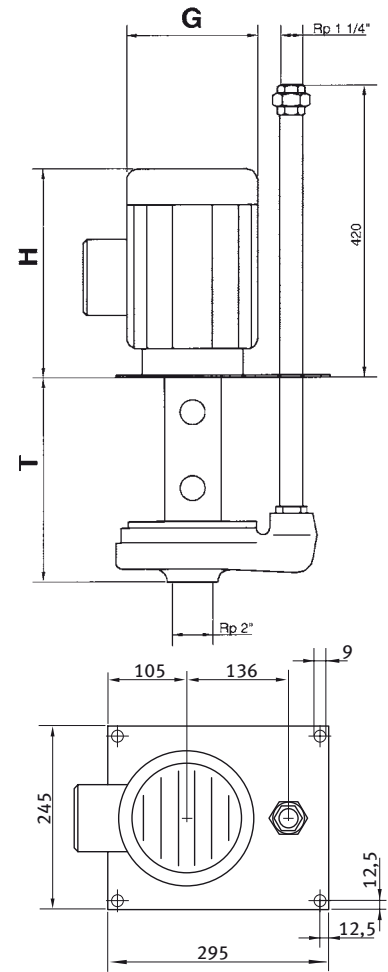
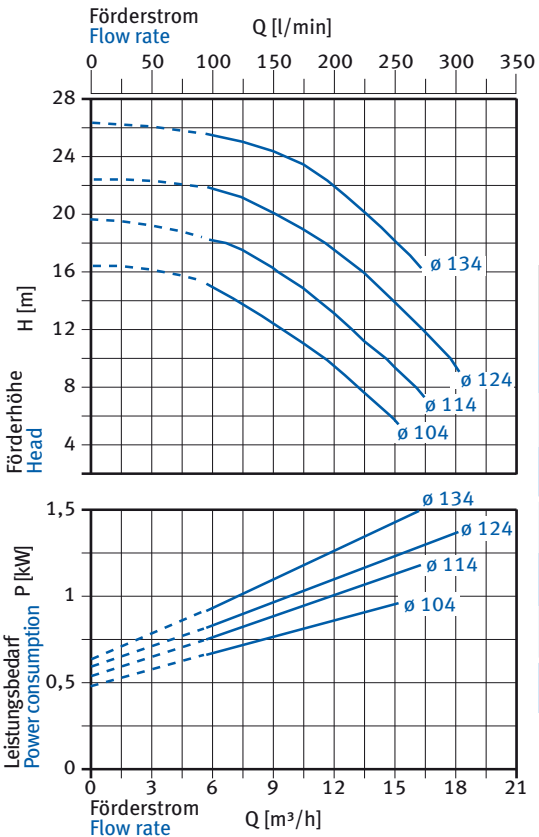

Typ/Type	T (mm)	H (mm)	G (mm)	Gewicht Weight (kg)	Motorleistung Motor power (kW)
TG 30-../07 285	285	270	160	23	0,75
TG 30-../11 285	285	270	160	24	1,1
TG 30-../15 285	285	290	180	27	1,5
TG 30-../07 533	533	270	160	30	0,75
TG 30-../11 533	533	270	160	31	1,1
TG 30-../15 533	533	290	180	34	1,5
TG 30-../15 781	781	290	180	41	1,5

Beispiel: Laufrad-Ø = 154 → TG 30-54/15 285

Example: Impeller-Ø = 154 → TG 30-54/15 285

Tauchpumpe — TG 30-54/15 285
Laufradform —
Baugröße —
Laufrad-Index —
Motorleistung x 10 —
Eintauchtiefe in mm —

Submerged pump — TG 30-54/15 285
Form of impeller —
Pump size —
Impeller-index —
Motor power x 10 —
Depth of immersion in mm —

Max. Korngröße: 1 mm
Laufrad-Werkstoff: POM
Kennlinien für $v = 1 \text{ mm}^2/\text{s}$

Max. grain size: 1 mm
Impeller material: POM
Characteristic lines for $v = 1 \text{ mm}^2/\text{s}$

TG 31

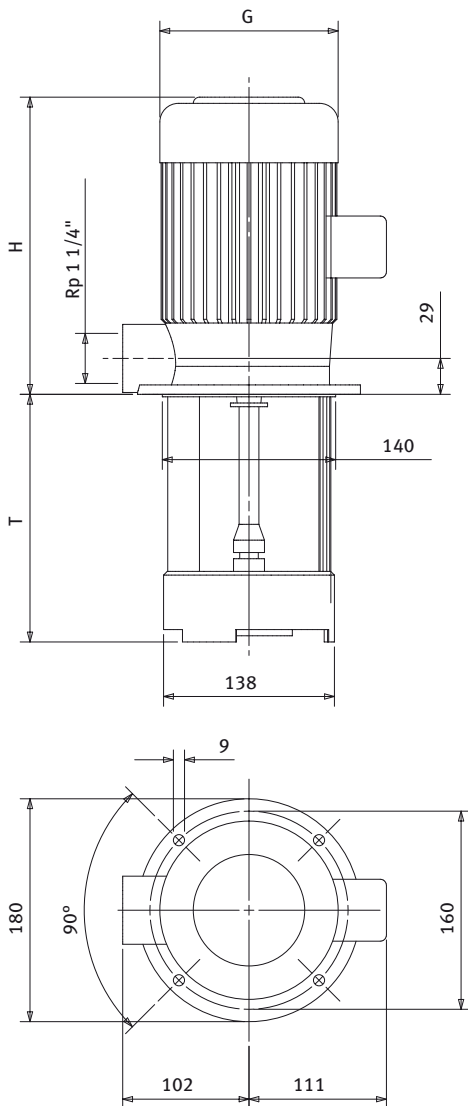

Nenn Drehzahl /
Nominal rotation speed 2900 min⁻¹ @ 50 Hz

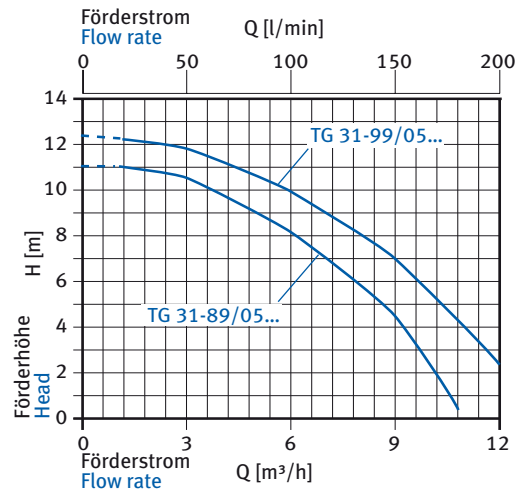

Typ/Type	T (mm)	H (mm)	G (mm)	Gewicht Weight (kg)	Motorleistung Motor power (kW)
TG 31-89/05 200	200	240	140	13,7	0,55
TG 31-99/05 200	200	240	140	13,7	0,55
TG 31-89/05 350	350	240	140	14,8	0,55
TG 31-99/05 350	350	240	140	14,8	0,55
TG 31-89/05 550	550	240	140	16,3	0,55
TG 31-99/05 550	550	240	140	16,3	0,55

Nenn Drehzahl /
Nominal rotation speed 3500 min⁻¹ @ 60 Hz

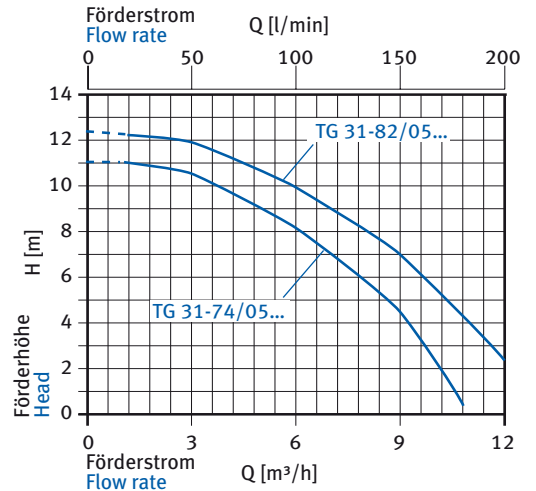

Typ/Type	T (mm)	H (mm)	G (mm)	Gewicht Weight (kg)	Motorleistung Motor power (kW)
TG 31-74/05 200	200	240	140	13,7	0,55
TG 31-82/05 200	200	240	140	13,7	0,55
TG 31-74/05 350	350	240	140	14,8	0,55
TG 31-82/05 350	350	240	140	14,8	0,55
TG 31-74/05 550	550	240	140	16,3	0,55
TG 31-82/05 550	550	240	140	16,3	0,55

Tauchpumpe — TG 31-89/05 200
 Laufradform —
 Baugröße —
 Laufrad-Index —
 Motorleistung x 10 —
 Eintauchtiefe in mm —

Submerged pump — TG 31-89/05 200
 Form of impeller —
 Pump size —
 Impeller-index —
 Motor power x 10 —
 Depth of immersion in mm —

Max. Korngröße: 1 mm
 Laufrad-Werkstoff: GJL-200 (GG 20)
 Kennlinien für $\nu = 1 \text{ mm}^2/\text{s}$

Max. grain size: 1 mm
 Impeller material: GJL-200 (GG 20)
 Characteristic lines for $\nu = 1 \text{ mm}^2/\text{s}$

TG 32

Nenn Drehzahl /
Nominal rotation speed 2900 min⁻¹ @ 50 Hz

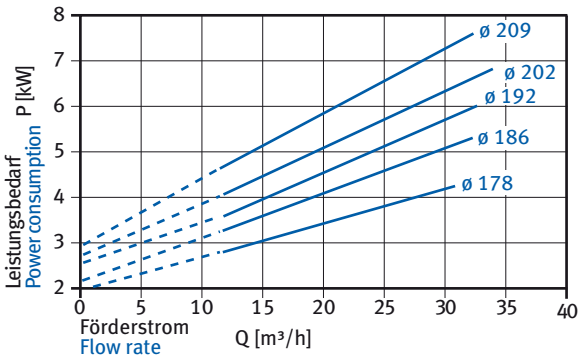
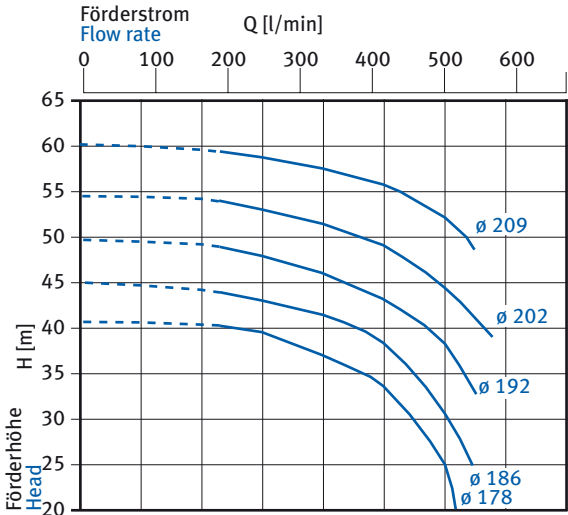

Nenn Drehzahl /
Nominal rotation speed 3500 min⁻¹ @ 60 Hz

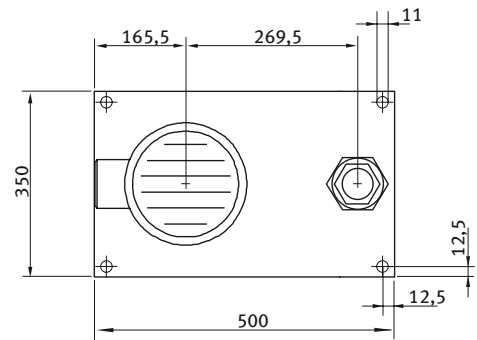
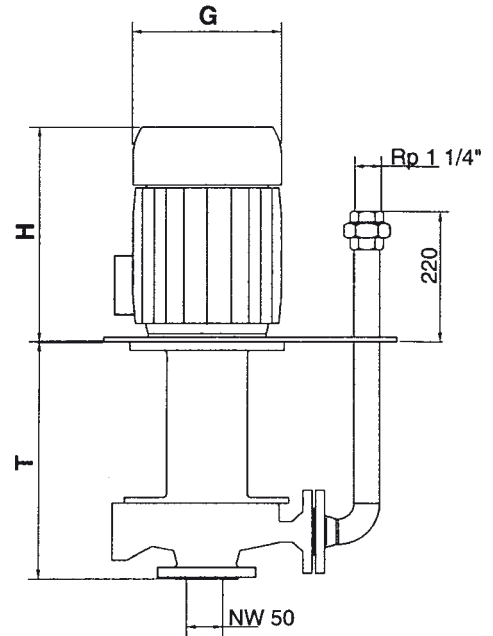
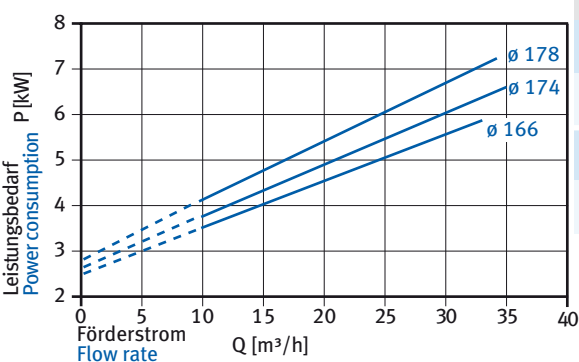
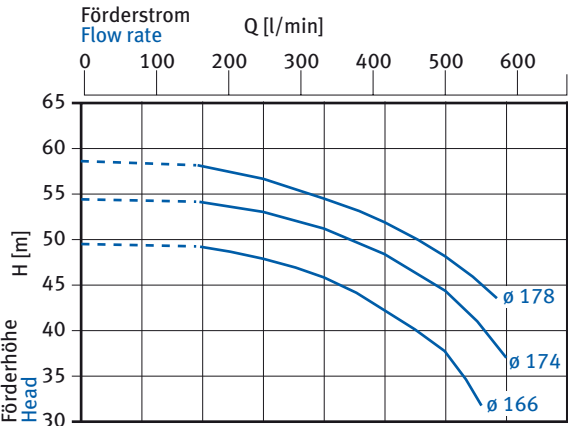

Typ/Type	T (mm)	H (mm)	G (mm)	Gewicht/Weight (kg)	Motorleistung/Motor power (kW)
TG 32-../55 400	400	370	252	100	5,5
TG 32-../75 400	400	370	252	106	7,5
TG 32-../55 700	700	370	252	127	5,5
TG 32-../75 700	700	370	252	133	7,5

Beispiel: Laufrad-Ø = 178 → TG 32-78/75 700

Example: Impeller-Ø = 178 → TG 32-78/75 700

Tauchpumpe — TG 32-78/75 700
 Laufradform —
 Baugröße —
 Laufrad-Index —
 Motorleistung x 10 —
 Eintauchtiefe in mm —

Submerged pump — TG 32-78/75 700
 Form of impeller —
 Pump size —
 Impeller-index —
 Motor power x 10 —
 Depth of immersion in mm —

Max. Korngröße: 2 mm
 Laufrad-Werkstoff: GJL-250 (GG 25)
 Kennlinien für $\nu = 1 \text{ mm}^2/\text{s}$

Max. grain size: 2 mm
 Impeller material: GJL-250 (GG 25)
 Characteristic lines for $\nu = 1 \text{ mm}^2/\text{s}$

TG 40

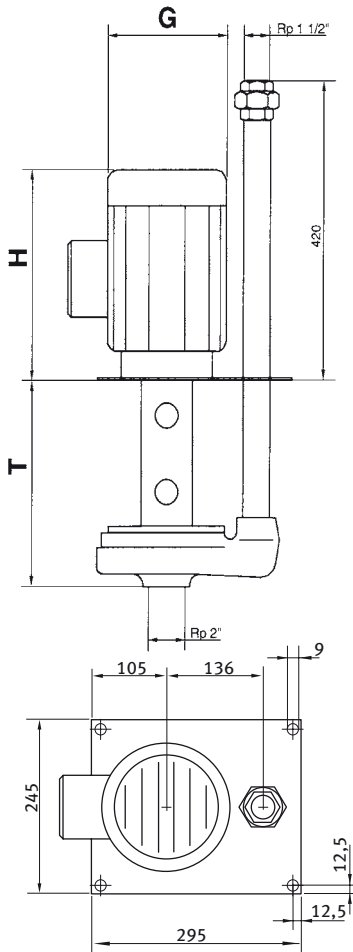

Typ/Type	T (mm)	H (mm)	G (mm)	Gewicht Weight (kg)	Motorleistung Motor power (kW)
TG 40-../11 285	285	270	160	25	1,1
TG 40-../15 285	285	290	180	28	1,5
TG 40-../22 285	285	320	180	31	2,2
TG 40-../30 285	285	350	200	35	3,0
TG 40-../11 533	533	270	160	32	1,1
TG 40-../15 533	533	290	180	35	1,5
TG 40-../22 533	533	320	180	38	2,2
TG 40-../30 533	533	350	200	42	3,0
TG 40-../15 781	781	290	180	42	1,5
TG 40-../22 781	781	320	180	45	2,2
TG 40-../30 781	781	350	200	49	3,0

Beispiel: Laufrad-Ø = 155 → TG 40-55/30 285

Example: Impeller-Ø = 155 → TG 40-55/30 285

Tauchpumpe — TG 40-55/30 285
 Laufradform —
 Baugröße —
 Laufrad-Index —
 Motorleistung x 10 —
 Eintauchtiefe in mm —

Submerged pump — TG 40-55/30 285
 Form of impeller —
 Pump size —
 Impeller-index —
 Motor power x 10 —
 Depth of immersion in mm —

Nenn Drehzahl / Nominal rotation speed 2900 min⁻¹ @ 50 Hz

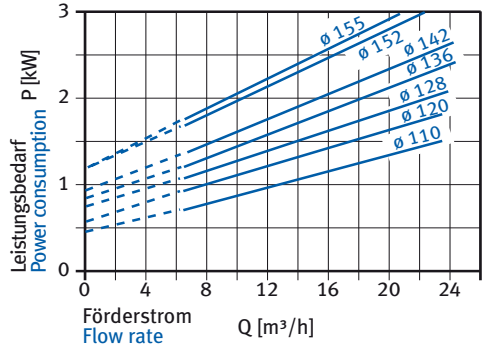
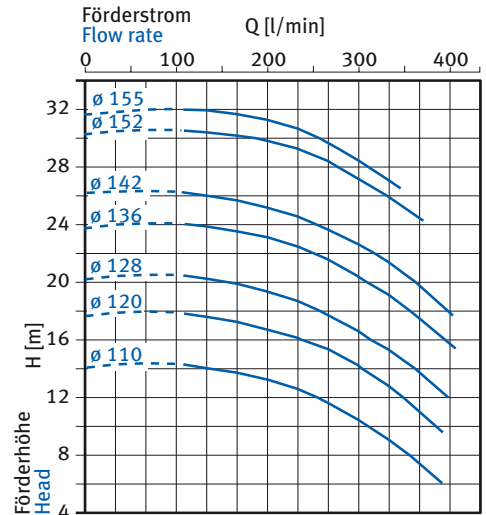

Nenn Drehzahl / Nominal rotation speed 3500 min⁻¹ @ 60 Hz

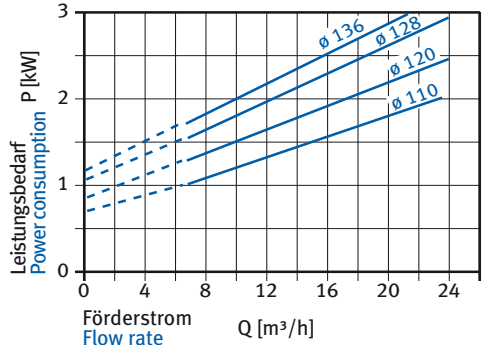
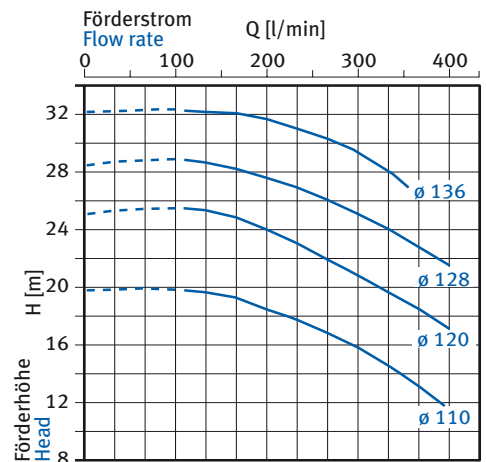

Max. Korngröße: 3 mm
 Laufrad-Werkstoff: POM/GJL-250 (GG 25)
 Kennlinien für $\nu = 1 \text{ mm}^2/\text{s}$

Max. grain size: 3 mm
 Impeller material: POM/GJL-250 (GG 25)
 Characteristic lines for $\nu = 1 \text{ mm}^2/\text{s}$

TG 50

Nennzahl /
Nominal rotation speed 2900 min⁻¹ @ 50 Hz

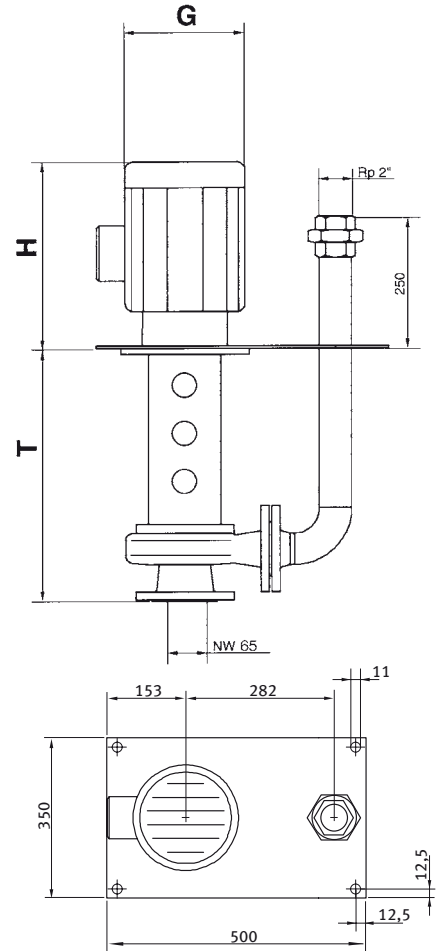
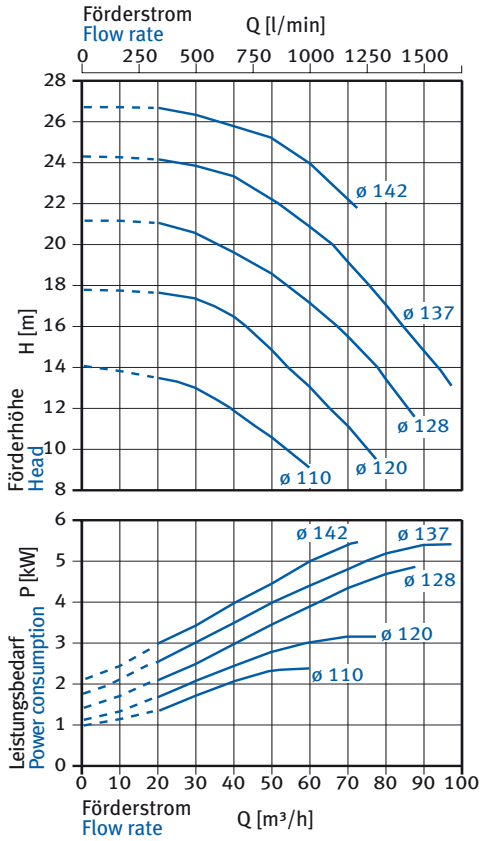

Nennzahl /
Nominal rotation speed 3500 min⁻¹ @ 60 Hz

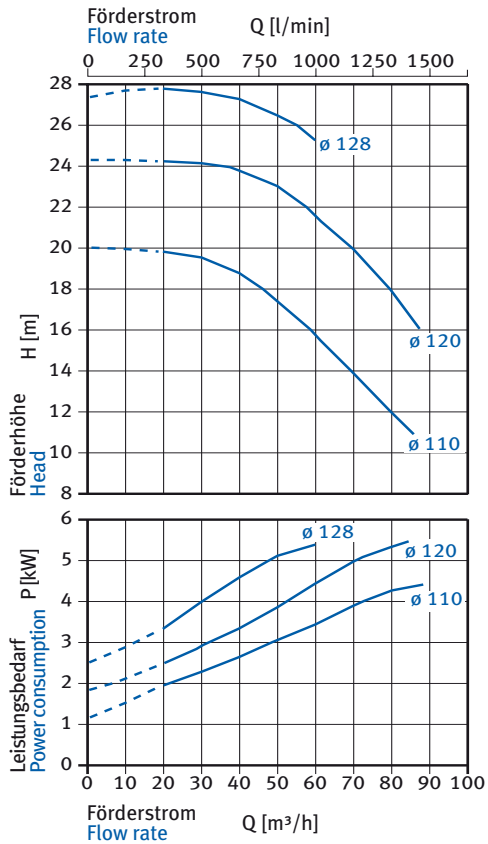

Typ/Type	T (mm)	H (mm)	G (mm)	Gewicht/Weight (kg)	Motorleistung/Motor power (kW)
TG 50-../40 480	480	355	224	68	4,0
TG 50-../55 480	480	355	224	78	5,5
TG 50-../40 840	840	355	224	75	4,0
TG 50-../55 840	840	355	224	85	5,5

Beispiel: Laufrad-Ø = 128 → TG 50-28/55 480

Example: Impeller-Ø = 128 → TG 50-28/55 480

Tauchpumpe — TG 50-28/55 480
Laufradform —
Baugröße —
Laufrad-Index —
Motorleistung x 10 —
Eintauchtiefe in mm —

Submerged pump — TG 50-28/55 480
Form of impeller —
Pump size —
Impeller-index —
Motor power x 10 —
Depth of immersion in mm —

Max. Korngröße: 15 mm
Laufrad-Werkstoff: GJL-250 (GG 25)
Kennlinien für $\nu = 1 \text{ mm}^2/\text{s}$

Max. grain size: 15 mm
Impeller material: GJL-250 (GG 25)
Characteristic lines for $\nu = 1 \text{ mm}^2/\text{s}$

TGM 50-30

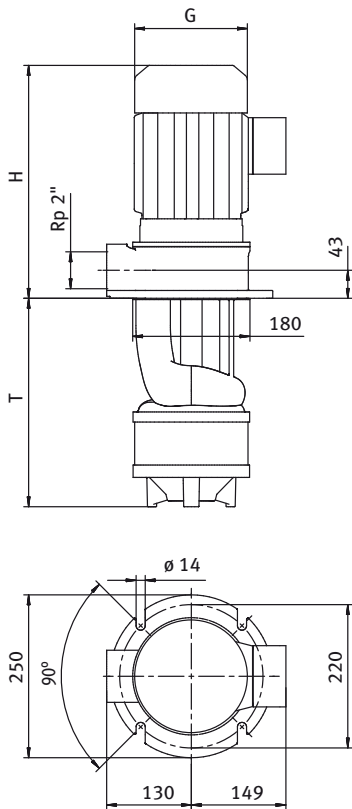

Nenn Drehzahl /
Nominal rotation speed 2900 min⁻¹ @ 50 Hz

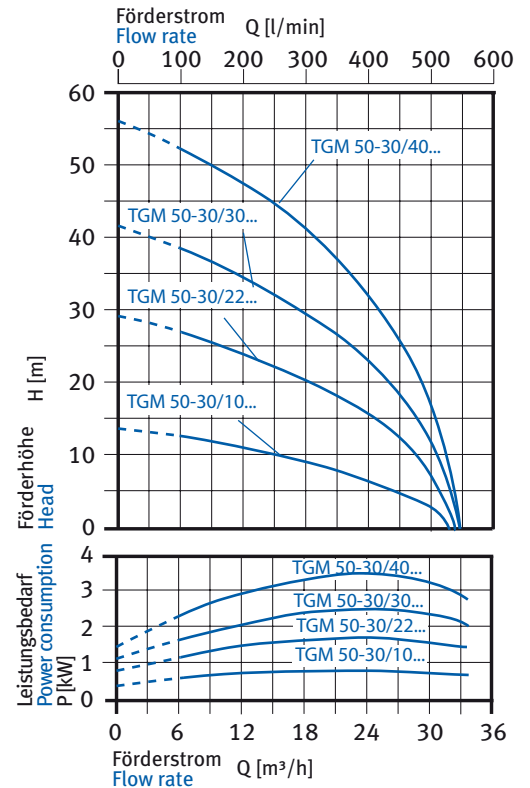

Typ/Type	T (mm)	H (mm)	G (mm)	Gewicht/Weight (kg)	Motorleistung/Motor power (kW)
TGM 50-../10 250	250	305	140	30	1,0
TGM 50-../10 320	320	305	140	32	1,0
TGM 50-../10 450	450	305	140	34	1,0
TGM 50-../10 550	550	305	140	36	1,0
TGM 50-../22 320	320	348	176	42	2,2
TGM 50-../22 390	390	348	176	44	2,2
TGM 50-../22 520	520	348	176	46	2,2
TGM 50-../22 620	620	348	176	48	2,2
TGM 50-../30 390	390	348	176	53	3,0
TGM 50-../30 460	460	348	176	55	3,0
TGM 50-../30 590	590	348	176	56	3,0
TGM 50-../40 460	460	380	196	62	4,0
TGM 50-../40 530	530	380	196	64	4,0
TGM 50-../40 660	660	380	196	65	4,0

Nenn Drehzahl /
Nominal rotation speed 3500 min⁻¹ @ 60 Hz

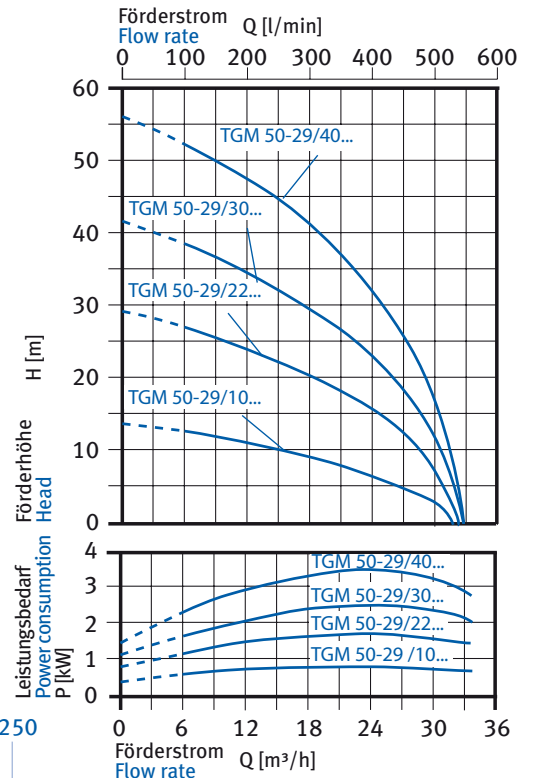

Max. Spanfracht: 1 g/l
Max. Korngröße: 15 mm
Lauf rad-Werkstoff: GJL-200 (GG 20)
Kennlinien für $\nu = 1 \text{ mm}^2/\text{s}$

Max. grain load: 1g/l
Max. grain size: 15 mm
Impeller material: GJL-200 (GG 20)
Characteristic lines for $\nu = 1 \text{ mm}^2/\text{s}$

Tauchpumpe — TGM 50-30/10 250
Lauf rad-Form —
Baugröße —
Lauf rad-Index —
Motorleistung x 10 —
Eintauchtiefe in mm —

Submerged pump — TGM 50-30/10 250
Form of impeller —
Pump size —
Impeller-index —
Motor power x 10 —
Depth of immersion in mm —

TGM 50-40

Nennzahl /
Nominal rotation speed 2900 min⁻¹ @ 50 Hz

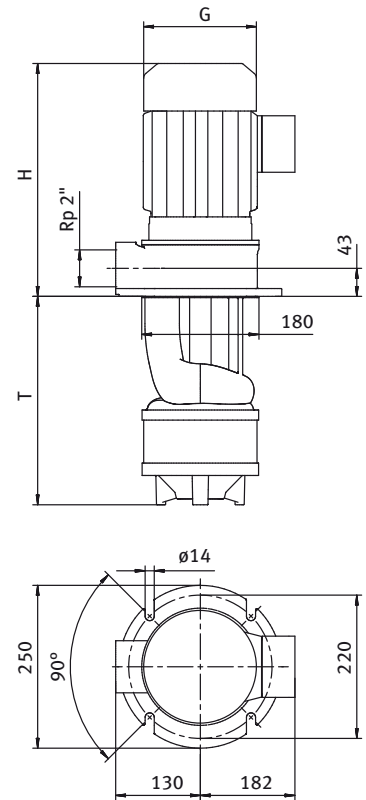
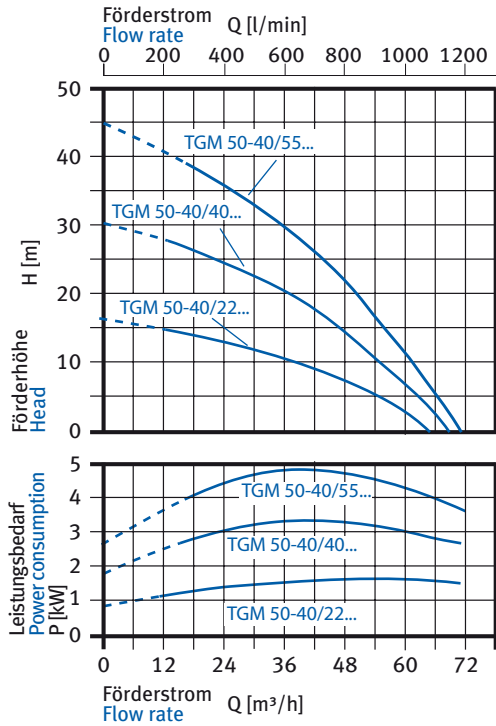

Nennzahl /
Nominal rotation speed 3500 min⁻¹ @ 60 Hz

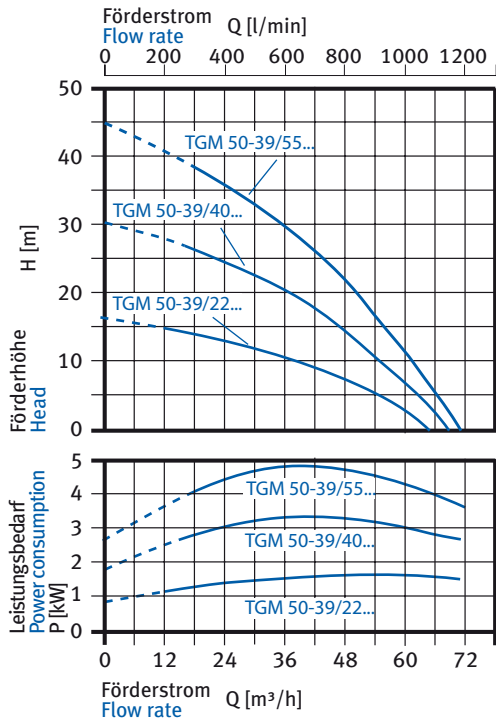

Typ/Type	T (mm)	H (mm)	G (mm)	Gewicht (kg) Weight	Motorleistung (kW) Motor power
TGM 50-.../22 250	250	348	176	36	2,2
TGM 50-.../22 320	320	348	176	38	2,2
TGM 50-.../22 450	450	348	176	39	2,2
TGM 50-.../22 550	550	348	176	40	2,2
TGM 50-.../40 320	320	358	176	46	4,0
TGM 50-.../40 390	390	358	176	48	4,0
TGM 50-.../40 520	520	358	176	50	4,0
TGM 50-.../40 620	620	358	176	52	4,0
TGM 50-.../55 390	390	482	270	54	5,5
TGM 50-.../55 460	460	482	270	56	5,5
TGM 50-.../55 590	590	482	270	58	5,5

Tauchpumpe — TGM 50-40/22 250 Submerged pump — TGM 50-40/22 250
 Laufradform Form of impeller
 Baugröße Pump size
 Laufrad-Index Impeller-index
 Motorleistung x 10 Motor power x 10
 Eintauchtiefe in mm Depth of immersion in mm

Max. Spanfracht: 1 g/l
 Max. Korngröße: 15 mm
 Laufrad-Werkstoff: GJL-200 (GG 20)
 Kennlinien für $v = 1 \text{ mm}^2/\text{s}$

Max. grain load: 1 g/l
 Max. grain size: 15 mm
 Impeller material: GJL-200 (GG 20)
 Characteristic lines for $v = 1 \text{ mm}^2/\text{s}$

TF40

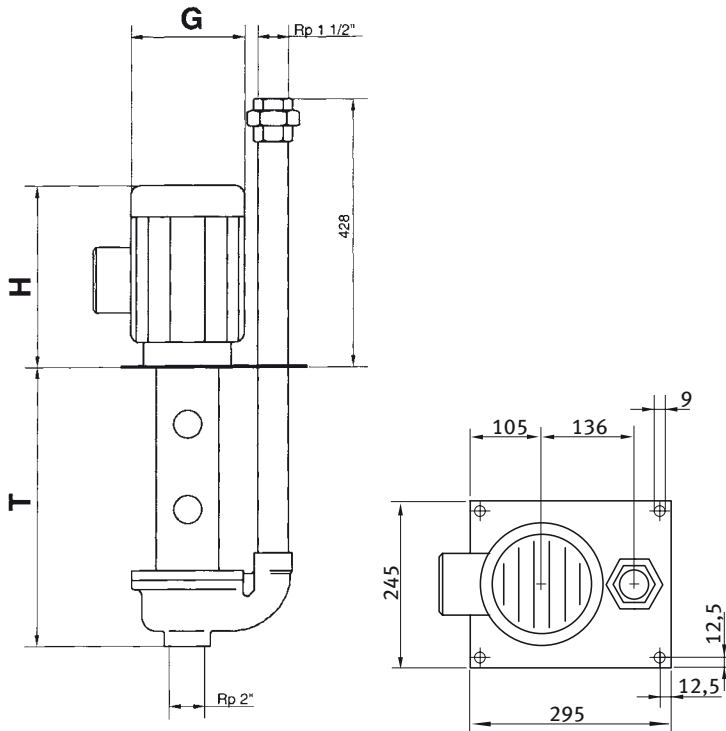

Typ/Type	T (mm)	H (mm)	G (mm)	Gewicht/Weight (kg)	Motorleistung/Motor power (kW)
TF 40-../07 330	330	270	160	26	0,75
TF 40-../11 330	330	270	160	27	1,1
TF 40-../15 330	330	290	180	30	1,5
TF 40-../22 330	330	320	180	33	2,2
TF 40-../30 330	330	350	200	37	3,0
TF 40-../07 578	578	270	160	33	0,75
TF 40-../11 578	578	270	160	34	1,1
TF 40-../15 578	578	290	180	37	1,5
TF 40-../22 578	578	320	180	40	2,2
TF 40-../30 578	578	350	200	44	3,0
TF 40-../15 826	826	290	180	44	1,5
TF 40-../22 826	826	320	180	47	2,2
TF 40-../30 826	826	350	200	51	3,0

Beispiel: Laufrad-Ø = 115 → TF 40-15/30 330

Example: Impeller-Ø = 115 → TF 40-15/30 330

Max. Spanfracht: 2 g/l
 Max. Korngröße: 15 mm
 Laufrad-Werkstoff: POM/GJL-250 (GG 25)
 Kennlinien für $\nu = 1 \text{ mm}^2/\text{s}$

Max. grain load: 2 g/l
 Max. grain size: 15 mm
 Impeller material: POM/GJL-250 (GG 25)
 Characteristic lines for $\nu = 1 \text{ mm}^2/\text{s}$

Tauchpumpe — TF 40-15/30 330
 Laufradform —
 Baugröße —
 Laufrad-Index —
 Motorleistung x 10 —
 Eintauchtiefe in mm —

Submerged pump — TF 40-15/30 330
 Form of impeller —
 Pump size —
 Impeller-index —
 Motor power x 10 —
 Depth of immersion in mm —

Nenn Drehzahl / Nominal rotation speed 2900 min⁻¹ @ 50 Hz

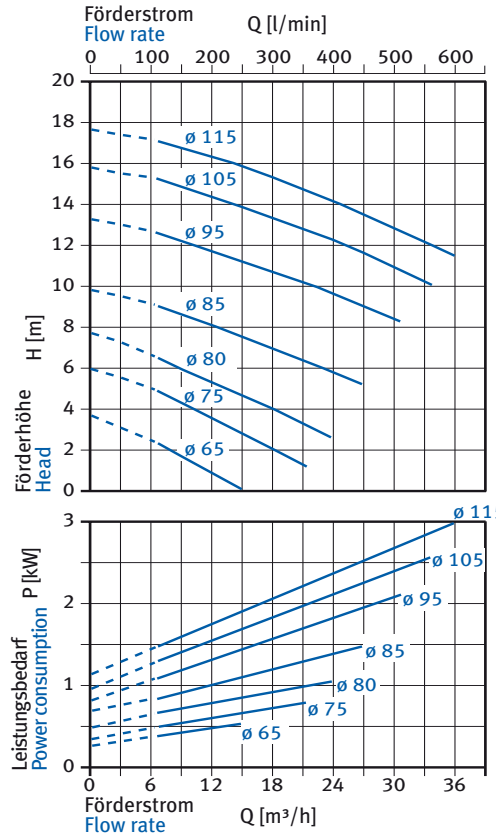

Nenn Drehzahl / Nominal rotation speed 3500 min⁻¹ @ 60 Hz

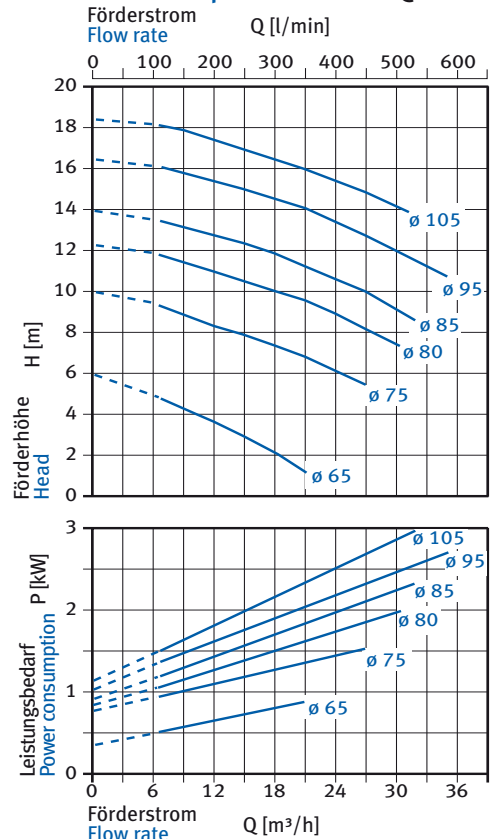

Nennzahl /
Nominal rotation speed 2900 min⁻¹ @ 50 Hz

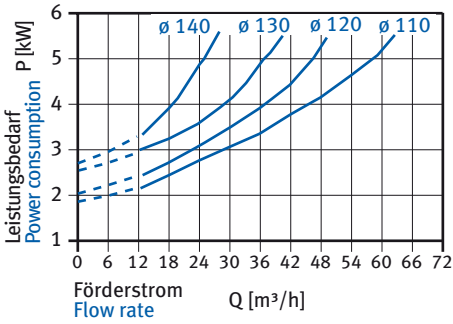
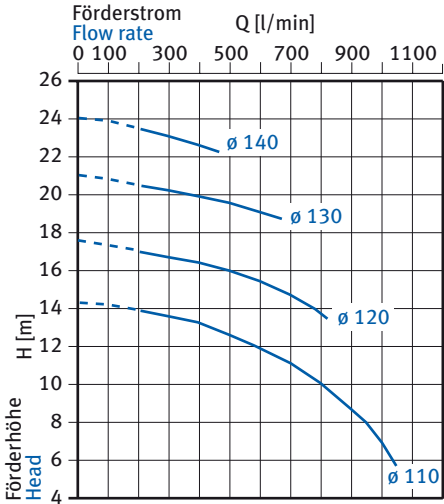

Nennzahl /
Nominal rotation speed 3500 min⁻¹ @ 60 Hz

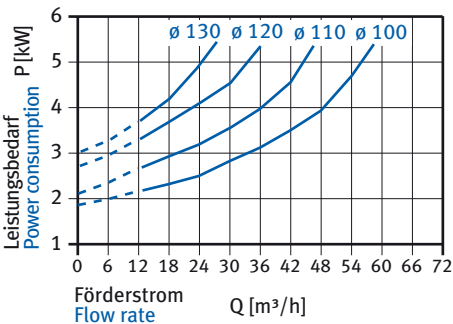
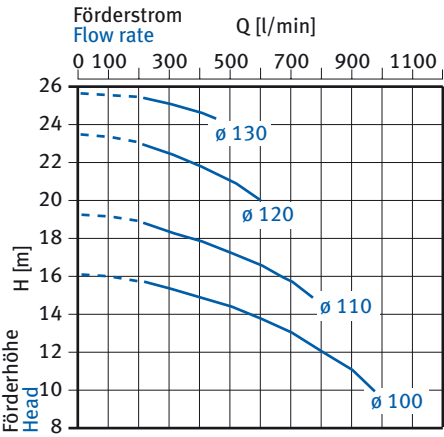

TF 50

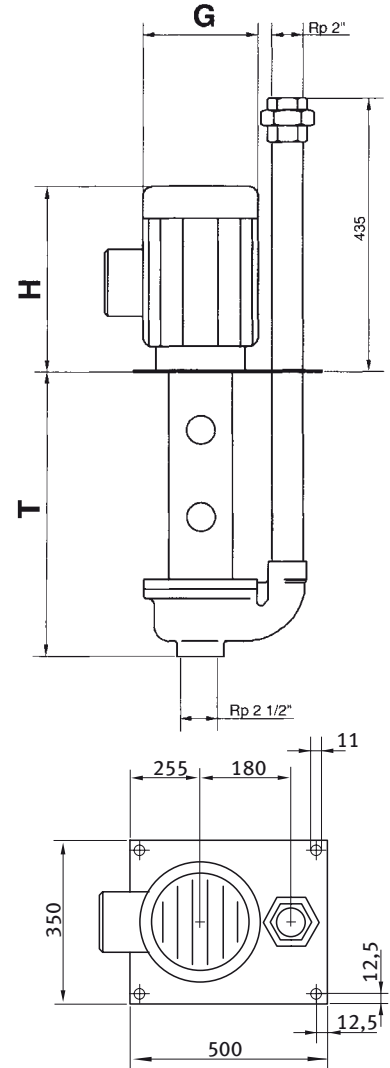

Typ/Type	T (mm)	H (mm)	G (mm)	Gewicht/Weight (kg)	Motorleistung/Motor power (kW)
TF 50-../40 488	488	355	224	68	4,0
TF 50-../55 488	488	355	224	78	5,5
TF 50-../40 848	848	355	224	75	4,0
TF 50-../55 848	848	355	224	85	5,5

Beispiel: Laufrad-Ø = 140 → TF 50-40/55 488

Example: Impeller-Ø = 140 → TF 50-40/55 488

Tauchpumpe — TF 50-40/55 488
 Laufradform
 Baugröße
 Laufrad-Index
 Motorleistung x 10
 Eintauchtiefe in mm

Submerged pump — TF 50-40/55 488
 Form of impeller
 Pump size
 Impeller-index
 Motor power x 10
 Depth of immersion in mm

Max. Spanfracht: 5 g/l
 Max. Korngröße: 30 mm
 Laufrad-Werkstoff: GJL-250 (GG 25)
 Kennlinien für $\nu = 1 \text{ mm}^2/\text{s}$

Max. Spanfracht 5 g/l
 Max. grain size: 30 mm
 Impeller material: GJL-250 (GG 25)
 Characteristic lines for $\nu = 1 \text{ mm}^2/\text{s}$

TS 40

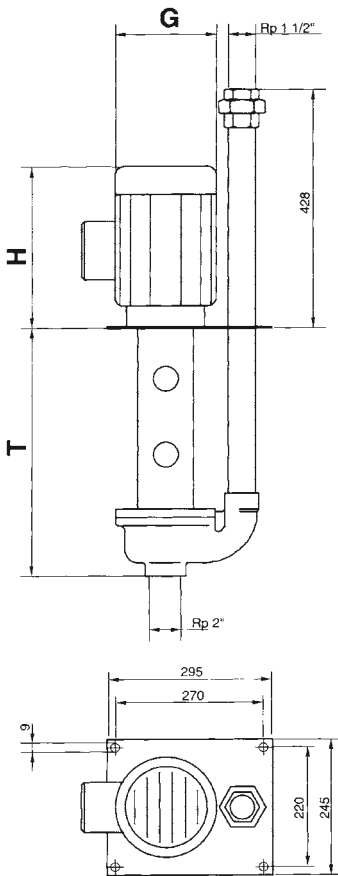

Nenn Drehzahl /
Nominal rotation speed 2900 min⁻¹ @ 50 Hz

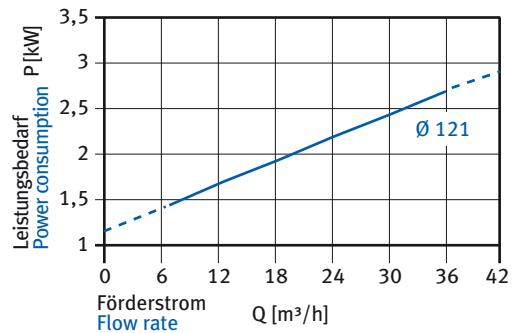
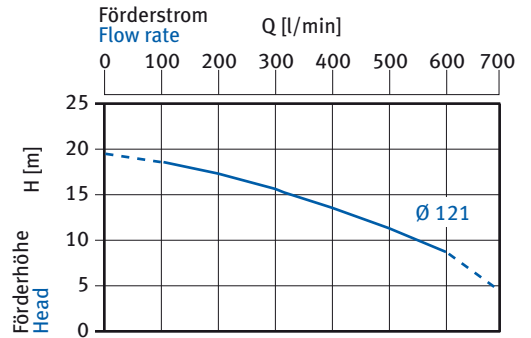

Nenn Drehzahl /
Nominal rotation speed 3500 min⁻¹ @ 60 Hz

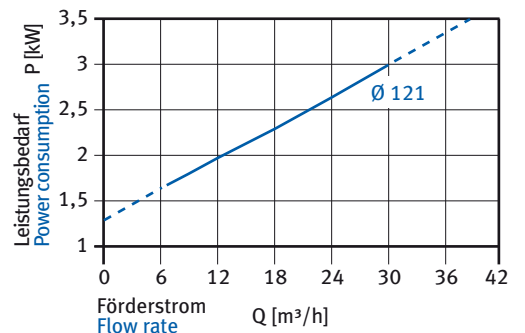
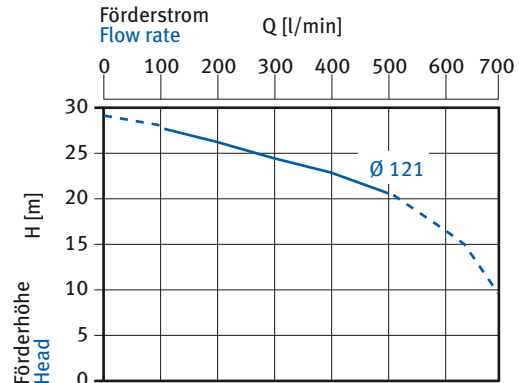

Typ/Type	T (mm)	H (mm)	G (mm)	Gewicht Weight (kg)	Motorleistung Motor power (kW)
TS 40-21/22 338	338	320	180	33	2,2
TS 40-21/30 338	338	350	200	37	3
TS 40-21/22 586	586	320	180	40	2,2
TS 40-21/30 586	586	350	200	44	3
TS 40-21/22 834	834	320	180	47	2,2
TS 40-21/30 834	834	350	200	51	3

Beispiel: Laufrad-Ø = 121 → TS 40-21/30 338

Example: Impeller-Ø = 121 → TS 40-21/30 338

Max. Spanfracht: 2 g/l
 Max. Korngröße: 12 mm
 Laufrad-Werkstoff: ST
 Kennlinien für $v = 1 \text{ mm}^2/\text{s}$

Max. grain load: 2 g/l
 Max. grain size: 12 mm
 Impeller material: ST
 Characteristic lines for $v = 1 \text{ mm}^2/\text{s}$

Tauchpumpe — TS 40-21/30 338
 Laufradform —
 Baugröße —
 Laufrad-Index —
 Motorleistung x 10 —
 Eintauchtiefe in mm —

Submerged pump — TS 40-21/30 338
 Form of impeller —
 Pump size —
 Impeller-index —
 Motor power x 10 —
 Depth of immersion in mm —

TSK 40

Nennzahl /
Nominal rotation speed
2900 min⁻¹ @ 50 Hz

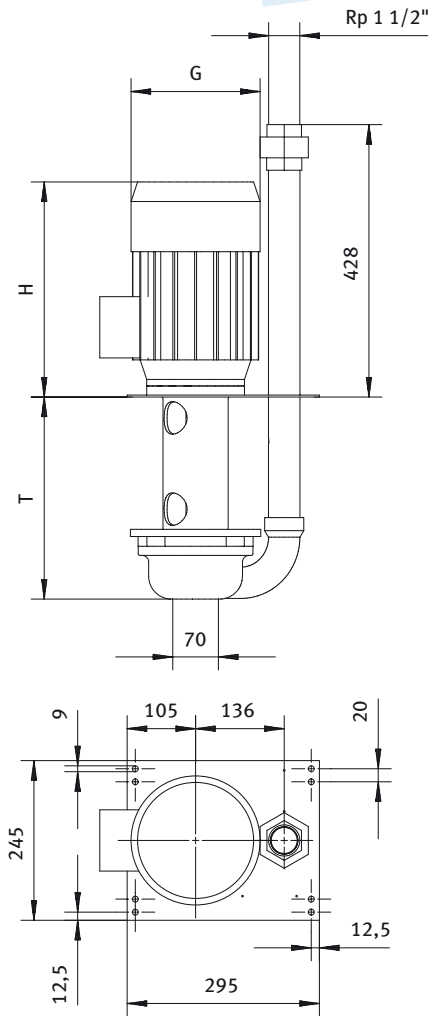
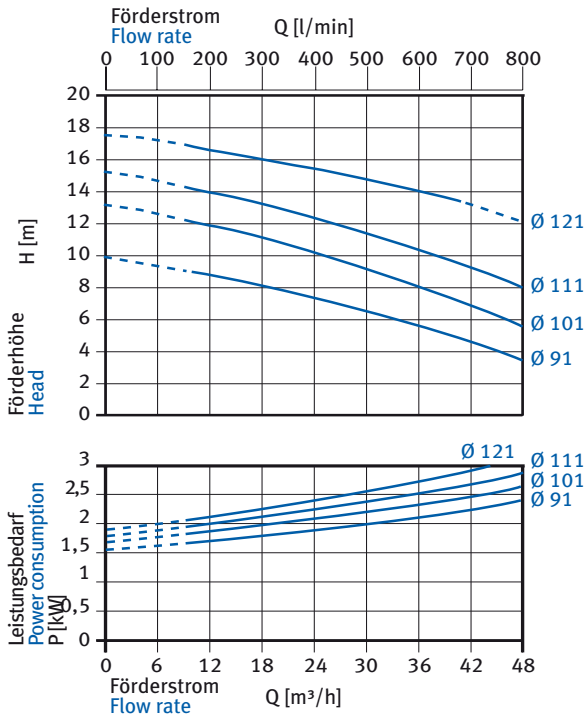

Nennzahl /
Nominal rotation speed
3500 min⁻¹ @ 60 Hz

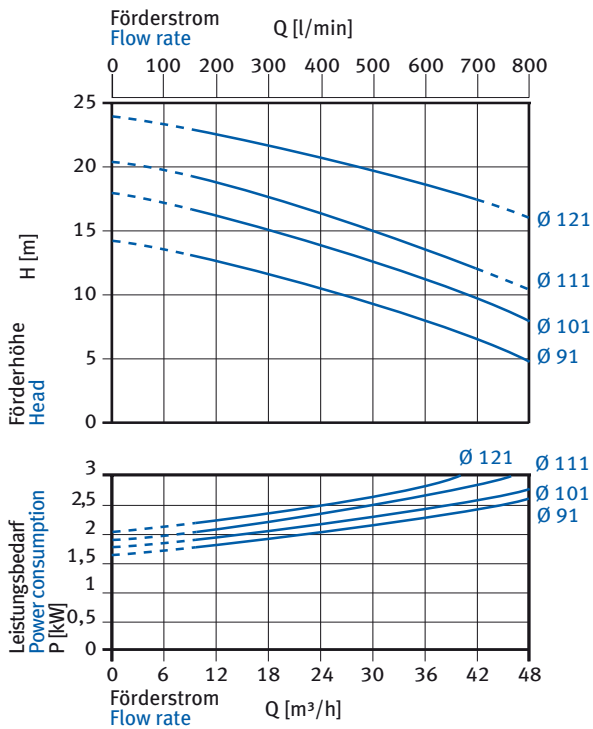

Typ/Type	T (mm)	H (mm)	G (mm)	Gewicht Weight (kg)	Motorleistung Motor power (kW)
TSK 40-../22 310	310	320	180	33	2,2
TSK 40-../30 310	310	350	200	37	3
TSK 40-../22 558	558	320	180	40	2,2
TSK 40-../30 558	558	350	200	44	3
TSK 40-../22 806	806	320	180	47	2,2
TSK 40-../30 806	806	350	200	51	3

Tauchpumpe — TSK 40-01/30 310
 Laufradform —
 Baugröße —
 Laufrad-Index —
 Motorleistung x 10 —
 Eintauchtiefe in mm —

Submerged pump — TSK 40-01/30 310
 Form of impeller —
 Pump size —
 Impeller-index —
 Motor power x 10 —
 Depth of immersion in mm —

Max. Spanfracht: 5 g/l
 Max. Korngröße: 20 mm
 Laufrad-Werkstoff: ST
 Kennlinien für $\nu = 1 \text{ mm}^2/\text{s}$

Max. grain load: 5 g/l
 Max. grain size: 20 mm
 Impeller material: ST
 Characteristic lines for $\nu = 1 \text{ mm}^2/\text{s}$

TSK 65

Nenn Drehzahl / Nominal rotation speed
2900 min⁻¹ @ 50 Hz

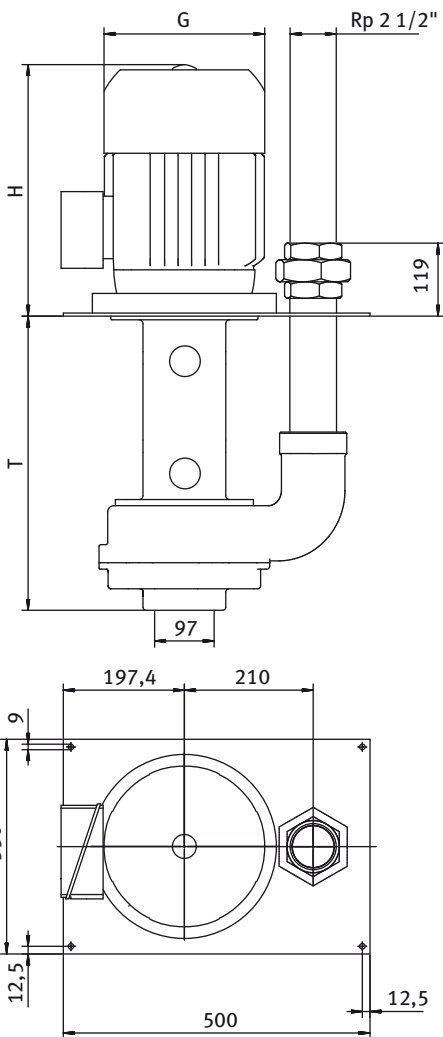

Förderstrom
Flow rate Q [l/min]

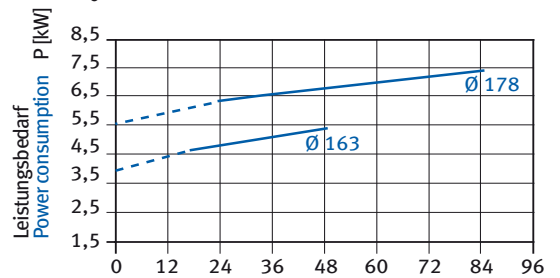
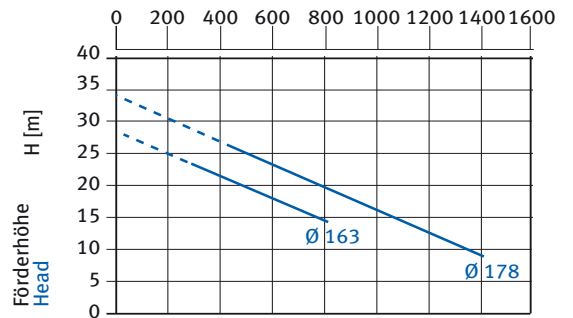

Förderstrom
Flow rate Q [m³/h]

Nenn Drehzahl / Nominal rotation speed
3500 min⁻¹ @ 60 Hz

Förderstrom
Flow rate Q [l/min]

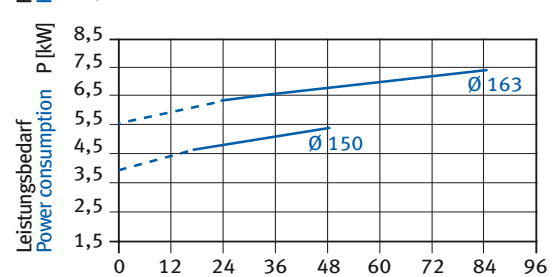
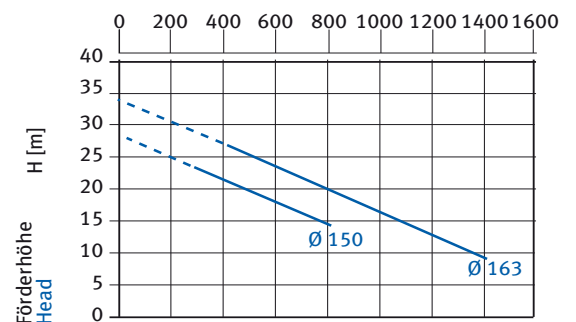

Förderstrom
Flow rate Q [m³/h]

Typ/Type	T (mm)	H (mm)	G (mm)	Gewicht Weight (kg)	Motorleistung Motor power (kW)
TSK 65-.../55 482	482	410	262	110	5,5
TSK 65-.../75 482	482	450	262	120	7,5
TSK 65-.../55 842	842	410	262	140	5,5
TSK 65-.../75 842	842	450	262	150	7,5

Max. Spanfracht: 10 g/l
Max. Korngröße: 20 mm
Lauf rad-Werkstoff: ST
Kennlinien für $\nu = 1 \text{ mm}^2/\text{s}$

Max. grain load: 10 g/l
Max. grain size: 20 mm
Impeller material: ST
Characteristic lines for $\nu = 1 \text{ mm}^2/\text{s}$

Tauchpumpe — TSK 65-63/55 482
Lauf radform — Submerged pump — TSK 65-63/55 482
Baugröße — Form of impeller
Lauf rad-Index — Pump size
Motorleistung x 10 — Impeller-index
Eintauchtiefe in mm — Motor power x 10
Depth of immersion in mm

T-Auslegungs-Checkliste

T design checklist

Firma **Company** _____

Adresse **Address** _____

Ansprechpartner **Contact** _____

Telefon **Telephone** _____

Telefax **Fax** _____

eMail _____

Bearbeitung Application	Werkstoff Materials	Schleifmittel Abrasive
<input type="checkbox"/> Drehen Turning	<input type="checkbox"/> Stahl Steel	<input type="checkbox"/> Korund Corundum
<input type="checkbox"/> Bohren Drilling	<input type="checkbox"/> Guss Cast	<input type="checkbox"/> CBN CBN
<input type="checkbox"/> Fräsen Milling	<input type="checkbox"/> Aluminium Aluminum	
<input type="checkbox"/> Schleifen Grinding	<input type="checkbox"/> Buntmetall Non ferrous metal	<input type="checkbox"/> Andere Other
	<input type="checkbox"/> Andere Other _____	

Niederdruckpumpe **Low pressure pump**

Förderstrom **Flow rate** _____ [l/min]

Förderdruck **Flow pressure** _____ [bar]

Fördermedium Piping medium	Filtration Filtration
<input type="checkbox"/> Emulsion Coolants	KNOLL-Anlage KNOLL-plant <input type="checkbox"/> ja yes <input type="checkbox"/> nein no
<input type="checkbox"/> Öl Oil	KNOLL-Auftrags-Nr. Order number _____
<input type="checkbox"/> Synth. Lösung Synth. medium	Filterart Filter _____
	Filterfeinheit Grade of filtration _____ [µm]
Viskosität Viscosity _____ [mm ² /s]	Restschmutzgehalt Dirt content _____ [mg/l]
Bearbeitungstemperatur Working temperature _____ [°C]	Korngröße Grain size _____ [mm]
	Spanfracht GrainLoad _____ [g/l]

Stromnetz **Electricity mains**

3 x 400 V, 50 Hz Andere **Other** _____

Aufstellungsart **Version**

- Tauchversion **Submerged version**
- Fußversion normal saugend **Foot mounted version normal priming**
- Fußversion selbstansaugend **Foot mounted version selfpriming**

KNOLL
.It works

KNOLL Maschinenbau GmbH
Schwarzachstraße 20
DE-88348 Bad Saulgau
Tel. + 49 (0) 75 81/20 08-0
Fax + 49 (0) 75 81/20 08-140
info.itworks@knoll-mb.de
www.knoll-mb.de

