



5.1 Overview

Low-backlash high-performance precision planetary geared motors

PHA

Technical data

i	4 – 100
M_{2acc}	24 – 7500 Nm
$\Delta\varphi_2$	1 – 2 arcmin
η	$\leq 93 - 96 \%$

Features

Power density	★★★★☆
Backlash	★★★★★
Price category	€€€€
Shaft load	★★★★★
Smooth operation	★★★★★
Torsional stiffness	★★★★☆
Mass moment of inertia	★★★★★
Helical gearing	✓
Maintenance-free	✓
Any installation position	✓
Continuous operation without cooling (FKM seal ring at the input and output)	✓
Pretensioned angular contact bearings at the output in an O-arrangement, ideally suited for helical-gear rack and pinion drives	✓
Compact and highly dynamic due to direct motor attachment	✓

Key: ★☆☆☆☆ good | ★★★★★ excellent

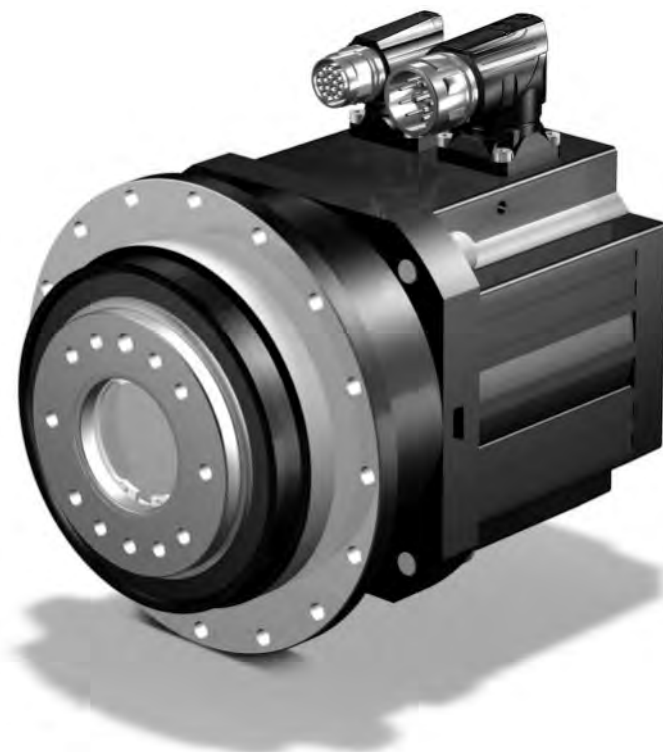



5.2 Selection tables

The technical data specified in the selection tables applies to:

- Installation altitudes up to 1000 m above sea level
- Surrounding temperatures from 0 °C to 40 °C
- Drives with convection-cooled motors (e.g. EZ401U)

You can calculate the technical data for drives with forced ventilated motors (for example EZ401B) at <http://products.stoeber.de>.

Formula symbol	Unit	Explanation
a_{th}	–	Parameter for calculating $K_{mot,th}$
C_2	Nm/ arcmin	Torsional stiffness of gear unit (final stiffness) relative to the gear unit output
$\Delta\varphi_2$	arcmin	Backlash at the output shaft with a blocked input
η	%	Efficiency
i	–	Gear ratio
i_{exakt}	–	Mathematically exact gear ratio
J_1	10^{-4}kgm^2	Mass moment of inertia relative to the gear unit input
m	kg	Weight
$M_{2,0}$	Nm	Stall torque on the gear unit output
M_{2acc}	Nm	Maximum permitted acceleration torque on the gear unit output
$M_{2acc,max}$	Nm	Maximum permitted acceleration torque of a group of geared motors whose size and nominal torque n_{1N} are the same
M_{2N}	Nm	Nominal torque on the gear unit output (relative to n_{1N})
M_{2NOT}	Nm	Gear unit emergency-off torque on the gear unit output for max. 1000 load changes
n_{1maxDB}	min^{-1}	Maximum permitted input speed of the gear unit in continuous operation (at surrounding temperature of 20 °C)
n_{1maxZB}	min^{-1}	Maximum permitted input speed of the gear unit in cyclic operation (at surrounding temperature of 20 °C)
n_{1N}	min^{-1}	Nominal speed at the gear unit input
n_{2N}	min^{-1}	Nominal speed at the gear unit output
S	–	Load value: Quotient of gear unit and motor nominal torque without regard to the thermal performance limit. Represents a value for the reserve of the geared motor.



5 PHA planetary geared motors

5.2 Selection tables



n_{2N}	M_{2N}	$M_{2,0}$	a_{th}	S	Type	M_{2acc}	M_{2NOT}	i	i_{exakt}	n_{1max} DB	n_{1max} ZB	J_1	$\Delta\varphi_2$	C_2	m
[rpm]	[Nm]	[Nm]				[Nm]	[Nm]			[rpm]	[rpm]	[10 ⁻⁴ kgm ²]	[arcmin]	[Nm/ arcmin]	[kg]
PHA3 ($n_{1N} = 3000 \text{ rpm}$, $M_{2acc,max} = 65 \text{ Nm}$)															
60	43	44	1.5	1.0	PHA322F0500 EZ301U	65	130	50.00	50/1	4500	8000	0.20	2	14	2.9
86	30	31	1.8	1.5	PHA322F0350 EZ301U	65	130	35.00	35/1	4500	8000	0.20	2	15	2.9
107	24	25	2.0	1.9	PHA322F0280 EZ301U	60	130	28.00	28/1	4500	8000	0.23	2	15	2.9
107	41	44	3.5	1.1	PHA322F0280 EZ302U	60	130	28.00	28/1	4500	8000	0.33	2	15	3.5
120	22	22	2.2	2.1	PHA322F0250 EZ301U	65	130	25.00	25/1	4500	8000	0.22	2	15	2.9
120	37	39	3.7	1.2	PHA322F0250 EZ302U	65	130	25.00	25/1	4500	8000	0.32	2	15	3.5
150	17	18	2.4	2.6	PHA322F0200 EZ301U	52	130	20.00	20/1	4500	8000	0.24	2	15	2.9
150	30	31	4.1	1.5	PHA322F0200 EZ302U	65	130	20.00	20/1	4500	8000	0.34	2	15	3.5
150	39	41	5.4	1.2	PHA322F0200 EZ303U	65	130	20.00	20/1	4500	8000	0.45	2	15	4.0
300	8.9	9.1	1.6	2.9	PHA321F0100 EZ301U	27	100	10.00	10/1	3800	6000	0.21	2	11	2.4
300	15	16	2.8	1.7	PHA321F0100 EZ302U	48	100	10.00	10/1	3800	6000	0.31	2	11	3.0
300	20	21	3.6	1.3	PHA321F0100 EZ303U	50	100	10.00	10/1	3800	6000	0.42	2	11	3.5
429	11	11	2.9	3.7	PHA321F0070 EZ302U	34	130	7.000	7/1	3500	6000	0.33	2	14	3.0
429	14	15	3.7	2.8	PHA321F0070 EZ303U	47	130	7.000	7/1	3500	6000	0.44	2	14	3.5
429	19	20	5.0	2.1	PHA321F0070 EZ401U	57	130	7.000	7/1	3500	6000	0.97	2	14	4.9
429	32	35	8.4	1.2	PHA321F0070 EZ402U	60	130	7.000	7/1	3500	6000	1.7	2	14	6.0
600	9.9	11	5.6	4.0	PHA321F0050 EZ303U	34	110	5.000	5/1	3000	6000	0.47	2	16	3.5
600	13	14	7.5	2.9	PHA321F0050 EZ401U	41	130	5.000	5/1	3000	6000	1.0	2	16	4.9
600	23	25	13	1.7	PHA321F0050 EZ402U	65	130	5.000	5/1	3000	6000	1.7	2	16	6.0
600	33	41	19	1.2	PHA321F0050 EZ404U	65	130	5.000	5/1	3000	6000	3.1	2	16	8.1
PHA3 ($n_{1N} = 6000 \text{ rpm}$, $M_{2acc,max} = 65 \text{ Nm}$)															
171	29	31	1.7	1.6	PHA322F0350 EZ301U	65	130	35.00	35/1	4500	8000	0.20	2	15	2.9
214	23	25	1.9	1.9	PHA322F0280 EZ301U	60	130	28.00	28/1	4500	8000	0.23	2	15	2.9
214	39	44	3.3	1.2	PHA322F0280 EZ302U	60	130	28.00	28/1	4500	8000	0.33	2	15	3.5
240	21	22	2.1	2.2	PHA322F0250 EZ301U	65	130	25.00	25/1	4500	8000	0.22	2	15	2.9
240	35	39	3.5	1.3	PHA322F0250 EZ302U	65	130	25.00	25/1	4500	8000	0.32	2	15	3.5
300	17	18	2.3	2.7	PHA322F0200 EZ301U	52	130	20.00	20/1	4500	8000	0.24	2	15	2.9
300	28	31	3.9	1.6	PHA322F0200 EZ302U	65	130	20.00	20/1	4500	8000	0.34	2	15	3.5
300	36	42	5.1	1.2	PHA322F0200 EZ303U	65	130	20.00	20/1	4500	8000	0.45	2	15	4.0
600	8.5	9.1	2.0	2.4	PHA321F0100 EZ301U	27	100	10.00	10/1	3800	6000	0.21	2	11	2.4
600	14	16	3.3	1.4	PHA321F0100 EZ302U	48	100	10.00	10/1	3800	6000	0.31	2	11	3.0
600	19	22	4.3	1.1	PHA321F0100 EZ303U	50	100	10.00	10/1	3800	6000	0.42	2	11	3.5
857	10	11	3.4	3.1	PHA321F0070 EZ302U	34	130	7.000	7/1	3500	6000	0.33	2	14	3.0
857	13	15	4.4	2.4	PHA321F0070 EZ303U	47	130	7.000	7/1	3500	6000	0.44	2	14	3.5
857	15	19	5.2	2.0	PHA321F0070 EZ401U	57	130	7.000	7/1	3500	6000	0.97	2	14	4.9
857	24	33	7.9	1.3	PHA321F0070 EZ402U	60	130	7.000	7/1	3500	6000	1.7	2	14	6.0
1200	7.2	8.1	5.1	4.3	PHA321F0050 EZ302U	24	110	5.000	5/1	3000	6000	0.36	2	16	3.0
1200	9.4	11	6.6	3.3	PHA321F0050 EZ303U	34	110	5.000	5/1	3000	6000	0.47	2	16	3.5
1200	11	13	7.8	2.8	PHA321F0050 EZ401U	41	130	5.000	5/1	3000	6000	1.0	2	16	4.9
1200	17	24	12	1.9	PHA321F0050 EZ402U	65	130	5.000	5/1	3000	6000	1.7	2	16	6.0
1200	28	40	20	1.1	PHA321F0050 EZ404U	65	130	5.000	5/1	3000	6000	3.1	2	16	8.1
PHA4 ($n_{1N} = 3000 \text{ rpm}$, $M_{2acc,max} = 130 \text{ Nm}$)															
43	61	62	0.7	1.5	PHA422F0700 EZ301U	110	240	70.00	70/1	4500	8000	0.21	1	27	5.3
60	43	44	0.9	2.1	PHA422F0500 EZ301U	130	240	50.00	50/1	4500	8000	0.21	1	27	5.3
60	74	78	1.5	1.2	PHA422F0500 EZ302U	130	240	50.00	50/1	4500	8000	0.31	1	27	5.9
75	35	35	1.0	2.6	PHA422F0400 EZ301U	100	240	40.00	40/1	4500	8000	0.21	1	24	5.3
75	59	62	1.6	1.5	PHA422F0400 EZ302U	130	240	40.00	40/1	4500	8000	0.31	1	24	5.9
75	77	81	2.1	1.2	PHA422F0400 EZ303U	130	240	40.00	40/1	4500	8000	0.42	1	24	6.4
86	30	31	1.0	3.0	PHA422F0350 EZ301U	91	240	35.00	35/1	4500	8000	0.23	1	28	5.3
86	52	55	1.8	1.7	PHA422F0350 EZ302U	130	240	35.00	35/1	4500	8000	0.33	1	28	5.9
86	67	71	2.3	1.3	PHA422F0350 EZ303U	130	240	35.00	35/1	4500	8000	0.44	1	28	6.4
107	24	25	1.1	3.7	PHA422F0280 EZ301U	73	240	28.00	28/1	4500	8000	0.24	1	25	5.3
107	41	44	2.0	2.2	PHA422F0280 EZ302U	130	240	28.00	28/1	4500	8000	0.34	1	25	5.9
107	54	57	2.5	1.7	PHA422F0280 EZ303U	130	240	28.00	28/1	4500	8000	0.45	1	25	6.4
107	73	78	3.4	1.2	PHA422F0280 EZ401U	130	240	28.00	28/1	4500	8000	0.98	1	25	7.8
120	22	22	1.2	4.2	PHA422F0250 EZ301U	65	240	25.00	25/1	4000	7000	0.28	1	29	5.3
120	37	39	2.1	2.4	PHA422F0250 EZ302U	120	240	25.00	25/1	4000	7000	0.38	1	29	5.9
120	48	51	2.7	1.9	PHA422F0250 EZ303U	130	240	25.00	25/1	4000	7000	0.49	1	29	6.4
120	65	70	3.6	1.4	PHA422F0250 EZ401U	130	240	25.00	25/1	4000	7000	1.0	1	29	7.8

PHA

5 PHA planetary geared motors

5.2 Selection tables



n_{2N}	M_{2N}	$M_{2,0}$	a_{in}	S	Type	M_{zacc}	M_{2NOT}	i	i_{exakt}	n_{1max} DB	n_{1max} ZB	J_1	$\Delta\phi_2$	C_2	m
[rpm]	[Nm]	[Nm]				[Nm]	[Nm]			[rpm]	[rpm]	[10 ⁻⁴ kgm ²]	[arcmin]	[Nm/ arcmin]	[kg]
PHA4 ($n_{1N} = 3000$ rpm, $M_{zacc,max} = 130$ Nm)															
150	30	31	2.3	3.0	PHA422F0200 EZ302U	93	240	20.00	20/1	3700	6500	0.43	1	29	5.9
150	39	41	3.0	2.3	PHA422F0200 EZ303U	130	240	20.00	20/1	3700	6500	0.54	1	29	6.4
150	52	56	4.1	1.7	PHA422F0200 EZ401U	130	240	20.00	20/1	3700	6500	1.1	1	29	7.8
150	80	87	6.3	1.1	PHA422F0200 EZ501U	130	240	20.00	20/1	3700	6500	3.0	1	29	8.8
150	87	97	6.8	1.0	PHA422F0200 EZ402U	130	240	20.00	20/1	3700	6500	1.8	1	29	8.9
188	24	25	2.6	3.8	PHA422F0160 EZ302U	74	240	16.00	16/1	3700	6500	0.44	1	27	5.9
188	31	33	3.4	2.9	PHA422F0160 EZ303U	100	240	16.00	16/1	3700	6500	0.55	1	27	6.4
188	42	45	4.6	2.2	PHA422F0160 EZ401U	130	240	16.00	16/1	3700	6500	1.1	1	27	7.8
188	64	70	7.0	1.4	PHA422F0160 EZ501U	130	240	16.00	16/1	3700	6500	3.1	1	27	8.8
188	70	77	7.6	1.3	PHA422F0160 EZ402U	130	240	16.00	16/1	3700	6500	1.8	1	27	8.9
300	27	29	2.8	2.0	PHA421F0100 EZ401U	82	200	10.00	10/1	3500	6000	1.0	1	21	6.5
300	41	45	4.2	1.3	PHA421F0100 EZ501U	100	200	10.00	10/1	3500	6000	3.0	1	21	7.5
300	45	50	4.6	1.2	PHA421F0100 EZ402U	100	200	10.00	10/1	3500	6000	1.7	1	21	7.6
429	19	20	3.0	3.9	PHA421F0070 EZ401U	57	240	7.000	7/1	3200	6000	1.1	1	31	6.5
429	29	32	4.6	2.6	PHA421F0070 EZ501U	110	240	7.000	7/1	3200	6000	3.1	1	31	7.5
429	32	35	5.0	2.4	PHA421F0070 EZ402U	110	240	7.000	7/1	3200	6000	1.8	1	31	7.6
429	46	58	7.4	1.6	PHA421F0070 EZ404U	110	240	7.000	7/1	3200	6000	3.1	1	31	9.7
429	50	54	7.9	1.5	PHA421F0070 EZ502U	110	240	7.000	7/1	3200	6000	5.4	1	31	9.0
429	65	75	10	1.1	PHA421F0070 EZ503U	110	240	7.000	7/1	3200	6000	7.7	1	31	11
600	21	23	6.9	3.6	PHA421F0050 EZ501U	77	240	5.000	5/1	2700	6000	3.2	1	37	7.5
600	23	25	7.5	3.3	PHA421F0050 EZ402U	77	240	5.000	5/1	2700	6000	1.9	1	37	7.6
600	33	41	11	2.2	PHA421F0050 EZ404U	130	240	5.000	5/1	2700	6000	3.3	1	37	9.7
600	36	38	12	2.1	PHA421F0050 EZ502U	130	240	5.000	5/1	2700	6000	5.5	1	37	9.0
600	47	53	16	1.6	PHA421F0050 EZ503U	130	240	5.000	5/1	2700	6000	7.9	1	37	11
600	65	77	22	1.1	PHA421F0050 EZ505U	130	240	5.000	5/1	2700	6000	12	1	37	13
750	17	18	9.0	4.5	PHA421F0040 EZ501U	61	240	4.000	4/1	2300	5000	3.4	1	39	7.5
750	18	20	9.8	4.1	PHA421F0040 EZ402U	61	200	4.000	4/1	2300	5000	2.1	1	39	7.6
750	26	33	14	2.8	PHA421F0040 EZ404U	110	240	4.000	4/1	2300	5000	3.5	1	39	9.7
750	28	31	15	2.6	PHA421F0040 EZ502U	120	240	4.000	4/1	2300	5000	5.7	1	39	9.0
750	37	43	20	2.0	PHA421F0040 EZ503U	130	240	4.000	4/1	2300	5000	8.1	1	39	11
750	52	61	28	1.4	PHA421F0040 EZ505U	130	240	4.000	4/1	2300	5000	13	1	39	13
PHA4 ($n_{1N} = 4500$ rpm, $M_{zacc,max} = 130$ Nm)															
900	46	73	17	1.4	PHA421F0050 EZ505U	130	240	5.000	5/1	2700	6000	12	1	37	13
1125	36	59	23	1.8	PHA421F0040 EZ505U	130	240	4.000	4/1	2300	5000	13	1	39	13
PHA4 ($n_{1N} = 6000$ rpm, $M_{zacc,max} = 130$ Nm)															
86	58	62	0.7	1.6	PHA422F0700 EZ301U	110	240	70.00	70/1	4500	8000	0.21	1	27	5.3
120	41	44	0.8	2.2	PHA422F0500 EZ301U	130	240	50.00	50/1	4500	8000	0.21	1	27	5.3
120	70	78	1.4	1.3	PHA422F0500 EZ302U	130	240	50.00	50/1	4500	8000	0.31	1	27	5.9
150	33	35	1.0	2.4	PHA422F0400 EZ301U	100	240	40.00	40/1	4500	8000	0.21	1	24	5.3
150	56	62	1.7	1.4	PHA422F0400 EZ302U	130	240	40.00	40/1	4500	8000	0.31	1	24	5.9
150	73	84	2.3	1.1	PHA422F0400 EZ303U	130	240	40.00	40/1	4500	8000	0.42	1	24	6.4
171	29	31	1.0	3.1	PHA422F0350 EZ301U	91	240	35.00	35/1	4500	8000	0.23	1	28	5.3
171	49	55	1.7	1.8	PHA422F0350 EZ302U	130	240	35.00	35/1	4500	8000	0.33	1	28	5.9
171	64	73	2.2	1.4	PHA422F0350 EZ303U	130	240	35.00	35/1	4500	8000	0.44	1	28	6.4
171	75	91	2.5	1.2	PHA422F0350 EZ401U	130	240	35.00	35/1	4500	8000	0.97	1	28	7.8
214	23	25	1.1	3.9	PHA422F0280 EZ301U	73	240	28.00	28/1	4500	8000	0.24	1	25	5.3
214	39	44	1.8	2.3	PHA422F0280 EZ302U	130	240	28.00	28/1	4500	8000	0.34	1	25	5.9
214	51	59	2.4	1.8	PHA422F0280 EZ303U	130	240	28.00	28/1	4500	8000	0.45	1	25	6.4
214	60	73	2.8	1.5	PHA422F0280 EZ401U	130	240	28.00	28/1	4500	8000	0.98	1	25	7.8
240	21	22	1.2	4.3	PHA422F0250 EZ301U	65	240	25.00	25/1	4000	7000	0.28	1	29	5.3
240	35	39	2.0	2.6	PHA422F0250 EZ302U	120	240	25.00	25/1	4000	7000	0.38	1	29	5.9
240	46	52	2.6	2.0	PHA422F0250 EZ303U	130	240	25.00	25/1	4000	7000	0.49	1	29	6.4
240	53	65	3.0	1.7	PHA422F0250 EZ401U	130	240	25.00	25/1	4000	7000	1.0	1	29	7.8
300	28	31	2.2	3.2	PHA422F0200 EZ302U	93	240	20.00	20/1	3700	6500	0.43	1	29	5.9
300	36	42	2.9	2.5	PHA422F0200 EZ303U	130	240	20.00	20/1	3700	6500	0.54	1	29	6.4
300	43	52	3.3	2.1	PHA422F0200 EZ401U	130	240	20.00	20/1	3700	6500	1.1	1	29	7.8
300	63	82	5.0	1.4	PHA422F0200 EZ501U	130	240	20.00	20/1	3700	6500	3.0	1	29	8.8
300	65	91	5.1	1.4	PHA422F0200 EZ402U	130	240	20.00	20/1	3700	6500	1.8	1	29	8.9
375	22	25	2.4	4.0	PHA422F0160 EZ302U	74	240	16.00	16/1	3700	6500	0.44	1	27	5.9



5 PHA planetary geared motors
5.2 Selection tables

STÖBER

n_{2N}	M_{2N}	$M_{2,0}$	a_{th}	S	Type	M_{2acc}	M_{2NOT}	i	i_{exakt}	n_{1max} DB	n_{1max} ZB	J_1	$\Delta\varphi_2$	C_2	m
[rpm]	[Nm]	[Nm]				[Nm]	[Nm]			[rpm]	[rpm]	[10 ⁻⁴ kgm ²]	[arcmin]	[Nm/ arcmin]	[kg]
PHA4 ($n_{1N} = 6000$ rpm, $M_{2acc,max} = 130$ Nm)															
375	29	33	3.2	3.1	PHA422F0160 EZ303U	100	240	16.00	16/1	3700	6500	0.55	1	27	6.4
375	34	42	3.7	2.6	PHA422F0160 EZ401U	130	240	16.00	16/1	3700	6500	1.1	1	27	7.8
375	51	65	5.5	1.8	PHA422F0160 EZ501U	130	240	16.00	16/1	3700	6500	3.1	1	27	8.8
375	52	73	5.7	1.7	PHA422F0160 EZ402U	130	240	16.00	16/1	3700	6500	1.8	1	27	8.9
600	22	27	2.9	1.9	PHA421F0100 EZ401U	82	200	10.00	10/1	3500	6000	1.0	1	21	6.5
600	33	42	4.2	1.3	PHA421F0100 EZ501U	100	200	10.00	10/1	3500	6000	3.0	1	21	7.5
600	34	47	4.4	1.2	PHA421F0100 EZ402U	100	200	10.00	10/1	3500	6000	1.7	1	21	7.6
857	15	19	3.1	3.8	PHA421F0070 EZ401U	57	240	7.000	7/1	3200	6000	1.1	1	31	6.5
857	23	30	4.6	2.6	PHA421F0070 EZ501U	110	240	7.000	7/1	3200	6000	3.1	1	31	7.5
857	24	33	4.7	2.5	PHA421F0070 EZ402U	110	240	7.000	7/1	3200	6000	1.8	1	31	7.6
857	35	52	7.0	1.7	PHA421F0070 EZ502U	110	240	7.000	7/1	3200	6000	5.4	1	31	9.0
857	39	56	7.8	1.5	PHA421F0070 EZ404U	110	240	7.000	7/1	3200	6000	3.1	1	31	9.7
857	42	71	8.4	1.4	PHA421F0070 EZ503U	110	240	7.000	7/1	3200	6000	7.7	1	31	11
1200	16	21	6.9	3.6	PHA421F0050 EZ501U	77	240	5.000	5/1	2700	6000	3.2	1	37	7.5
1200	17	24	7.1	3.5	PHA421F0050 EZ402U	77	240	5.000	5/1	2700	6000	1.9	1	37	7.6
1200	25	37	10	2.4	PHA421F0050 EZ502U	130	240	5.000	5/1	2700	6000	5.5	1	37	9.0
1200	28	40	12	2.1	PHA421F0050 EZ404U	130	240	5.000	5/1	2700	6000	3.3	1	37	9.7
1200	30	51	13	2.0	PHA421F0050 EZ503U	130	240	5.000	5/1	2700	6000	7.9	1	37	11
PHA5 ($n_{1N} = 3000$ rpm, $M_{2acc,max} = 320$ Nm)															
43	182	195	1.0	1.2	PHA522F0700 EZ401U	270	600	70.00	70/1	4000	7000	0.98	1	66	11
60	130	140	1.2	1.7	PHA522F0500 EZ401U	320	600	50.00	50/1	4000	7000	0.98	1	66	11
60	200	219	1.8	1.1	PHA522F0500 EZ501U	320	600	50.00	50/1	4000	7000	3.0	1	66	12
60	219	242	2.0	1.0	PHA522F0500 EZ402U	320	600	50.00	50/1	4000	7000	1.7	1	66	12
75	104	112	1.4	1.9	PHA522F0400 EZ401U	320	600	40.00	40/1	4000	7000	0.98	1	58	11
75	160	175	2.2	1.3	PHA522F0400 EZ501U	320	600	40.00	40/1	4000	7000	2.9	1	58	12
75	175	193	2.4	1.2	PHA522F0400 EZ402U	320	600	40.00	40/1	4000	7000	1.7	1	58	12
86	91	98	1.4	2.4	PHA522F0350 EZ401U	280	600	35.00	35/1	4000	7000	1.0	1	68	11
86	140	153	2.2	1.6	PHA522F0350 EZ501U	320	600	35.00	35/1	4000	7000	3.0	1	68	12
86	153	169	2.4	1.4	PHA522F0350 EZ402U	320	600	35.00	35/1	4000	7000	1.7	1	68	12
107	73	78	1.6	2.9	PHA522F0280 EZ401U	220	600	28.00	28/1	4000	7000	1.0	1	61	11
107	112	122	2.5	1.9	PHA522F0280 EZ501U	320	600	28.00	28/1	4000	7000	3.0	1	61	12
107	122	135	2.8	1.7	PHA522F0280 EZ402U	320	600	28.00	28/1	4000	7000	1.7	1	61	12
107	180	224	4.0	1.2	PHA522F0280 EZ404U	320	600	28.00	28/1	4000	7000	3.1	1	61	14
107	193	208	4.3	1.1	PHA522F0280 EZ502U	320	600	28.00	28/1	4000	7000	5.3	1	61	13
120	65	70	1.7	3.4	PHA522F0250 EZ401U	200	600	25.00	25/1	3700	6500	1.2	1	71	11
120	100	109	2.5	2.2	PHA522F0250 EZ501U	320	600	25.00	25/1	3700	6500	3.1	1	71	12
120	109	121	2.8	2.0	PHA522F0250 EZ402U	320	600	25.00	25/1	3700	6500	1.9	1	71	12
120	160	200	4.1	1.4	PHA522F0250 EZ404U	320	600	25.00	25/1	3700	6500	3.2	1	71	14
120	172	186	4.4	1.3	PHA522F0250 EZ502U	320	600	25.00	25/1	3700	6500	5.4	1	71	13
120	172	193	4.4	1.3	PHA522F0250 EZ701U	320	600	25.00	25/1	3700	6500	8.7	1	71	15
150	52	56	1.9	4.2	PHA522F0200 EZ401U	160	600	20.00	20/1	3300	6000	1.3	1	71	11
150	80	87	2.8	2.8	PHA522F0200 EZ501U	300	600	20.00	20/1	3300	6000	3.2	1	71	12
150	87	97	3.1	2.5	PHA522F0200 EZ402U	300	600	20.00	20/1	3300	6000	2.0	1	71	12
150	128	160	4.6	1.7	PHA522F0200 EZ404U	320	600	20.00	20/1	3300	6000	3.3	1	71	14
150	138	149	4.9	1.6	PHA522F0200 EZ502U	320	600	20.00	20/1	3300	6000	5.5	1	71	13
150	138	154	4.9	1.6	PHA522F0200 EZ701U	320	600	20.00	20/1	3300	6000	8.8	1	71	15
150	180	206	6.4	1.2	PHA522F0200 EZ503U	320	600	20.00	20/1	3300	6000	7.9	1	71	15
188	64	70	3.3	3.3	PHA522F0160 EZ501U	240	600	16.00	16/1	3300	6000	3.2	1	65	12
188	70	77	3.6	3.0	PHA522F0160 EZ402U	240	600	16.00	16/1	3300	6000	1.9	1	65	12
188	103	128	5.3	2.0	PHA522F0160 EZ404U	320	600	16.00	16/1	3300	6000	3.3	1	65	14
188	110	119	5.7	1.9	PHA522F0160 EZ502U	320	600	16.00	16/1	3300	6000	5.5	1	65	13
188	110	124	5.7	1.9	PHA522F0160 EZ701U	300	600	16.00	16/1	3300	6000	8.8	1	65	15
188	144	165	7.5	1.5	PHA522F0160 EZ503U	320	600	16.00	16/1	3300	6000	7.9	1	65	15
188	179	214	9.3	1.2	PHA522F0160 EZ702U	320	600	16.00	16/1	3300	6000	14	1	65	18
188	201	238	10	1.0	PHA522F0160 EZ505U	320	600	16.00	16/1	3300	6000	12	1	65	18
300	41	45	2.0	3.0	PHA521F0100 EZ501U	150	500	10.00	10/1	3300	6000	3.1	1	55	9.5
300	71	77	3.5	1.7	PHA521F0100 EZ502U	250	500	10.00	10/1	3300	6000	5.4	1	55	11
300	71	80	3.5	1.7	PHA521F0100 EZ701U	190	500	10.00	10/1	3300	6000	8.7	1	55	13
300	93	107	4.6	1.3	PHA521F0100 EZ503U	250	500	10.00	10/1	3300	6000	7.8	1	55	13

PHA



5 PHA planetary geared motors

5.2 Selection tables

n_{2N}	M_{2N}	$M_{2,0}$	a_{in}	S	Type	M_{2acc}	M_{2NOT}	i	i_{exakt}	n_{1max} DB	n_{1max} ZB	J_1	$\Delta\phi_2$	C_2	m
[rpm]	[Nm]	[Nm]				[Nm]	[Nm]			[rpm]	[rpm]	[10^{-4} kgm ²]	[arcmin]	[Nm/ arcmin]	[kg]
PHA5 ($n_{1N} = 3000$ rpm, $M_{2acc,max} = 320$ Nm)															
300	115	138	5.6	1.1	PHA521F0100 EZ702U	250	500	10.00	10/1	3300	6000	14	1	55	15
429	50	54	3.6	3.7	PHA521F0070 EZ502U	210	600	7.000	7/1	3000	6000	5.7	1	77	11
429	50	56	3.6	3.7	PHA521F0070 EZ701U	130	600	7.000	7/1	3000	6000	9.0	1	77	13
429	65	75	4.7	2.8	PHA521F0070 EZ503U	270	600	7.000	7/1	3000	6000	8.1	1	77	13
429	81	97	5.8	2.3	PHA521F0070 EZ702U	270	600	7.000	7/1	3000	6000	14	1	77	15
429	91	108	6.5	2.0	PHA521F0070 EZ505U	270	600	7.000	7/1	3000	6000	13	1	77	15
429	111	140	7.9	1.7	PHA521F0070 EZ703U	270	600	7.000	7/1	3000	6000	22	1	77	17
600	47	53	7.0	3.9	PHA521F0050 EZ503U	210	430	5.000	5/1	2500	5500	8.6	1	93	13
600	58	69	8.6	3.2	PHA521F0050 EZ702U	200	600	5.000	5/1	2500	5500	15	1	93	15
600	65	77	9.7	2.8	PHA521F0050 EZ505U	320	600	5.000	5/1	2500	5500	13	1	93	15
600	79	100	12	2.3	PHA521F0050 EZ703U	310	600	5.000	5/1	2500	5500	23	1	93	17
600	102	145	15	1.8	PHA521F0050 EZ705U	320	600	5.000	5/1	2500	5500	35	1	93	23
750	37	43	9.1	4.9	PHA521F0040 EZ503U	170	340	4.000	4/1	2200	5000	9.1	1	98	13
750	46	55	11	4.0	PHA521F0040 EZ702U	160	600	4.000	4/1	2200	5000	15	1	98	15
750	52	61	13	3.5	PHA521F0040 EZ505U	260	600	4.000	4/1	2200	5000	14	1	98	15
750	63	80	16	2.9	PHA521F0040 EZ703U	250	600	4.000	4/1	2200	5000	23	1	98	17
750	82	116	20	2.2	PHA521F0040 EZ705U	320	600	4.000	4/1	2200	5000	36	1	98	23
PHA5 ($n_{1N} = 4500$ rpm, $M_{2acc,max} = 320$ Nm)															
281	141	228	7.4	1.5	PHA522F0160 EZ505U	320	600	16.00	16/1	3300	6000	12	1	65	18
450	91	147	5.1	1.2	PHA521F0100 EZ505U	250	500	10.00	10/1	3300	6000	12	1	55	15
643	64	103	5.2	2.5	PHA521F0070 EZ505U	270	600	7.000	7/1	3000	6000	13	1	77	15
643	81	134	6.7	2.0	PHA521F0070 EZ703U	270	600	7.000	7/1	3000	6000	22	1	77	17
900	46	73	7.8	3.5	PHA521F0050 EZ505U	320	600	5.000	5/1	2500	5500	13	1	93	15
900	58	96	10	2.8	PHA521F0050 EZ703U	310	600	5.000	5/1	2500	5500	23	1	93	17
900	79	144	14	2.0	PHA521F0050 EZ705U	320	600	5.000	5/1	2500	5500	35	1	93	23
1125	36	59	10	4.4	PHA521F0040 EZ505U	260	600	4.000	4/1	2200	5000	14	1	98	15
1125	46	77	13	3.4	PHA521F0040 EZ703U	250	600	4.000	4/1	2200	5000	23	1	98	17
1125	63	115	18	2.5	PHA521F0040 EZ705U	320	600	4.000	4/1	2200	5000	36	1	98	23
PHA5 ($n_{1N} = 6000$ rpm, $M_{2acc,max} = 320$ Nm)															
86	150	182	0.9	1.4	PHA522F0700 EZ401U	270	600	70.00	70/1	4000	7000	0.98	1	66	11
120	107	130	1.1	1.9	PHA522F0500 EZ401U	320	600	50.00	50/1	4000	7000	0.98	1	66	11
120	158	205	1.6	1.3	PHA522F0500 EZ501U	320	600	50.00	50/1	4000	7000	3.0	1	66	12
120	163	228	1.6	1.2	PHA522F0500 EZ402U	320	600	50.00	50/1	4000	7000	1.7	1	66	12
150	86	104	1.5	1.9	PHA522F0400 EZ401U	320	600	40.00	40/1	4000	7000	0.98	1	58	11
150	126	164	2.2	1.3	PHA522F0400 EZ501U	320	600	40.00	40/1	4000	7000	2.9	1	58	12
150	130	182	2.3	1.2	PHA522F0400 EZ402U	320	600	40.00	40/1	4000	7000	1.7	1	58	12
171	75	91	1.2	2.9	PHA522F0350 EZ401U	280	600	35.00	35/1	4000	7000	1.0	1	68	11
171	111	143	1.7	2.0	PHA522F0350 EZ501U	320	600	35.00	35/1	4000	7000	3.0	1	68	12
171	114	159	1.8	1.9	PHA522F0350 EZ402U	320	600	35.00	35/1	4000	7000	1.7	1	68	12
214	60	73	1.3	3.5	PHA522F0280 EZ401U	220	600	28.00	28/1	4000	7000	1.0	1	61	11
214	89	115	2.0	2.4	PHA522F0280 EZ501U	320	600	28.00	28/1	4000	7000	3.0	1	61	12
214	91	128	2.1	2.3	PHA522F0280 EZ402U	320	600	28.00	28/1	4000	7000	1.7	1	61	12
214	135	203	3.0	1.6	PHA522F0280 EZ502U	320	600	28.00	28/1	4000	7000	5.3	1	61	13
214	151	219	3.4	1.4	PHA522F0280 EZ404U	320	600	28.00	28/1	4000	7000	3.1	1	61	14
240	53	65	1.4	4.1	PHA522F0250 EZ401U	200	600	25.00	25/1	3700	6500	1.2	1	71	11
240	79	102	2.0	2.8	PHA522F0250 EZ501U	320	600	25.00	25/1	3700	6500	3.1	1	71	12
240	81	114	2.1	2.7	PHA522F0250 EZ402U	320	600	25.00	25/1	3700	6500	1.9	1	71	12
240	121	181	3.1	1.8	PHA522F0250 EZ502U	320	600	25.00	25/1	3700	6500	5.4	1	71	13
240	121	184	3.1	1.8	PHA522F0250 EZ701U	320	600	25.00	25/1	3700	6500	8.7	1	71	15
240	135	195	3.4	1.6	PHA522F0250 EZ404U	320	600	25.00	25/1	3700	6500	3.2	1	71	14
240	144	246	3.7	1.5	PHA522F0250 EZ503U	320	600	25.00	25/1	3700	6500	7.8	1	71	15
300	63	82	2.2	3.5	PHA522F0200 EZ501U	300	600	20.00	20/1	3300	6000	3.2	1	71	12
300	65	91	2.3	3.4	PHA522F0200 EZ402U	300	600	20.00	20/1	3300	6000	2.0	1	71	12
300	97	145	3.4	2.3	PHA522F0200 EZ502U	320	600	20.00	20/1	3300	6000	5.5	1	71	13
300	97	147	3.4	2.3	PHA522F0200 EZ701U	320	600	20.00	20/1	3300	6000	8.8	1	71	15
300	108	156	3.8	2.0	PHA522F0200 EZ404U	320	600	20.00	20/1	3300	6000	3.3	1	71	14
300	115	197	4.1	1.9	PHA522F0200 EZ503U	320	600	20.00	20/1	3300	6000	7.9	1	71	15
375	51	65	2.6	4.2	PHA522F0160 EZ501U	240	600	16.00	16/1	3300	6000	3.2	1	65	12
375	52	73	2.7	4.0	PHA522F0160 EZ402U	240	600	16.00	16/1	3300	6000	1.9	1	65	12



5 PHA planetary geared motors

5.2 Selection tables



n_{2N}	M_{2N}	$M_{2,0}$	a_{th}	S	Type	M_{2acc}	M_{2NOT}	i	i_{exakt}	n_{1max} DB	n_{1max} ZB	J_1	$\Delta\varphi_2$	C_2	m
[rpm]	[Nm]	[Nm]				[Nm]	[Nm]			[rpm]	[rpm]	[10 ⁻⁴ kgm ²]	[arcmin]	[Nm/ arcmin]	[kg]
PHA5 ($n_{1N} = 6000$ rpm, $M_{2acc,max} = 320$ Nm)															
375	77	116	4.0	2.7	PHA522F0160 EZ502U	320	600	16.00	16/1	3300	6000	5.5	1	65	13
375	77	118	4.0	2.7	PHA522F0160 EZ701U	300	600	16.00	16/1	3300	6000	8.8	1	65	15
375	86	125	4.5	2.4	PHA522F0160 EZ404U	320	600	16.00	16/1	3300	6000	3.3	1	65	14
375	92	158	4.8	2.3	PHA522F0160 EZ503U	320	600	16.00	16/1	3300	6000	7.9	1	65	15
375	107	213	5.6	2.0	PHA522F0160 EZ702U	320	600	16.00	16/1	3300	6000	14	1	65	18
600	33	42	2.0	3.0	PHA521F0100 EZ501U	150	500	10.00	10/1	3300	6000	3.1	1	55	9.5
600	50	75	3.1	1.9	PHA521F0100 EZ502U	250	500	10.00	10/1	3300	6000	5.4	1	55	11
600	50	76	3.1	1.9	PHA521F0100 EZ701U	190	500	10.00	10/1	3300	6000	8.7	1	55	13
600	60	102	3.7	1.6	PHA521F0100 EZ503U	250	500	10.00	10/1	3300	6000	7.8	1	55	13
600	69	137	4.3	1.4	PHA521F0100 EZ702U	250	500	10.00	10/1	3300	6000	14	1	55	15
857	35	52	3.2	4.2	PHA521F0070 EZ502U	210	600	7.000	7/1	3000	6000	5.7	1	77	11
857	35	53	3.2	4.2	PHA521F0070 EZ701U	130	600	7.000	7/1	3000	6000	9.0	1	77	13
857	42	71	3.8	3.5	PHA521F0070 EZ503U	270	600	7.000	7/1	3000	6000	8.1	1	77	13
857	48	96	4.4	3.0	PHA521F0070 EZ702U	270	600	7.000	7/1	3000	6000	14	1	77	15
PHA7 ($n_{1N} = 2000$ rpm, $M_{2acc,max} = 700$ Nm)															
400	210	317	16	2.1	PHA721F0050 EZ805U	700	1400	5.000	5/1	2200	5000	135	1	184	54
500	168	254	21	2.6	PHA721F0040 EZ805U	700	1370	4.000	4/1	1900	4000	137	1	185	54
PHA7 ($n_{1N} = 3000$ rpm, $M_{2acc,max} = 700$ Nm)															
43	280	306	0.9	1.6	PHA722F0700 EZ501U	650	1240	70.00	70/1	3700	6500	3.1	1	142	18
60	200	219	1.1	2.2	PHA722F0500 EZ501U	700	1400	50.00	50/1	3700	6500	3.1	1	142	18
60	344	372	1.9	1.3	PHA722F0500 EZ502U	700	1400	50.00	50/1	3700	6500	5.4	1	142	19
60	344	386	1.9	1.3	PHA722F0500 EZ701U	700	1400	50.00	50/1	3700	6500	8.7	1	142	21
75	160	175	1.2	2.8	PHA722F0400 EZ501U	600	1370	40.00	40/1	3700	6500	3.1	1	126	18
75	275	298	2.1	1.6	PHA722F0400 EZ502U	700	1370	40.00	40/1	3700	6500	5.4	1	126	19
75	275	309	2.1	1.6	PHA722F0400 EZ701U	700	1370	40.00	40/1	3700	6500	8.7	1	126	21
75	361	413	2.7	1.2	PHA722F0400 EZ503U	700	1370	40.00	40/1	3700	6500	7.8	1	126	21
86	140	153	1.3	3.1	PHA722F0350 EZ501U	520	1400	35.00	35/1	3700	6500	3.2	1	146	18
86	241	260	2.2	1.8	PHA722F0350 EZ502U	700	1400	35.00	35/1	3700	6500	5.5	1	146	19
86	241	270	2.2	1.8	PHA722F0350 EZ701U	650	1400	35.00	35/1	3700	6500	8.8	1	146	21
86	316	361	2.9	1.4	PHA722F0350 EZ503U	700	1400	35.00	35/1	3700	6500	7.9	1	146	21
86	391	469	3.6	1.1	PHA722F0350 EZ702U	700	1400	35.00	35/1	3700	6500	14	1	146	23
86	439	521	4.1	1.0	PHA722F0350 EZ505U	700	1400	35.00	35/1	3700	6500	12	1	146	23
107	112	122	1.4	3.9	PHA722F0280 EZ501U	420	1370	28.00	28/1	3700	6500	3.3	1	131	18
107	193	208	2.5	2.3	PHA722F0280 EZ502U	700	1370	28.00	28/1	3700	6500	5.6	1	131	19
107	193	216	2.5	2.3	PHA722F0280 EZ701U	520	1370	28.00	28/1	3700	6500	8.9	1	131	21
107	253	289	3.3	1.7	PHA722F0280 EZ503U	700	1370	28.00	28/1	3700	6500	8.0	1	131	21
107	312	375	4.0	1.4	PHA722F0280 EZ702U	700	1370	28.00	28/1	3700	6500	14	1	131	23
107	352	417	4.5	1.3	PHA722F0280 EZ505U	700	1370	28.00	28/1	3700	6500	13	1	131	23
120	100	109	1.5	4.4	PHA722F0250 EZ501U	370	1400	25.00	25/1	3500	6000	3.6	1	149	18
120	172	186	2.6	2.6	PHA722F0250 EZ502U	700	1400	25.00	25/1	3500	6000	5.9	1	149	19
120	172	193	2.6	2.6	PHA722F0250 EZ701U	470	1400	25.00	25/1	3500	6000	9.2	1	149	21
120	226	258	3.4	2.0	PHA722F0250 EZ503U	700	1400	25.00	25/1	3500	6000	8.3	1	149	21
120	279	335	4.3	1.6	PHA722F0250 EZ702U	700	1400	25.00	25/1	3500	6000	14	1	149	23
120	314	372	4.8	1.4	PHA722F0250 EZ505U	700	1400	25.00	25/1	3500	6000	13	1	149	23
120	384	484	5.9	1.1	PHA722F0250 EZ703U	700	1400	25.00	25/1	3500	6000	22	1	149	25
150	138	149	2.9	3.2	PHA722F0200 EZ502U	580	1400	20.00	20/1	3000	5000	6.3	1	150	19
150	138	154	2.9	3.2	PHA722F0200 EZ701U	370	1400	20.00	20/1	3000	5000	9.6	1	150	21
150	180	206	3.9	2.4	PHA722F0200 EZ503U	700	1400	20.00	20/1	3000	5000	8.7	1	150	21
150	223	268	4.8	2.0	PHA722F0200 EZ702U	700	1400	20.00	20/1	3000	5000	15	1	150	23
150	251	298	5.4	1.8	PHA722F0200 EZ505U	700	1400	20.00	20/1	3000	5000	13	1	150	23
150	307	387	6.5	1.4	PHA722F0200 EZ703U	700	1400	20.00	20/1	3000	5000	23	1	150	25
188	110	119	3.3	4.0	PHA722F0160 EZ502U	460	1330	16.00	16/1	3000	5000	6.4	1	136	19
188	110	124	3.3	4.0	PHA722F0160 EZ701U	300	1370	16.00	16/1	3000	5000	9.7	1	136	21
188	144	165	4.3	3.0	PHA722F0160 EZ503U	640	1330	16.00	16/1	3000	5000	8.8	1	136	21
188	179	214	5.3	2.5	PHA722F0160 EZ702U	610	1370	16.00	16/1	3000	5000	15	1	136	23
188	201	238	6.0	2.2	PHA722F0160 EZ505U	700	1370	16.00	16/1	3000	5000	13	1	136	23
188	246	310	7.3	1.8	PHA722F0160 EZ703U	700	1370	16.00	16/1	3000	5000	23	1	136	25
188	317	449	9.5	1.4	PHA722F0160 EZ705U	700	1370	16.00	16/1	3000	5000	35	1	136	31
300	71	80	2.0	3.7	PHA721F0100 EZ701U	190	1000	10.00	10/1	3000	5000	9.2	1	117	17

PHA

5 PHA planetary geared motors

5.2 Selection tables



STÖBER

n_{2N}	M_{2N}	$M_{2,0}$	a_{in}	S	Type	M_{2acc}	M_{2NOT}	i	i_{exakt}	n_{1max}	n_{1max}	J_1	$\Delta\varphi_2$	C_2	m
[rpm]	[Nm]	[Nm]				[Nm]	[Nm]			DB	ZB	[10^{-4} kgm ²]	[arcmin]	[Nm/arcmin]	[kg]
PHA7 (n_{1N} = 3000 rpm, M_{2acc,max} = 700 Nm)															
300	115	138	3.2	2.3	PHA721F0100 EZ702U	390	1000	10.00	10/1	3000	5000	14	1	117	19
300	158	200	4.3	1.7	PHA721F0100 EZ703U	500	1000	10.00	10/1	3000	5000	22	1	117	21
300	204	290	5.6	1.3	PHA721F0100 EZ705U	500	1000	10.00	10/1	3000	5000	35	1	117	27
300	214	356	5.9	1.2	PHA721F0100 EZ802U	500	1000	10.00	10/1	3000	5000	59	1	117	35
429	81	97	3.3	4.8	PHA721F0070 EZ702U	280	1240	7.000	7/1	2500	5000	15	1	160	19
429	111	140	4.5	3.5	PHA721F0070 EZ703U	440	1240	7.000	7/1	2500	5000	23	1	160	21
429	143	203	5.9	2.7	PHA721F0070 EZ705U	650	1240	7.000	7/1	2500	5000	35	1	160	27
429	150	249	6.1	2.6	PHA721F0070 EZ802U	650	1240	7.000	7/1	2500	5000	59	1	160	35
600	79	100	6.8	4.9	PHA721F0050 EZ703U	310	890	5.000	5/1	2200	5000	24	1	184	21
600	102	145	8.8	3.8	PHA721F0050 EZ705U	500	1400	5.000	5/1	2200	5000	37	1	184	27
600	107	178	9.2	3.6	PHA721F0050 EZ802U	480	1400	5.000	5/1	2200	5000	61	1	184	35
600	128	231	11	3.0	PHA721F0050 EZ803U	700	1400	5.000	5/1	2200	5000	86	1	184	41
750	82	116	11	4.7	PHA721F0040 EZ705U	400	1370	4.000	4/1	1900	4000	39	1	185	27
750	86	142	12	4.5	PHA721F0040 EZ802U	380	1370	4.000	4/1	1900	4000	63	1	185	35
750	102	185	14	3.8	PHA721F0040 EZ803U	560	1370	4.000	4/1	1900	4000	88	1	185	41
PHA7 (n_{1N} = 4500 rpm, M_{2acc,max} = 700 Nm)															
129	309	498	2.9	1.4	PHA722F0350 EZ505U	700	1400	35.00	35/1	3700	6500	12	1	146	23
161	247	398	3.2	1.8	PHA722F0280 EZ505U	700	1370	28.00	28/1	3700	6500	13	1	131	23
161	315	521	4.1	1.4	PHA722F0280 EZ703U	700	1370	28.00	28/1	3700	6500	22	1	131	25
180	221	356	3.4	2.0	PHA722F0250 EZ505U	700	1400	25.00	25/1	3500	6000	13	1	149	23
180	281	465	4.3	1.6	PHA722F0250 EZ703U	700	1400	25.00	25/1	3500	6000	22	1	149	25
225	177	285	3.8	2.5	PHA722F0200 EZ505U	700	1400	20.00	20/1	3000	5000	13	1	150	23
225	225	372	4.8	2.0	PHA722F0200 EZ703U	700	1400	20.00	20/1	3000	5000	23	1	150	25
281	141	228	4.2	3.1	PHA722F0160 EZ505U	700	1370	16.00	16/1	3000	5000	13	1	136	23
281	156	513	4.7	2.8	PHA722F0160 EZ802U	700	1370	16.00	16/1	3000	5000	59	1	136	39
281	180	298	5.4	2.4	PHA722F0160 EZ703U	700	1370	16.00	16/1	3000	5000	23	1	136	25
281	244	446	7.3	1.8	PHA722F0160 EZ705U	700	1370	16.00	16/1	3000	5000	35	1	136	31
450	101	331	3.2	2.3	PHA721F0100 EZ802U	500	1000	10.00	10/1	3000	5000	59	1	117	35
450	116	192	3.6	2.0	PHA721F0100 EZ703U	500	1000	10.00	10/1	3000	5000	22	1	117	21
450	157	288	4.9	1.5	PHA721F0100 EZ705U	500	1000	10.00	10/1	3000	5000	35	1	117	27
643	71	232	3.3	4.8	PHA721F0070 EZ802U	650	1240	7.000	7/1	2500	5000	59	1	160	35
643	81	134	3.8	4.1	PHA721F0070 EZ703U	440	1240	7.000	7/1	2500	5000	23	1	160	21
643	110	202	5.2	3.0	PHA721F0070 EZ705U	650	1240	7.000	7/1	2500	5000	35	1	160	27
900	79	144	7.7	4.3	PHA721F0050 EZ705U	500	1400	5.000	5/1	2200	5000	37	1	184	27
PHA7 (n_{1N} = 6000 rpm, M_{2acc,max} = 700 Nm)															
86	221	286	0.7	2.0	PHA722F0700 EZ501U	650	1240	70.00	70/1	3700	6500	3.1	1	142	18
120	158	205	0.9	2.8	PHA722F0500 EZ501U	700	1400	50.00	50/1	3700	6500	3.1	1	142	18
120	242	363	1.3	1.8	PHA722F0500 EZ502U	700	1400	50.00	50/1	3700	6500	5.4	1	142	19
120	242	367	1.3	1.8	PHA722F0500 EZ701U	700	1400	50.00	50/1	3700	6500	8.7	1	142	21
120	288	493	1.6	1.5	PHA722F0500 EZ503U	700	1400	50.00	50/1	3700	6500	7.8	1	142	21
150	126	164	1.1	2.9	PHA722F0400 EZ501U	600	1370	40.00	40/1	3700	6500	3.1	1	126	18
150	193	290	1.7	1.9	PHA722F0400 EZ502U	700	1370	40.00	40/1	3700	6500	5.4	1	126	19
150	193	294	1.7	1.9	PHA722F0400 EZ701U	700	1370	40.00	40/1	3700	6500	8.7	1	126	21
150	231	394	2.1	1.6	PHA722F0400 EZ503U	700	1370	40.00	40/1	3700	6500	7.8	1	126	21
150	268	532	2.4	1.4	PHA722F0400 EZ702U	700	1370	40.00	40/1	3700	6500	14	1	126	23
171	111	143	1.0	4.0	PHA722F0350 EZ501U	520	1400	35.00	35/1	3700	6500	3.2	1	146	18
171	169	254	1.6	2.6	PHA722F0350 EZ502U	700	1400	35.00	35/1	3700	6500	5.5	1	146	19
171	169	257	1.6	2.6	PHA722F0350 EZ701U	650	1400	35.00	35/1	3700	6500	8.8	1	146	21
171	202	345	1.9	2.2	PHA722F0350 EZ503U	700	1400	35.00	35/1	3700	6500	7.9	1	146	21
171	234	465	2.2	1.9	PHA722F0350 EZ702U	700	1400	35.00	35/1	3700	6500	14	1	146	23
214	89	115	1.1	5.0	PHA722F0280 EZ501U	420	1370	28.00	28/1	3700	6500	3.3	1	131	18
214	135	203	1.7	3.2	PHA722F0280 EZ502U	700	1370	28.00	28/1	3700	6500	5.6	1	131	19
214	135	206	1.7	3.2	PHA722F0280 EZ701U	520	1370	28.00	28/1	3700	6500	8.9	1	131	21
214	161	276	2.1	2.7	PHA722F0280 EZ503U	700	1370	28.00	28/1	3700	6500	8.0	1	131	21
214	187	372	2.4	2.3	PHA722F0280 EZ702U	700	1370	28.00	28/1	3700	6500	14	1	131	23
240	121	181	1.8	3.6	PHA722F0250 EZ502U	700	1400	25.00	25/1	3500	6000	5.9	1	149	19
240	121	184	1.8	3.6	PHA722F0250 EZ701U	470	1400	25.00	25/1	3500	6000	9.2	1	149	21
240	144	246	2.2	3.1	PHA722F0250 EZ503U	700	1400	25.00	25/1	3500	6000	8.3	1	149	21
240	167	332	2.6	2.6	PHA722F0250 EZ702U	700	1400	25.00	25/1	3500	6000	14	1	149	23



5 PHA planetary geared motors

5.2 Selection tables



n_{2N} [rpm]	M_{2N} [Nm]	$M_{2,0}$ [Nm]	a_{th}	S	Type	M_{2acc} [Nm]	M_{2NOT} [Nm]	i	i_{exakt}	n_{1max} DB [rpm]	n_{1max} ZB [rpm]	J_1 [10 ⁻⁴ kgm ²]	$\Delta\varphi_2$ [arcmin]	C_2 [Nm/ arcmin]	m [kg]
PHA8 ($n_{1N} = 2000$ rpm, $M_{2acc,max} = 2000$ Nm)															
80	1016	1537	5.9	1.2	PHA822F0250 EZ805U	2000	3200	25.00	25/1	3000	5500	135	1	484	82
100	813	1229	6.6	1.5	PHA822F0200 EZ805U	2000	3200	20.00	20/1	2500	4500	137	1	459	82
125	650	984	8.4	1.7	PHA822F0160 EZ805U	2000	3150	16.00	16/1	2500	4500	137	1	452	82
200	420	635	4.1	1.9	PHA821F0100 EZ805U	1200	2400	10.00	10/1	2500	4000	136	1	317	73
286	294	444	5.0	3.4	PHA821F0070 EZ805U	1380	2770	7.000	7/1	2000	4000	140	1	474	73
400	210	317	7.5	4.8	PHA821F0050 EZ805U	980	2870	5.000	5/1	1700	4000	148	1	566	73
500	168	254	12	4.8	PHA821F0040 EZ805U	790	2310	4.000	4/1	1500	3500	157	1	634	73
PHA8 ($n_{1N} = 3000$ rpm, $M_{2acc,max} = 2000$ Nm)															
30	688	772	0.8	1.2	PHA822F1000 EZ701U	1200	2400	100.0	100/1	3300	6000	9.0	1	305	44
43	482	540	0.7	2.1	PHA822F0700 EZ701U	1300	2770	70.00	70/1	3300	6000	9.1	1	421	44
43	781	937	1.2	1.3	PHA822F0700 EZ702U	1600	2770	70.00	70/1	3300	6000	14	1	421	47
60	344	386	0.7	3.6	PHA822F0500 EZ701U	930	3200	50.00	50/1	3300	6000	9.1	1	436	44
60	558	670	1.1	2.2	PHA822F0500 EZ702U	1910	3200	50.00	50/1	3300	6000	14	1	436	47
60	767	967	1.6	1.6	PHA822F0500 EZ703U	2000	3200	50.00	50/1	3300	6000	22	1	436	49
60	990	1404	2.0	1.3	PHA822F0500 EZ705U	2000	3200	50.00	50/1	3300	6000	35	1	436	54
75	275	309	1.0	3.7	PHA822F0400 EZ701U	740	3150	40.00	40/1	3300	6000	9.2	1	418	44
75	446	536	1.6	2.3	PHA822F0400 EZ702U	1530	3150	40.00	40/1	3300	6000	14	1	418	47
75	614	774	2.2	1.6	PHA822F0400 EZ703U	1920	3150	40.00	40/1	3300	6000	22	1	418	49
75	792	1123	2.8	1.3	PHA822F0400 EZ705U	1920	3150	40.00	40/1	3300	6000	35	1	418	54
75	830	1380	3.0	1.2	PHA822F0400 EZ802U	1920	3150	40.00	40/1	3300	6000	59	1	418	63
86	391	469	1.4	3.2	PHA822F0350 EZ702U	1330	3200	35.00	35/1	3300	6000	15	1	448	47
86	537	677	1.9	2.3	PHA822F0350 EZ703U	2000	3200	35.00	35/1	3300	6000	23	1	448	49
86	693	983	2.4	1.8	PHA822F0350 EZ705U	2000	3200	35.00	35/1	3300	6000	35	1	448	54
86	726	1208	2.6	1.7	PHA822F0350 EZ802U	2000	3200	35.00	35/1	3300	6000	59	1	448	63
107	312	375	1.7	3.5	PHA822F0280 EZ702U	1070	3150	28.00	28/1	3300	6000	15	1	435	47
107	430	542	2.4	2.6	PHA822F0280 EZ703U	1690	3150	28.00	28/1	3300	6000	23	1	435	49
107	555	786	3.1	2.0	PHA822F0280 EZ705U	2000	3150	28.00	28/1	3300	6000	35	1	435	54
107	581	966	3.2	1.9	PHA822F0280 EZ802U	2000	3150	28.00	28/1	3300	6000	59	1	435	63
120	279	335	1.6	4.5	PHA822F0250 EZ702U	950	3200	25.00	25/1	3000	5500	16	1	484	47
120	384	484	2.2	3.3	PHA822F0250 EZ703U	1510	3200	25.00	25/1	3000	5500	24	1	484	49
120	495	702	2.9	2.5	PHA822F0250 EZ705U	2000	3200	25.00	25/1	3000	5500	37	1	484	54
120	518	863	3.0	2.4	PHA822F0250 EZ802U	2000	3200	25.00	25/1	3000	5500	61	1	484	63
120	618	1121	3.6	2.0	PHA822F0250 EZ803U	2000	3200	25.00	25/1	3000	5500	86	1	484	69
150	307	387	2.5	4.1	PHA822F0200 EZ703U	1210	3200	20.00	20/1	2500	4500	26	1	459	49
150	396	562	3.2	3.2	PHA822F0200 EZ705U	1930	3200	20.00	20/1	2500	4500	38	1	459	54
150	415	690	3.4	3.0	PHA822F0200 EZ802U	1860	3200	20.00	20/1	2500	4500	62	1	459	63
150	495	897	4.0	2.5	PHA822F0200 EZ803U	2000	3200	20.00	20/1	2500	4500	88	1	459	69
188	246	310	3.2	4.5	PHA822F0160 EZ703U	970	2760	16.00	16/1	2500	4500	26	1	452	49
188	317	449	4.1	3.5	PHA822F0160 EZ705U	1550	3150	16.00	16/1	2500	4500	39	1	452	54
188	332	552	4.3	3.3	PHA822F0160 EZ802U	1490	3150	16.00	16/1	2500	4500	63	1	452	63
188	396	717	5.1	2.8	PHA822F0160 EZ803U	2000	3150	16.00	16/1	2500	4500	88	1	452	69
300	214	356	2.4	3.3	PHA821F0100 EZ802U	960	2400	10.00	10/1	2500	4000	62	1	317	54
300	255	463	2.8	2.7	PHA821F0100 EZ803U	1200	2400	10.00	10/1	2500	4000	87	1	317	60
429	179	324	3.5	4.9	PHA821F0070 EZ803U	970	2770	7.000	7/1	2000	4000	91	1	474	60
PHA8 ($n_{1N} = 4500$ rpm, $M_{2acc,max} = 2000$ Nm)															
90	563	930	1.3	2.0	PHA822F0500 EZ703U	2000	3200	50.00	50/1	3300	6000	22	1	436	49
90	763	1395	1.8	1.4	PHA822F0500 EZ705U	2000	3200	50.00	50/1	3300	6000	35	1	436	54
113	391	1283	1.6	2.3	PHA822F0400 EZ802U	1920	3150	40.00	40/1	3300	6000	59	1	418	63
113	450	744	1.8	2.0	PHA822F0400 EZ703U	1920	3150	40.00	40/1	3300	6000	22	1	418	49
113	610	1116	2.5	1.4	PHA822F0400 EZ705U	1920	3150	40.00	40/1	3300	6000	35	1	418	54
129	342	1123	1.2	3.7	PHA822F0350 EZ802U	2000	3200	35.00	35/1	3300	6000	59	1	448	63
129	394	651	1.4	3.2	PHA822F0350 EZ703U	2000	3200	35.00	35/1	3300	6000	23	1	448	49
129	534	977	1.9	2.3	PHA822F0350 EZ705U	2000	3200	35.00	35/1	3300	6000	35	1	448	54
161	273	898	1.5	4.0	PHA822F0280 EZ802U	2000	3150	28.00	28/1	3300	6000	59	1	435	63
161	315	521	1.8	3.5	PHA822F0280 EZ703U	1690	3150	28.00	28/1	3300	6000	23	1	435	49
161	427	781	2.4	2.6	PHA822F0280 EZ705U	2000	3150	28.00	28/1	3300	6000	35	1	435	54
180	281	465	1.6	4.4	PHA822F0250 EZ703U	1510	3200	25.00	25/1	3000	5500	24	1	484	49
180	381	698	2.2	3.3	PHA822F0250 EZ705U	2000	3200	25.00	25/1	3000	5500	37	1	484	54

PHA

5 PHA planetary geared motors

5.2 Selection tables



STÖBER

n_{2N}	M_{2N}	$M_{2,0}$	a_{in}	S	Type	M_{Zacc}	M_{2NOT}	i	i_{exakt}	n_{1max}	n_{1max}	J_1	$\Delta\varphi_2$	C_2	m
[rpm]	[Nm]	[Nm]				[Nm]	[Nm]			DB	ZB	[10 ⁻⁴ kgm ²]	[arcmin]	[Nm/ arcmin]	[kg]
PHA8 ($n_{1N} = 4500$ rpm, $M_{Zacc,max} = 2000$ Nm)															
225	305	558	2.5	4.1	PHA822F0200 EZ705U	1930	3200	20.00	20/1	2500	4500	38	1	459	54
281	244	446	3.2	4.5	PHA822F0160 EZ705U	1550	3150	16.00	16/1	2500	4500	39	1	452	54
PHA8 ($n_{1N} = 6000$ rpm, $M_{Zacc,max} = 1910$ Nm)															
60	484	735	0.6	1.7	PHA822F1000 EZ701U	1200	2400	100.0	100/1	3300	6000	9.0	1	305	44
86	339	514	0.5	3.0	PHA822F0700 EZ701U	1300	2770	70.00	70/1	3300	6000	9.1	1	421	44
86	469	931	0.7	2.1	PHA822F0700 EZ702U	1600	2770	70.00	70/1	3300	6000	14	1	421	47
120	242	367	0.6	4.1	PHA822F0500 EZ701U	930	3200	50.00	50/1	3300	6000	9.1	1	436	44
120	335	665	0.9	3.0	PHA822F0500 EZ702U	1910	3200	50.00	50/1	3300	6000	14	1	436	47
150	193	294	0.9	4.1	PHA822F0400 EZ701U	740	3150	40.00	40/1	3300	6000	9.2	1	418	44
150	268	532	1.2	3.0	PHA822F0400 EZ702U	1530	3150	40.00	40/1	3300	6000	14	1	418	47
PHA9 ($n_{1N} = 2000$ rpm, $M_{Zacc,max} = 5000$ Nm)															
42	1951	2951	1.9	1.5	PHA932F0480 EZ805U	4500	9000	48.00	48/1	2800	4500	137	1	1084	109
48	1707	2582	2.0	1.8	PHA932F0420 EZ805U	4500	9000	42.00	42/1	2800	4500	138	1	1099	109
50	1626	2459	2.3	1.7	PHA932F0400 EZ805U	4610	9220	40.00	40/1	2800	4500	136	1	1057	109
63	1301	1967	2.3	2.3	PHA932F0320 EZ805U	4610	9220	32.00	32/1	2800	4500	138	1	1112	109
67	1219	1844	2.4	2.5	PHA932F0300 EZ805U	4500	9000	30.00	30/1	2500	4000	144	1	1115	109
71	1138	1721	2.5	2.6	PHA932F0280 EZ805U	5000	10000	28.00	28/1	2800	4500	139	1	1147	109
83	975	1475	2.7	3.1	PHA932F0240 EZ805U	4500	9000	24.00	24/1	2200	3500	151	1	1125	109
100	813	1229	3.0	3.7	PHA932F0200 EZ805U	3810	10000	20.00	20/1	2500	4000	146	1	1188	109
111	732	1107	3.1	4.1	PHA932F0180 EZ805U	3430	9000	18.00	18/1	1800	3000	177	1	1135	109
125	650	984	3.3	4.6	PHA932F0160 EZ805U	3050	8960	16.00	16/1	2200	3500	155	1	1212	109
PHA9 ($n_{1N} = 3000$ rpm, $M_{Zacc,max} = 4610$ Nm)															
50	1244	2070	0.9	2.4	PHA932F0600 EZ802U	4500	9000	60.00	60/1	2800	4500	61	1	1060	90
50	1484	2690	1.0	2.0	PHA932F0600 EZ803U	4500	9000	60.00	60/1	2800	4500	86	1	1060	96
63	995	1656	1.0	3.0	PHA932F0480 EZ802U	4460	9000	48.00	48/1	2800	4500	62	1	1084	90
63	1187	2152	1.2	2.5	PHA932F0480 EZ803U	4500	9000	48.00	48/1	2800	4500	88	1	1084	96
71	871	1449	1.0	3.4	PHA932F0420 EZ802U	3910	9000	42.00	42/1	2800	4500	64	1	1099	90
71	1039	1883	1.2	2.9	PHA932F0420 EZ803U	4500	9000	42.00	42/1	2800	4500	89	1	1099	96
75	830	1380	1.4	2.8	PHA932F0400 EZ802U	3720	9220	40.00	40/1	2800	4500	61	1	1057	90
75	990	1793	1.6	2.4	PHA932F0400 EZ803U	4610	9220	40.00	40/1	2800	4500	87	1	1057	96
94	664	1104	1.3	4.0	PHA932F0320 EZ802U	2980	9220	32.00	32/1	2800	4500	63	1	1112	90
94	792	1434	1.6	3.4	PHA932F0320 EZ803U	4320	9220	32.00	32/1	2800	4500	88	1	1112	96
100	622	1035	1.2	4.8	PHA932F0300 EZ802U	2790	9000	30.00	30/1	2500	4000	69	1	1115	90
100	742	1345	1.5	4.0	PHA932F0300 EZ803U	4050	9000	30.00	30/1	2500	4000	94	1	1115	96
107	693	1255	1.5	4.3	PHA932F0280 EZ803U	3780	10000	28.00	28/1	2800	4500	90	1	1147	96
PHA10 ($n_{1N} = 2000$ rpm, $M_{Zacc,max} = 7500$ Nm)															
33	2438	3688	1.4	1.7	PHA1032F0600 EZ805U	6910	13820	60.00	60/1	2800	4500	136	1	1602	124
42	1951	2951	1.3	2.4	PHA1032F0480 EZ805U	6910	13820	48.00	48/1	2800	4500	137	1	1657	124
48	1707	2582	1.3	2.9	PHA1032F0420 EZ805U	7500	15000	42.00	42/1	2800	4500	139	1	1691	124
67	1219	1844	1.6	4.1	PHA1032F0300 EZ805U	5720	15000	30.00	30/1	2500	4000	145	1	1730	124
83	975	1475	1.9	4.7	PHA1032F0240 EZ805U	4580	13430	24.00	24/1	2200	3500	153	1	1753	124
PHA10 ($n_{1N} = 3000$ rpm, $M_{Zacc,max} = 6910$ Nm)															
50	1244	2070	0.8	2.8	PHA1032F0600 EZ802U	5580	13820	60.00	60/1	2800	4500	61	1	1602	105
50	1484	2690	1.0	2.4	PHA1032F0600 EZ803U	6910	13820	60.00	60/1	2800	4500	87	1	1602	111
63	995	1656	0.8	4.0	PHA1032F0480 EZ802U	4460	13820	48.00	48/1	2800	4500	63	1	1657	105
63	1187	2152	0.9	3.4	PHA1032F0480 EZ803U	6470	13820	48.00	48/1	2800	4500	88	1	1657	111
71	1039	1883	0.8	4.8	PHA1032F0420 EZ803U	5660	15000	42.00	42/1	2800	4500	90	1	1691	111



5.3 Dimensional drawings

In this chapter you can find the dimensions of the geared motors.

There is a dimensional drawing for every possible shaft/housing design, each with the tables for gear unit dimensions, motor dimensions and geared motor dimensions.

Dimensions can exceed the specifications of ISO 2768-mK due to casting tolerances or accumulation of individual tolerances.

We reserve the right to make dimensional changes due to ongoing technical development.

You can download CAD models of our standard drives at <http://cad.stoeber.de>.

Combination options and the dimensions of forced ventilated geared motors can be found at <http://cad.stoeber.de>.



5.3.1 F shaft design (flange shaft)

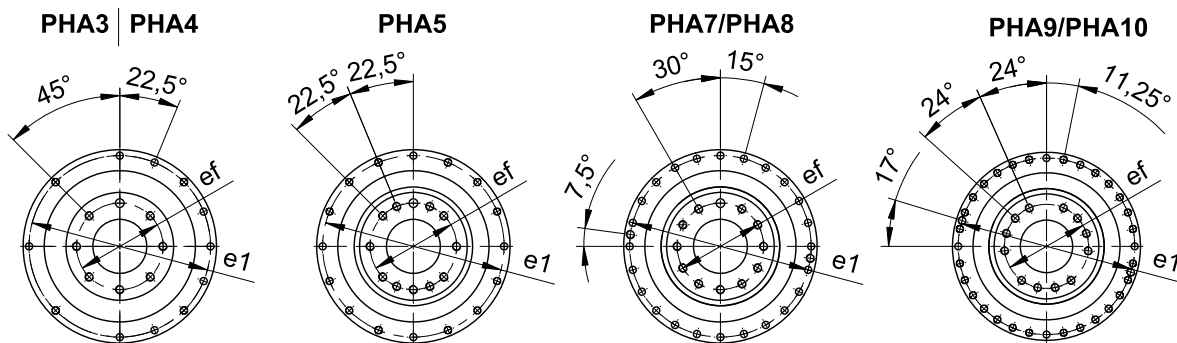
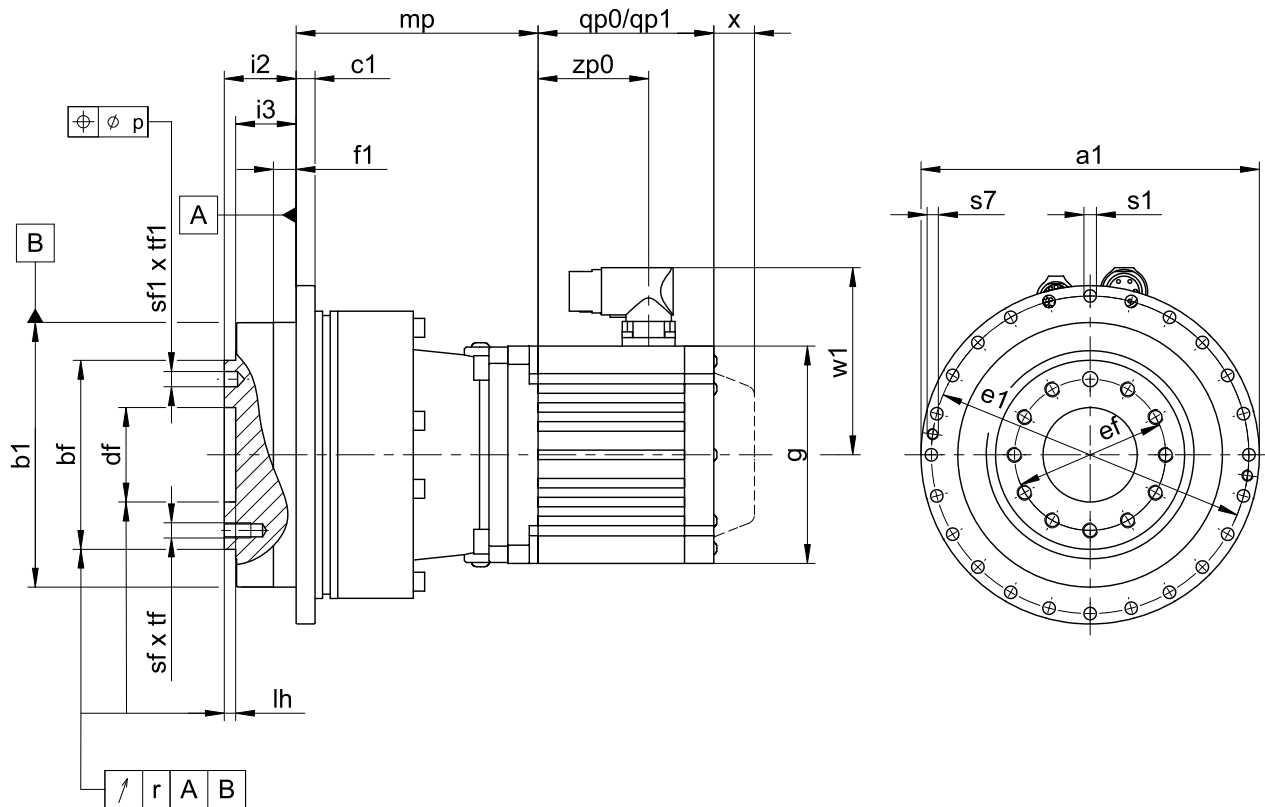

qp0	Applies to motors without brake.	qp1	Applies to motors with brake.
x	Applies to encoders using an optical measuring concept.	w1	For variation for One Cable Solution (OCS), see Chapter [22.4]

Dimensions of gear units

Type	$\varnothing a1$	$\varnothing b1$	$\varnothing bf$	c1	$\varnothing df$	$\varnothing e1$	$\varnothing ef$	f1	i2	i3	lh	p	r	$\varnothing s1$	s7	sf	sf1	tf	tf1
PHA321	86 _{h7}	64 _{h7}	40 _{h7}	4	20.0 ^{H6}	79	31.5	7	19.5	16.5	4	0.02	0.020	4.5	-	M5	5 ^{H7}	7	3
PHA322	86 _{h7}	64 _{h7}	40 _{h7}	4	20.0 ^{H6}	79	31.5	7	19.5	16.5	4	0.02	0.020	4.5	-	M5	5 ^{H7}	7	3
PHA421	118 _{h7}	90 _{h7}	63 _{h7}	7	31.5 ^{H6}	109	50.0	10	30.0	24.0	6	0.02	0.020	5.5	-	M6	6 ^{H7}	11	7
PHA422	118 _{h7}	90 _{h7}	63 _{h7}	7	31.5 ^{H6}	109	50.0	10	30.0	24.0	6	0.02	0.020	5.5	-	M6	6 ^{H7}	11	7
PHA521	145 _{h7}	110 _{h7}	80 _{h7}	8	40.0 ^{H6}	135	63.0	10	29.0	23.0	6	0.02	0.020	5.5	-	M6	6 ^{H7}	11	7
PHA522	145 _{h7}	110 _{h7}	80 _{h7}	8	40.0 ^{H6}	135	63.0	10	29.0	23.0	6	0.02	0.020	5.5	-	M6	6 ^{H7}	11	7
PHA721	179 _{h7}	140 _{h7}	100 _{h7}	10	50.0 ^{H6}	168	80.0	12	38.0	32.0	6	0.02	0.025	6.6	-	M8	8 ^{H7}	14	7
PHA722	179 _{h7}	140 _{h7}	100 _{h7}	10	50.0 ^{H6}	168	80.0	12	38.0	32.0	6	0.02	0.025	6.6	-	M8	8 ^{H7}	14	7
PHA821	247 _{h7}	200 _{h7}	160 _{h7}	12	80.0 ^{H6}	233	125.0	15	50.0	42.0	8	0.02	0.030	9.0	M10	M10	10 ^{H7}	18	10
PHA822	247 _{h7}	200 _{h7}	160 _{h7}	12	80.0 ^{H6}	233	125.0	15	50.0	42.0	8	0.02	0.030	9.0	M10	M10	10 ^{H7}	18	10
PHA932	300	255 _{h7}	180 _{h7}	18	90.0 ^{H6}	280	140.0	20	66.0	55.0	12	-	0.030	13.5	M8	M16	-	24	-
PHA1032	330	285 _{h7}	200 _{h7}	20	95.0 ^{H6}	310	160.0	20	75.0	60.0	10	-	0.040	13.5	M10	M20	-	30	-



Dimensions of motors

Type	□g	qp0	qp1	w1	x	zp0
EZ301U	72	90	130.0	55.5	21	54.5
EZ302U	72	112	152.0	55.5	21	76.5
EZ303U	72	134	174.0	55.5	21	98.5
EZ401U	98	98	146.5	91.0	22	56.0
EZ402U	98	123	171.5	91.0	22	81.0
EZ404U	98	173	221.5	91.0	22	131.0
EZ501U	115	93	147.5	100.0	22	58.5
EZ502U	115	118	172.5	100.0	22	83.5
EZ503U	115	143	197.5	100.0	22	108.5
EZ505U	115	193	247.5	100.0	22	158.5
EZ701U	145	102	161.0	115.0	22	64.0
EZ702U	145	127	186.0	115.0	22	89.0
EZ703U	145	152	211.0	115.0	22	114.0
EZ705U	145	207	266.0	134.0	22	165.0
EZ802U	190	197	274.0	156.5	22	143.0
EZ803U	190	238	315.0	156.5	22	184.0
EZ805U	190	320	397.0	156.5	22	266.0

PHA

Dimensions of geared motors

Type	EZ3 mp	EZ4 mp	EZ5 mp	EZ7 mp	EZ8 mp
PHA321	51.0	48.0	–	–	–
PHA322	87.5	–	–	–	–
PHA421	–	51.0	53.5	–	–
PHA422	103.0	99.5	102.0	–	–
PHA521	–	–	57.0	63.0	–
PHA522	–	112.5	115.0	121.0	–
PHA721	–	–	–	68.0	77.0
PHA722	–	–	128.0	134.0	149.0
PHA821	–	–	–	–	99.5
PHA822	–	–	–	169.0	184.0
PHA932	–	–	–	–	249.5
PHA1032	–	–	–	–	257.0



5.4 Type designation

In this chapter, you can find an explanation of the type designation with the associated options. Additional ordering information not included in the type designation can be found at the end of the chapter.

Sample code

PHA	5	2	2	F	0250	EZ401U
-----	---	---	---	---	------	--------

Explanation

Code	Designation	Design
PHA	Type	Low-backlash planetary gear unit
5	Size	5 (example)
2	Generation	Generation 2
3		Generation 3
1	Stages	Single-stage
2		Two-stage
F	Shaft	Flange shaft
0250	Transmission ratio (i x 10)	i = 25 (example)
EZ401U	Motor	EZ synchronous servo motor

In order to complete the type designation, also specify:

- A detailed type designation of the motor, see Chapter [▶ 22]
- For reverse operation of the output shaft at $\pm 20^\circ$ to $\pm 90^\circ$ and horizontal installation, note Chapter [▶ 5.6.4]

5.5 Product description

5.5.1 Installation conditions

The specified torques and forces only apply when attaching gear units on the machine side using screws of quality 12.9. In addition, the gear housing must be adjusted at pilot $\varnothing b1$ (H7).

5.5.2 Lubricants

STÖBER fills the gear units with the amount and type of lubricant specified on the nameplate.

Lubricant filling quantities for gear units, document ID 441871, can be found online at <http://www.stoeber.de>

5.5.3 Other product features

Feature	Value
Max. permitted gear unit temperature (on the surface of the gear unit)	$\leq 90^\circ\text{C}$
Paint	Black RAL 9005
(ATEX) Directive 2014/34/EU	Not suitable
Protection class: ¹	
Gear unit	IP65
Motor	IP56, optionally IP66

¹ Observe the protection class of all the components.



5.5.4 Direction of rotation

The input and output rotate in the same direction.

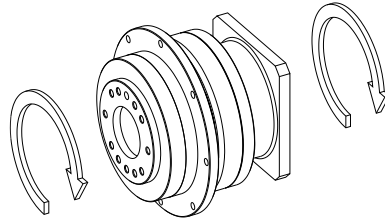

5.6 Project configuration

Project your drive using our SERVOfsoft designing software. You can receive SERVOfsoft for free from your adviser at one of our sales centers. Observe the limit conditions in this chapter to ensure a safe design for your drives.

The formula symbols for values actually present in the application are marked with *.

Formula symbol	Unit	Explanation
a_{th}	–	Parameter for calculating $K_{mot,th}$
ED	%	Duty cycle relative to 20 minutes
fB_{op}	–	Operating mode operating factor
fB_t	–	Run-time operating factor
fB_T	–	Temperature operating factor
F_{2ax}^*	N	Actual axial force at the gear unit output
$F_{2ax,eq}^*$	N	Actual equivalent axial force on the gear unit output
F_{2ax100}	N	Permitted axial force at the gear unit output for $n_{2m} \leq 100$ rpm
F_{2axN}	N	Permitted nominal axial force at the gear unit output
$F_{2rad,acc}$	N	Permitted radial acceleration force at the gear unit output
$F_{2rad,acc}^*$	N	Actual radial acceleration force at the gear unit output
$F_{2rad,acc,1}^*$	N	Actual radial acceleration force at the gear unit output in the first time segment
$F_{2rad,acc,n}^*$	N	Actual radial acceleration force at the gear unit output in the n-th time segment
$F_{2rad,eq}^*$	N	Actual equivalent force at the gear unit output
$F_{2rad100}$	N	Permitted radial force at the gear unit output for $n_{2m} \leq 100$ rpm
F_{2radN}	N	Permitted nominal radial force at the gear unit output
i	–	Gear ratio
$K_{mot,th}$	–	Factor for determining the thermal limit torque
l	mm	Length of the output shaft
L_{10h}	h	Bearing service life
M_{op}	Nm	Torque of motor at the operating point from the motor characteristic curve at n_{1m}^*
$ M_2 $	Nm	Amount of torque on the output
$M_{2,1}^* - M_{2,6}^*$	Nm	Actual torque in the respective time segment (1 to 6)
$M_{2,n}^*$	Nm	Actual torque in the n-th time segment
M_{2acc}	Nm	Maximum permitted acceleration torque on the gear unit output



Formula symbol	Unit	Explanation
M_{2acc}^*	Nm	Actual acceleration torque on the gear unit output
M_{2eff}^*	Nm	Actual effective torque on the gear unit output
M_{2eq}^*	Nm	Equivalent torque present on the gear unit output
M_{2k100}	Nm	Permitted breakdown torque on the gear unit output for $n_{2m} \leq 100$ rpm
M_{2kN}	Nm	Permitted nominal breakdown torque on the gear unit output
M_{2k}^*	Nm	Actual breakdown torque on the gear unit output
$M_{2k,acc}$	Nm	Permitted acceleration breakdown torque on the gear unit output
$M_{2k,acc}^*$	Nm	Actual acceleration breakdown torque on the gear unit output
$M_{2k,acc,1}^*$	Nm	Actual acceleration breakdown torque on the gear unit output in the first time segment
$M_{2k,acc,n}^*$	Nm	Actual acceleration breakdown torque on the gear unit output in the n-th time segment
$M_{2k,eq}^*$	Nm	Actual equivalent breakdown torque on the gear unit output
M_{2N}	Nm	Nominal torque on the gear unit output (relative to n_{1N})
M_{2NOT}	Nm	Gear unit emergency-off torque on the gear unit output for max. 1000 load changes
M_{2NOT}^*	Nm	Actual emergency off torque for the gear unit on the gear unit output
M_{2th}	Nm	Thermal limit torque on the gear unit output
n_{1m}^*	rpm	Actual average input speed
n_{1max}^*	rpm	Actual maximum input speed
n_{1maxDB}	min ⁻¹	Maximum permitted input speed of the gear unit in continuous operation
n_{1maxZB}	min ⁻¹	Maximum permitted input speed of the gear unit in cyclic operation
$ n_2 $	rpm	Value of output speed
n_{2m}^*	rpm	Actual average output speed
$n_{2m,1}^* - n_{2m,6}^*$	rpm	Actual average output speed in the respective time segment (1 to 6)
$n_{2m,n}^*$	rpm	Actual average output speed in the n-th time segment
t	s	Time
$t_1^* - t_6^*$	s	Duration of the respective time segment (1 to 6)
t_n^*	s	Duration of the n-th time segment
S	–	Load value: Quotient of gear unit and motor nominal torque without regard to the thermal performance limit. Represents a value for the reserve of the geared motor.
x_2	mm	Distance of the shaft shoulder to the force application point
y_2	mm	Distance of the shaft axis to the axial force application point
z_2	mm	Distance of the shaft shoulder to the middle of the output bearing

5.6.1 Calculation of the operating point

Check the following conditions for operating points other than the nominal point M_{2N} specified in the selection tables.

$$n_{1m}^* \leq \frac{n_{1maxDB}}{fB_T}$$



$$n_{1\max} \leq \frac{n_{1\max ZB}}{fB_T}$$

$$M_{2\text{eff}} \leq M_{2\text{th}}$$

$$M_{2\text{acc}} \leq M_{2\text{acc}}$$

$$M_{2\text{NOT}} \leq M_{2\text{NOT}}$$

$$M_{2\text{eq}} \leq M_{2N} \cdot \frac{S}{fB_{\text{op}} \cdot fB_t}$$

The values for $n_{1\max DB}$, $n_{1\max ZB}$, $M_{2\text{acc}}$, $M_{2\text{NOT}}$, M_{2N} and S can be found in the selection tables.

The values for fB_T , fB_{op} and fB_t can be found in the corresponding tables in this chapter.

Calculate the thermal limit torque $M_{2\text{th}}$ for a duty cycle > 50%.

Example of cycle sequence

The following calculations are based on a representation of the power taken from the output based in accordance with the following example:

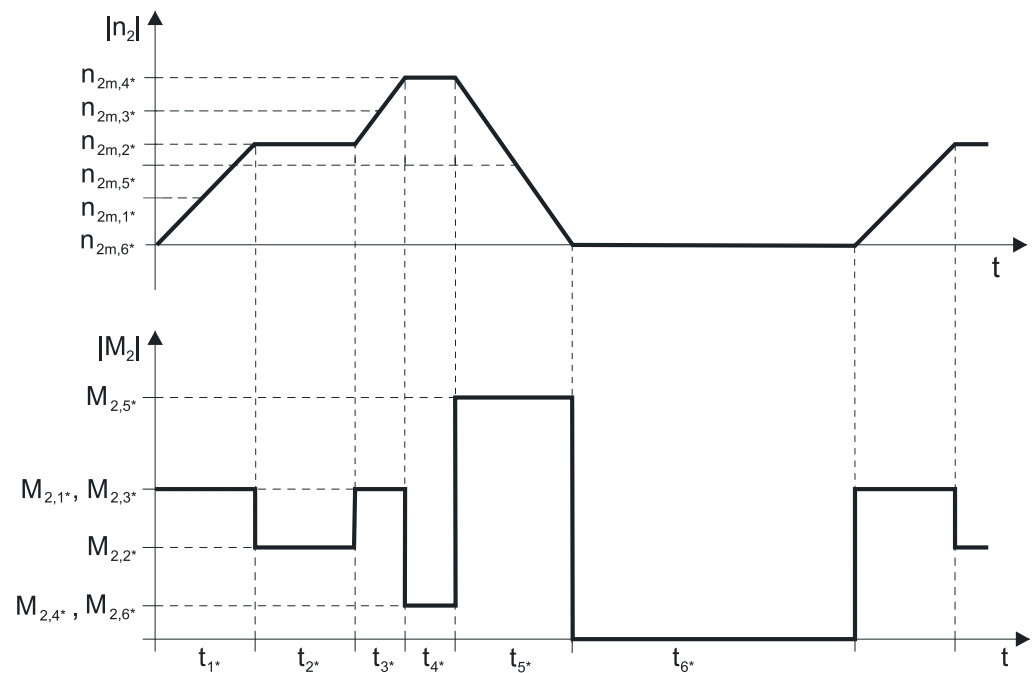

Calculation of the actual average input speed

$$n_{1m} = n_{2m} \cdot i$$

$$n_{2m} = \frac{|n_{2m,1}^*| \cdot t_1^* + \dots + |n_{2m,n}^*| \cdot t_n^*}{t_1^* + \dots + t_n^*}$$

If $t_1^* + \dots + t_5^* \geq 20$ min, calculate n_{2m} without the rest phase t_6^* .

The values for the ratio i can be found in the selection tables.

Calculation of the actual effective torque

$$M_{2\text{eff}} = \sqrt{\frac{t_1^* \cdot M_{2,1}^{*2} + \dots + t_n^* \cdot M_{2,n}^{*2}}{t_1^* + \dots + t_n^*}}$$



Calculation of the actual equivalent torque

$$M_{2eq*} = \sqrt[3]{\frac{|n_{2m,1*}| \cdot t_{1*} \cdot |M_{2,1*}|^3 + \dots + |n_{2m,n*}| \cdot t_{n*} \cdot |M_{2,n*}|^3}{|n_{2m,1*}| \cdot t_{1*} + \dots + |n_{2m,n*}| \cdot t_{n*}}}$$

Calculation of the thermal limit torque

Calculate the thermal limit torque M_{2th} for a duty cycle $ED > 50\%$ and the actual average input speed n_{1m*} . (At $K_{mot,th} \leq 0$ you must reduce the average input speed n_{1m*} accordingly or select another geared motor size.)

$$M_{2th} = M_{op} \cdot i \cdot K_{mot,th}$$

$$K_{mot,th} = 0,93 - \frac{a_{th}}{1000} \cdot fB_T \cdot \left(\frac{n_{1m*}}{1000}\right)^3$$

The values for i and a_{th} can be found in the selection tables.

The values for fB_T can be found in the corresponding table in this chapter.

The value for the torque of the motor at operating point M_{op} with the determined average input speed n_{1m*} can be found in the motor curve of Chapter [22.3](#). Note the size, nominal speed n_N and cooling type of the motor. The figure below shows an example of reading the torque M_{op} of a motor with convection cooling at the operating point.

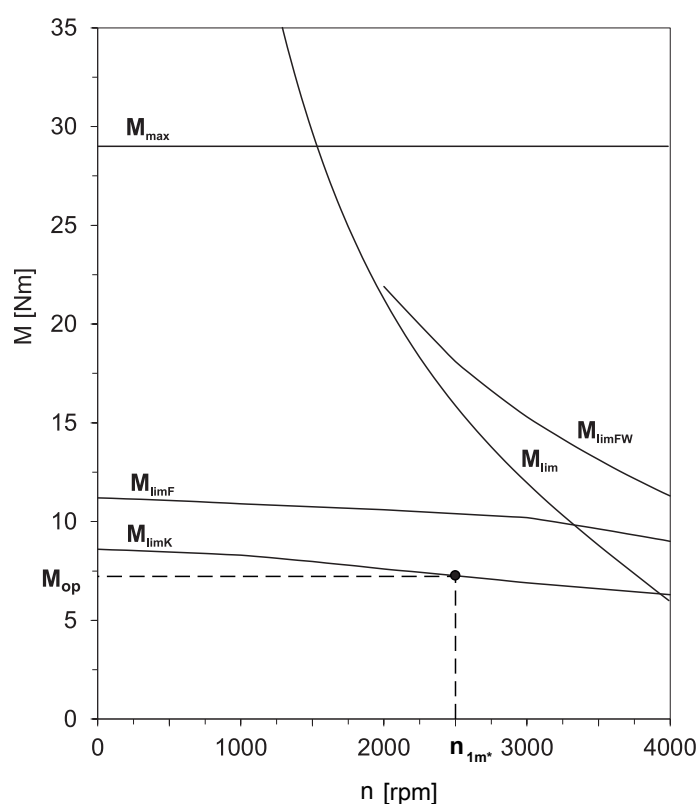

Operating factors

Operating mode	fB_{op}
Uniform continuous operation	1.00
Cyclic operation	1.00
Reversing load cyclic operation	1.00



Run time		fB _t
Daily run time ≤ 8 h		1.00
Daily run time ≤ 16 h		1.15
Daily run time ≤ 24 h		1.20

Temperature		fB _T
Motor cooling	Surrounding temperature	
Motor with forced ventilation	≤ 20 °C	0.9
	≤ 30 °C	1.0
	≤ 40 °C	1.15
Motor with convection cooling	≤ 20 °C	1.0
	≤ 30 °C	1.1
	≤ 40 °C	1.25

Notes

- The maximum permitted gear unit temperature (see the "Other product features" chapter) must not be exceeded. Doing so may result in damage to the geared motor.
- For braking from full speed (for example when the power fails or when setting up the machine), note the permitted gear unit torques (M_{2acc}, M_{2NOT}) in the selection tables.

5.6.2 Permitted shaft loads for the output shaft

The values specified in the tables apply to the permitted shaft loads:

- For shaft dimensions in accordance with the catalog
- For output speeds n_{2m*} ≤ 100 rpm (F^{2axN} = F_{2ax100}; F_{2radN} = F_{2rad100}; M_{2kN} = M_{2k100})
- Only if transverse forces on the gear unit are supported via its pilots (housing, flange shaft)

Permitted shaft loads

Type	z ₂ [mm]	F _{2ax100} [N]	F _{2rad100} [N]	F _{2rad,acc} [N]	M _{2k100} [Nm]	M _{2k,acc} [Nm]
PHA3	62.0	1650	1613	1613	100	100
PHA4	84.0	2150	3095	3571	260	300
PHA5	97.0	4150	4536	4897	440	475
PHA7	88.0	6150	17045	17045	1500	1500
PHA8	126.0	10050	27778	27778	3500	3500
PHA9	155.0	33000	48387	70968	7500	11000
PHA10	171.0	50000	51462	73099	8800	12500

For other output speeds, download diagrams at <http://products.stoeber.de>.

The following applies to output speeds n_{2m*} > 100 rpm:

$$F_{2axN} = \frac{F_{2ax100}}{\sqrt[3]{\frac{n_{2m*}}{100 \text{ rpm}}}}$$

$$F_{2radN} = \frac{F_{2rad100}}{\sqrt[3]{\frac{n_{2m*}}{100 \text{ rpm}}}}$$

$$M_{2kN} = \frac{M_{2k100}}{\sqrt[3]{\frac{n_{2m*}}{100 \text{ rpm}}}}$$

The values for F_{2ax100}, F_{2rad100} and M_{2k100} can be found in the table "Permitted shaft loads" in this chapter.

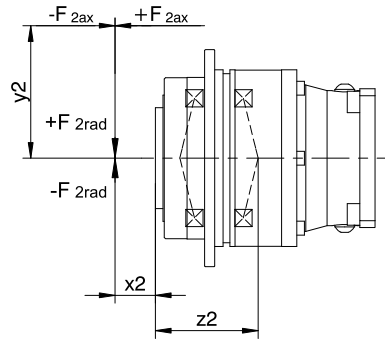

Fig. 1: Force application points

The permitted transverse forces can be determined from the permitted breakdown torque M_{2kN} and $M_{2k,acc}$. The actual transverse forces must not exceed the permitted transverse forces. The permitted transverse forces are based on the end of the hollow shaft ($x_2 = 0$).

$$M_{2k,acc} = \frac{2 \cdot F_{2ax} \cdot y_2 + F_{2rad,acc} \cdot (x_2 + z_2)}{1000} \leq M_{2k,acc}$$

For applications with multiple axial and/or radial forces, you must add the forces as vectors.

In the event of EMERGENCY OFF operation (max. 1000 load changes), you can multiply the permitted forces and torques for F_{2ax100} , $F_{2rad100}$ and M_{2k100} by a factor of two.

Also note the calculation for equivalent values:

$$M_{2k,eq} = \sqrt[3]{\frac{|n_{2m,1}| \cdot t_{1^*} \cdot |M_{2k,acc,1^*}|^3 + \dots + |n_{2m,n}| \cdot t_{n^*} \cdot |M_{2k,acc,n^*}|^3}{|n_{2m,1}| \cdot t_{1^*} + \dots + |n_{2m,n}| \cdot t_{n^*}}} \leq M_{2kN}$$

$$F_{2rad,eq} = \sqrt[3]{\frac{|n_{2m,1}| \cdot t_{1^*} \cdot |F_{2rad,acc,1^*}|^3 + \dots + |n_{2m,n}| \cdot t_{n^*} \cdot |F_{2rad,acc,n^*}|^3}{|n_{2m,1}| \cdot t_{1^*} + \dots + |n_{2m,n}| \cdot t_{n^*}}} \leq F_{2radN}$$

$$F_{2ax,eq} \leq F_{2axN}$$

The following apply to the bearing service life L_{10h} (duty cycle $\leq 40\%$):

$$L_{10h} > 10000 \text{ h with } 1 < M_{2kN}/M_{2k^*} < 1.25$$

$$L_{10h} > 20000 \text{ h with } 1.25 < M_{2kN}/M_{2k^*} < 1.5$$

$$L_{10h} > 30000 \text{ h with } 1.5 < M_{2kN}/M_{2k^*}$$

For different duty cycles:

$$L_{10h} > L_{10h(ED=40\%)} \cdot \frac{40\%}{ED}$$

5.6.3 Radial shaft seal rings

Leak-proofness

Our gear units are equipped with high-quality radial shaft seal rings and checked for leak-proofness. However, a leak cannot be fully ruled out over the length of use of the gear unit. If you use the gear unit with goods incompatible with the lubricant, you must take measures to prevent direct contact with the gear unit lubricant in case of a leak.



5.6.4 Reverse operation

PHA

To ensure lubrication of circulating geared parts during cyclic reverse operation from $\pm 20^\circ$ to $\pm 90^\circ$, pay careful attention to the position of the output shaft if the gear unit is installed horizontally as shown in the images below.

The images show the center position of reverse operation.

Cyclic reverse operation $\leq \pm 20^\circ$ on request.

Sizes 3, 4, 5, 8	Size 7	Sizes 9, 10
1 Position of the positioning hole: bottom	1 Position of the positioning hole: as shown in the image	1 Position of the fastening thread: as shown in the image

5.7 Additional documentation

Additional documentation related to the product can be found at <http://www.stoeber.de/en/download>

Enter the ID of the documentation in the Search... field.

Documentation	ID
Operating manual for planetary gear units and motors	441957
Lubricant filling quantities for gear units	441871