

Krauss-Maffei HD/BD helix dryers



Krauss-Maffei HD/BD helix dryers

Table of contents



Krauss-Maffei helix dryer, HD	3
Process advantages	4
Krauss-Maffei helix dryer, BD	5
Process advantages	6
Helix dryer, HD/BD mobile	7
Process advantages	8
Systems	9
Process automation	10
Technical data	11
Test centers	12
Services	13
Company profile	14
Product lines	15

Krauss-Maffei HD helix dryer

Flexible mixing and drying

Crucial requirements in modern plants for the production of chemical or pharmaceutical agents are gentle and efficient process control, minimum product loss, high flexibility, contamination-free product handling, as well as cleaning validation.

The Krauss-Maffei helix dryer achieves efficient mixing of friable bulk goods by using the helix mixer, a top-driven, central mixer. For processing sticky products, a special segmented mixer design is available. By heating the vessel wall and the mixer, the HD becomes a high-performance contact dryer for thermal solid/liquid separation at low temperatures and under vacuum. The optimized clearance between the mixer and the vessel wall in combination with central product discharge at the bottom provide fast, easy emptying with minimum product retention.

A variety of different peripheral units, such as an integrated or top-mounted dust filter, isolation valves with no dead spots for filling, discharge and sampling, CIP spraying devices, as well as inertizing and purge gas systems, are available to meet the most demanding requirements. Krauss-Maffei helix dryers are mainly operated as vacuum contact dryers. The product range contains stationary devices for all sizes, mobile devices for laboratory and test operation, as well as systems with mobile vessels and central dryer stations. With this wide product range, we accommodate individual demands and can offer tailor-made solutions.



Krauss-Maffei helix dryer, HD 1250 stationary

Main applications

- Amino acids
- Antibiotics
- APIs
- Fine chemicals
- Foodstuffs
- Pharmaceutical intermediates
- Plastics

Process data

Operating principle

Discontinuous vacuum contact drying, tempering, mixing, homogenizing

Consistency of product

Free-flowing bulk goods, centrifuge-wet or filter-wet

Product transport

Mechanical, with helix mixer

Average particle size

Up to 5 mm

Heat transfer medium

Water/steam/thermal oil

Krauss-Maffei HD helix dryer

Process advantages



Manhole with integrated filter

The Krauss-Maffei HD helix dryer with a segmented helical mixer offers considerable advantages for gentle product handling free of contamination, vacuum contact drying, complete emptying, and fully automatic cleaning. Components that have proved effective in many other Krauss-Maffei dryers are now optimizing operation of the Krauss-Maffei helix dryer.

Your benefits

■ **Gentle processing**

Constant lifting of the product at the vessel wall and continuous backflow into the center of the vessel provide efficient and, at the same time, gentle mixing of the dry, friable material. The shear forces arising are minimal with this kind of mixing. The variable speed drive allows maximum flexibility in order to optimize the process for different products.

■ **High thermal transfer**

The constant movement of the product over the entire heated vessel wall minimizes internal resistance to thermal transfer. The high flow of heat arises only from thermal transfer to the product, not from mechanical friction.



Central product discharge

■ **Preventing lump formation**

The continuous circulating movement within the bulk product prevents agglomerates from forming. As a result, there is no 'snow-ball' effect.

■ **Vacuum contact drying**

The design makes use of all of the advantages of vacuum contact drying, such as low thermal load in the product, high thermal efficiency, safe processing of explosive or toxic substances, or simple solvent recovery.

■ **Optimum discharge of products**

A central outlet and discharging while the mixer is running ensure almost complete product discharge.

■ **No product contamination**

Drive and bearing assembly are completely separated from the process area. The shaft seal is a floating ring type, positioned centrally above the product.

■ **Fully automatic CIP cleaning**

Spray devices in the vessel cover and at the internal fixtures ensure that all internal surfaces are cleaned with cleaning fluid.



Drive unit

■ **Compact design**

The integrated vapor precipitator reduces dust debris, and the filter is easy to change.

■ **Faster final drying**

down to the ppm range by introducing carrier gas through special deodorizing nozzles directly above the product discharge.

■ **Full inspection**

thanks to easy access via covers that can be opened fully, or through large manhole covers.

■ **Easy maintenance**

as all drive components are accessible from the outside. The shaft seal at the mixer can be serviced without removing the drive unit or mixer.

Krauss-Maffei BD helix dryer

In order to make use of the advantages of the Krauss-Maffei HD helix dryer as well in handling difficult products, the dryer design has been enhanced in cooperation with renowned European pharmaceutical companies.

The result - the Krauss-Maffei BD helix dryer with its special vessel design and combined helix-anchor mixer - also fulfils the crucial requirements for products that are difficult to mix in modern plants for the production of chemical or pharmaceutical agents.

The innovative design replaces the conical vessel with a rounded bowl, thus eliminating any critical areas with low peripheral speeds, poor blending, product adhering to the mixer segments, and limited product discharge can be avoided. As with the standard version of the Krauss-Maffei helix dryer, the BD series is also available in a mobile and a stationary design for optimum adjustment to process conditions.

Process data

Operating principle

Vacuum contact drying, mixing, homogenizing

Operating mode

Batch-type

Consistency of wet product

Free-flowing, centrifuge or filter cake, pasty and sticky products

Product conveying

Mechanical, by integrated helical and anchor shaped mixer

Particle size

Up to 5 mm

Heat transfer medium

Water/steam/thermal oil

Drying temperature

150°C max.

Retention time

30 min-20 h

Main applications

- Amino acids
- Antibiotics
- APIs
- Fine chemicals
- Foodstuffs
- Pharmaceutical intermediates
- Plastics

Materials of construction

- Stainless steel
- Nickel-based alloys
- Special materials

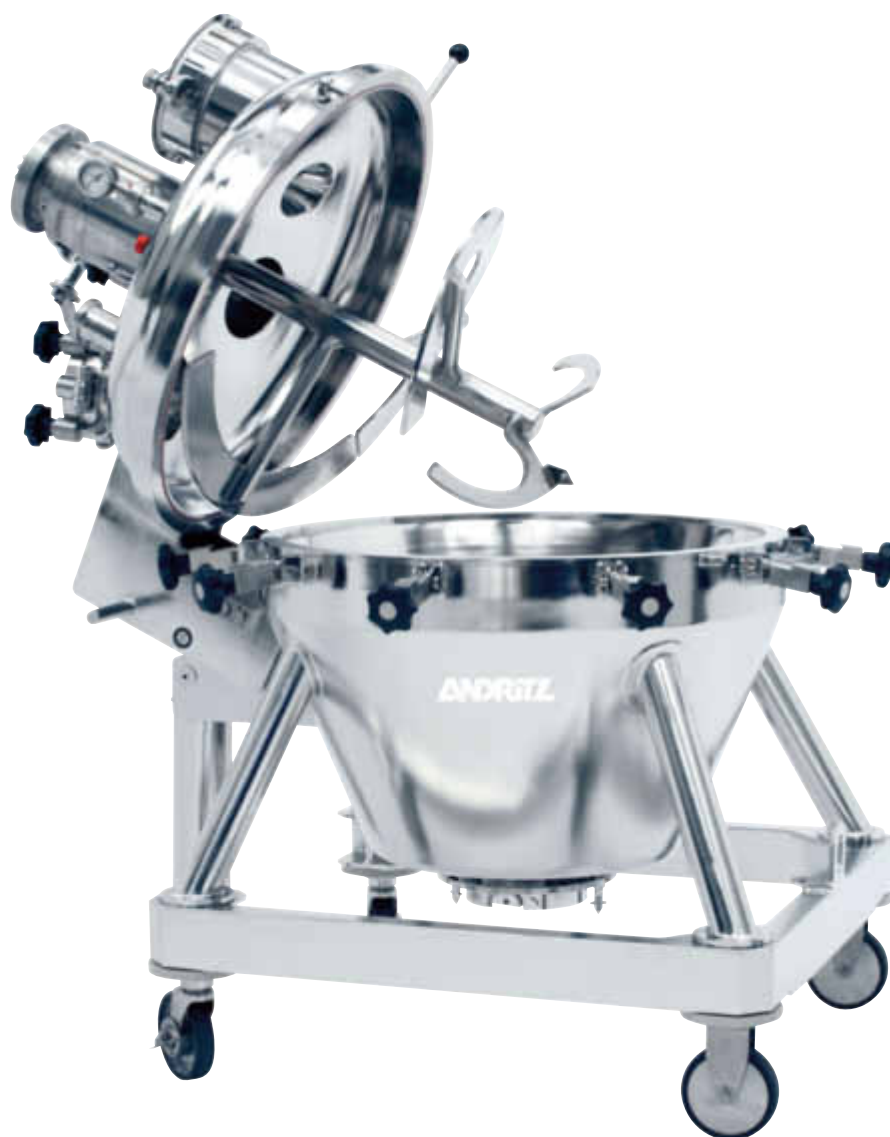

Krauss-Maffei BD helix dryer, mobile

Krauss-Maffei BD helix dryer

Process advantages



Bowl design

■ Optimum blending

Areas with poor blending characteristics in the lower part of the vessel are eliminated by using an anchor-shaped mixer in the bowl-design dryer. Its special design allows for processing of products with poor rheological properties without them sticking to the mixer.

■ Mixing of pasty products

Installation of flow baffles or fast-rotating choppers above the anchor-shaped mixer allow processing of pasty products.

■ Reduced crusting

Compared to traditional helix dryers, the BD series uses a robust, shorter mixer shaft with insignificant deflection, even when mixing sticky products. Thus, clearance between the mixer and the vessel can be kept to a minimum.

■ Minimum product retention

on the mixer due to a reduced number of mixer segments and therefore a reduced surface area.

■ Less space required

The overall height of the dryer can be reduced significantly with the bowl-design vessel.

■ Simple inspection

due to the fully opening lid with mixer, which does not require more clearance to the vessel wall.

■ Increased heat transfer area

Mixer with anchor and helix is available in double-walled design for heating with heat transfer fluid.



Fully heatable mixer helix

■ Fast product discharge

If the product discharge is located off center, the mixer itself assists product discharge.

■ Sampling

Vertical discharge is achieved by positioning the sampling points low down in the bowl-shaped vessel.

Krauss-Maffei HD/BD mobile helix dryer

Mobile mixing and drying



Krauss-Maffei helix dryer, BD 160 mobile

Separation processes require independent mechanical and thermal separation devices to achieve the best possible product quality. However, a lot of space is required for processing smaller product batches as this equipment is stationary and arranged in series. Constant, manually controlled refilling of the product from one process step to the next results in product loss and risk of contamination.

The Krauss-Maffei HD/BD mobile system consisting of a stationary peeler centrifuge, a mobile vessel, as well as a stationary drying and filling station, fulfills all requirements for closed product handling, flexibility/ multi-purpose use, optimum process flow, optimized space requirement, clean room installation, as well as optimized investment and operating costs.



Krauss-Maffei helix dryer, HD 160 mobile

The special feature of the Krauss-Maffei HD/BD mobile helix dryer for processing batches up to 500 l bulk volume is separation of the process component for product feed from the drive unit. For filling purposes, the vessel - a heatable conical vacuum vessel with lid and a central helix mixer - is flanged directly to the solids discharge at the centrifuge. After filling, the closed vessel is moved from the centrifuge to the dryer station. Here, it is connected to the drive unit and the power system for vacuum drying. A lifting device lifts the vessel up to the dryer station. The packing drum for the dried product is connected directly to the central product discharge.

Helix dryer

Advantages

- **Optimum process control**

by using individual vessels for the different process steps in filtration and drying.

- **Product handling without contamination and losses**

The use of special docking systems prevents any contamination of the product or the environment. The product is processed in the vessel only. Any losses due to filling the product into or out of other vessels can thus be avoided.

- **Less space requirement**

Filtration, drying and filling are possible in one single clean room.

- **Full inspection**

Simple and full inspection of all parts in contact with the product is possible by lifting the dryer lid with mixer at the dryer station. As an alternative, the dryer lid can be designed for opening.

- **Larger heat transfer area**

The anchor and helix mixers are available in double-walled design for heating with heat transfer fluid.



Closed system



Full inspection



Suitable for CIP



Systems

ANDRITZ KMPT develops and delivers all peripheral units that are necessary for operation of Krauss-Maffei helix dryers, such as vacuum, heating, cleaning and solid handling systems, in modular design. The individual modules consist of devices/machines, instruments, sensors and pipework.

Engineering costs are reduced and time for installation and commissioning is shortened by avoiding interfaces and due to ANDRITZ KMPT's decades of experience in finding solutions for mechanical and thermal separation tasks. ANDRITZ KMPT is your single contact for the entire system.



Filling at centrifuge



Connecting to drying station



At lifting station for discharge

ANDRITZ KMPT

Process automation

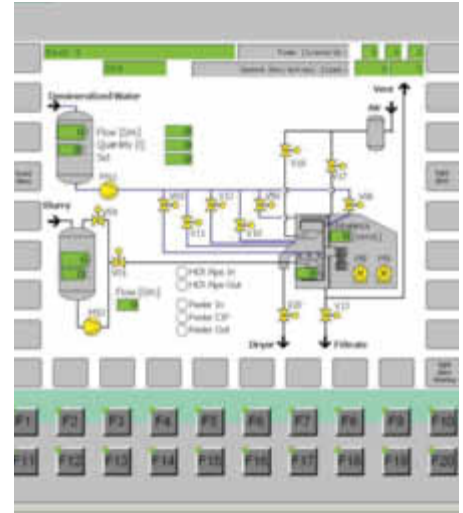
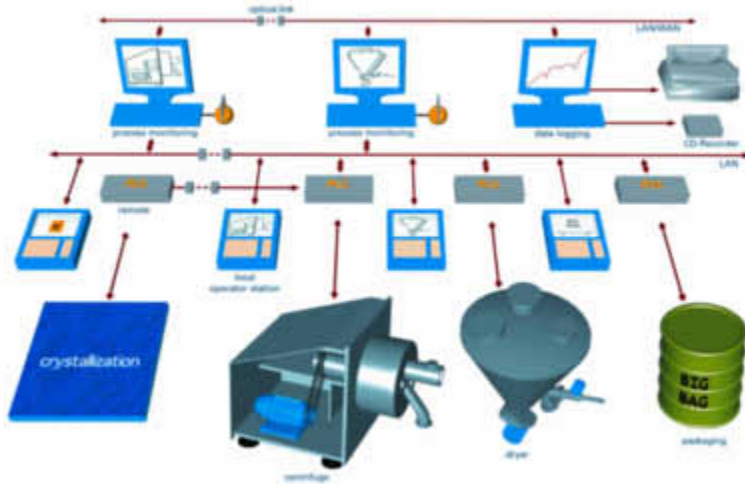

Perfection in process engineering requires perfection in process automation.

The superior performance of our process equipment is based on perfecting the interface between equipment hardware, electrical components, electronics, informatics, and process know-how to create an all-encompassing custom-tailored solution for each application. Using intelligent sensors and state-of-the-art communication systems, we control and monitor our machines on a result-oriented basis.

Your benefits:

- Enhanced equipment performance
- Consistent high product quality
- Reduced consumption of utilities
- Optional status diagnostics

Automation of machines

Individual adaptation – we can incorporate the automation concepts for our machine into your existing control system.

Custom concepts

We provide an individually designed service package to fit your specification – from the control of individual units, to incorporation into existing control systems or automation of complete plants ready for operation.

Services

Based on your quality assurance program, we prepare all the required documents for validation and qualification of the automation software and hardware. Our extensive know-how, profound experience, and innovative drive qualify us as your partner for validation of our equipment to meet your production needs.

Machinery directives, ATEX, hazardous location regulations – there are many regulations to be met at the plant site. We are there to serve as your knowledgeable advisor for the safety of your plant.

Krauss-Maffei BD helix dryer

Technical data

Model	Design	Diameter [mm]	Height a [mm]	Height b [mm]	Usable volume [l]	Heating surfaces [m ²]	Drive [kW]
2	lab	400	355	1,000*	2	0.14	0.15
4	lab	400	355	1,000*	4	0.17	0.5
10	lab	500	400	1,200*	10	0.2	1.1
25	mobile/stationary	560	410	1,140*	25	0.3	1.5
50	mobile/stationary	670	460	1,670*	50	0.4	2.2
100	mobile/stationary	800	580	2,040*	100	0.7	3.0
150	mobile/stationary	960	625	2,350*	150	1.0	4.0
300	mobile/stationary	1,170	795	2,882*	300	1.7	5.5
500	stationary	1,330	1,046	2,380	500	2.0	7.5
600	stationary	1,470	1,060	2,490	600	2.7	11.0
800	stationary	1,600	1,090	2,700	800	3.3	15.0
1000	stationary	1,715	1,125	2,830	1,000	4.2	15.0
1500	stationary	1,915	1,300	3,000	1,500	6.5	18.5
2000	stationary	2,115	1,540	3,480	2,000	7.0	22.0
3500	stationary	2,380	1,840	3,730	3,500	10.3	30.0
4500	stationary	2,650	2,350	4,010	4,500	12.9	37.0

*Height with frame

Other sizes and lab-scale equipment on request.

All technical data are approximate and subject to change without notice.

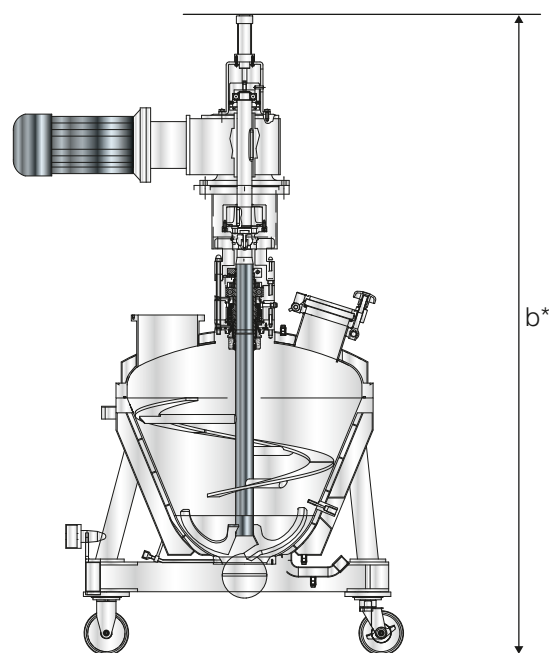
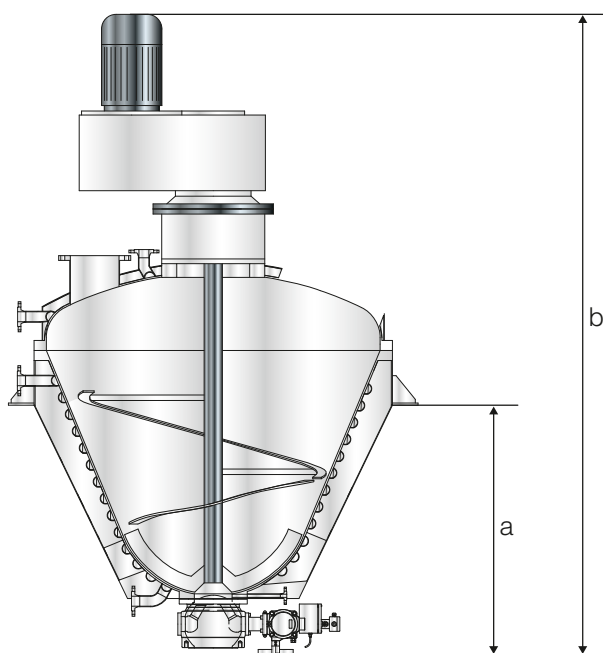

ANDRITZ KMPT

Test centers



Test center in Vierkirchen, Germany



Production works in Florence, USA



Consulting

ANDRITZ KMPT operates fully equipped test centers in Germany and the USA, offering both bench and pilot scale equipment.

Our experienced engineers will consult with you to determine the equipment most appropriate for your product, then will perform the necessary trials to optimize the operating conditions for your process.

Based on these tests, we will provide a complete report which will recommend the best solution for your solid/liquid separation process, including scale-up information for the production equipment.

We can also assist in running long-term trials at your site with equipment from our rental machine pool.

ANDRITZ KMPT

Services



Refurbished equipment

Our goal is to provide our customers with fast and reliable service, from the first process consultation throughout the entire service life of your ANDRITZ KMPT process equipment.

To assist our global customer base, we operate service facilities around the world staffed with experienced, dedicated service teams.

Spare parts

We keep over 6,000 different spare parts and components in stock for you. Our service centers in the USA, the UK, Italy, France, and China, for example, maintain their own spare parts stock to enable faster delivery to your plant site.

Reconditioned units

We maintain a select stock of reconditioned units available for fast delivery from our facility. All machines are fully disassembled, inspected and reconditioned by replacing worn or damaged parts. A final test run validates the mechanical guarantee we provide with our refurbished equipment. With our factory reconditioned units you gain production capacity quickly with minimal capital investment.



Commissioning

Repairs and maintenance

Our service centers are ready to provide you with regularly scheduled maintenance or emergency service at your site. Our experts provide assistance including assembly work, installation support, commissioning, upgrades, repair work, and optimization of your process conditions.

Advisory service

Our customer service team is ready to answer any question concerning machine safety, equipment upgrades, and process optimization.

Installation and commissioning

Our experienced service personnel assists you with the installation and start-up of your equipment.

Remote diagnostics

Using modern communications and diagnostic systems, our customer service is able to offer even faster and more efficient support. Via remote access our specialists receive information on the operating condition of your machine and carry out fault diagnoses. Maximum data security is of course guaranteed at all times. We only access the data from your machine when you give your specific approval for us to do so.



Spare parts

24-hour on-call service

You can reach our skilled and experienced service team around the clock.

Maintenance contracts

We offer you tailor-made, long-term contracts for preventive maintenance of your equipment.

Customer training

We train your operating personnel during commissioning of the plant. In addition, we also offer you seminars for maintenance and operation of our entire line of process equipment. This training can be conducted at our site or yours.

ANDRITZ KMPT

Company profile



The ANDRITZ GROUP

The ANDRITZ GROUP is a globally leading supplier of plants and services for the hydropower, pulp and paper, metals, and other specialized industries. The Group is headquartered in Graz, Austria, and has a staff of approximately 16,100 employees worldwide. ANDRITZ operates over 120 production sites, service, and sales companies all around the world.

ANDRITZ SEPARATION

ANDRITZ SEPARATION is one of the leading global suppliers of plants, equipment, and services for mechanical and thermal solid/liquid separation (coal, ore and mineral processing, chemical, petrochemical, and food industries). The business area's field of activity covers design and manufacture of key components (centrifuges, filter presses, rotating filters, drying plants), as well as erection and start-up of turnkey plants, including automation, safety engineering, and services.

ANDRITZ KMPT

ANDRITZ KMPT has been a world leader and innovator in the chemical process industry for over 75 years. The extensive experience of our engineers comes from testing more than 3,000 products and putting over 9,000 applications to work. Over 500 patents demonstrate our capacity for innovation. This extensive knowledge governs our process and equipment recommendations, all tailored to meet our customers' requirements with an optimum in performance and cost.

ANDRITZ KMPT

Product lines

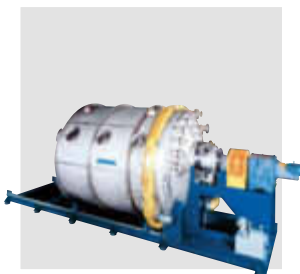

■ Krauss-Maffei centrifuges

With horizontal peeler centrifuges known for reliability, pharma centrifuges designed to meet highest quality standards, innovative vertical basket centrifuges and continuously operating pusher centrifuges, ANDRITZ KMPT has the capability to handle a broad range of separation applications in the chemicals, pharmaceuticals and environmental industries.

■ Krauss-Maffei filters

For vacuum or pressure filtration, our rotary drum and disc filters combine high yield with low production costs in the processing of chemicals, plastics and minerals.

■ Krauss-Maffei dryers

Batch drying in our conical mixer dryer with helical mixing assembly or continuous drying of free-flowing materials in our plate dryer – we offer the right choice of dryers for fine chemical and pharmaceutical producers.

■ ANDRITZ KMPT process systems

We apply our experience and expertise to create fully functional processing modules including peripherals and automation, saving the customer from having to deal with multiple vendors. ANDRITZ KMPT provides all the detailed engineering and reduces installation time with pre-assembled systems.

ANDRITZ stands for ultimate know-how in solid/liquid separation. Our decade-long background in this field and comprehensive technology offering enable us to supply our customers with the best solution for each application, whether in municipal or industrial sewage sludge treatment, the chemical or food industry, or for preparation of minerals and ores.



Food



Chemicals



Minerals



Mining



Environment

ANDRITZ KMPT GmbH

Industriestrasse 1-3
85256 Vierkirchen, Germany
Phone: +49 (0)8139 80299 - 0
kmp@andritz.com

ANDRITZ AG

Stattegger Strasse 18
8045 Graz, Austria
Phone: +43 (316) 6902 0
separation@andritz.com
www.andritz.com