

AWEMA
quality wins

Decorating System Type ARTIST

Automatic Decoration and Wording

Time-consuming and labour-intensive decorating work is performed fully automatically and rapidly by ARTIST. The machine is made up of a state-of-the-art industrial robot and the AWEMA piston dosing system with hydraulic actuator. The AWEMA software combines the robot and the dosing unit. It co-ordinates the motions of the robot with the dosing system controller and offers a technology package especially tailored to dosing tasks. The decorating programs can be saved on diskette or a computer network and can be printed out. The mass is conveyed in a closed circuit directly from the tempering machine to the dosing block or is discharged from a storage hopper.



Application

Decoration
of hollow figure shapes

Decoration
of chocolates, bars, etc.

Free dressing
of chocolate motifs

Wording
on confectionery articles

Decoration
of cakes and baked products

Features

Very simple programming
by teach-in system

Very short product changing
and cleaning times without tools

Network integration with existing
production lines

High dependability and
operational reliability

Fast return on investment

Complies with global safety
standards

Decorating System Type ARTIST

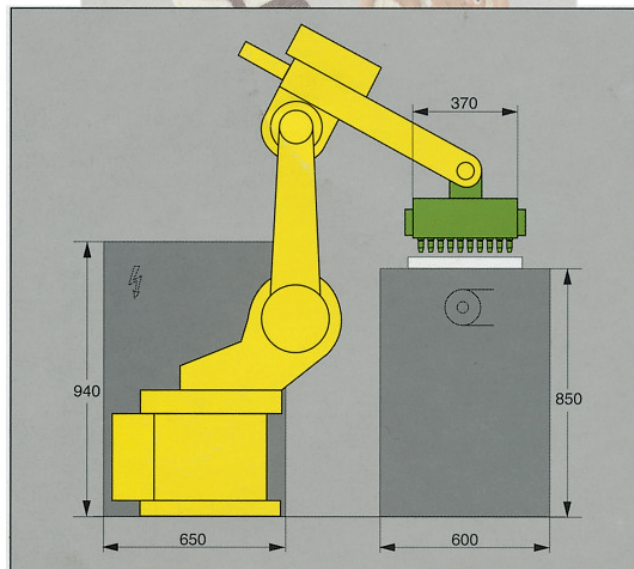

Design

State-of-the-art industrial robot with AC servo-motors

Hydraulic unit with servo-valves for piston actuation

Direct feed from the chocolate tempering machine

Option: heated storage hopper with agitator

Protective housing with electric monitoring system

Repeatability $\pm 0,2$ mm on 6 axes

Working speed up to 500 mm / s

Motor power approx. 3 kW

Hydraulic unit approx. 0.75 kW

Protection IP 64 according to IEC 529 for the dosing system

Food-compatible hydraulic fluid and gear lubricant

Control system

Industrial PC with AWEMA software

Programming through operator panel, no need for any additional hardware

Unlimited number of decorating programs

Plain-text messages on the operator panel

Serial and parallel interfaces, Ethernet



AWEMA AG

Schulstrasse 26 CH-8330 Pfäffikon ZH
Telefon +41 (0) 43 288 70 00
Telefax +41 (0) 43 288 70 27
www.awema.ch e-mail: info@awema.ch