

Model 110S Precision Pressure Transducers with Integrated Temperature Sensor



Description

Developed from the BCM piezoresistive pressure sensor, the 110S pressure transducer is designed for precision pressure measurement in gas metering applications. Thanks to the integrated temperature sensor, this model can provide temperature measurement for further temperature compensation or temperature monitoring.

This model has its 316L stainless steel wetted parts fully welded, which eliminates appearance of any O-ring seal inside the inner cavity. As a result this transducer is suitable for measuring pressures of bio gas, natural gas, diesel, and gasoline.

To meet the need of precise metering applications, the 110S pressure transducer is manufactured with its accuracy presented in the terms either 0.2%rdg or 0.1%fs. The measuring range of the 110S is designed from 0~2 bar through 0~80 bar.

In addition to its standard mechanical interface with G1/4 male and M12x1.5 male threads, the process connection of the 110S can be also designed to customized geometry according to specific requirement of application. The electrical interface of the 110S is made with either silicon cable or PUR cable of 4-core conductor for both mV/V output and voltage excitation of Wheatstone bridge circuit.

Designed with its pressure reference of either absolute or gauge, the model 110S pressure transducer finds its market mostly in gas metering industry.



Features

- fully welded structure
- for precision measurement
- accuracy: up to 0.2%rdg or 0.1%fs
- integrated temperature sensor
- measuring ranges: 2bar, ..., 80bar
- proof pressure: 300%fs
- pressure references: absolute, gauge

Applications

- gas metering industry
- hydraulics and pneumatics
- compressor and pump systems
- liquid level measurement

BCM SENSOR TECHNOLOGIES BVBA

Model 110S Precision Pressure Transducers with Integrated Temperature Sensor



Dimensions

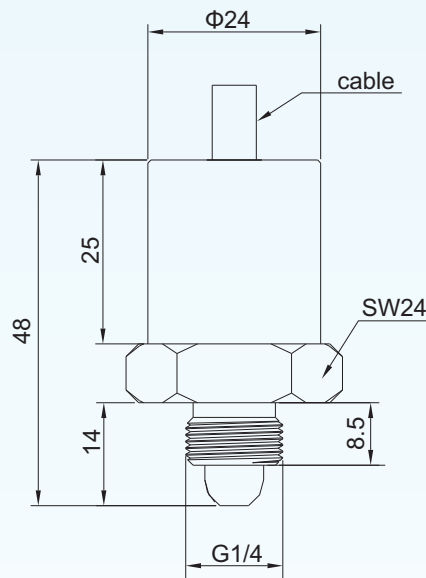
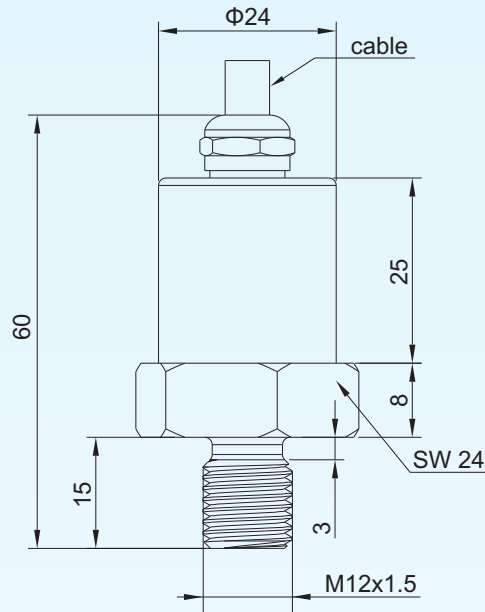

- Notes: - All dimensions are in mm.
- Other thread types are available on request.
- For customized dimensions, consult BCM.

BCM SENSOR TECHNOLOGIES BVBA

Model 110S Precision Pressure Transducers with Integrated Temperature Sensor



Technical Data

Parameters	Units	Specifications	Notes
pressure medium		gases or dilute fluids	1
measuring ranges	bar	0~2, ~5, ~10, ~20, ~30, ~60, ~80	2
pressure references		absolute, gauge	
proof pressure	%fs	300	3, 4
burst pressure	%fs	400	5
output sensitivity	mV/V	≥ 10	6
excitation	Vdc	1.5~5	
zero offset	mV/V	≤ ±0.8	7
accuracy	%rdg	±0.2, ±0.3 (standard)	8
	%fs	±0.1, ±0.2 (standard)	8
long-term stability	%fs/year	≤ ±0.2	
input resistance	kΩ	8±5	
output resistance	kΩ	4±2	
insulation resistance	MΩ	500 @100Vdc	
compensated temperature range	°C	-30 ~ +75	
operating temperature range	°C	-40 ~ +125	
storage temperature range	°C	-40 ~ +125	
temperature coefficient of zero offset	%fso/°C	≤ ±0.02	9
temperature coefficient of span	%fso/°C	≤ ±0.03	9
temperature sensor sensitivity	mV/°C	2	
temperature measuring range	°C	-30 ~ +75	
life time	cycles	10 ⁸	
response time	ms	≤ 1	10
process sealing		metal surface contact seal	
mechanical interface		M12x1.5 male (standard), G1/4 male	
electrical interface		Φ6mm, 5-core shielded, silicone rubber, 1m (standard)	11
		Φ6mm, 5-core shielded, PUR, 1m	11
		Φ5mm, 5-core shielded, PVC, 1m	11
pressure diaphragm		316L SS	
wetted parts material		316L SS	
net weight	gram	~130	

General conditions for measurements: media temp. = 25°C ±1°C, ambient temp. = 25°C ±1°C, humidity = 50%RH ±10%RH,
barometric pressure: 86~106 kPa, vibration = 0.1 g (1m/s/s) max.

- Notes:
1. The pressure medium should be compatible with wetted parts material and pressure diaphragm.
 2. For customized pressure ranges, consult BCM.
 3. "fs" refers to full scale pressure or rated pressure.
 4. Proof pressure: If an overload pressure applied onto the unit is higher than its proof pressure, the unit can not keep its specifications after the overload pressure is removed.
 5. Burst pressure: If an overload pressure applied onto the unit is higher than the burst pressure, it may cause mechanical damage to the unit.
 6. Other options are available on request, e.g., 4~20mA, 0.5~4.5V ratiometric, I²C.

BCM SENSOR TECHNOLOGIES BVBA

Model 110S Precision Pressure Transducers with Integrated Temperature Sensor



- Notes:
7. Measured at 2.5Vdc excitation.
 8. Accuracy (i.e., total error) = $\sqrt{\text{non-linearity}^2 + \text{hysteresis}^2 + \text{repeatability}^2}$.
 9. Calculated as a rate of output change between 25°C and 70°C, and normalized by the output at 25°C, when the sensor is not temperature compensated.
 10. Response time for a 0bar to fs step change, 10% to 90% rise time.
 11. The specification of the electrical interface illustrates diameter of cable, number of cores, material of cable jacket, and cable length.

The listed specifications and dimensions are subject to change without prior notice.

Ordering Information

position (pos.) 1: model						
110S						
pos. 2: pressure range and reference						
2bar G, A		60bar G, A		G: gauge pressure		
5bar G, A		80bar G, A		A: absolute pressure		
10bar G, A						
20bar G, A						
30bar G, A						
pos. 3: output sensitivity						
10mV/V						
pos. 4: accuracy						
0.2%rdg		0.3%rdg		0.1%fs		0.2%fs
pos. 5: mechanical interface						
M12x1.5(male)			G1/4(male)			
pos. 6: electrical interface						
diameter of cable/number of cores/cable jacket/cable length						
6/5/silicone rubber/1						
6/5/PUR/1						
6/5/PVC/1						
pos. 7: customized specifications						
“(*)” is necessary only if any customized parameter is required, otherwise it is neglectable.						
pos.1	pos. 2	pos. 3	pos. 4	pos. 5	pos. 6	pos. 7

Examples of Ordering Code

- standard transmitter:
110S-10barG-10mV/V-0.3%rdg-M12x1.5(male)-6/5/silicone rubber/1
 - customized transmitter:
110S-15barG-0.5/4.5V-0.2%fs-M12x1.5(male)-5/4/PVC/1-(*)
- (*): Customized pressure range = 0~15 barG.
Customized output = 0.5~4.5V.
Electrical interface = Φ 5mm, 4-core shielded, PVC, 1m.



BCM SENSOR TECHNOLOGIES BVBA