

# INSTRUCTION MANUAL

## YPA Pneumatic Aseptic ON-OFF Valve with Metallic Bellow

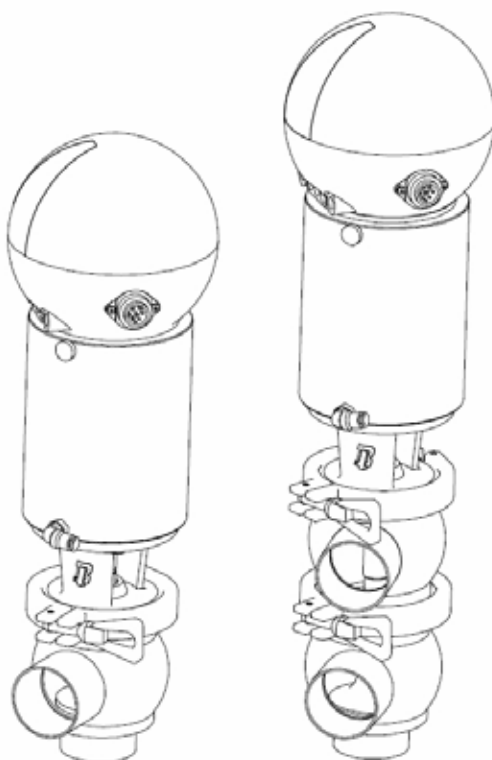

**B**ARDIANI  
VALVOLE

# Table of Contents

---

1. Safety signs .....	3
2. General safety precautions .....	3
3. Receiving/Unpacking/Storage.....	4
4. Installation .....	5
5. Operation .....	7
6. Troubleshooting .....	8
7. Cleaning.....	9
8. General maintenance.....	10
9. Planned maintenance .....	11
10. Spare parts ordering .....	12
11. Disassembly of valve type YPA.....	13
Drawings YPA .....	14
12. Assembly of valve type YPA.....	15
13. Disassembly of valve type YPA divert.....	16
Drawings YPA divert.....	17
14. Assembly of valve type YPA divert.....	18
15. Parts list .....	19
16. Technical data .....	20
Warranty.....	21
Disclaimer .....	21

---

## Foreword

**This instruction manual is an integral part of the valve delivery.**

- **To use the Atex valve model is obligatory to consult the appropriate manual.**
- **Always read it carefully before using the valve.**
- **Always keep it for future reference.**

All rights are reserved. It is forbidden to reproduce or transit any part of the instruction manual by any means, either electronic or mechanical, including photo copies, recording or any other memorisation or retrieval system for purposes other than the exclusively personal use by the purchaser – without prior written permission by the manufacturer.

This instruction manual is expressly intended for use by technicians. Therefore, some information which can easily be inferred by reading the text and examining the illustrations and drawings has not been further specified. The publisher is not responsible for any consequences of incorrect operations by the user.

The data and information in this instruction manual are subject to modifications or updates without any further notice or obligations on the part of the manufacturer.

## 1. Safety/Caution Signs



General WARNING sign, which indicates that special instructions MUST be followed to avoid serious personal injuries.



General CAUTION sign, which indicates that special instructions MUST be followed to avoid damage of equipment and environment.

### **NOTE!**

Indicates IMPORTANT information, which improves the understanding of the instructions.

## 2. General Safety Precautions



ALWAYS read the technical data before installation, operation and maintenance.

ALWAYS use authorised personal to install, operate and service the valve. The personal should know the valve and the instruction manual thoroughly.

ONLY use the valve for the designed purpose.

ALWAYS handle heavy valves carefully and use lifting tools where necessary.

ALWAYS pay attention to possible loose valve parts when unpacking the delivery.

ALWAYS connect air supply carefully and disconnect after use.

ALWAYS connect electrical supply carefully and disconnect after use.

NEVER touch moving valve parts.

NEVER touch a hot valve.

ALWAYS handle cleaning agents carefully.

NEVER remove a valve from piping or disassemble it when the valve or piping are pressurised.

**We cannot be held responsible for incorrect installation,  
operation and maintenance!**

# 3.Receiving/Unpacking/Storage

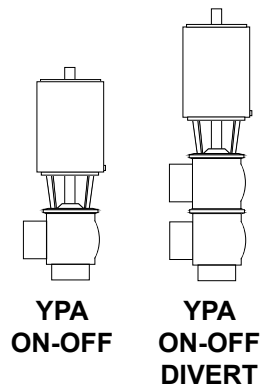
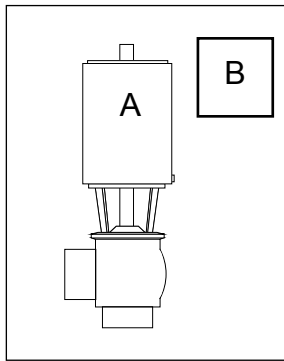

**ATTENTION !**

**1. UNPACK AND CHECK VALVE DELIVERY:**

- A. Complete valve
- B. Instruction manual

**2. IDENTIFY VALVE TYPE SUPPLIED:**

YPA: Pneumatic ON-OFF

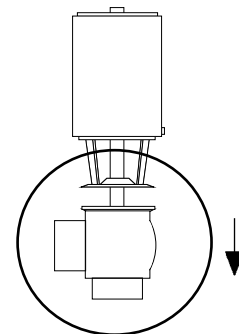
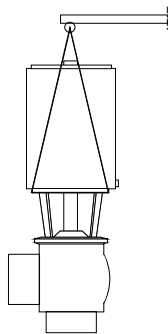

**3. LIFTING OF HEAVY VALVE:**

- Use lifting tool, if necessary.
- Fix valve to lifting tool.

**4. HANDLING OF LOOSE VALVE PARTS:**

- Avoid falling loose valve parts.
- Assemble and tighten loose parts.

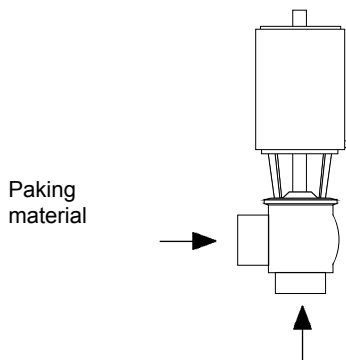

- Opening
- Air connections
- Electrical connections (for Giotto-Top®)

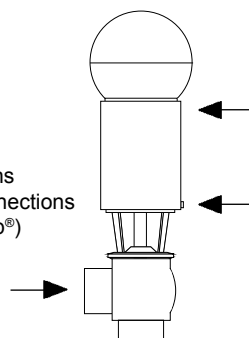

Safe valve protection!

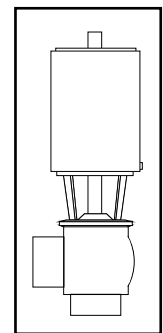

**5. PACKING MATERIAL:**

- Inspect internal of valve.
- Remove material and dispose of according to current directives.

**6. INSPECTION/CLAIM:**

- Inspect valve connections.
- Document /verify damage, missing or wrong parts.
- Use current claim procedure if necessary.

**7. STORAGE/PROTECTION:**

- Avoid dust, humidity, wet areas, heat and similar.
- Avoid vibration.
- Min.: - 10 °C
- Max.: + 50 °C

## 4. Installation

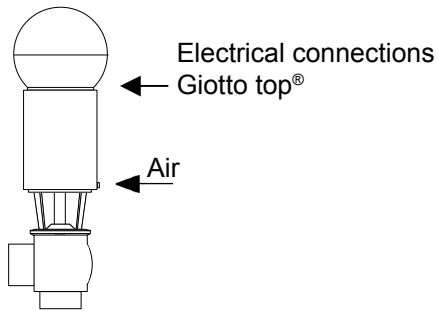

### 1. CONNECTION OF AIR AND EL SUPPLY:

- Use authorised personnel to install/connect the valve.
- Ensure correct air pressure and quality (see page 20).
- Ensure correct electrical supply for Giotto-Top® (see Giotto-Top® instruction manual).

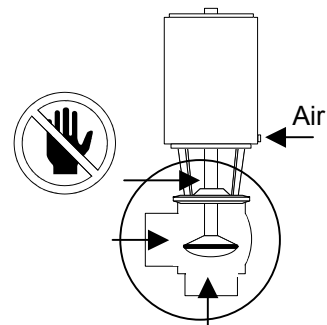
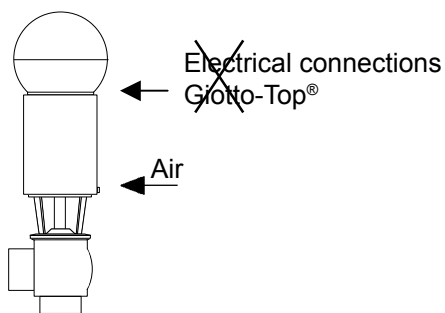

### 2. DISCONNECT SUPPLIES AFTER USE:

- Disconnect air supply.
- Disconnect electrical supply (for Giotto-Top®).



### 3. MOVING VALVE PARTS:

- Never stick fingers into valve ports.

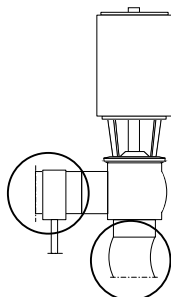

### 4. AVOID VALVE OVERLOADING AND COMPENSATE FOR:

- Vibration
- Thermal expansion

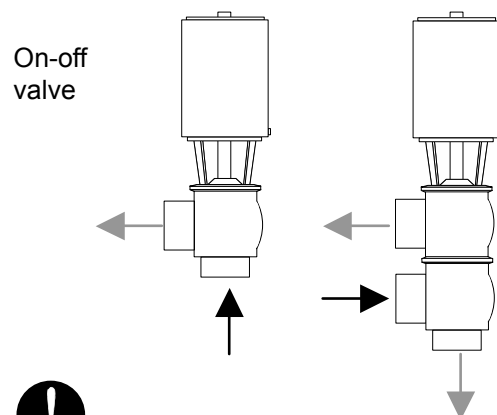

### 5. CORRECT FLOW DIRECTION:

- If possible, have flow against valve closing direction to avoid or minimise water hammer.

## 4. Installation

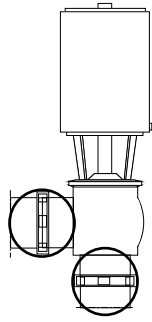

### 6. VALVE CONNECTIONS/UNIONS:

- Ensure tight connections between valve and piping.
- Remember gaskets and fit correctly.
- Tighten unions firmly and carefully.

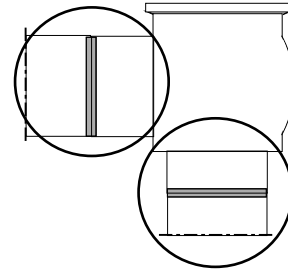

### 7. WELDING VALVE BODY INTO PIPING:

- Remove inner valve parts.
- Weld body carefully into piping.
- Assemble valve.
- See assembly instructions.

### YPA (with Giotto-Top®)

Dimension Valve	A (mm)
DN25--40	300
DN50	320
DN65	340
DN80	360
DN100	380

### 8. INSTALLING VALVE INTO PIPING:

Ensure sufficient clearance for valve disassembly.

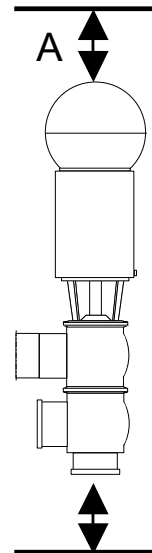

## 5. Operation

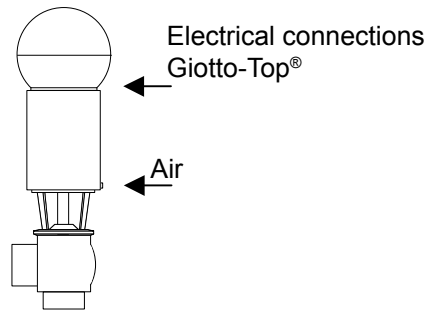

### 1. SUPPLYING AIR AND EL TO VALVE:

- Use authorised personnel to operate the valve.
- Ensure correct air pressure and quality (see page 20).
- Ensure correct electrical supply for Giotto-Top® (see Giotto-Top® instruction manual).

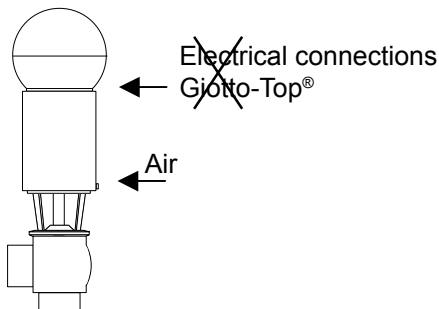

### 2. DISCONNECT SUPPLIES AFTER USE:

- Disconnect air supply.
- Disconnect electrical supply for Giotto-Top® (see Giotto-Top® instruction manual).

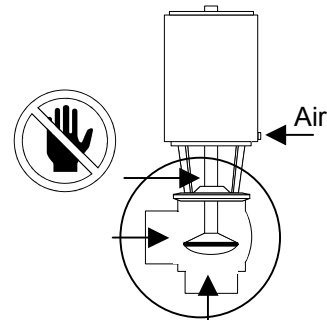

### 3. MOVING VALVE PARTS:

- Never stick fingers into valve ports.
- Never touch moving valve shutter/stem.

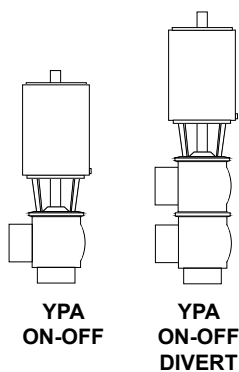

### 4. ONLY USE VALVE FOR DESIGNED PURPOSE:

YPA: Pneumatic ON-OFF

BURNING RISK!!

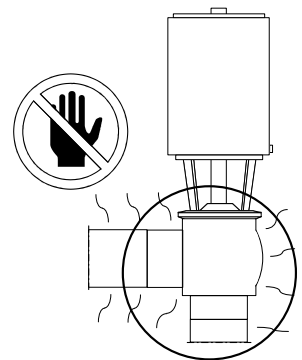

### 5. HOT VALVE/PIPING:

- Never touch hot valve or piping, if possible.
- Alternatively use protective gloves.

## 5. Operation

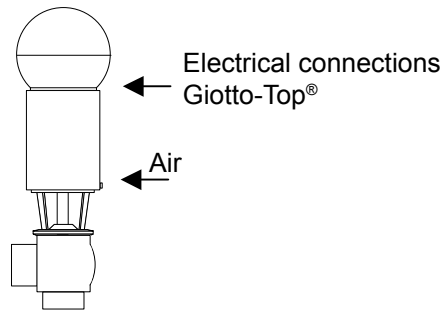

### 6. PRE-USE CHECK VALVE BEFORE OPERATION:

- Supply air to the valve.
- Supply el to the valve (with Giotto top®).
- Open and close the valve several times.
- Check that the valve functions operate correctly and smoothly.

## 6. Troubleshooting



### 1. TROUBLESHOOTING VALVE:

Always study operation and maintenance instructions carefully before troubleshooting.



### 2. REPLACING WORN VALVE PARTS:

- See page 12 for spare parts ordering.

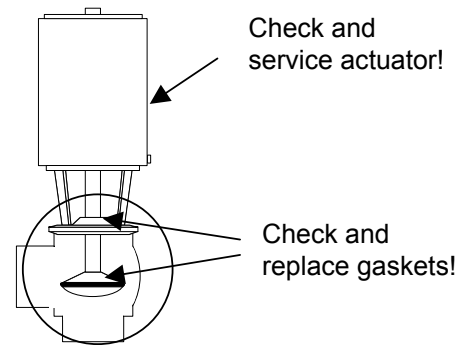

PROBLEM	POSSIBLE CAUSE	POSSIBLE REMEDY
External leakage	Worn out gasket	Replace gasket
Internal leakage with closed valve, caused by normal wear		
Internal leakage	Too high pressure	Verify operation conditions
	Too high temperature	Replace with gasket of different elastomer type
	Metal bellows defect	Replace the bellow
Internal leakage with closed valve occurring earlier than normal wear	Aggressive fluids	Modify operation conditions
	Too many active control	
Difficult opening and closing	Incorrect elastomer type of gaskets	Replace with gasket of different elastomer type
	Dirt/foreign materials between valve seat and bellows	Clean the valve housing and the bellows
	Incorrect positioning of actuator	Assemble actuator correctly
	Incorrect operation of actuator	Change from normally open (NO) to normally closed (NC) or vice versa
	Dirt in actuator	Check and service actuator
	Incorrect positioning of valve body	Disassemble and reposition valve body



## 7. Cleaning

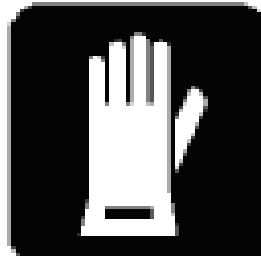

### 1. CLEANING VALVE WITH CLEANING AGENTS:

- Use authorised personnel to clean the valve.
- Observe concentrations of cleaning agents.
- Follow instructions of cleaning agent suppliers.
- Always use protective goggles and gloves.

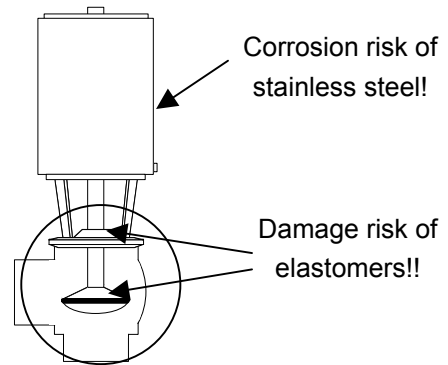
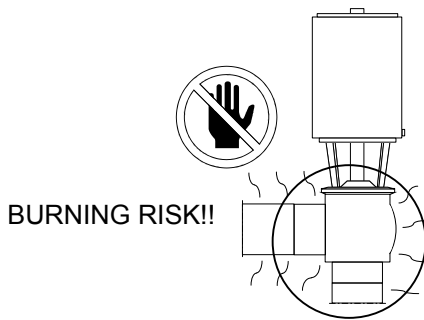

### 2. HOT VALVE/PIPING:

- Never touch hot valve or piping, if possible.
- Alternatively use protective gloves.

### 3. HANDLING OF CLEANING AGENTS:

- Dose cleaning agents regularly to avoid excessive concentration.
- Always rinse carefully with clean water after cleaning.
- Check compatibility of valve materials.
- Always dispose of cleaning agents according to current directives

Example of suggested CIP		
Step	Temperature °C	Cip product
First rinsing	Atmosphere	Water without chlorine or chlorids
Washing	70°	Soda (NaOH) at 1%
Intermediate washing	Atmosphere	Water without chlorine or chlorids
Washing	70°	Nitric acid (HNO3) at 0,5%
Final rinsing	Atmosphere	Water without chlorine or chlorids

Recommended claning speed = 2 m/s

## 8. General Maintenance

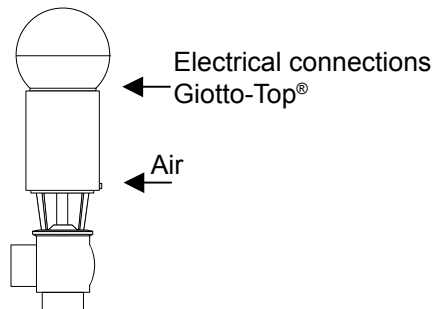

### 1. SUPPLYING AIR AND EL TO VALVE:

- Use authorised personnel to service the valve.
- Ensure correct air electrical supply for Giotto-Top® (see Giotto-Top® instruction manual).
- Ensure correct air pressure and quality (see page 20).
- Always dispose of cleaning agents according to current directives.

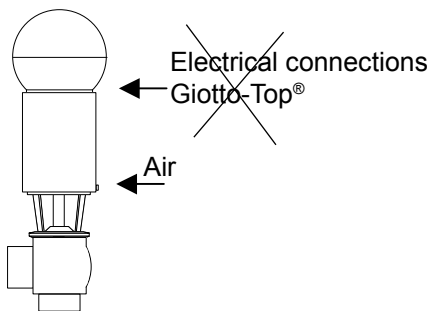

### 2. DISCONNECT SUPPLIES AFTER USE:

- Disconnect air supply.
- Disconnect electrical supply for Giotto-Top®
- Ensure correct air pressure and quality (see page 20).

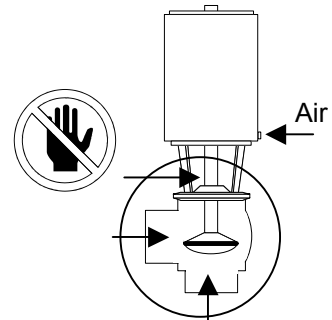

### 3. MOVING VALVE PARTS:

- Never stick fingers into valve ports.
- Never touch moving valve shutter/stem.

Atmospheric  
pressure  
required!

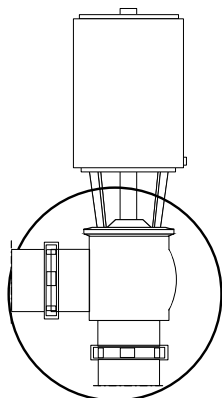

### 4. PRESSURISED VALVE/PIPING:

Always release fluid pressure from valve and piping before disassembling the valve.

BURNING RISK!!

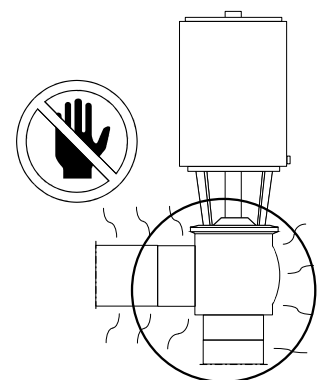

### 5. HOT VALVE/PIPING:

- Never touch hot valve or piping, if possible.
- Alternatively use protective gloves.

## 8. General Maintenance

Wash and clean  
thoroughly

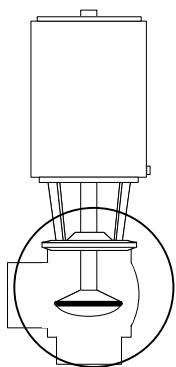

### 6. CLEANING OF DEPOSITS:

- Wash and clean all valve parts thoroughly before disassembly and assembly!
- Pay attention to possible deposits of cleaning agents and other aggressive fluids!
- Always use protective goggles and gloves, if necessary.



### 7. REPLACING WORN VALVE PARTS:

- Always use original spare parts.
- See page 12 for spare parts ordering.

## 9. Planned Maintenance

Planned maintenance	Valve gaskets	Actuator gaskets
Preventive	Replace after 12 months	Replace after 24 months
In case of leakage	Replace at the end of the day	Replace in case of leakage
Periodical	Check for correct operation and absence of leakage	Check for correct operation and absence of leakage
	Record all actions taken	Record all actions taken

### ATTENTION:

The actual maintenance intervals can only be determined by the plant user, since they depend on the operating conditions, for instance.

- daily period of operation
- switching frequency
- type and temperature of the product
- type and temperature of the cleaning solution
- ambient conditions

# 10. Spare Parts Ordering

**NOTE!**

Please copy this page, fill it out and fax it to below address.

À :  
 BARDIANI VALVOLE S.P.A. – Ufficio Ricambi  
 Fax: +3905253408

From:			
Valve type:			
Serial number:			
Month/Year of purchase:			
Shipping instructions:			
Quantity:		Position no.:	
Description:			
Quantity:		Position no.:	
Description:			
Quantity:		Position no.:	
Description:			
Quantity:		Position no.:	
Description:			
Quantity:		Position no.:	
Description:			
Quantity:		Position no.:	
Description:			

# 11. Disassembly of YPA

**1.** To fix the washer (7) through fitting (24) with 2 screws M6x10 and supply air to fitting (24).

**2.** Remove clamp (33) and body (1).

**3.** Release air pressure from fitting (24).

**Counterhold!**

**4.** Unscrew shutter (2) from cylinder pivot (9). Counterhold the pivot with an Allen wrench.

**5.** Remove shutter ring (14).

**6. PTFE SHUTTER:** Unscrew shutter nut (28) and remove shutter ring (14).

**7.** Remove screws (34) and assembly (35) into the cylinder (9).

**8.** Remove screws (8) and washer (7) and seal ring (6, 19).

**9.** Remove seal ring (138, 156, 57) and bushing (120).

# 11. Disassembly of YPA

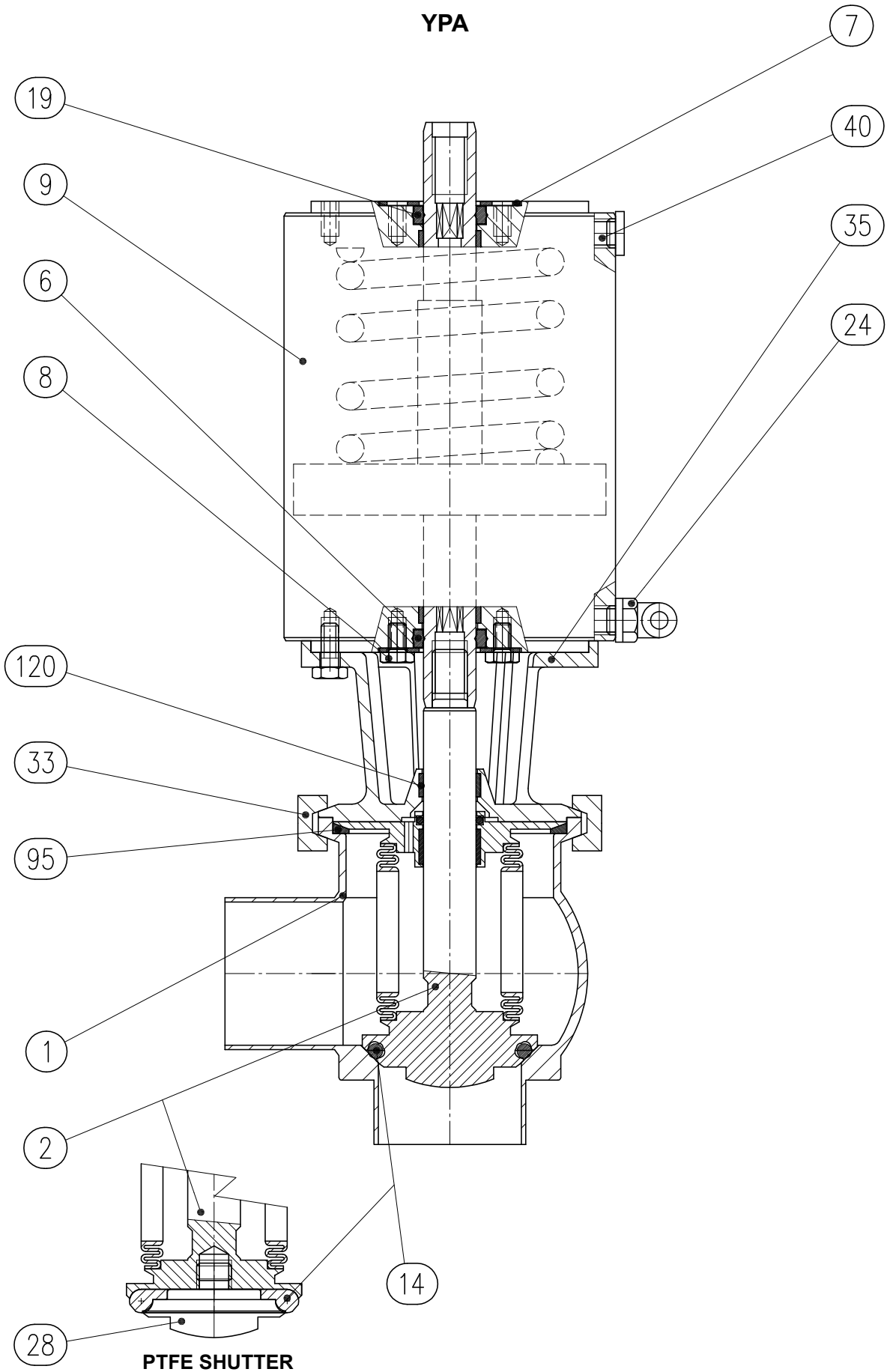

# 12. Assembly of YPA

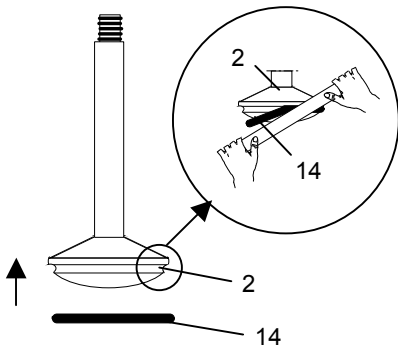

**1.** Pre-heat shutter ring (14) to approx. 80°C to make it softer and insert it in shutter slot (2). Insert the ring in a crosswise manner using a plastic cylindrical tool.

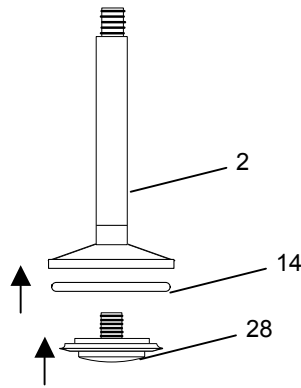

**2. PTFE SHUTTER:** Fit shutter ring (14) on shutter (2) and fit shutter nut (28).

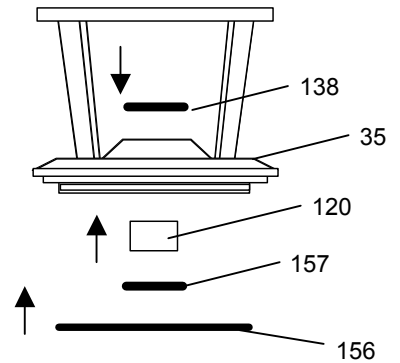

**3.** Insert seal rings (156, 157, 138) and bushing (120) into assembly (35).

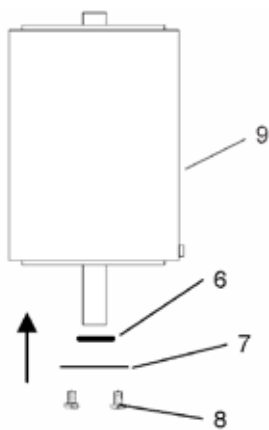

**4.** Insert seal ring (6) into cylinder (9) and fit washer (7) and screws (8).

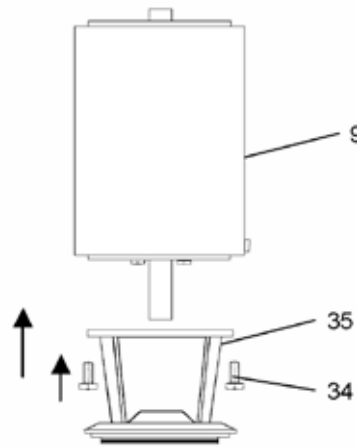

**5.** Fit assembly (35) to cylinder (9) with screws (34).

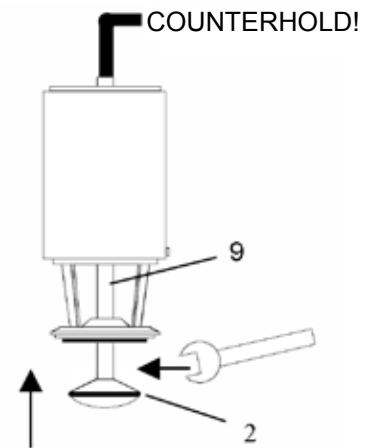

**6.** Screw shutter (2) into cylinder pivot (9). Counterhold the pivot with an allen wrench.

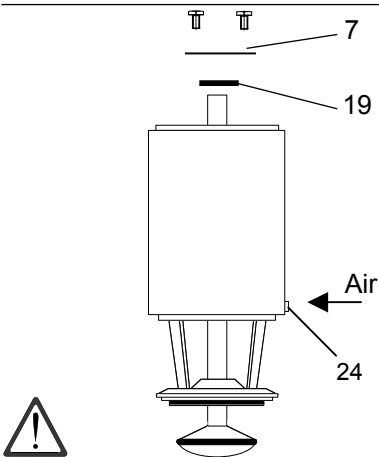

**7.** Insert seal ring (19) and washer (7) with 2 screw M6x10. Supply air to fitting (24).

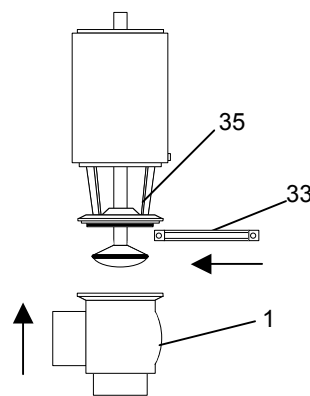

**8.** Assemble body (1) and assembly (35) with clamp (33).

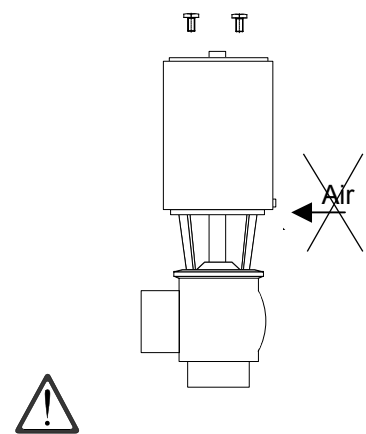

**9.** Release air pressure to air fitting (24) and remove the screw M6x10 to allow assembly of the Giotto-Top®.

# 13. Disassembly of YPA divert

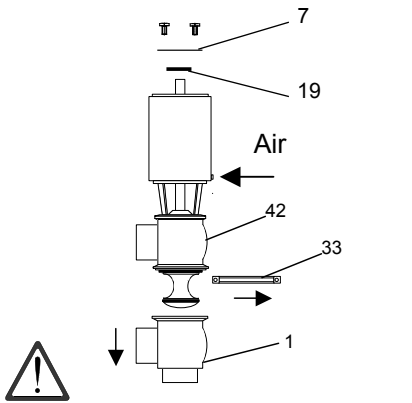

**1.** To fix the washer (7) through 2 screw M6x10 and supply air to fitting (24). Remove clamp (33) between lower body (1) and upper body (42). Remove lower body.

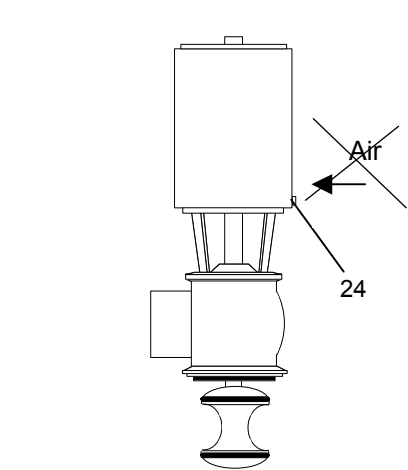

**2.** Release air pressure to air fitting (24).

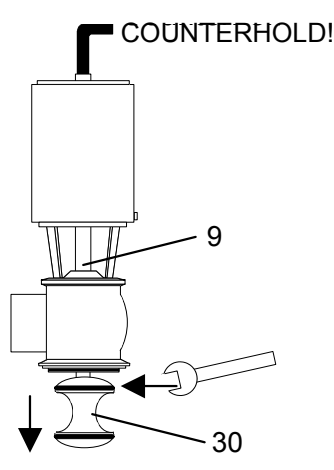

**3.** Unscrew shutter (30) from cylinder pivot (9). Counterhold the pivot with an allen wrench.

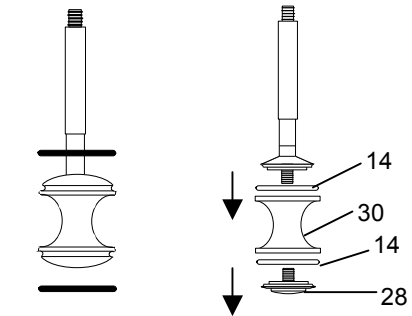

**4a. STANDARD SHUTTER:**  
Remove shutter rings (14).  
**4b. PTFE SHUTTER:**  
Remove shutter nut (28) and lower shutter ring (14). Remove shutter (30) and upper shutter ring (14).

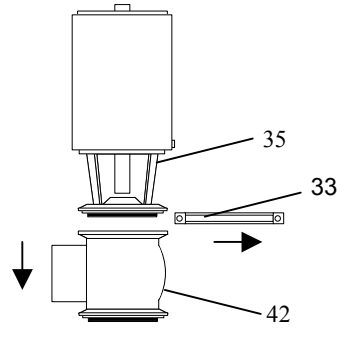

**5.** Remove clamp (33) and upper body (42) from assembly (35)

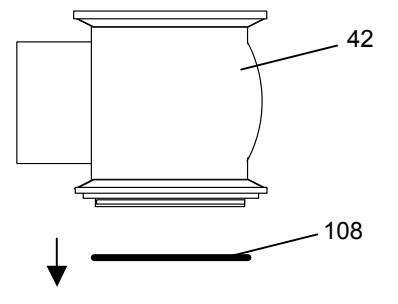

**6.** Remove seal ring (108) from upper body (42).

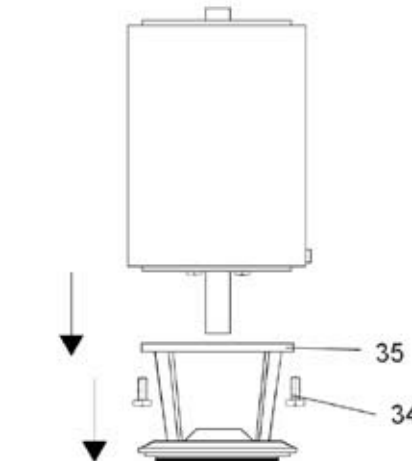

**7.** Remove screws (34) and assembly (35).

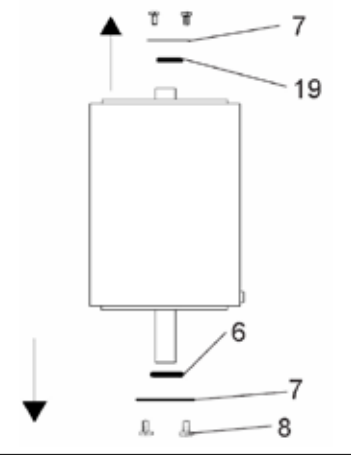

**8. VALVE SIZE DN25--100:**  
Remove screws (8), washer (7) and seal ring (6,19).

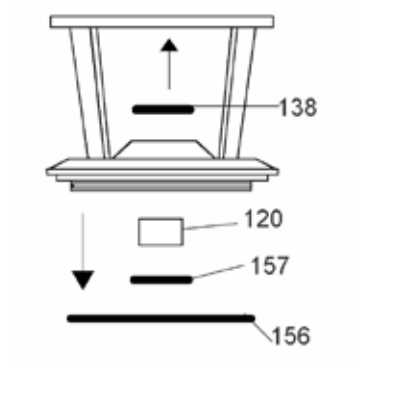

**9.** Remove seal rings (138,156, 157), bushing (120).



# 13. Disassembly of YPA divert

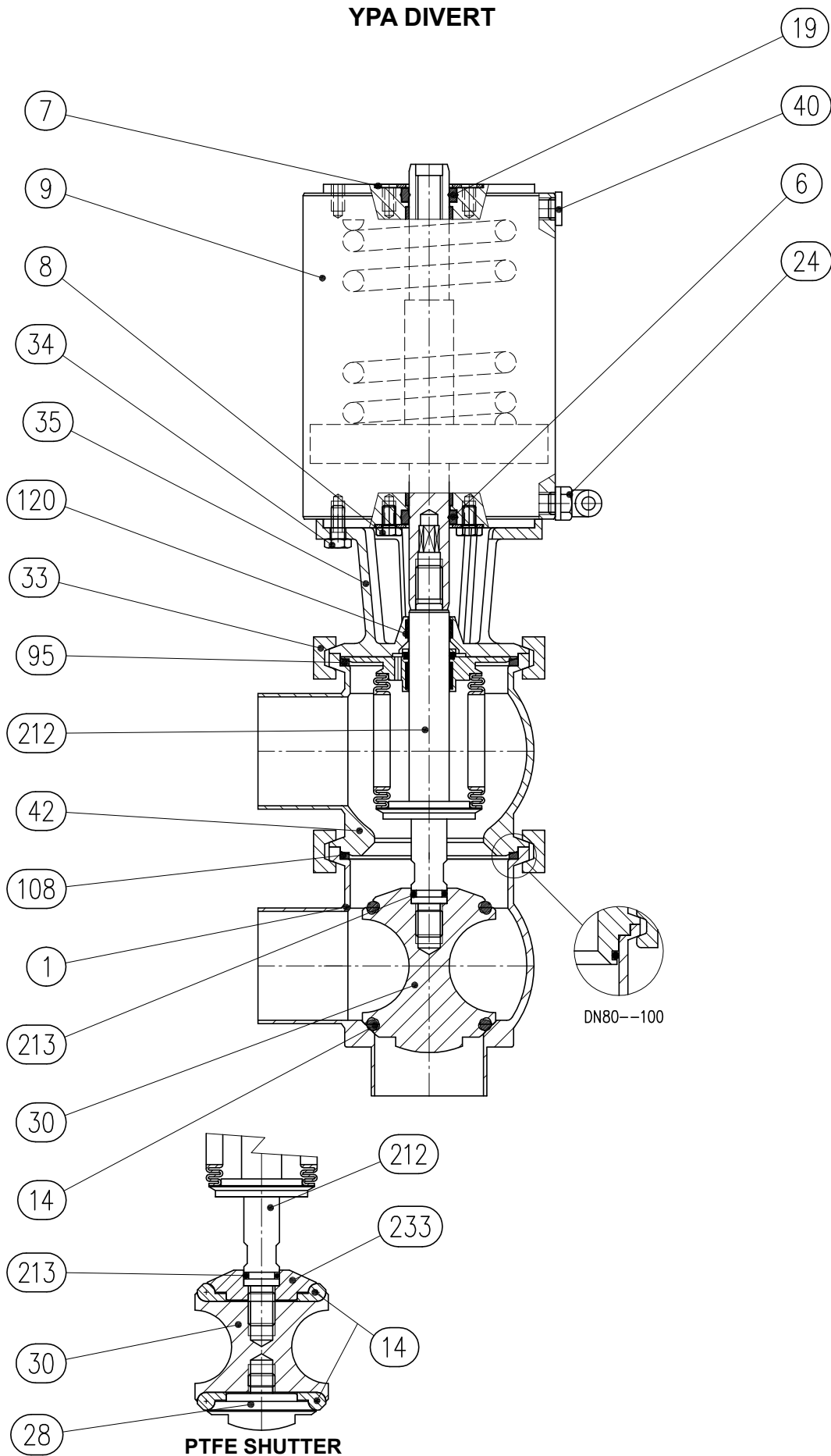

# 14. Assembly of YPA divert

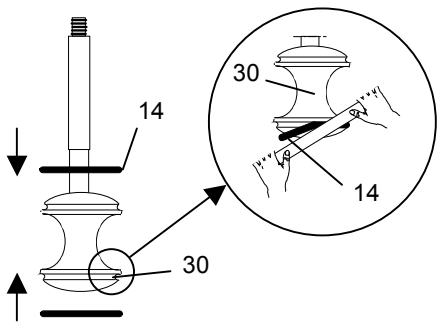

**1.** Pre-heat shutter ring (14) to approx. 80 °C to make it softer and insert it in shutter slot (30). Insert the ring in a crosswise manner using a plastic cylindrical tool.

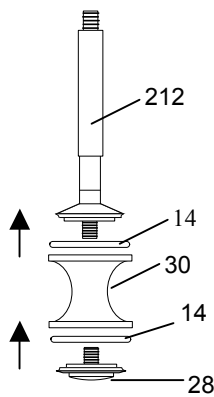

**2. PTFE SHUTTER:** Assembly shutter ring (14) and shutter (30) with the stem (212). Assembly shutter ring (14) and shutter nut (28).

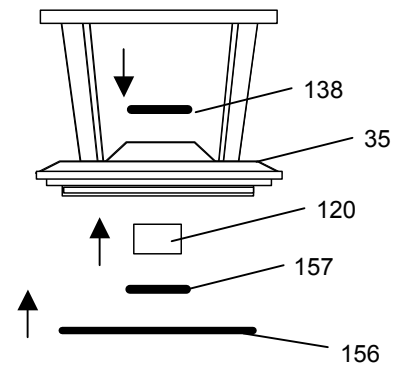

**3.** Insert seal rings (156, 157, 138) and bushing (120) into assembly (35).

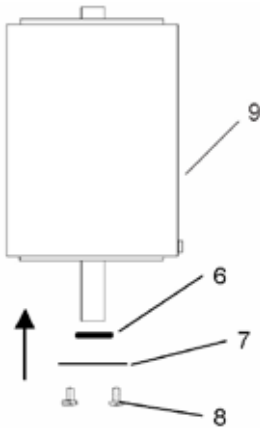

**4.** Insert seal ring (6) in the cylinder (9) and fit washer (7) and screws (8).

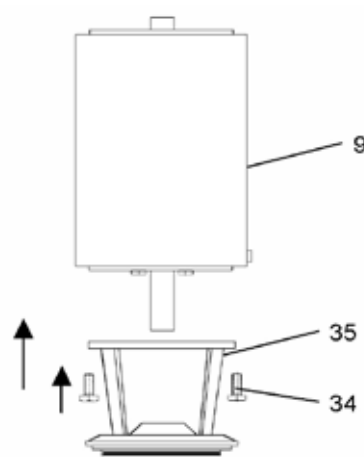

**5.** Fit assembly (35) and cylinder (9) with screws (34).

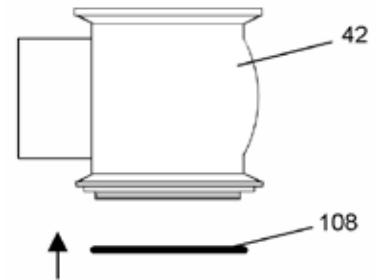

**6.** Insert seal ring (108) on upper body (42).

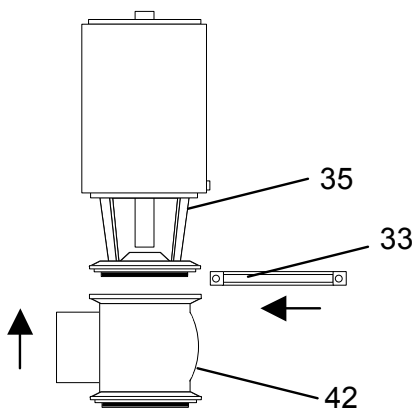

**7.** Fit upper body (42) and assembly (35) with clamp (33).

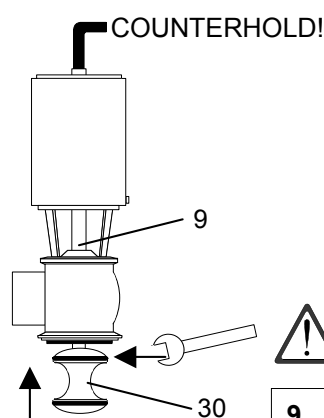

**8.** Screw double shutter (30) into cylinder pivot (9). Counterhold pivot with an allen wrench.

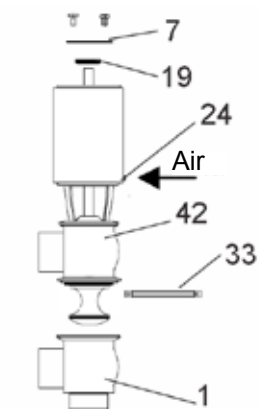

**9.** Insert seal ring (19) and fix washer (7) with 2 screws M6x10. Supply air to fitting (24) assemble lower body (1) and upper body (42) with clamp (33). Release air pressure.

## 21. Part List

Item	Description	Item	Description
1	Lower body		
2	Shutter		
4	Seal ring		
6	Seal ring		
7	Seal washer		
9	Cylinder		
14	Seal ring		
19	Seal ring		
24	Air fitting		
28	Shutter nut		
30	Double shutter		
33	Clamp		
34	Socket screw		
35	Assembly		
40	Plug		
95	Seal ring		
108	Seal ring		
120	Guide bushing		
212	Steam double shutter		
233	Piattello/Collar		

## 22. Technical Data

### Valve Specifications:

Max. working pressure :	6 bar (87 psi)
Min. working pressure :	0 bar (0 psi) vacuum is not recommended in aseptic applications.
Max. product temperature :	140 °C (284 °F)
Min. product temperature :	-10 °C (14 °F)
Material in contact with the product :	AISI 316L (1.4404)
Gasket in contact with the product (FDA homologation) :	EPDM, FKM, MVQ(silicon), HNBR, PTFE (other seals available upon request).
Finish on surfaces in contact with the product :	Ra 0.8 µm (other types of surface finish upon request).

### Pneumatic Actuator Specifications:

Connectors :	1/8" (BSP)
Air Pressure :	from 6 bar (87 psi) to 8 bar (116 psi)
Material :	AISI 304L (1.4307)
Gasket Material :	NBR
Power Supply (Giotto-Top®) :	See Giotto-Top® Instruction manual

### **PED Directive 97/23/EEC, with special reference to Annex III, Module A regarding internal production control as Conformity Assessment Procedure in force**

Valve sizes DN25 are not included in accordance with Article 3 paragraph 1.3:

Valves intended for gases, liquified gases, gases dissolved under pressure, vapours and those liquids whose vapour pressure at the maximum allowable temperature is greater than 0,5 bar above normal atmospheric pressure (1013 mbar) within the following limits

- For fluids in Group 1 with a DN greater than 25

## **DISCLAIMER**

This "Instruction, Use and Maintenance Manual" forms an integral part of the valve.

**Before proceeding with installation, use or maintenance of each type of valve it is compulsory to read and understand this manual.**

**Keep this manual for future reference.**

**When using valves which comply with ATEX Directive 94/9/EC (ATEX) it is compulsory to read the relative manual.**

This "Instruction, Use and Maintenance Manual" has been drawn up expressly for expert technical personnel. Consequently any information which can easily be deduced from reading the text and/or examining the illustrations and/or drawings provided herein shall not be the object of further explanation.

It being understood that the essential characteristics of the valve type described herein shall remain the same, the manufacturer reserves the right to amend and/or integrate and/or update the data and/or information relative to use of the valve provided in the "Instruction, Use and Maintenance Manual", at any time and without prior notice.

The latest, updated version of the "Instruction, Use and Maintenance Manual" is always available at [www.bardiani.com](http://www.bardiani.com).

The manufacturer shall not in any way be held liable for any consequences resulting from failure to observe all the prescriptions provided in the relative manual concerning installation, use, maintenance and care of the product.

All rights are reserved. It is forbidden, without due written authorization from the manufacturer, to copy totally and/or partially and /or transfer and/or record any part of this "Instruction, Use and Maintenance Manual" using any means and/or support, including IT and/or electronic and/or mechanical and/or paper form or any other means or system for recording and/or reusing the information contained herein for any purposes other than for the purchaser's personal use.

## **Warranty**

### **1. VALIDITY**

Bardiani Valvole S.p.A. guarantees its own products against any design and/or construction and/or material defects and/or faults for a period of 12 (twelve) months from the date of delivery.

Notification of any product defects and/or faults must be sent in writing to Bardiani Valvole S.p.A. within 8 (eight) days of coming to light, providing adequate documentation of the defect/fault encountered can be provided as evidence.

Any repairs made during the warranty period do not extend said period over the stipulated 12 (twelve) months which remains definite.

### **2. CONTENTS OF THE WARRANTY**

This warranty it to be intended as limited, at the discretion of Bardiani Valvole S.p.A., to the repair and/or replacement of the product and/or part of the product and/or its components which is/are found to be defective due to design and/or manufacturing and/or material faults.

In the event of repair and/or replacement of the product and/or any one of its parts and/or components, any returned item/s shall become the property of Bardiani Valvole S.p.A and the relative shipping costs shall be at the expense of Bardiani Valvole S.p.A.

Bardiani Valvole S.p.A., shall be under no obligation to compensate for any immaterial and/or indirect damages and shall in no way be held liable for consequential damages and/or losses, such as (by way of example only), damages due to loss of business, contracts, opportunities, time, production, profits, goodwill, image etc..

No retailer or distributor or dealer or agent or representative or employee or person appointed by Bardiani Valvole S.p.A. is authorized to make any amendments and/or integrations and/or extensions to this warranty.

### **3. EXCLUSIONS FROM THE WARRANTY**

All purchaser rights, as established and recognized by law being understood and unaffected, elastomers and electrical components are expressly excluded from this warranty.

This warranty does not cover design faults whenever a product is built by Bardiani Valvole S.p.A. based on designs and/or technical specifications provided by the purchaser.

This warranty also does not cover:

- faults and/or defects resulting from incorrect and/or unsuitable and/or improper transport,
- faults and/or defects resulting from installation of the product which fails to observe the indications provided in the "Instruction, Use and Maintenance Manual" or in any case caused by incorrect and/or unsuitable and/or improper installation,
- faults and/or defects resulting from use and/or maintenance operations and/or storage of the products which fail to observe the prescriptions provided in the "Instruction, Use and Maintenance Manual" or in any case which are incorrect and/or unsuitable and/or improper,
- faults and/or defects ascribable to normal wear and tear of the product and/or its parts and/or its components,
- faults and/or defects in the product and/or its parts and/or its components whenever interventions and/or repairs have been performed by persons not authorized by Bardiani Valvole S.p.A. and/or who are not suitably qualified,
- faults and/or defects in the product and/or its parts and/or its components ascribable to it being dropped and/or banged and/or dented and/or misuse and/or tampering and/or breakage and/or accidents caused by negligence and/or lack of care by the purchaser and in general for any causes not ascribable to design and/or manufacturing and/or material defects,
- faults and/or defects in the product and/or its parts and/or its components ascribable to negligence and/or carelessness and/or lack of care by the purchaser,
- faults and/or defects in the product and/or its parts and/or its components caused by other events outside the control of Bardiani Valvole S.p.A. or determined by force majeure **or mishap**.

## **Recommendations**

**1. All the information, indications, statements and technical details provided herein are based on test data which Bardiani Valvole S.p.A. holds to be reliable but which cannot be expected to cover every possible use of the product.**

**2. The illustrations and drawings provided are all indicative and are not binding, consequently they may not fully match the real appearance of the products.**

**3. Being as the conditions of product use and applications cannot be controlled by Bardiani Valvole S.p.A., the purchaser must ascertain suitability of the use he intends to make of the product beforehand and assume all risks and liabilities which may result from the same.**

**4. Customers are strongly advised to consult Bardiani Valvole S.p.A.'s technical-commercial collaborators to request any specific information concerning the technical characteristics of the products.**

**5. The information provided in this document refers to standard production Bardiani Valvole S.p.A. products and therefore cannot be considered a basic reference for products built to meet specific requirements.**