

Proportional 3/2 Throttle Cartridge, Size 5

$Q_{max} = 30 \text{ l/min}$, $p_{max} = 250 \text{ bar}$
 Sliding-spool design, direct acting
 Series MDR32GN...-5...

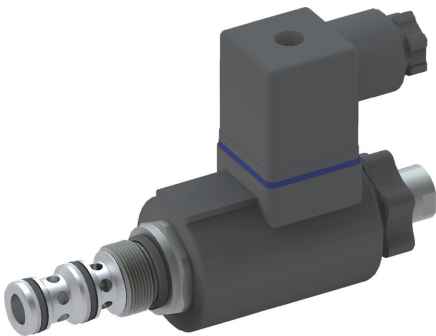

- De-energised closed 1 → 2
- Compact construction for cavity type AM – 3/4-16 UNF
- Very good reproducibility
- Reliable operation over the whole pressure and flow range (even with high pressure differentials)
- With optional manual flow setting
- All external parts zinc plated, chromited (CrVI-free)
- High pressure wet-armature solenoids
- The slip-on coil can be rotated, and it can be replaced without opening the hydraulic envelope
- Various plug-connector systems and voltages are available
- Can be fitted in a line-mounting body

1 Description

Series MDR32GN... direct acting proportional 3/2 throttle valves are size 5, high performance screw-in cartridges with a 3/4-16 UNF mounting thread. They are designed on the proven sliding-spool principle. The straightforward design delivers an outstanding price/performance ratio. In the initial position (de-energised), port 1 is closed and ports 2 → 3 are connected with the full flow rating. In control mode, the flow through the connection 1 → 2 is varied in proportionally to the control current. Three types are available: Type "A" - standard model, for general use with or without compensator. Type "Z" - special model, only approved for use with compensator (max. Δp 15 bar). Type "S600" - special model with optimised characteristic - $Q = f(I)$, also only

suitable for use with compensator. With this model, the connection 2 → 3 is only used for unloading (see Performance Graphs). These cartridges are particularly suitable for precise and controlled lifting and lowering movements, but they can also be used for reliable operation in mobile and industrial applications featuring large pressure differences. All external parts of the cartridge are zinc plated and chromited (CrVI-free) and are thus suitable for use in the harshest operating environments. The slip-on coils can be replaced without opening the hydraulic envelope and can be positioned at any angle through 360°. If you intend to manufacture your own cavities or are designing a line-mounting installation, please refer to the section "Related data sheets".

2 Symbol

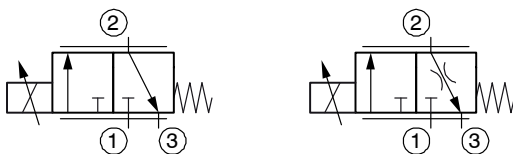

MDR32GNA5...
MDR32GNZ5...

MDR32GNA5...S600

3 Technical data

General characteristics	Description, value, unit
Designation	proportional 3/2 throttle cartridge
Design	sliding-spool design, direct acting
Mounting method	screw-in cartridge 3/4-16 UNF
Tightening torque	40 Nm ± 10 %

General characteristics	Description, value, unit
Size	nominal size 5, cavity type AM
Weight	0.40 kg
Mounting attitude	unrestricted (preferably vertical, coil down)
Ambient temperature range	-25 °C ... +50 °C

Hydraulic characteristics	Description, value, unit
Maximum operating pressure	250 bar
Maximum flow rate	30 l/min
Nominal flow rate 1 → 2	25 l/min at $\Delta p = 10$ bar
Leakage flow rate	< 150 cm ³ /min (with p_N 250 bar) with oil viscosity 33 mm ² /s (cSt)
Flow direction	see symbols
Hydraulic fluid	HL and HLP mineral oil to DIN 51 524; for other fluids, please consult BUCHER
Hydraulic fluid temperature range	-25 °C ... +70 °C
Viscosity range	15...380 mm ² /s (cSt), recommended 20...130 mm ² /s (cSt)
Minimum fluid cleanliness Cleanliness class to ISO 4406 : 1999	class 18/16/13

Electrical characteristics	Description, value, unit
Supply voltage	12 V DC, 24 V DC
Control current	12 V = 0...1400 mA, 24 V = 0...760 mA
Power consumption at max. control current	max. 19 W
Coil resistance R - cold value at 20 °C - max. warm value	12 V = 5.8 Ω / 24 V = 21 Ω 12 V = 8.6 Ω / 24 V = 32 Ω
Recommended PWM frequency (dither)	200 Hz
Hysteresis with PWM	2...4 % I_N
Reversal error with PWM	2...4 % I_N
Sensitivity with PWM	< 1 % I_N
Reproducibility with PWM	< 2 % p_N
Relative duty cycle	100 %
Protection class to EN 60 529	IP 65 / IP 67, see "Ordering code" (when connector plugs are properly fitted)
Electrical connection	3-pin square plug to ISO 4400 / DIN 43 650 (standard) for other connectors, see "Ordering code"

4 Performance graphs measured with oil viscosity 33 mm²/s (cSt)

For general use with / without compensator – type “A”

$\Delta p = f(Q)$ Pressure drop - Flow rate characteristic

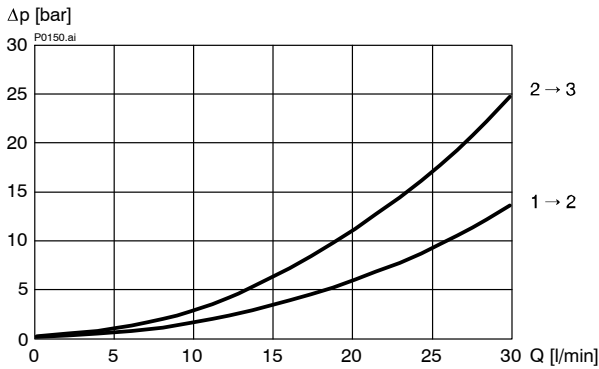

$Q = f(I; \Delta p)$ Flow rate adjustment characteristic

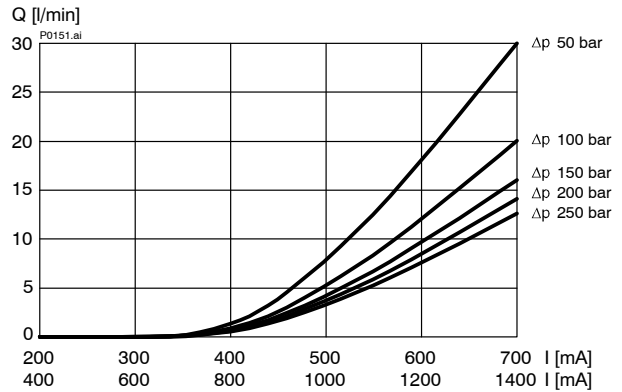

For use with compensator (max. $\Delta p = 15$ bar) – type “Z”

$\Delta p = f(Q)$ Pressure drop - Flow rate characteristic

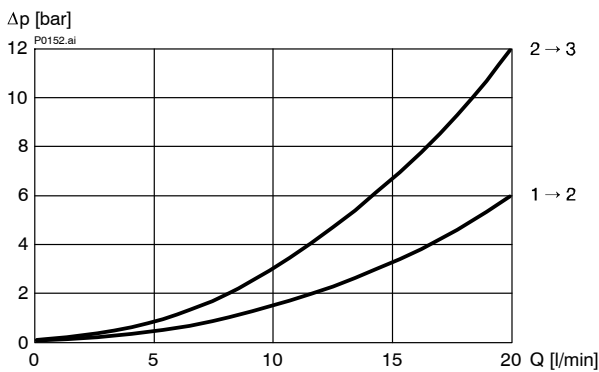

$Q = f(I; \Delta p)$ Flow rate adjustment characteristic

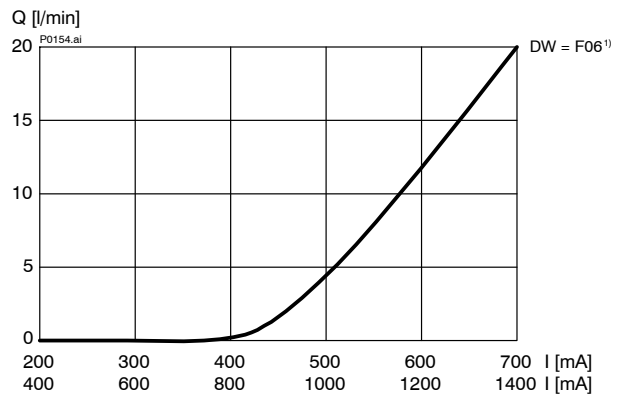

$Q = f(\Delta p; I)$ Flow rate adjustment characteristic

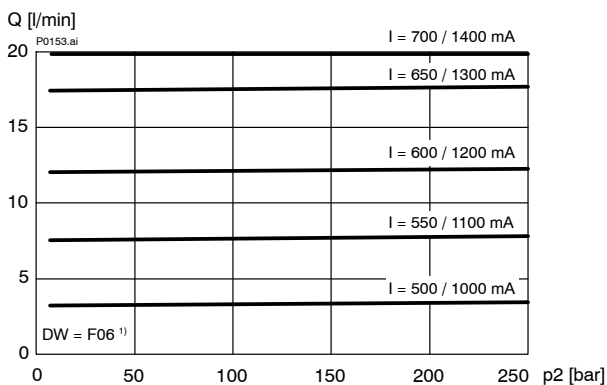

IMPORTANT!

1) Performance graphs measured with compensator model DWDPA-5D-10-F06-2

With optimised characteristic - $Q = f(I)$, type "S600" – with compensator (max. $\Delta p = 15$ bar)

$\Delta p = f(Q)$ Pressure drop - Flow rate characteristic

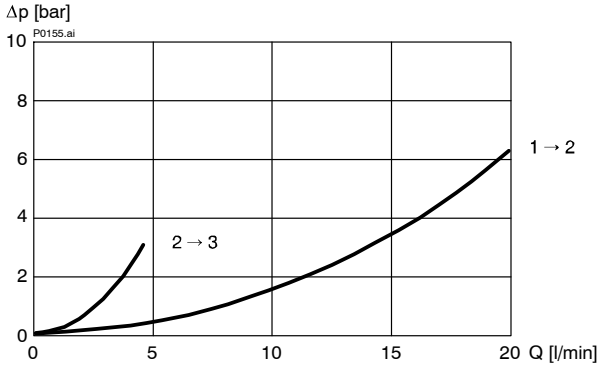

$Q = f(I; \Delta p)$ Flow rate adjustment characteristic

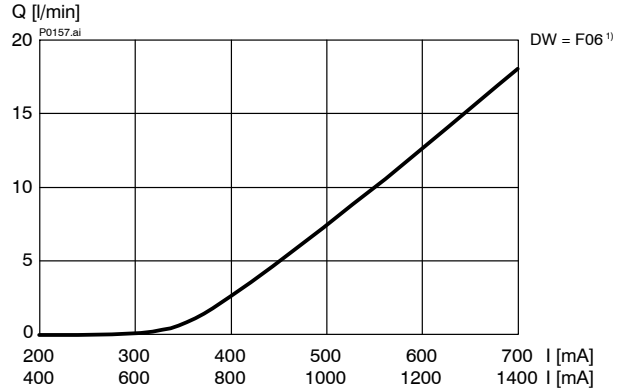

$Q = f(\Delta p; I)$ Flow rate adjustment characteristic

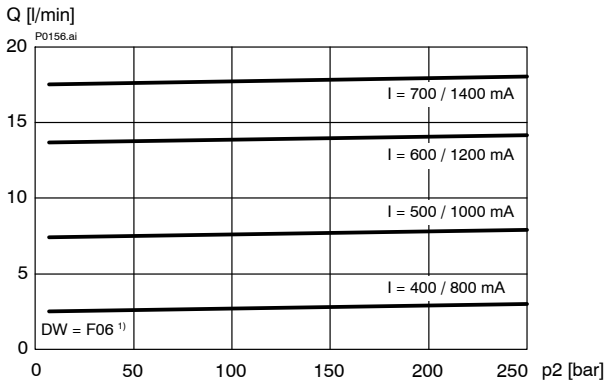

IMPORTANT!

1) Performance graphs measured with compensator model DWDPA-5D-10-F06-2

5 Installation information



IMPORTANT!

To achieve the proportional 3/2 throttle cartridge's maximum performance rating, fit the solenoid coil as shown (with the plug pins at the bottom). When fitting the cartridges, note the mounting attitude (preferably vertical, with coil down → automatic air bleed) and use the specified tightening torque. No adjustments are necessary, since the cartridges are set in the factory.



ATTENTION!

Only qualified personnel with mechanical skills may carry out any maintenance work. Generally, the only work that should ever be undertaken is to check, and possibly replace, the seals. When changing seals, oil or grease the new seals thoroughly before fitting them.

6 Dimensions & sectional view

Without manual flow setting – standard

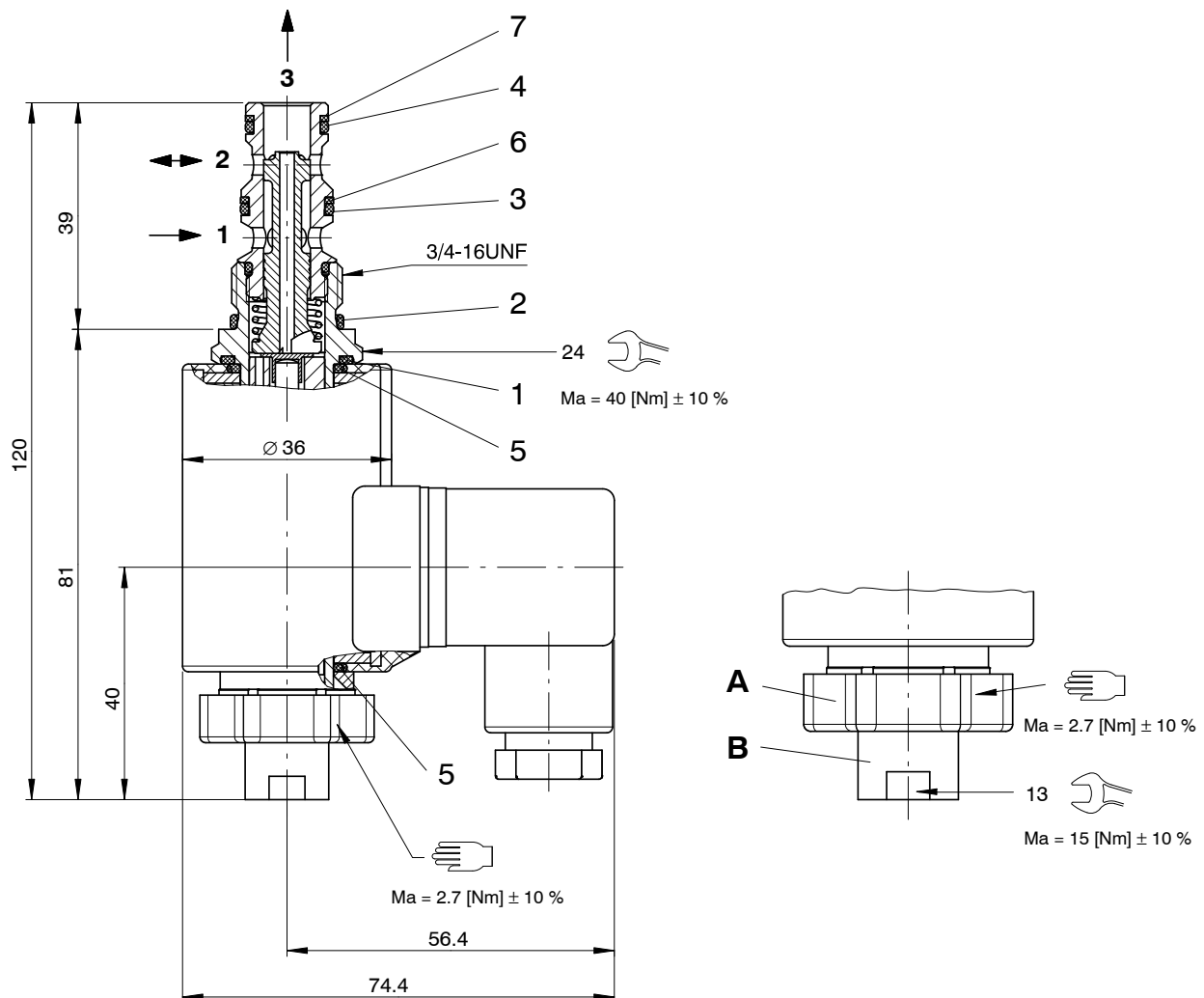

Seal kit NBR no. DS-247-N ²⁾

Item	Qty.	Description
1	1	O-ring $\varnothing 18,00 \times 2,00$ FKM
2	1	O-ring no. 017 $\varnothing 17,17 \times 1,78$ N90
3	1	O-ring no. 014 $\varnothing 12,42 \times 1,78$ N90
4	1	O-ring no. 013 $\varnothing 10,82 \times 1,78$ N90
5	2	O-ring $\varnothing 16,00 \times 2,00$ FKM
6	2	Backup ring $\varnothing 10,70 \times 1,45 \times 1,40$ FI0751
7	2	Backup ring $\varnothing 09,40 \times 1,45 \times 1,00$ FI0751



IMPORTANT!

²⁾ Seal kit with FKM (Viton) seals no. DS-247-V

Air-bleeding

If necessary, air can be purged from these proportional throttle cartridges by using the cap nut (Item B). The procedure is as follows:

- A Knurled nut
- B Cap nut

Steps:

1. Slacken and remove the knurled nut.
2. Slacken the cap nut approx. 1.5 turns.

Caution:

Slackening the cap nut allows oil to spray out!

3. Switch the proportional throttle cartridge ON/OFF several times until no more air bubbles escape.
4. Tighten the cap nut.
5. Refit the knurled nut and tighten it.

With manual flow setting – Option “E”

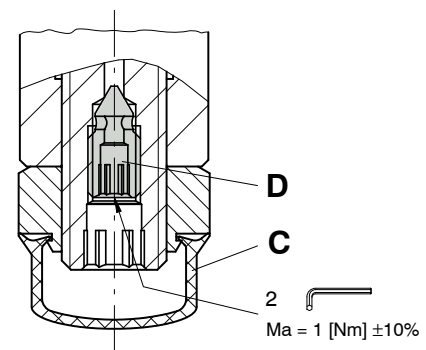
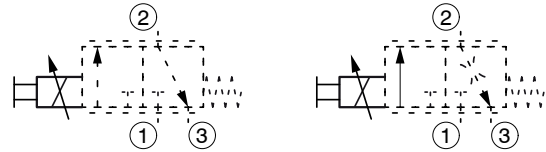
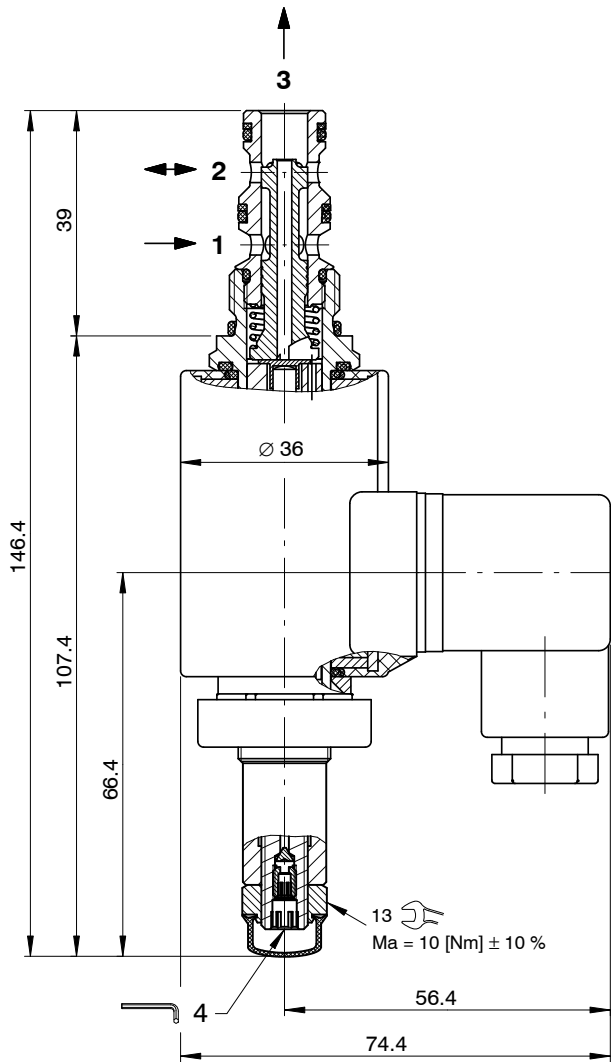

Integral air-bleeding

If necessary, air can be purged from these proportional throttle cartridges by using the integral air-bleed screw (Item D). The procedure is as follows:

- C Protective cap
- D Air-bleed screw

Steps:

1. Remove the protective cap.
2. Slacken the air-bleed screw approx. 2 turns.
3. Switch the proportional throttle cartridge ON/OFF several times until no more air bubbles escape.
4. Tighten the air-bleed screw.
5. Fit the protective cap.

7 Manual flow setting

Optionally, the proportional throttle cartridges can be supplied with an integral manual flow setting. If a proportional solenoid is faulty, for example, this manual flow setting enables the required flow rate to be set mechanically. This manual flow setting is not designed for adjusting the flow in a dynamic control mode.

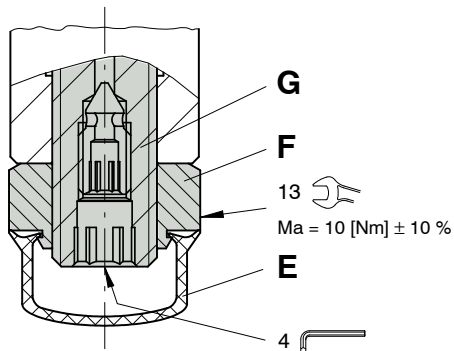

- E Protective cap
- F Lock nut (13 A/F)
- G Adjusting spindle for volume setting

Setting the flow rate manually

Steps:

1. Remove the protective cap.
2. Slacken the lock nut (13 A/F).
3. Screw in (turn to right) the adjusting spindle (4 A/F) until the required flow rate is set.
4. Tighten the lock nut (13 A/F).
5. Fit the protective cap.

Restoring the factory settings

Steps:

1. Solenoid de-energised.
2. Remove the protective cap.
3. Slacken the lock nut (13 A/F).
4. Unscrew the adjusting spindle (4 A/F) to its end-stop, then screw it in 2 turns.
5. Tighten the lock nut (13 A/F).
6. Fit the protective cap.

8 Application examples

Standard type "A"

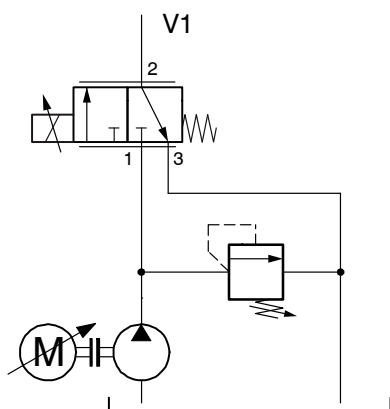

- Can be used without compensator (full Δp permissible)
- Full-flow connection 2 → 3
- Control is only available with connection 1 → 2

Special type “Z” – only to be used with compensator

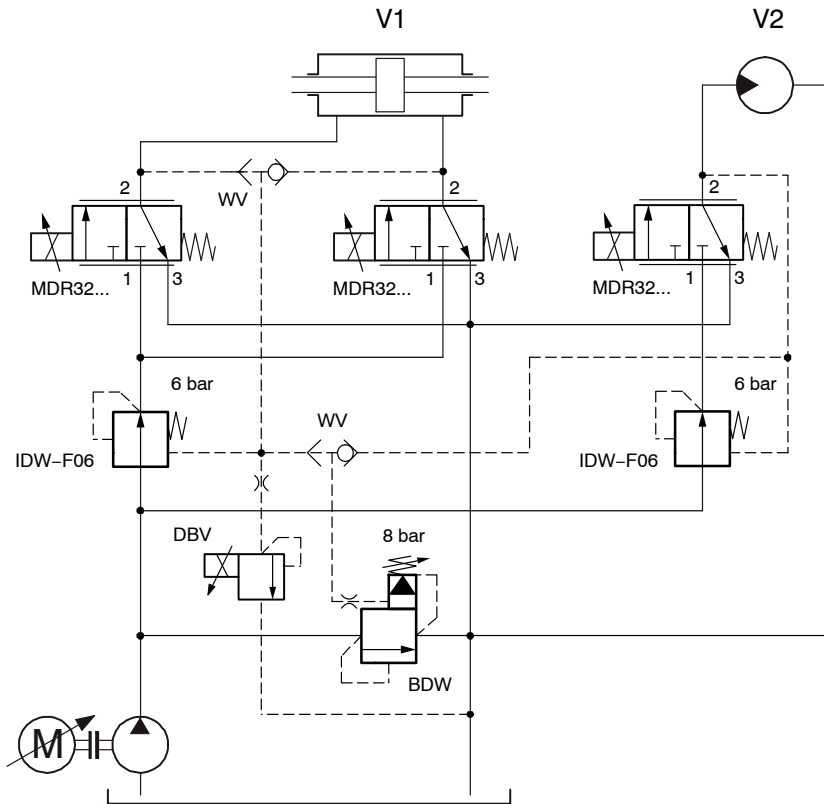

- Only for use with compensator (max. $\Delta p = 15$ bar)
- Full-flow connection 2 → 3
- Control is only available with connection 1 → 2

Special type “S600” – only to be used with compensator

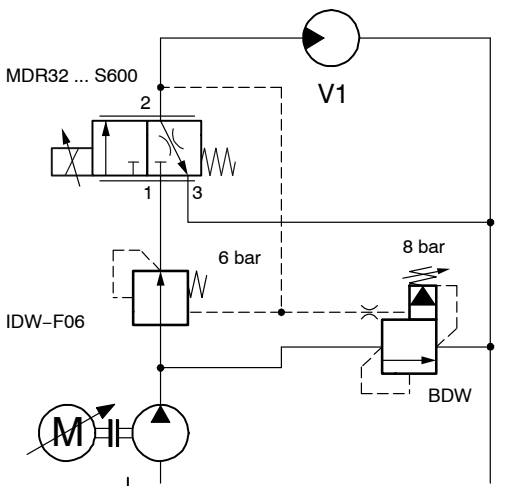

- Only for use with compensator (max. $\Delta p = 15$ bar)
- Connection 2 → 3 is not full flow (suitable for unloading)
- Control is only available with connection 1 → 2

9 Ordering code

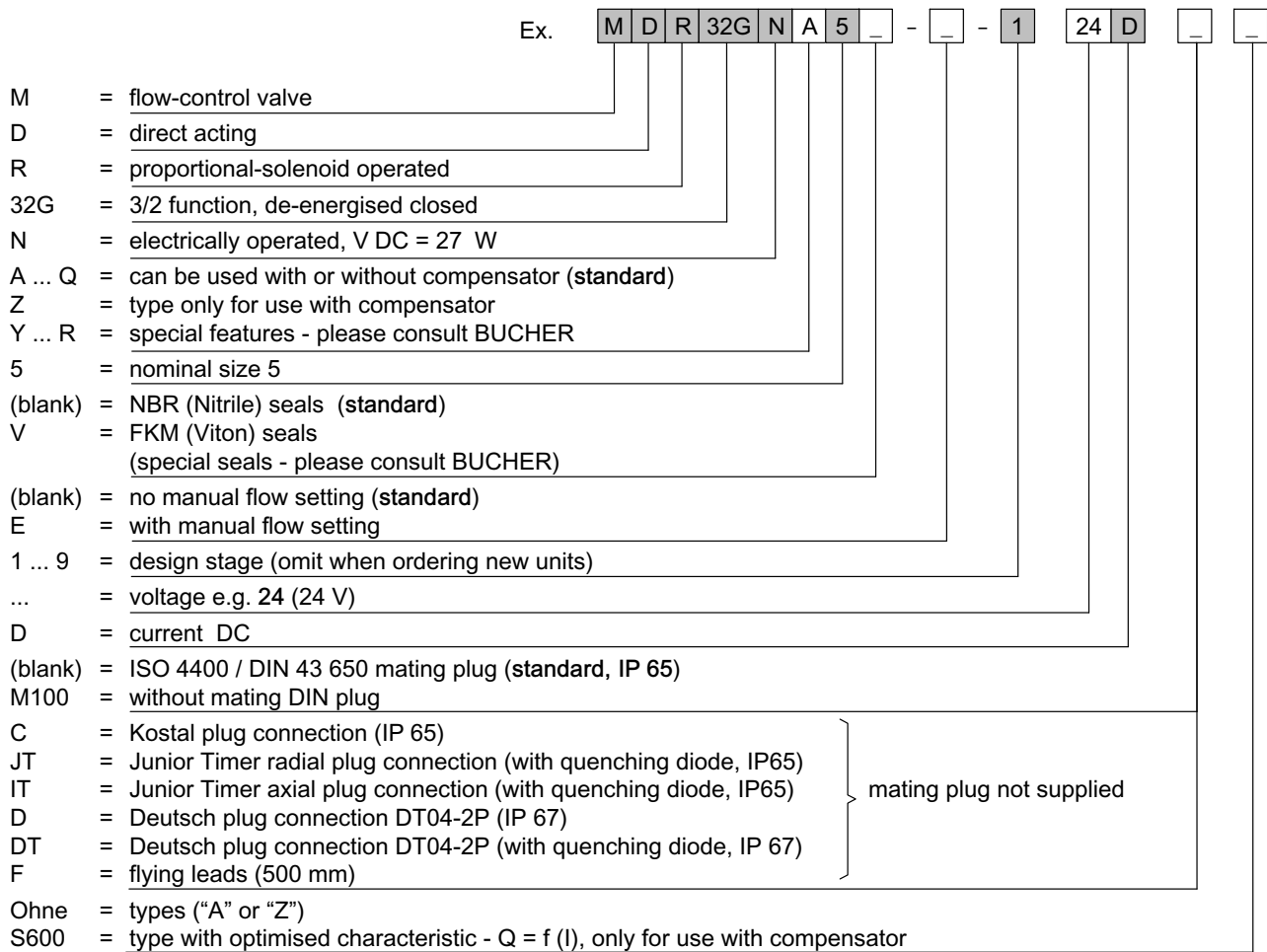

10 Related data sheets

Reference	(Old no.)	Description
400-P-040011	(i-32)	The form-tool hire programme
400-P-040181	(i-33.11)	Cavity type AM
400-P-120110	(W-2.141)	Coils for screw-in cartridge valves
400-P-510101		Amplifier unit for proportional valves (1-channel) PBS - 3A
400-P-511101		Amplifier card for proportional valves (1-channel) SAN-535...
400-P-720111	(G-4.20)	Line-mounting body, type GAMA (G 3/8")

info.ch@bucherhydraulics.com

www.bucherhydraulics.com

© 2012 by Bucher Hydraulics AG Frutigen, CH-3714 Frutigen

All rights reserved.

Data is provided for the purpose of product description only, and must not be construed as warranted characteristics in the legal sense. The information does not relieve users from the duty of conducting their own evaluations and tests. Because the products are subject to continual improvement, we reserve the right to amend the product specifications contained in this catalogue.

Classification: 430.310.325.305.310.310