

# **MURZAN** INC.

## **OPERATION & SERVICE MANUAL**

MURZAN PI-50 PUMP

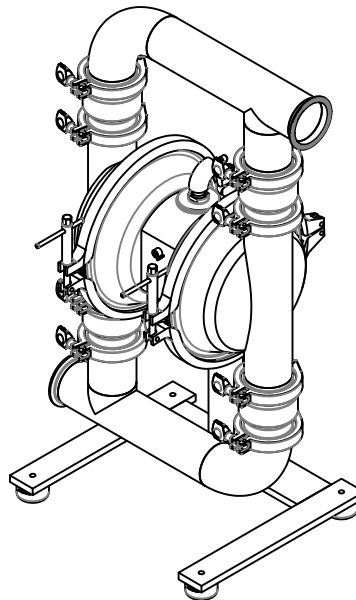

UNIT SERIAL NUMBER

123A

IMPORTANT DOCUMENTATION, DO NOT DISCARD  
SEE DECLARATION OF CONFORMITY AVAILABLE

**MURZAN INC.**

2909 LANGFORD RD. 1-700

NORCROSS, GA 30071

UNITED STATES OF AMERICA

TEL: (770) 448-0583 FAX: (770) 448-0967

# IMPORTANT

Your Murzan pump serial number is printed on the cover page of this manual, and repeated below for your records. Your serial number can also be found on your pump, shown below.

When calling to request parts or information about your Murzan pump, please have your serial number and pump key (both below) ready.

Serial number: 123A

Pump key: PI-50 - SL - V - HV MC - IB3 - 3Mx3M - FG/TF/FG - BDA - HT - S

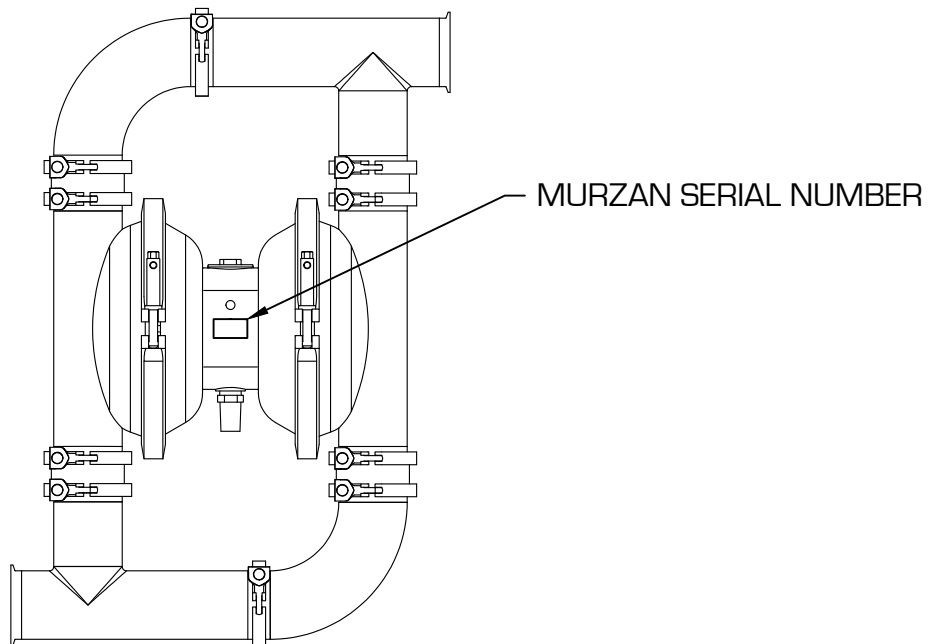

# TABLE OF CONTENTS

1.0 Air Quality .....	1
2.0 Basic Operation .....	2
3.0 Maintenance and Cleaning .....	3
3.1 Clean In Place .....	4
4.0 Pump Subassemblies .....	5
4.1 Center Subassembly .....	8
4.2 Chamber Subassembly .....	10
4.3 Check Valve Subassembly .....	12
4.4 Manifold Subassembly .....	14
5.0 Pump Disassembly .....	16
5.1 Assembly A .....	19
5.2 Assembly B .....	21
5.3 Assembly C .....	23
6.0 Pump Reassembly .....	25
7.0 Troubleshooting .....	29
8.0 Spare Parts .....	30
9.0 Terms of Sale .....	31
10.0 Additional Documents .....	32

## **1.0 AIR QUALITY**

Your Murzan Pump is powered with compressed air at a maximum pressure of 100 PSIG. **DO NOT EXCEED THIS LEVEL**, as damage to the system or personal injury may occur.

Murzan pumps use a non-lubricated air valve system to meet the stringent USDA and FDA standards required for pneumatically operated diaphragm pumps in the food and pharmaceutical industries. Only a Murzan pump gives you this unique feature.

Murzan pumps have been engineered to provide the highest standard of performance and reliability in handling your sanitary products. We at Murzan insure the most hygienic system possible by equipping all Murzan pumps with an oil free, non-lubricated air valve. The patented, non-lubricated Murzan air valve does not exhaust contaminated oil vapor into your plant environment, unlike a lubricated air valve. A clean, well-filtered air supply is essential for the proper operation of the air valve and for the prevention of contaminants being expelled into the plant environment. A dirty oil laden air supply is by far the most expensive and overlooked problem we find in working with our customers.

Oil and other contaminants that enter the pump drastically reduce the life of the air valve, shaft bushing assembly, shaft, and block gaskets. The results are a much higher frequency of parts replacement and repair, with a corresponding increase in maintenance expenses. As pump parts become worn due to contamination, the pump loses efficiency and requires increased air volume to move the product. This puts additional strain on the air supply and brings increasing amounts of oil to the pump. The use of filters will pay for themselves in a very short time through reduced parts usage and maintenance man hours.

## **2.0 BASIC OPERATION**

Your Murzan Pump has wetted parts constructed of 304 or 316 stainless steel and FDA approved elastomers.

When using the pumps in a permanent installation attached to rigid piping, the use of flexible couplings on both the suction and discharge ports of the pump is recommended to reduce vibration due to the reciprocating nature of the pump.

All fittings must be tight in order to eliminate air and product leaks. This will allow the pump to run as efficiently as possible.

The suction pipe diameter should never be less than the diameter of the suction manifold. Larger diameters may be used if extremely viscous materials are to be pumped.

Non-collapsible reinforced hose must be used on the suction side of the pump if hoses are to be used in place of piping.

Should you need to control your pump discharge rate, you may do so by:

1. Limiting the volume and/or pressure of the air supply to the pump. An air regulator installed at the air inlet will serve this purpose.
2. Throttling the pump discharge by installing a valve in the discharge line of the pump. When the discharge pressure equals or exceeds the air supply pressure, the pump will automatically stall, eliminating the need for pressure relief valves. Pump damage will not occur when the pump is stalled.

**Caution: Do not exceed 100 psig air supply pressure.**

**Caution: Maximum temperature limits are based upon both mechanical and corrosive factors. Certain products will significantly reduce maximum safe operating temperatures. Please consult the factory when product compatibility is in question.**

### **3.0 MAINTENANCE & CLEANING**

In general, cleaning requirements and guidelines are set by governmental agencies such as the USDA or FDA in the United States. Each user of Murzan Inc. equipment is responsible for ensuring that their cleaning process and procedures meet the applicable governmental and industry standards.

Murzan Inc. makes every effort to provide equipment that will easily meet governmental cleaning requirements and facilitate internal and external cleaning processes for the customer. However, strict compliance with governmental regulations regarding specific processes and suitable chemicals is the sole responsibility of the customer.

Your Murzan pump consists of two types of parts: wet parts and dry parts.

Wet parts are those that come into contact with the product being pumped; dry parts are those that do not come into contact with the product being pumped.

Wet parts require regular and thorough cleaning. It is strongly recommended to clean all wet parts after every use of your Murzan pump. Throughout the life of your Murzan pump, all non-stainless steel wet parts will require replacement as they wear out with use/time. Refer to section 5.0 on Pump Disassembly with instructions for cleaning the wet parts of your Murzan pump. Additionally, refer to section 8.0 on Spare Parts for more details.

Dry parts require routine inspection and some parts require replacement at recommended intervals of 6 to 12 months. Refer to section 5.0 on Pump Disassembly with instructions for cleaning the dry parts of your Murzan pump. Additionally, refer to section 8.0 on Spare Parts for more details.

### **3.1 CLEAN IN PLACE**

Most plants have their own guidelines for Clean In Place (CIP). Please follow your plant's requirements.

If you are cleaning your Murzan pump along with your piping system at the same time, a bypass hose should be used to provide the additional flow required. It is recommended that the minimum flow rate for CIP of your Murzan pump be 5 ft/sec (1.5 m/s). Please refer to the CIP Diagram in section 10.0.

## **4.0 PUMP SUBASSEMBLIES**

The diagrams on the following two pages identify the four subassemblies that make up your Murzan Pump: the center subassembly, the chamber valve subassembly, the check valve subassembly, and the manifold subassembly. The first diagram shows the four individual subassemblies, and the second diagram shows the complete Murzan pump assembly (exploded view).

Note: the manifolds, check valves, and chambers on the following page may be different than those of your pump. However, the four main subassemblies remain the same for any Murzan pump.

The tables and diagrams in sections 4.1-4.4 give detailed listings of the respective subassembly components, specific to your Murzan pump. These listings will aid in identifying components for operation, cleaning, maintenance and servicing.



### CENTER SUBASSEMBLY

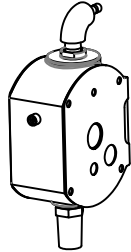

### CHAMBER SUBASSEMBLY

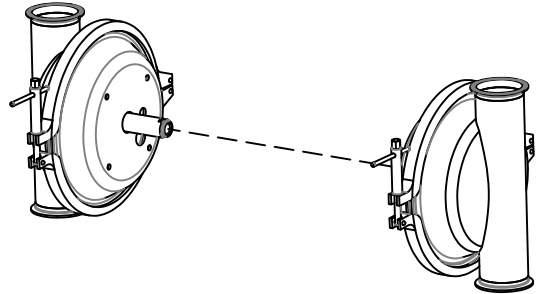

### CHECK VALVE SUBASSEMBLY

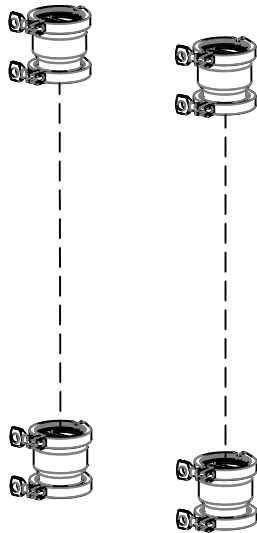

### MANIFOLD SUBASSEMBLY

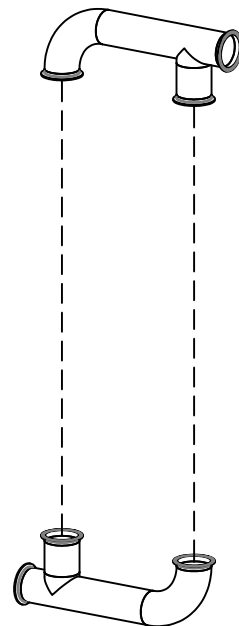

DATE: 12APR17  
 CREATED BY: MKHOURY

DESCRIPTION:  
 PUMP SUB ASSEMBLIES

DRAWING No.

PL10000B

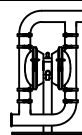

**MURZAN INC.**  
 2909 LANGFORD RD. 1-700  
 NORCROSS, GA. 30071 USA  
 TEL: (770) 448-0583 FAX: (770) 448-0967

# PUMP ASSEMBLY

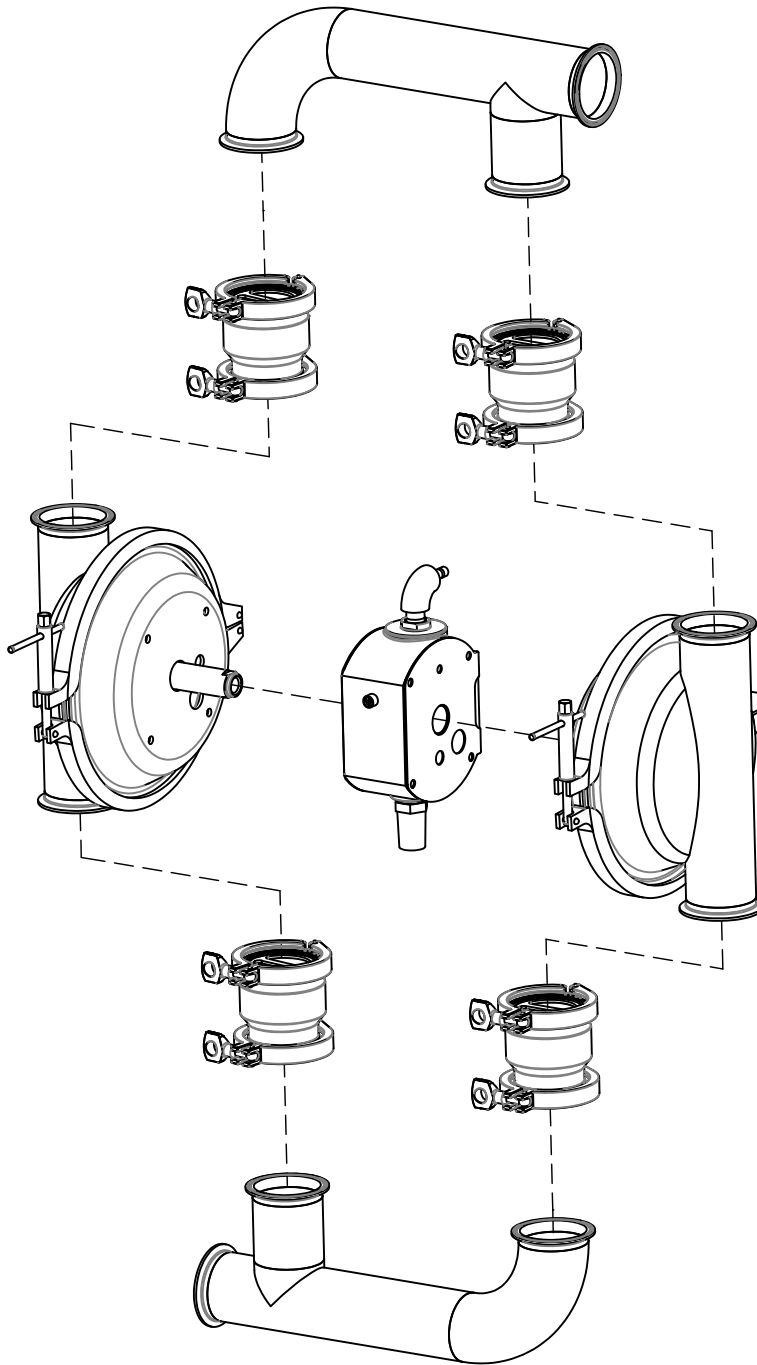

DATE: 12APR17	DESCRIPTION: PUMP SUB ASSEMBLIES
CREATED BY: MKHOURY	
	DRAWING No. PL10000A

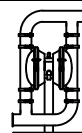

**MURZAN INC.**  
2909 LANGFORD RD. 1-700  
NORCROSS, GA. 30071 USA  
TEL: (770) 448-0583 FAX: (770) 448-0967

## **4.1 CENTER SUBASSEMBLY PARTS**

*(Diagram 1 on next page)*

<b>Part Description</b>	<b>Label #</b>	<b>Part #</b>
MC-V-HT Center Block	1	110011000
MC/LC Block Gasket Set	2	110010071
Assembly A	3	110021000
Assembly B	4	110031000
Assembly C	5	110041000
Air inlet filter	6	110010020
Muffler	7	110010010
Air Connector 1/2"	8	110010030
Nipple 1/2"	9	110010040
SS 90 Elbow 1/2"	10	110010050
Air inlet cap (w/ O-Ring)	11	110051000
3/8-16 x 3/4 Titanium Bolt w/ washer	12	110080051

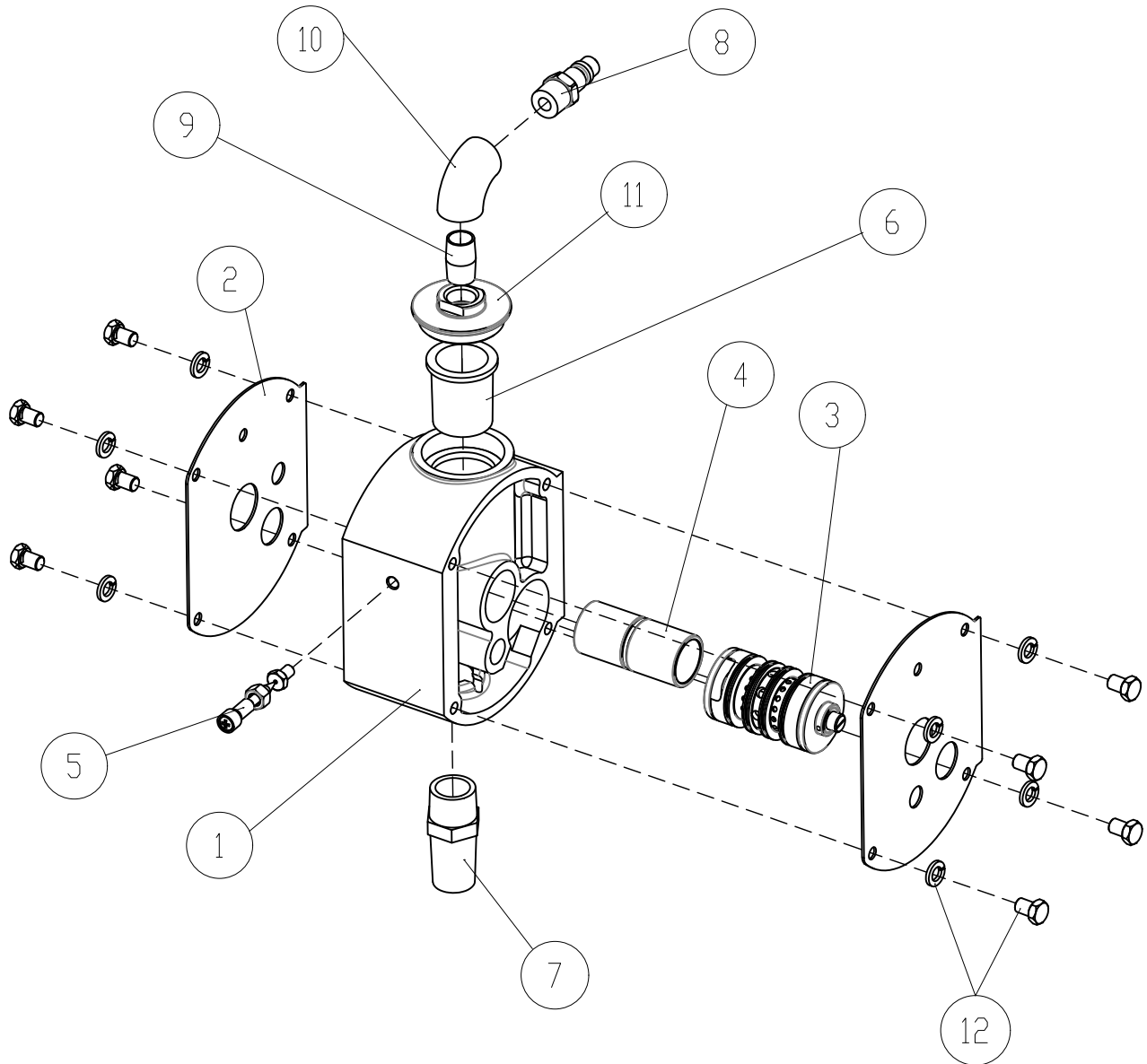

DIAGRAM NO. 1

**PROPRIETARY INFORMATION**  
 THIS DOCUMENT IS THE PROPERTY OF MURZAN, INCORPORATED. THE INFORMATION CONTAINED HEREIN IS CONFIDENTIAL AND PRESENTED TO SAID CUSTOMER FOR REVIEW OR APPROVAL. UNDER NO CIRCUMSTANCES SHOULD THIS DOCUMENT BE REPRODUCED OR LOANED TO ANY THIRD PARTY WITHOUT THE WRITTEN PERMISSION OF MURZAN, INCORPORATED

NOTES:  
 1. THIS DRAWING IS FOR REFERENCE ONLY.

REV	DESCRIPTION	DATE	BY	APP

DATE: 12APR17	DESCRIPTION: MC (VERTICAL) CENTER SUBASSEMBLY
CREATED BY: MKHOURY	DRAWING NO. PL10004A



**MURZAN INC.**  
 2909 LANGFORD RD. 1-700  
 NORCROSS, GA. 30071 USA  
 TEL: (770) 448-0583 FAX: (770) 448-0967

## **4.2 CHAMBER SUBASSEMBLY PARTS**

*(Diagram 2 on next page)*

<b>Part Description</b>	<b>Label #</b>	<b>Part #</b>
MC BDA FG Diaphragm	1	110091010
HV MC 3" Product Chamber	2	110103300
Air Chamber MC	3	110081000
MC Shaft	4	110061000
MC BDA Piston Inner	5	110070110
MC BDA Piston Outer	6	110071100
Piston Inner Washer MC/LC	7	110070011
MC Chamber Clamp	8	110121000
SC/MC Wingnut	9	110110400
Flatwasher 1/4-20	10	110080061
Lockwasher 1/4-20	10	110080071
Jam Nut 1/4-20	10	110080081

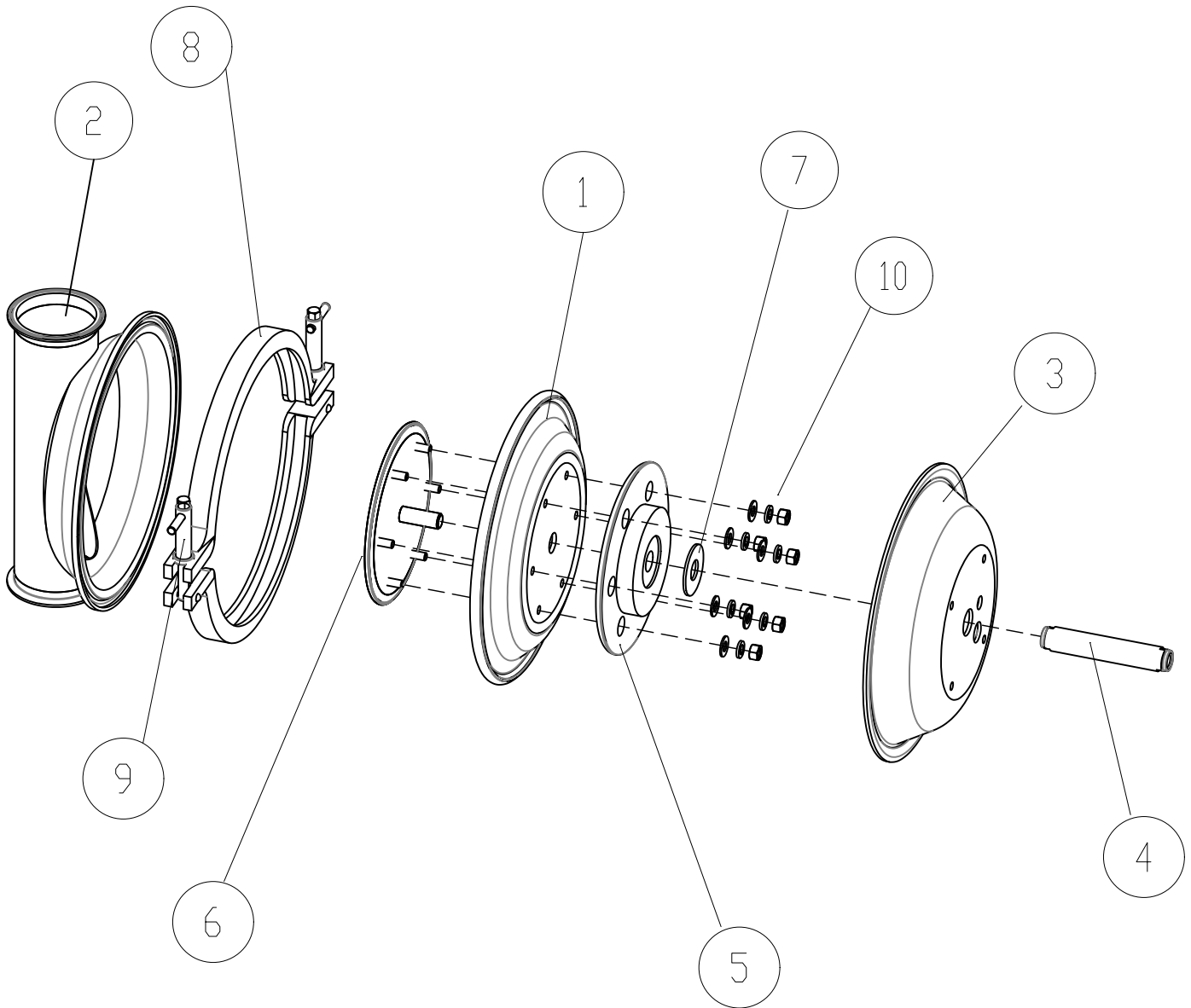

NOTE: ONLY ONE SHAFT PER PUMP

DIAGRAM NO. 2

**PROPRIETARY INFORMATION**  
 THIS DOCUMENT IS THE PROPERTY OF MURZAN, INCORPORATED. THE INFORMATION CONTAINED HEREIN IS CONFIDENTIAL AND PRESENTED TO SAID CUSTOMER FOR REVIEW OR APPROVAL. UNDER NO CIRCUMSTANCES SHOULD THIS DOCUMENT BE REPRODUCED OR LOANED TO ANY THIRD PARTY WITHOUT THE WRITTEN PERMISSION OF MURZAN, INCORPORATED

NOTES:  
 1. THIS DRAWING IS FOR REFERENCE ONLY.

REV	DESCRIPTION	DATE	BY	APP

DATE: 12APR17  
 CREATED BY: MKHOURY

DESCRIPTION:  
 HV BDA CHAMBER SUBASSEMBLY

DRAWING No. PL10007A



**MURZAN INC.**  
 2909 LANGFORD RD. 1-700  
 NORCROSS, GA. 30071 USA  
 TEL: (770) 448-0583 FAX: (770) 448-0967

### **4.3 CHECK VALVE SUBASSEMBLY PARTS**

*(Diagram 3 on next page)*

<b>Part Description</b>	<b>Label #</b>	<b>Part #</b>
2 1/4" Ball HF	1	110153310
3" Ball/Mushroom Housing	2	110143300
3" Ball Stop	3	110156300
3" Clamp	4	110124300
3" FG Gasket	5	110095300

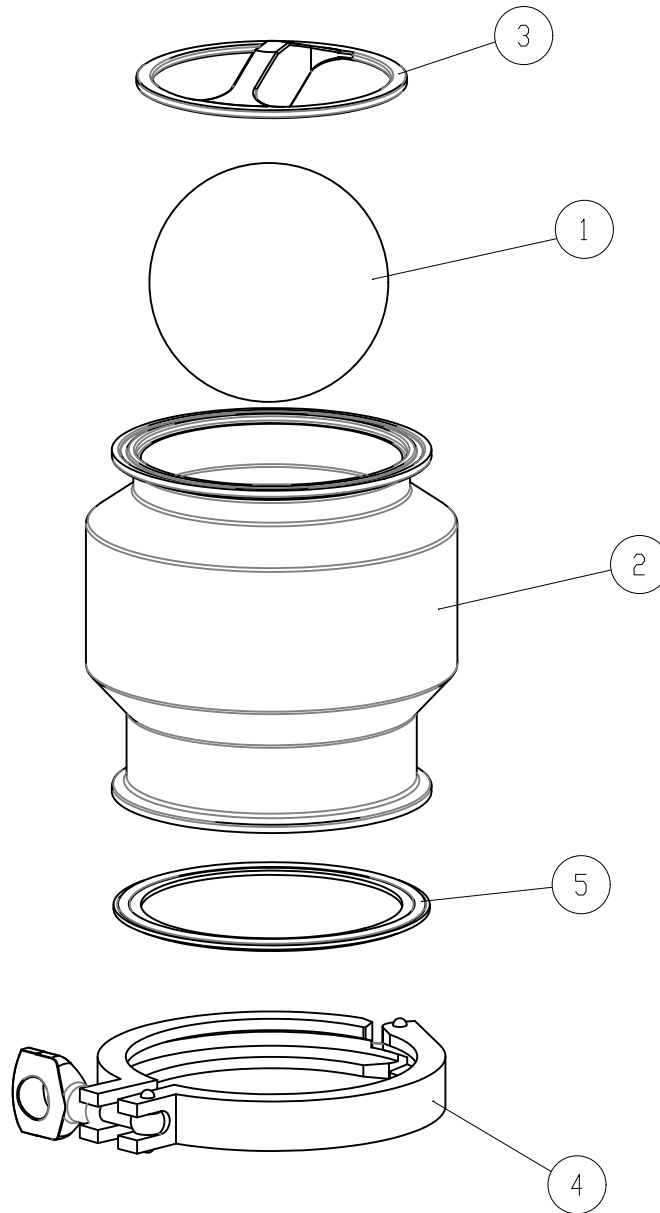

DIAGRAM NO. 3

**PROPRIETARY INFORMATION**  
 THIS DOCUMENT IS THE PROPERTY OF MURZAN, INCORPORATED. THE INFORMATION CONTAINED HEREIN IS CONFIDENTIAL AND PRESENTED TO SAID CUSTOMER FOR REVIEW OR APPROVAL. UNDER NO CIRCUMSTANCES SHOULD THIS DOCUMENT BE REPRODUCED OR LOANED TO ANY THIRD PARTY WITHOUT THE WRITTEN PERMISSION OF MURZAN, INCORPORATED

NOTES:  
 1. THIS DRAWING IS FOR REFERENCE ONLY.

REV	DESCRIPTION	DATE	BY	APP

DATE: 12APR17	DESCRIPTION: IB CHECK VALVE
CREATED BY: MKHOURY	DRAWING No. PL10020A



**MURZAN INC.**  
 2909 LANGFORD RD. 1-700  
 NORCROSS, GA. 30071 USA  
 TEL: (770) 448-0583 FAX: (770) 448-0967



#### **4.4 SUCTION/DISCHARGE MANIFOLD SUBASSEMBLY PARTS**

*(Diagram 4 on next page)*

<b>Part Description</b>	<b>Label #</b>	<b>Part #</b>
3"x 3" 90 Elbow	1	110193300
3" Tee, MC M Manifold	2	110181330
3" Clamp	3	110124300
3" FG Gasket	4	110095300

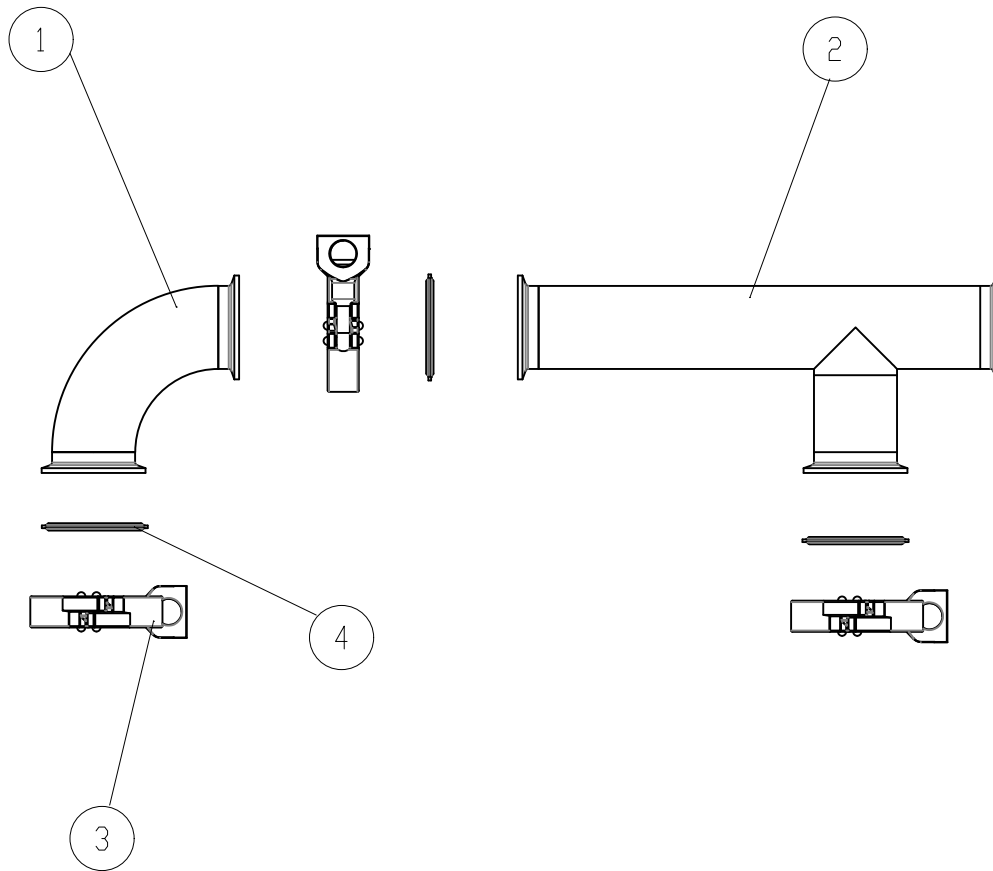

DIAGRAM NO. 4

**PROPRIETARY INFORMATION**  
 THIS DOCUMENT IS THE PROPERTY OF MURZAN, INCORPORATED. THE INFORMATION CONTAINED HEREIN IS CONFIDENTIAL AND PRESENTED TO SAID CUSTOMER FOR REVIEW OR APPROVAL. UNDER NO CIRCUMSTANCES SHOULD THIS DOCUMENT BE REPRODUCED OR LOANED TO ANY THIRD PARTY WITHOUT THE WRITTEN PERMISSION OF MURZAN, INCORPORATED

NOTES:  
 1. THIS DRAWING IS FOR REFERENCE ONLY.

REV	DESCRIPTION	DATE	BY	APP

DATE: 12APR17	DESCRIPTION: M MANIFOLD
CREATED BY: MKHOURY	DRAWING No. PL10012A



**MURZAN INC.**  
 2909 LANGFORD RD. 1-700  
 NORCROSS, GA. 30071 USA  
 TEL: (770) 448-0583 FAX: (770) 448-0967

## **5.0 PUMP DISASSEMBLY**

The following section details the disassembly of your Murzan PI-50 pump. The disassembly process is divided in two parts, as mentioned in the earlier section on maintenance: disassembly of wet pump parts (for cleaning) followed by disassembly of dry pump parts (for maintenance).

Pump parts are referenced in the instructions to follow using the following notation: Diagram #/Item #. (For example, 4/2 refers to Diagram #4, Item #2.)



Before attempting any cleaning and/or maintenance, disconnect the air supply. Be sure to wear and use personal protective equipment and take necessary safety precautions.

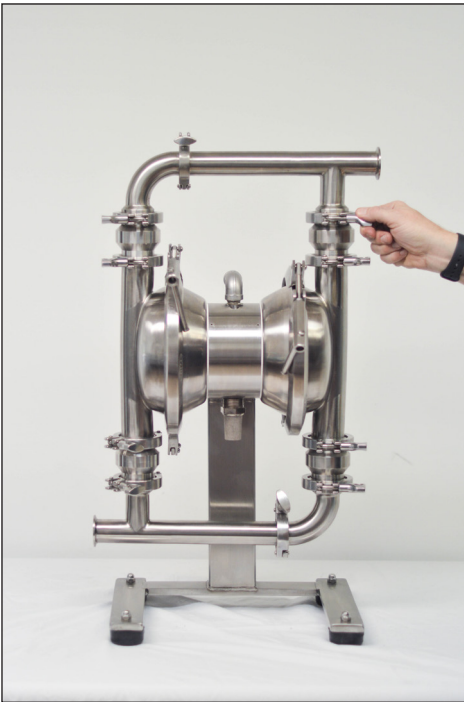

1. Remove clamps (4/3) and gaskets (4/4) that connect the suction manifold to the suction check valves.



2. Remove suction manifold. Repeat for discharge manifold.

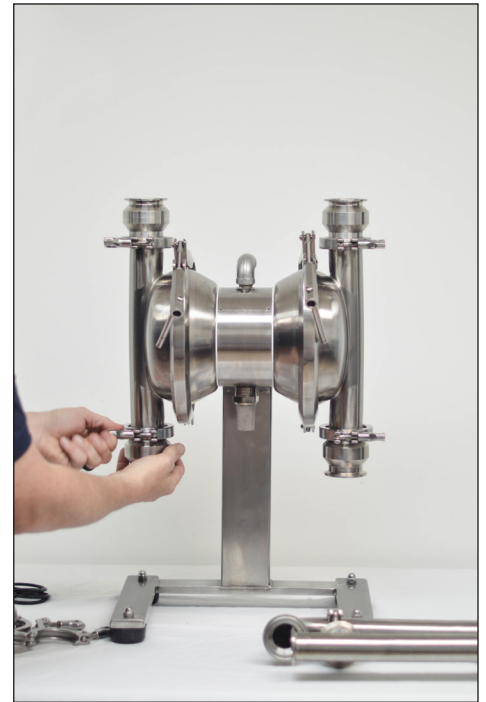

3. Remove all four ball housings (3/2) by removing clamps (3/4) and gaskets (3/5). Then remove balls (3/1) and ball stoppers (3/3) from all check valves.



4. Loosen left product chamber clamp (2/8) by turning clamp handle (2/9).



5. Remove left product chamber clamp and left product chamber (2/2). Repeat for right product chamber. Both pump diaphragms (2/1) are now exposed.



All wet parts of your Murzan pump are now exposed for inspection and cleaning. Continue reading only for inspection and service of dry parts. To reassemble wet parts, skip to step 6 of section 6.0 on Pump Reassembly.

*(Pump disassembly, continued.)*

To continue pump disassembly, you will need the following tools:

- . (2) 3/4" Open end wrench
- . (1) 1" Combination wrench
- . (1) Adjustable wrench
- . (1) Ratchet with extension
- . (1) 9/16" Socket
- . (1) 7/16" Socket

6. To remove diaphragms, place a 3/4" open end wrench on each of the outer pistons and loosen. This will allow the diaphragms, inner pistons (2/5), outer pistons (2/6), and shaft (2/4) to be removed. Make sure to set aside the piston inner washers (2/7) for reassembly. Use the 7/16" socket, ratchet and extension to separate the diaphragms from the outer pistons by removing the nuts (2/10).

7. Remove both air chambers (2/3) from the center block (1/1) by removing the bolts (1/12) using the 9/16" socket, ratchet and extension.

*Note: Once the air chambers are removed, you must replace both block gaskets (1/2) before reassembling your pump. Block gaskets are intended ONLY for one time use/compression, and should not be reused. Refer to section 8.0 on Spare Parts to order block gaskets.*

8. Remove the center block gaskets. Inspect the center block for any debris. Clean if necessary. Use the 1" wrench to remove the air inlet cap (1/11). Remove the air inlet filter (1/6) to inspect for any debris. If dirty or discolored, replace the air inlet filter. If the muffler (1/7) is dirty or discolored, replace the muffler. Use the adjustable wrench to remove the muffler. Do not reuse dirty/discolored air inlet filters or mufflers, as this may result in poor performance of your pump. Refer to Section 8.0 on Spare Parts.

9. Refer to Sections 5.1 and 5.2 for instructions on how to replace Assemblies A, B and C.

## **5.1 ASSEMBLY A**

The Assembly A is a wear part and will require replacement. We recommend replacement at least every 6 to 12 months depending on use of pump, for optimal pump performance. If your pump is shifting erratically or stalling, replace Assembly A immediately.

The following instructions will guide you through the disassembly and reassembly of Assembly A. An annotated, exploded view of Assembly A can be seen on the following page in Diagrams A1-A4. To begin disassembly and reassembly of Assembly A, you will need the following tools:

- . (2) *Flat Head Screw Driver (1/4" to 3/8" head)*
- . (1) *Assembly A installation tool (ships with spare Assembly A)*

1. Insert two flat head screwdrivers into the air valve actuator slots and turn counterclockwise to loosen air valve caps.
2. Remove all pieces of Assembly A. Use Diagram A1 for reference.
3. Before reassembling a new Assembly A, apply small amounts of food grade lubricant on ONLY the four O-rings of the air valve cylinder.
4. Line up the air valve cylinder notch with the notch on the center block. Refer to Diagram A2 for this alignment. Make sure the air valve cylinder is well aligned.
5. Next, press the air valve cylinder into the center block using the supplied installation tool. Refer to Diagram A2. Ensure the air valve cylinder is correctly recessed by 0.2" from both faces of the center block, as shown in Diagram A3.
6. Reassemble Assembly A, using Diagram A4 as a reference, and tighten the air valve actuator and air valve insert pieces with two flat head screwdriver drivers. Make sure that the air valve caps are flush with the outer surfaces of the center block.

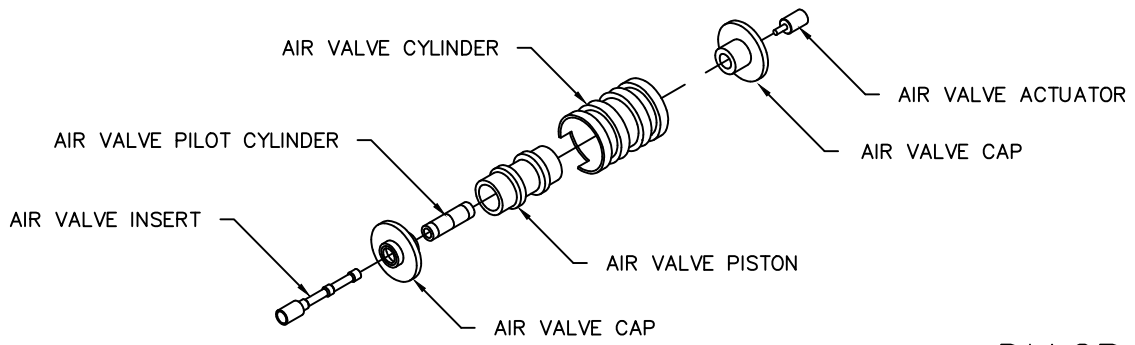

DIAGRAM A1

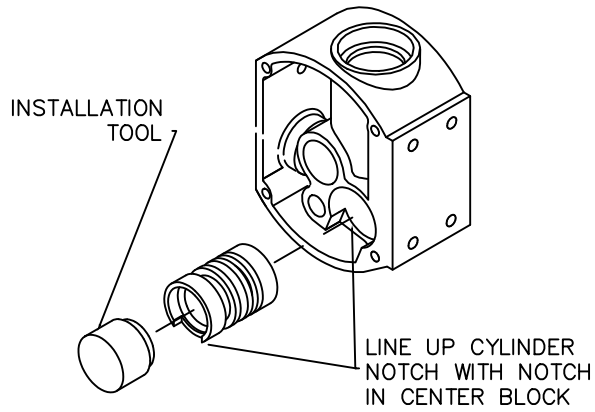

DIAGRAM A2

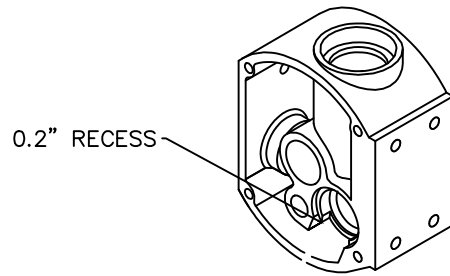

DIAGRAM A3

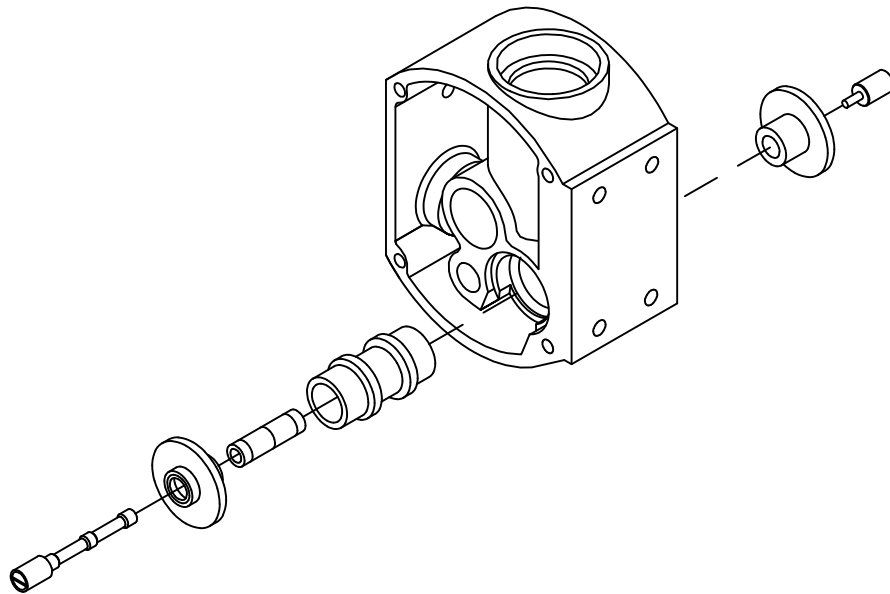
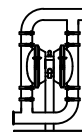

DIAGRAM A4

DATE: 12APR17	DESCRIPTION: ASSEMBLY A, ASSEMBLY
CREATED BY: MKHOURY	
	DRAWING NO. PL20003A



**MURZAN INC.**  
 2909 LANGFORD RD. 1-700  
 NORCROSS, GA. 30071 USA  
 TEL: (770) 448-0583 FAX: (770) 448-0967

## **5.2 ASSEMBLY B**

Assembly B should be replaced whenever Assembly A is replaced, or every 6 to 12 months for optimal pump performance. The following instructions will guide you through disassembly and reassembly of Assembly B, shown on the following page in Diagram B. To begin disassembly and reassembly of Assembly B, you will need the following tool:

. (1) *Assembly B installation tool (ships with spare Assembly B)*

1. Use the installation tool, as oriented in Diagram B, to press Assembly B out from the center block.
2. Inspect all components. If necessary, a spare Assembly B can be ordered for replacement. Refer to Section 8.0 for spare parts.
3. To reassemble Assembly B, begin by pressing one shaft bushing into the center block until it is flush with the outer face of the center block. Refer to Diagram B as needed for the following steps.
4. Place the shaft seal ring in the recessed groove at the end of the installation tool. Then place the shaft o-ring around the shaft seal ring. Apply small amounts of food grade lubricant on the O-ring. Carefully press the seal ring and o-ring into the center block until both rings contact the inserted shaft bushing.
5. Press the second shaft bushing into the center block. Ensure both shaft bushings are flush with both faces of the center block.



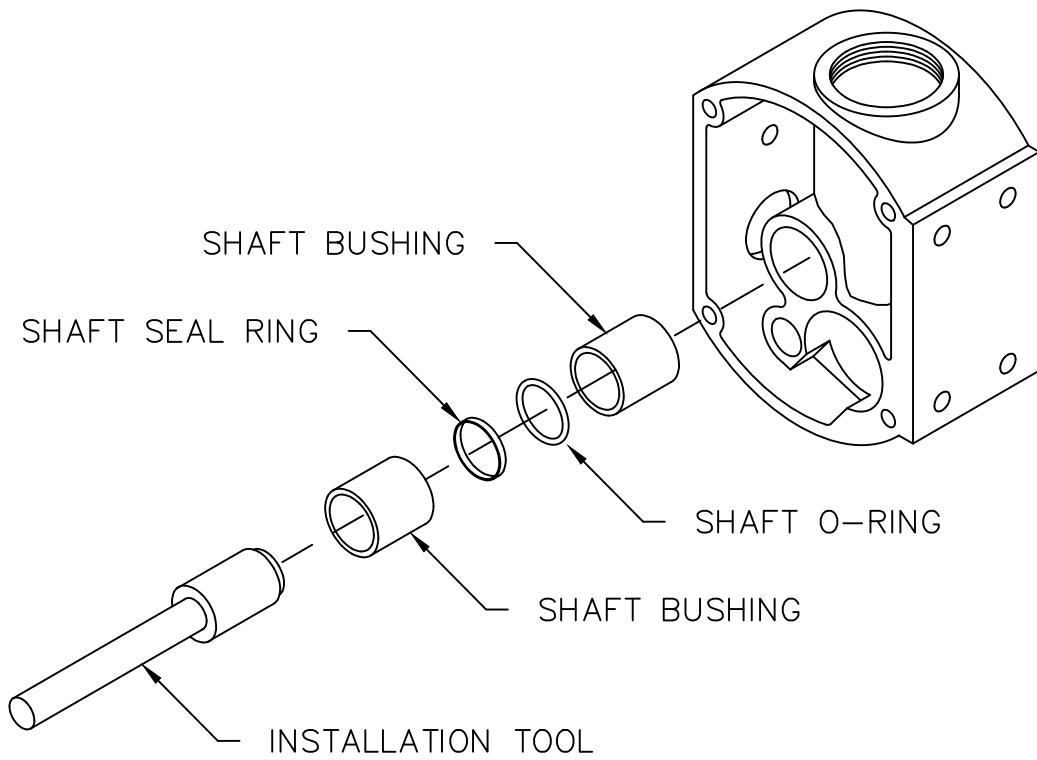

DIAGRAM B

**PROPRIETARY INFORMATION**  
 THIS DOCUMENT IS THE PROPERTY OF MURZAN, INCORPORATED. THE INFORMATION CONTAINED HEREIN IS CONFIDENTIAL AND PRESENTED TO SAID CUSTOMER FOR REVIEW OR APPROVAL. UNDER NO CIRCUMSTANCES SHOULD THIS DOCUMENT BE REPRODUCED OR LOANED TO ANY THIRD PARTY WITHOUT THE WRITTEN PERMISSION OF MURZAN, INCORPORATED

NOTES:  
 1. THIS DRAWING IS FOR REFERENCE ONLY.

REV	DESCRIPTION	DATE	BY	APP

DATE: 12APR17	DESCRIPTION: ASSEMBLY B
CREATED BY: MKHOURY	DRAWING No. PL20005A

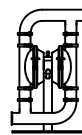

**MURZAN INC.**  
 2909 LANGFORD RD. 1-700  
 NORCROSS, GA. 30071 USA  
 TEL: (770) 448-0583 FAX: (770) 448-0967

## **5.3 ASSEMBLY C**

Assembly C does not normally require replacement. These instructions will guide you through disassembly and reassembly of Assembly C, shown on the following page in Diagram C. To begin disassembly and reassembly of Assembly C, you will need the following tool:

. (1) *Phillips Head Screw Driver*

1. Loosen and remove the needle valve. Inspect all components of Assembly C, with reference to Diagram C.
2. If replacement is required, loosen and remove the needle nut. Next, loosen and remove the needle bushing and needle seat.
3. Before beginning reassembly of Assembly C, apply liberal amounts of Teflon thread sealant to the threads of the needle bushing and needle valve.
4. Install the needle seat. Do not overtighten.
5. Install the needle bushing. Next, install the needle nut and tighten.
6. Lastly, install the needle valve and tighten.

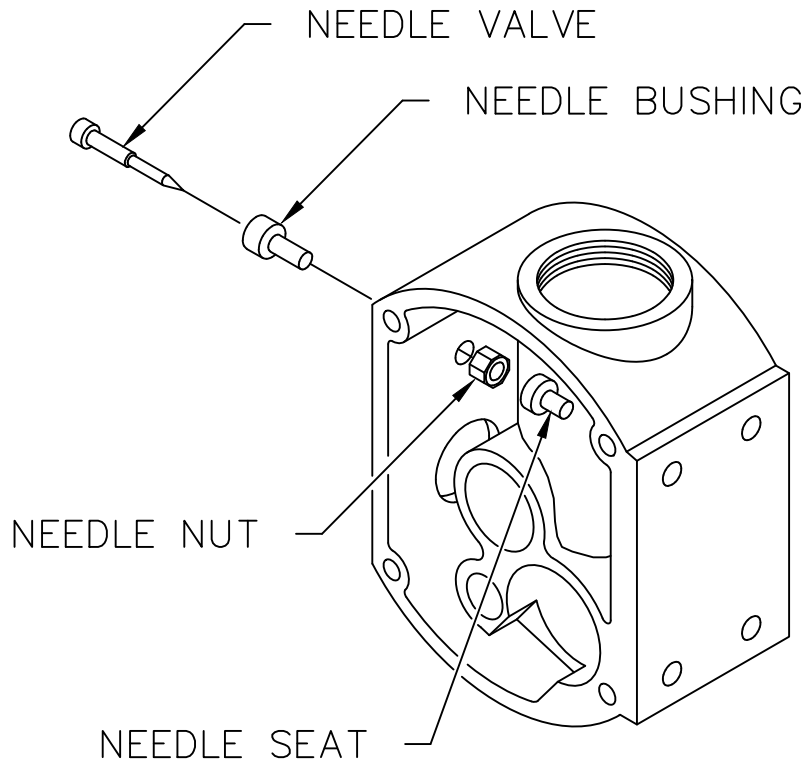

DIAGRAM C

PROPRIETARY INFORMATION

THIS DOCUMENT IS THE PROPERTY OF MURZAN, INCORPORATED. THE INFORMATION CONTAINED HEREIN IS CONFIDENTIAL AND PRESENTED TO SAID CUSTOMER FOR REVIEW OR APPROVAL. UNDER NO CIRCUMSTANCES SHOULD THIS DOCUMENT BE REPRODUCED OR LOANED TO ANY THIRD PARTY WITHOUT THE WRITTEN PERMISSION OF MURZAN, INCORPORATED

NOTES:

1. THIS DRAWING IS FOR REFERENCE ONLY.

REV	DESCRIPTION	DATE	BY	APP

DATE: 12APR17	DESCRIPTION: ASSEMBLY C
CREATED BY: MKHOURY	DRAWING NO. PL20006A

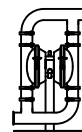

**MURZAN INC.**  
 2909 LANGFORD RD. 1-700  
 NORCROSS, GA. 30071 USA  
 TEL: (770) 448-0583 FAX: (770) 448-0967

## **6.0 PUMP REASSEMBLY**

Pump parts are referenced in the instructions below using the following notation: Diagram #/Item #. (For example, 4/2 refers to Diagram #4, Item #2.) For pump reassembly of wet parts, skip ahead to step 6. To begin pump reassembly of dry parts, you will need the following tools:

- . (1) *Torpedo level*
- . (2) *3/4" Open end wrench*
- . (1) *1" Combination wrench*
- . (1) *Adjustable wrench*
- . (1) *Ratchet with extension*
- . (1) *9/16" Socket*
- . (1) *7/16" Socket*

1. After Assemblies A, B and C are installed, use the adjustable wrench to install the muffler (1/7). Next, position the air inlet filter (1/6), and use the 1" combination wrench to install the air inlet cap (1/11) back onto the center block (1/1).

2. Install the center block gaskets (1/2).

3. Install the air chambers (2/3) on both sides of the center block with the bolts (1/12) using the 9/16" socket, ratchet and extension.

4. Assemble one diaphragm (2/1), inner piston (2/5), and outer piston (2/6) to one side of the shaft (2/4). Make sure you align the diaphragm correctly. (One face of the diaphragm is labelled 'AIR SIDE'. Make sure this face is in contact with the inner piston. Use the 7/16" socket, ratchet and extension to attach the diaphragm to the outer pistons with the nuts (2/10). Make sure the piston inner washer (2/7) is correctly positioned in the recessed edge at the end of the shaft. Push this assembly through the center block, attach the opposite diaphragm, inner piston, outer piston, and inner piston washer and tighten securely using two 3/4" open end wrenches.

5. Slide the shaft/piston assembly entirely to one side, so that one diaphragm is as far from the center block/air chamber as possible, and the other diaphragm is nested in the opposite air chamber. Fold the diaphragm furthest from the center block inwards (towards the center block) so that the outer rim of the diaphragm sits in the concave groove along the inner rim of the air chamber.

All dry parts of the pump are now reassembled. The following instructions detail the reassembly of the pump wet parts.

*(Pump reassembly continues on next page.)*



6. Place one of the product chambers (2/2) over the diaphragm, aligned with the air chamber. Install the product chamber clamp (2/8) and tighten the clamp handle (2/9) just enough to hold the product chamber in place. Use a torpedo level to ensure that the product chamber tube is perfectly perpendicular to the floor and then fully tighten the clamp handle.

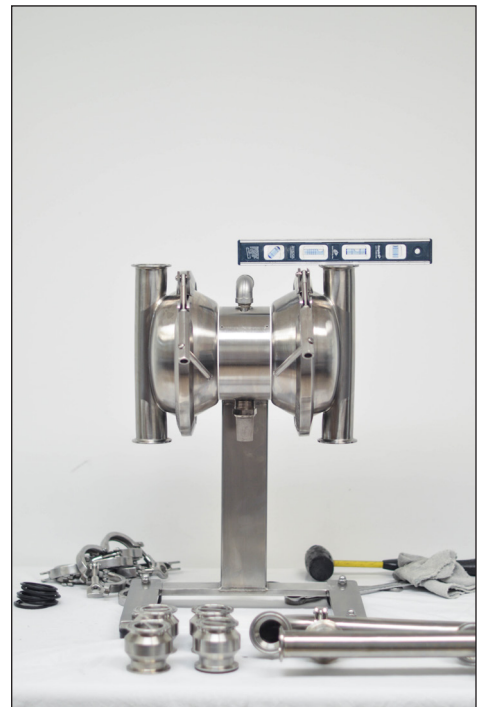
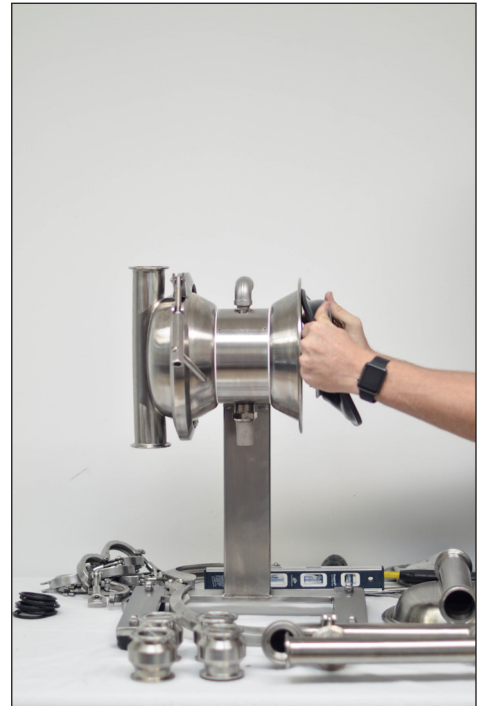
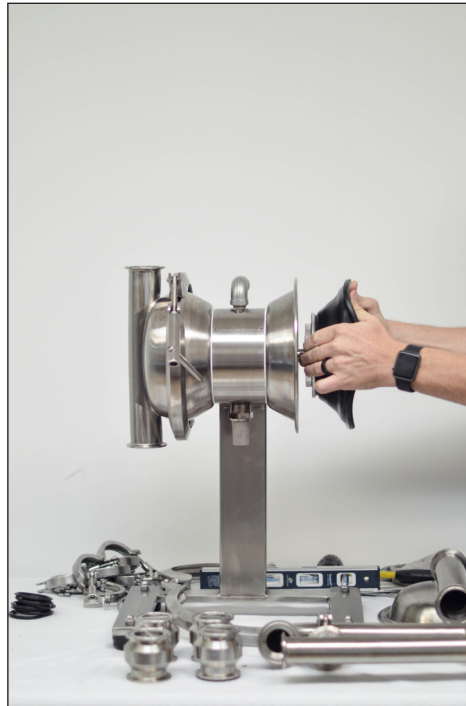
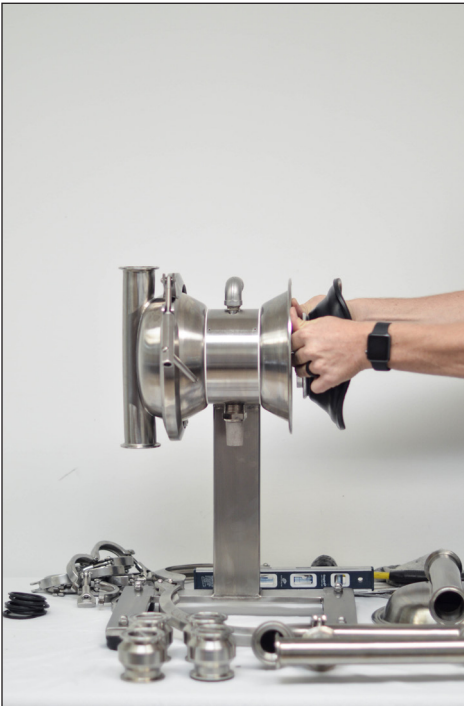

7. Pull the opposite piston assembly through to the exposed air chamber. Again, fold the diaphragm inwards until it is flush with the air chamber. Place the product chamber over the diaphragm, install the product chamber clamp and tighten the clamp handle just enough to hold the product chamber in place. Again, check the level of the product chamber. Fully tighten the product chamber clamp.

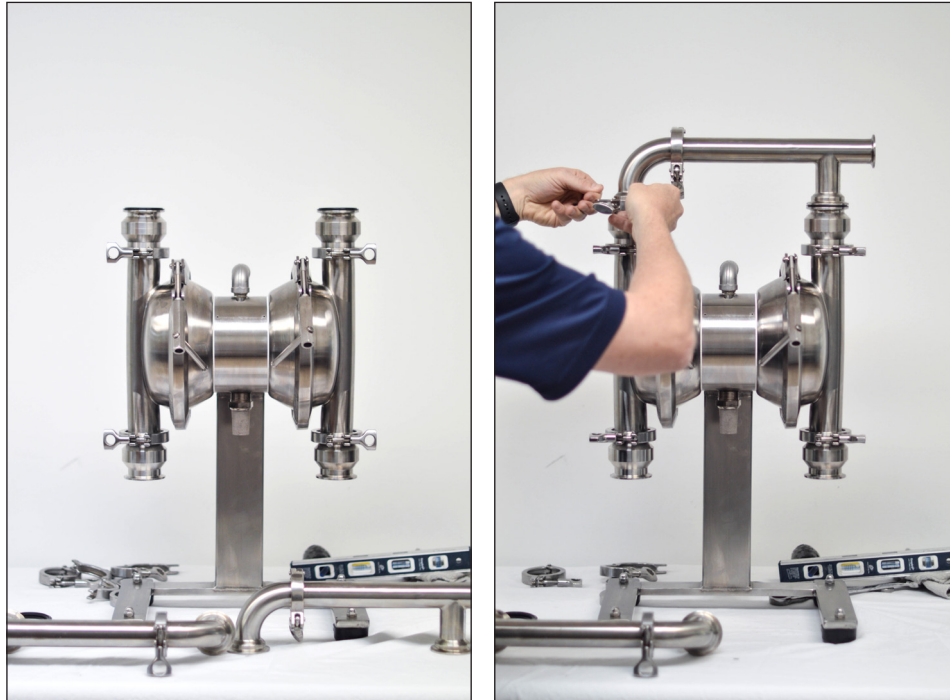

8. Insert balls (3/1) and stoppers (3/3) into the four housings (3/2) and install onto the product chambers using gaskets (3/5) and clamps (3/4). (Shown above, left)

9. Install the suction manifold using clamps (4/3) and gaskets (4/4). (Shown above, right)

10. Repeat for the discharge manifold. Make sure that all clamps have been properly tightened and then reconnect the air supply line to the pump. Run the pump dry (without product) for a moment to make sure that the pump is functioning correctly.

*Note: Occasionally, over-tightening clamps during the re-assembly process can cause a misalignment in the chambers, check valve housings, manifolds, etc. If this should occur, loosen (do not remove) ALL clamps. Never tighten one clamp entirely, but instead tighten all clamps gradually together.*

## **7.0 TROUBLESHOOTING**

This section describes possible problems that could be encountered with your Murzan pump, as well as a list of possible causes and solutions. Contact Murzan for additional support.

### **Pump will not cycle**

- Check for adequate air supply (air pressure and volume)
- Check for blocked product chamber, suction line, or discharge lines
- Check for torn diaphragm, damaged Assembly A or warped outer piston

### **Pump stops during Operation**

- Check for torn diaphragms or loose inner/outer pistons
- Check for worn pump Assembly A or Assembly B
- Check that sensors are properly connected
- Check for blockage in valves, product chamber, suction line, or discharge lines

### **Pump cycles but has no product flow**

- Check for suction side air leak or blocked suction line
- Check for worn block gaskets (as they may result in air leaks)
- Check for blocked, stuck, or missing suction or discharge check valves

### **Pump cycles but has low product flow**

- Check for adequate air supply (air pressure and volume)
- Check for suction side air leak or partial blockage suction line
- Check for blocked, stuck, or missing suction or discharge valves
- Check for worn pump Assembly A or Assembly B
- Check for worn block gaskets (as they may result in air leaks)
- Check that the air filter in the center block is free of debris
- Check that the muffler is free of debris

### **Product comes out of air exhaust**

- Check for loose inner/outer pistons
- Check for warped inner/outer pistons
- Check for punctured diaphragms



## **8.0 SPARE PARTS**

In many processing facilities requiring high product output, you may find it necessary to purchase spare parts to avoid unplanned down time.

The following parts, specific to your Murzan pump, typically need replacing during years of continual service.

<b>Part #</b>	<b>Subassembly</b>	<b>Description</b>	<b>Qty.</b>	<b>Reference*</b>
110021000	Center	Assembly A	1	1/3
110031000	Center	Assembly B	1	1/4
110010071	Center	MC/LC Block Gasket Set	1	1/2
110010020	Center	Air inlet filter	1	1/6
110010010	Center	Muffler	1	1/7
110091010	Chamber	MC BDA FG Diaphragm	2	2/1
110153310	Valve	2 1/4" Ball HF	4	4/1
110156300	Valve	3" Ball Stop	2	4/3

\*Spare parts are referenced using the following notation: Diagram #/Item #.  
(For example, 4/2 refers to Diagram #4, Item #2.)

Note: Please call Murzan for prices of parts listed above.

## **9.0 TERMS OF SALE**

### **TERMS OF PAYMENT**

Terms of payment are as specified in the quotation. If terms of payment are not specifically stated to be otherwise, they are net thirty (30) days from the date of shipment.

### **PRICES**

Prices are firm for thirty (30) days unless stated otherwise.

Prices do not include any Federal, State or local sales or use taxes or insurance which may apply to sale.

All prices are F.O.B. Norcross Georgia.

Typographical and stenographic errors are subject to correction.

### **DELIVERY**

All shipping dates are tentative based on current equipment availability. Murzan, Inc. is not responsible for damages or losses due to delays for any cause.

### **CHANGES**

Notice the changes in orders must be made and confirmed in writing.

### **INSPECTION OF EQUIPMENT**

Upon arrival of the equipment at the customer's facilities, or at any other place at which the customer has ordered the equipment delivered in accordance with the order, the customer shall immediately inspect the equipment and shall give written notice to Murzan, Inc. within five days after arrival of the equipment of any claim that the equipment does not conform with the specifications or the terms of the order.

### **RETURNS**

Orders accepted by the customer cannot be returned without prior written consent from an authorized individual of Murzan, Inc. and a Returned Goods Number, and will be subject to 25% Restocking Charge. Shipping charges on authorized returns are to be prepaid by the Customer unless otherwise specified.

### **CANCELLATIONS**

In the event this quotation results in an order which is canceled or terminated by the customer, the customer agrees to pay to Murzan, Inc. an amount in cash equal to 20% of the total price of the order or contract, plus the actual cost of labor, materials, overhead and related direct costs and expenses incurred by Murzan, Inc. in connection with the order, it being impossible to ascertain or estimate the entire or exact cost, damage or injury which Murzan, Inc. may sustain by reasons of cancellation, and such sum is agreed to as reasonable compensation and not as a penalty.

### **LIMIT OF LIABILITY**

Murzan, Inc. is not liable or responsible for any loss, damage, injury to person or property or any direct or consequential damage arising from sale, installation, or use of this equipment.

Murzan, Inc. shall not be held liable for any losses or damages to the customer resulting from the improper operation, care or cleaning of this equipment.

Murzan, Inc. is not liable for any damage to process or product due to failure of the equipment.

### **TITLE**

In the event the customer fails to pay as agreed in the purchase contract, Murzan, Inc. shall have the right to immediate possession of the property the premises where the property may be located and remove same

### **ASSIGNABILITY**

The customer may not assign any of its rights or obligations under the order without the prior express written consent of Murzan, Inc.

### **WARRANTY**

Murzan warrants to the original purchaser that equipment of Murzan manufacturing is free from defects in material and workmanship for a period of one (1) year from date of shipment.

Murzan guarantees to repair or replace F.O.B. Murzan, Inc., any such equipment found to be defective, provided written notice of the alleged defect is received within one year from date of shipment.

EXCLUDED FROM THE FOREGOING GUARANTEE ARE DAMAGES CAUSED BY ORDINARY WEAR AND TEAR, EROSION AND CORROSION, OR BY MISUSE, ABUSE OR IMPROPER HANDLING BY THE PURCHASER OR ANY THIRD PARTY.

MURZAN, INC. MAKES NO ADDITIONAL WARRANTIES, EXPRESSED OR IMPLIED, WHETHER OF MERCHANTABILITY, FITNESS FOR PURPOSE, OR OTHERWISE, OTHER THAN THAT STATED ABOVE. MURZAN, INC. SHALL NOT BE RESPONSIBLE FOR ANY INDIRECT SPECIAL OR CONSEQUENTIAL DAMAGES, NOR FOR ANY OTHER CLAIMS ARISING OUT OF THE SALE OR USE OF ITS EQUIPMENT, BEYOND THE REMEDY STATED ABOVE.

Equipment, parts or accessories manufactured by others carry the guarantee of the manufacturer only. Any warranties or claims which differ from the foregoing are unauthorized by Murzan, Inc. and become the warranty safety of the party making them, unless specifically authorized in writing by an officer of Murzan, Inc.

Should any provision of the foregoing be held ineffective, the remaining provisions shall continue in full force and effect.

### **EXCLUSIONS AND OPTIONS**

Installation, rigging, mounting, erection, electrical and pneumatic installation, and startup are not included unless specifically stated otherwise in the quotation.

Supervisory assistance is available for installation, erection, or startup at current Murzan, Inc. rates, plus all travel and living expenses.

### **RISK OF LOSS**

Murzan, Inc. shall not be liable for damages arising from its failure to make or delay in making delivery because of fire, flood, strikes, riots, embargoes on freight of any government, accidents, insurrections, lockouts, breakdown of machinery, loss or damage of goods in transit, Acts of God, or any other circumstances or unavoidable cause beyond the control of Murzan, Inc. In no case shall Murzan, Inc. be responsible for any liability, loss or damage after delivery of the equipment in good order and condition to the carrier or carriers at any point of shipment.

### **GENERAL**

These terms and conditions of sale cannot be supplemented or altered by any language contained in any purchase order or other customer's document unless accepted in writing by Murzan, Inc.

The sale shall be governed by, constructed and interpreted in accordance with, the laws of the State of Georgia, USA, and the buyer hereby submits to the non-exclusive jurisdiction of the courts of Georgia., and waives any objection due to the lack of jurisdiction.

## **10.0 ADDITIONAL DOCUMENTS**

Additional documents for your Murzan pump are attached.

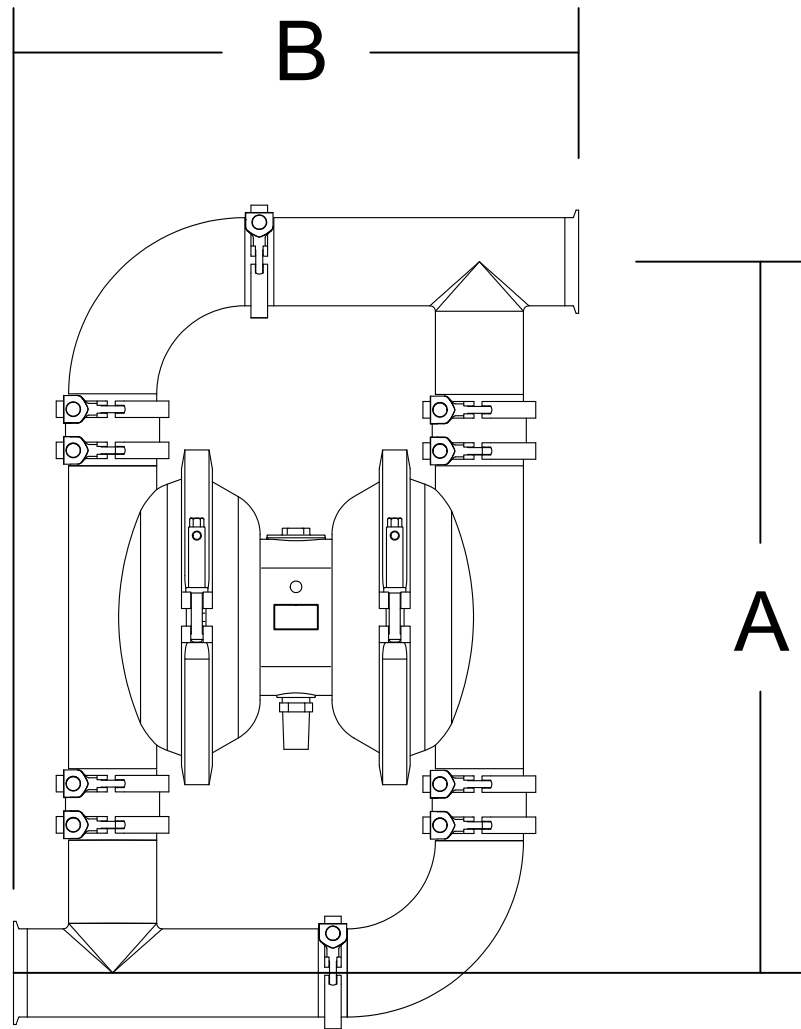

<b>A</b>	30.2 " (766 mm)
<b>B</b>	21.1 " (537 mm)

NOTE: YOUR MURZAN PUMP MAY HAVE DIFFERENT CHECK VALVES AND/OR DIFFERENT SIZE MANIFOLDS. HOWEVER, DIMENSIONS SHOWN ABOVE REMAIN SPECIFIC TO YOUR PUMP.

PROPRIETARY INFORMATION  
 THIS DOCUMENT IS THE PROPERTY OF MURZAN, INCORPORATED. THE INFORMATION CONTAINED HEREIN IS CONFIDENTIAL AND PRESENTED TO SAID CUSTOMER FOR REVIEW OR APPROVAL. UNDER NO CIRCUMSTANCES SHOULD THIS DOCUMENT BE REPRODUCED OR LOANED TO ANY THIRD PARTY WITHOUT THE WRITTEN PERMISSION OF MURZAN, INCORPORATED

NOTES:  
 1. THIS DRAWING IS FOR REFERENCE ONLY.

REV	DESCRIPTION	DATE	BY	APP

DATE: 31MAY17  
 CREATED BY: MKHOURY

DESCRIPTION:  
 MxM PUMP DIMENSIONS

DRAWING No. PL10043A

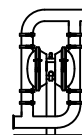

**MURZAN INC.**  
 2909 LANGFORD RD. 1-700  
 NORCROSS, GA. 30071 USA  
 TEL: (770) 448-0583 FAX: (770) 448-0967

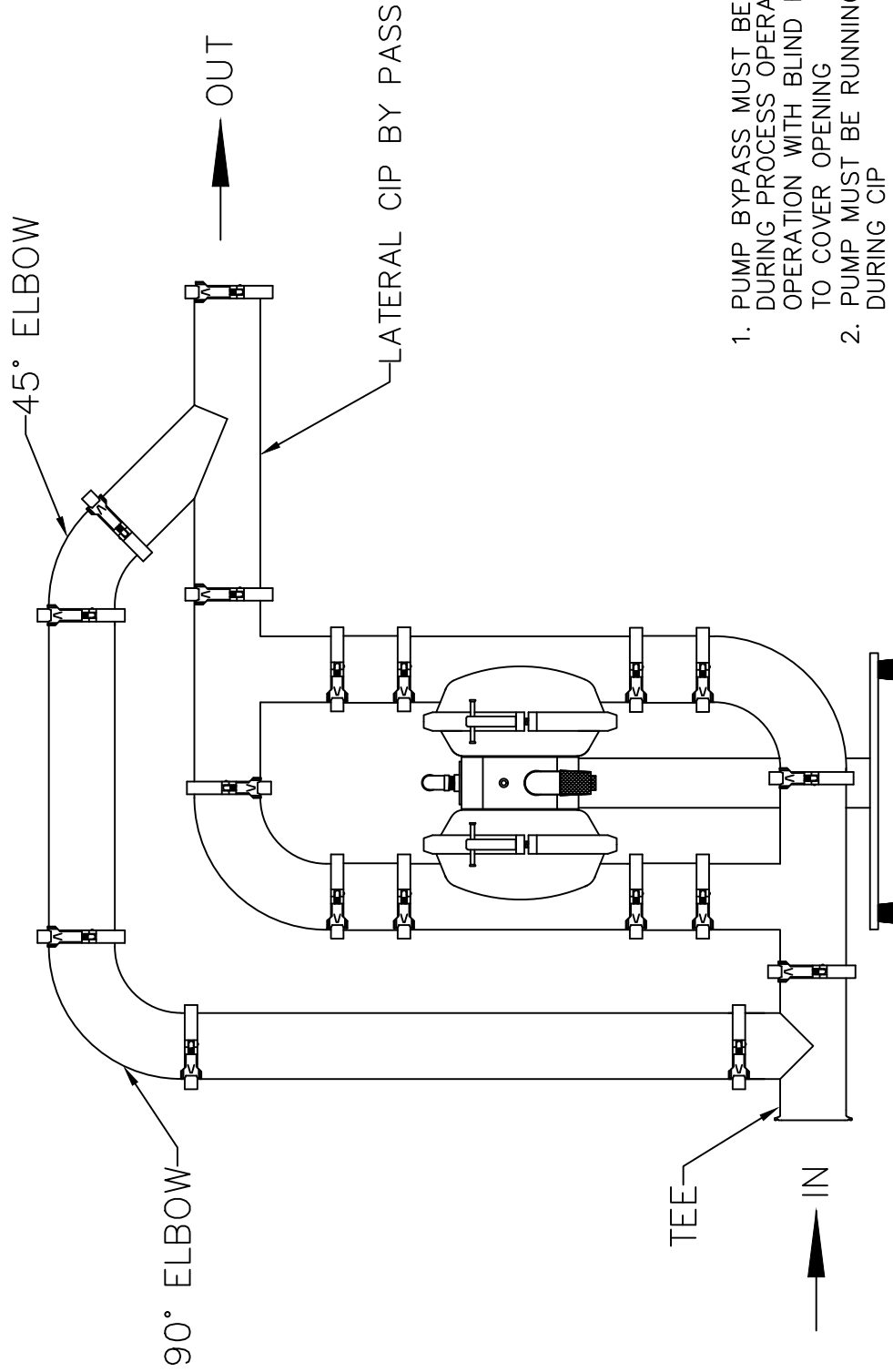

1. PUMP BYPASS MUST BE REMOVED DURING PROCESS OPERATION OPERATION WITH BLIND FLANGE TO COVER OPENING
2. PUMP MUST BE RUNNING DURING CIP

NOTES:

PROPRIETARY INFORMATION  
 THIS DOCUMENT IS THE PROPERTY OF MURZAN, INCORPORATED. THE INFORMATION CONTAINED HEREIN IS CONFIDENTIAL AND PRESENTED TO SAID CUSTOMER FOR REVIEW OR APPROVAL UNDER NO CIRCUMSTANCES SHOULD THIS DOCUMENT BE REPRODUCED OR LOANED TO ANY THIRD PARTY WITHOUT THE WRITTEN PERMISSION OF MURZAN, INCORPORATED

DRAWN BY: JUN CHEN  
 CHECKED BY: LU  
 DATE: 05JUNE99  
 SCALE: NONE

DESCRIPTION: PUMP CIP BYPASS SETUP  
 DRAWING NO. PL10036A

REV	DESCRIPTION	DATE	JUN	BY	LU	APP
-	NEW DRAWING	05JUNE99				

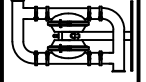

**MURZAN INC.**  
 2909 LANGFORD RD, 1-700  
 NORCROSS, GA. 30071 USA  
 TEL: (770) 448-0583 FAX: (770) 448-0967

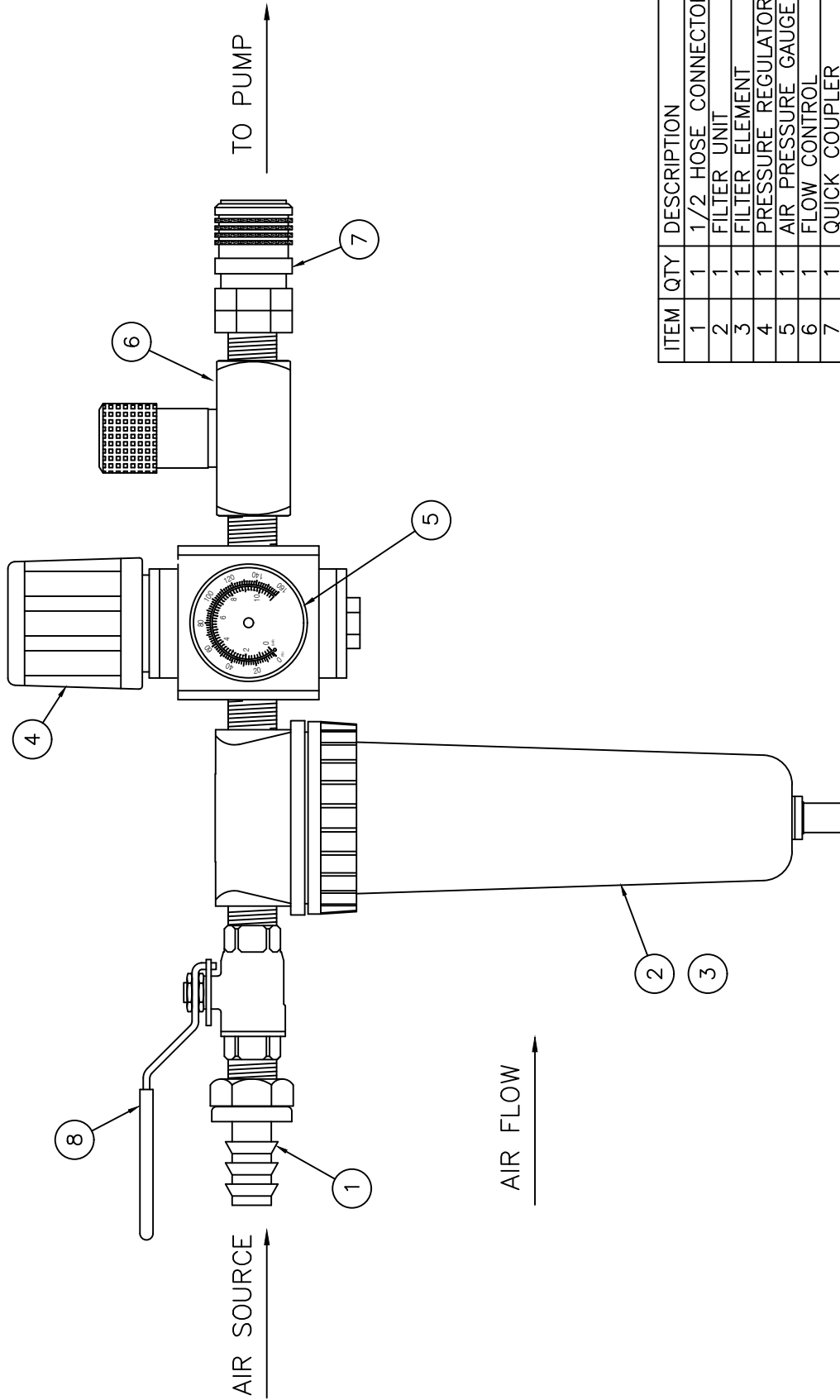

ITEM	QTY	DESCRIPTION
1	1	1/2 HOSE CONNECTOR
2	1	FILTER UNIT
3	1	FILTER ELEMENT
4	1	PRESSURE REGULATOR
5	1	AIR PRESSURE GAUGE
6	1	FLOW CONTROL
7	1	QUICK COUPLER
8	1	ON/OFF VALVE (NOT SUPPLIED)

NOTES:  
1. THIS DRAWING IS FOR REVIEW ONLY.

REV	DESCRIPTION	DATE	BY	APP
C	ADDED RECOMMENDED ON/OFF VALVE	07NOV99	JC	LU
B	CHANGED FLOW CONTROL	22OCT99	JC	LU
A	CLEARIFIED FLOW CONTROL DIRECTION	09FEB99	JC	TD

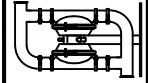

**MURZAN INC.**  
2909 LANGFORD RD. 1-700  
NORCROSS, GA. 30071 USA  
TEL: (770) 448-0583 FAX: (770) 448-0967

**PROPRIETARY INFORMATION**  
THIS DOCUMENT IS THE PROPERTY OF MURZAN, INCORPORATED. THE INFORMATION CONTAINED HEREIN IS CONFIDENTIAL AND PRESENTED TO SAID CUSTOMER FOR REVIEW OR APPROVAL. UNDER NO CIRCUMSTANCES SHOULD THIS DOCUMENT BE REPRODUCED OR LOANED TO ANY THIRD PARTY WITHOUT THE WRITTEN PERMISSION OF MURZAN, INCORPORATED

DESCRIPTION: MURZAN ASSEMBLY 'E' (STAGE ONE)

DRAWING NO. PL10038A

DRAWN BY:	G. DELCONTE
CHECKED BY:	T. DELOACH
DATE:	28SEP98
SCALE:	NONE