

Generalità:

I motori sincroni a magneti permanenti della serie LTS sono stati studiati e costruiti appositamente per soddisfare le esigenze di motorizzazioni moderne che prevedono l'azionamento diretto del "carico" senza l'utilizzo di sistemi meccanici aggiuntivi quali riduttori, cinghie-pulegge, rinvi.

Il concetto è molto semplice, applicare la coppia generata dal motore elettrico direttamente dove è richiesta, all'albero della macchina.

In particolare questi nuovi motori, pur essendo notevolmente compatti, consentono di ottenere coppie specifiche elevate, precisione di velocità e posizione, estrema silenziosità di funzionamento e risultano perfettamente integrabili nella struttura della macchina. Il raffreddamento a liquido della struttura esterna del motore garantisce una dissipazione ottimale delle perdite consentendo prestazioni costanti indipendenti dalla temperatura e dalla qualità dell'aria dell'ambiente di installazione.

Vantaggi dei motori LTS Sincrovert®:

- Elevata coppia resa all'albero
- Albero cavo con foro passante
- Elevata precisione di rotazione
- Assenza di manutenzione
- Controllo di coppia particolarmente accurato
- Utilizzabile in condizioni ambientali aggressive
- Elevata silenziosità di funzionamento
- Rendimento elevato
- Riduzione dei componenti necessari per realizzare il sistema cinematico
- Riduzione dell'elasticità e dei giochi tipici dei sistemi di trasmissione convenzionali
- Eliminazione delle perdite da attrito tipiche degli organi di trasmissione

Settori di utilizzo:

I principali settori che utilizzano questa serie di motori sono:

- Alimentare
- Meccanico e lavorazione metalli
- Lavorazione plastica
- Tessile
- Siderurgico
- Stampa
- Energia

Campi di impiego tipici:

- Estrusori per plastica, gomma e alimenti
- Lavorazione metalli
- Macchine iniezione materie plastiche
- Linee di produzione carta e cartone
- Macchine utensili e accessori di lavorazione
- Macchine da stampa
- Mescolatori
- Posizionatori
- Sistemi di collaudo trasmissioni
- Generazione di potenza

General information

The permanent magnets synchronous motors of the LTS series have been developed and made to specifically meet the requirements of modern motorization where the "load" is driven directly by the motor without any additional mechanical equipment such as reducers, belts and pulley, or countershafts.

The concept is extremely simple - to apply the torque generated by the electric motor directly where it is required; on the shaft of the machine.

In particular, these new motors, despite the fact that they are very compact, offer very high torque, speed and positioning precision, producing very little noise when running, and they can be integrated perfectly into the machine. The liquid cooling of the external structure of the motor guarantees an optimal dissipation of the losses and constant performance, regardless of the temperature and quality of the air in the environment.

Advantages of the LTS Sincrovert® motors:

- High torque output at shaft
- Hollow shaft with through hole
- High precision rotation
- Maintenance free
- Particularly precise torque control
- Can be used in aggressive environmental conditions
- Very quiet
- High efficiency
- Minimum number of components in the kinematic system
- Reduced elasticity and play typically found in conventional transmission systems.
- No transmission friction losses

Sectors of use:

The main sectors of use for this series of motors are:

- Foodstuffs
- Mechanical and metalwork
- Working plastics
- Textiles
- Iron and steel
- Print works
- Energy

Typical fields of use:

- Plastic, rubber and foodstuffs extruders
- Metalworking machines
- Plastic injection machines
- Paper and cardboard production lines
- Machine tools and accessories
- Printing machines
- Mixers
- Positioners
- Transmission testing systems
- Power generation

Allgemein:

Die Permanentmagnet-Synchronmotoren der Baureihe LTS wurden speziell für die Bedürfnisse moderner Motorisierung, bei der die „Last“ direkt, ohne zusätzliche mechanische Systeme (wie Untersetzungsgetriebe, Riemen-Riemenscheibe, Vorgelege) bewegt werden muss, entwickelt und gebaut.

Das Konzept ist denkbar einfach: Das vom Elektromotor erzeugte Drehmoment direkt dort anlegen, wo es gebraucht wird, an der Maschinenwelle.

Insbesondere ermöglichen diese neuen Motoren, obwohl sie äußerst kompakt sind, hohe spezifische Drehmomente, Drehzahl- und Positionsgenauigkeit sowie einen extrem ruhigen Lauf und sind perfekt in die Maschinenkonstruktion integrierbar. Die Flüssigkeitskühlung der Motoraußenkonstruktion gewährleistet, dass Verluste optimal abgeführt werden, und ermöglicht von der Umgebungstemperatur und der Luftqualität der Installationsumgebung unabhängige konstante Leistungen.

Vorteile der Motoren LTS Sincrovert®:

- Hohes Drehmoment für die Antriebswelle
- Hohlwelle mit Durchgangsbohrung
- Hohe Rundlaufgenauigkeit
- Wartungsfrei
- Besonders präzise Drehmomentsteuerung
- Unter aggressiven Umgebungsbedingungen einsetzbar
- Sehr ruhiger Lauf
- Hoher Leistungsgrad
- Weniger Bauteile für das kinematische System erforderlich
- Verringerung der für herkömmliche Antriebssysteme typischen Elastizität und Spiele

Einsatzbranchen:

Diese Motorbaureihe wird hauptsächlich in folgenden Branchen eingesetzt:

- Lebensmittelbranche
- Maschinenbau und Metallbearbeitung
- Kunststoffbearbeitung
- Textilbranche
- Eisen- und Stahlindustrie
- Druck
- Energie

Typische Einsatzbereiche:

- Extruder für Kunststoff, Gummi und Lebensmittel
- Metallbearbeitung
- Maschinen für Kunststoffeinspritzung
- Papier- und Kartonerfertigungslinien
- Werkzeugmaschinen und Bearbeitungszubehör
- Druckmaschinen
- Rührwerke
- Stellwerke
- Antriebsprüfsysteme
- Stromerzeugung

LTS - SINCROVERT®

120...14.000 Nm



Motore COPPIA sincrono raffreddato a liquido
Liquid cooled synchronous TORQUE motor
 TORQUE-Motor wassergekühlt

Motore	<i>Motor</i>	Motor	AC 3-phase synchronous liquid cooled torque motor
Esecuzione	<i>Execution</i>	Ausführung	Liquid cooled permanent magnets torque motors
Altezze d'asse	<i>Shaft height</i>	Wellenhöhe	132, 160, 200, 280, 355mm
Potenza	<i>Power</i>	Leistung	2,5...496kW
Coppia	<i>Torque</i>	Drehmoment	118...14.046Nm
Peso	<i>Weight</i>	Gewicht	73...2020kg
Nr. di poli	<i>Nr. of poles</i>	Anzahl Pole	16, 24, 36
Velocità base	<i>Base speed</i>	Nenndrehzahl	100, 150, 200, 250, 300, 350, 400, 500, 600rpm
Tensione di alimentazione	<i>Supply voltage</i>	Versorgungsspannung	330...400Vac
Collegamento	<i>Connection</i>	Anschluss	Star
Collegamenti elettrici	<i>Electrical connection</i>	Elektrischer Anschluss	Nr.3 or 6 terminals, (star or double star connection)
Classe di isolamento	<i>Insulation class</i>	Isolationklasse	F, temperature rise cl.F
Termoprotettori	<i>Thermal protectors</i>	Thermikschutz	PTO (klixon) as standard, PTC*, KTY84-130*, PT100* on request
Forma costruttiva	<i>Mounting construction</i>	Bauform	B3, B35 + hollow through shaft
Grado di protezione	<i>Protection degree</i>	Schutzart	IP 54, IP 55*
Tipo di raffreddamento	<i>Type of cooling</i>	Art der Kühlung	IC 9W7
Grado di vibrazione	<i>Vibration degree</i>	Vibrationsgrad	R
Metodo di equilibratura	<i>Balancing method</i>	Auswuchtmethode	Without keyway
Temperatura ambiente	<i>Ambient temperature</i>	Raumtemperatur	-20...+60°C
Temperatura liquido	<i>Liquid temperature</i>	Kühlmittel Temperatur	+20°C (reference temp.), up to + 60°C with power derating
Tipo di liquido	<i>Liquid type</i>	Kühlmittel Typ	Water + antifreezing and anticorrosion additives
Colore	<i>Color</i>	Farbe	RAL 5009 (medium blue)
Materiale carcassa	<i>Frame material</i>	Statormaterial	Steel
Materiale coperchi	<i>Covers material</i>	Deckelmaterial	Cast iron
Materiale flangia	<i>Flange material</i>	Flanschmaterial	Cast iron
Albero	<i>Shaft</i>	Welle	Steel C45 – 39NiCrMo on request
Posizione morsettiera	<i>Terminal box position</i>	Deckelmaterial	Standard position top-side mounted,
Collegamento encoder	<i>Encoder connection</i>	Drehgeber Anschluss	With pulley+belt transmission for hollow through shaft version, axial in line connection for cylindrical or splined shaft version.
Opzioni disponibili	<i>Options available</i>	Mögliche Optionen	Absolute encoder, PTC, KTY84-130, PT100, space heaters, cylindrical or splined solid shaft,
Disponibilità	<i>Availability</i>	Verfügbarkeit	Made on request
Tempo di consegna	<i>Delivery time</i>	Lieferzeit	From 6 up to 12 weeks size and options depending.

* A richiesta con sovrapprezzo – On request with price increase –

DATI GENERALI	GENERAL DATA	ALLGEMEINE DATEN	
Protezione motore	Motor Protection	Schutzart	IP 55
Isolamento	Insulation	Isolation	classe F – F class – F Klasse
Protezione termica	Thermal Protection	Thermikschutz	PTO (Klixon) – PTC ²⁾ – PT100 ²⁾ – KTY84-130 ²⁾
Rumore L _w	Noise L _w	Geräuschpegel L _w	L _w < 73 dB (A)
Raffreddamento	Cooling System	Kühlung	IC 9W7
Sollecitazione massima	Max adm. shock	Max schuss	V eff 6 mm/s (f = 6,3...63Hz) – acc. 4.0 m/s ² (f > 63Hz)
Installazione	Ambient	Umgebungstem.	- 20 / + 40°C – 1000 m ASL

RAFFREDDAMENTO	COOLING	KÜHLUNG						
Grandezza motore	Motor size	MotorBaugröße	Size	132	160	200	280	355
Portata liquido	Liquid delivery	Durchflußmenge	l/min	8	10	14	20	30
Capacità di raffreddamento	Cooling capacity	Kühlleistung	kW	max 15 % of P _n				
Pressione massima	Max perm. pressure	Max. Druck	Bar	3	3	3	3	3
Caduta di pressione max.	Max pressure drop	Maximaler Druckbfall	Bar	< 0.5	< 0.6	< 0.8	< 0.8	< 1
Temperatura liquido *	Coolant temperature *	Kühlmittel-Temperatur *	18°C (min. 16°C) in funzionamento nominale - at rated operation					
Qualità liquido	Type of coolant	Kühlmittel	Acqua + anticorrosivi/antigelo Water + anticorrosion/no-frost additives (max 20%)					
Circuito di raffreddamento	Cooling circuit	Kühlkreislauf	Chiuso con scambiatore di calore esterno - Closed with external heat-exchanger					

* in ingresso – input temperature - Eintrittstemperatur , Vedere sez. A par. 2.3 e 5.3 - See sec. A par. 2.3 and 5.3 - Siehe Seite A Abschnitt 2.3 und 5.3

TRASDUTTORE	TRANSDUCER	MEßWANDLER	
Encoder tipo	Encoder type	Drehgeber typ	Absolute single-turn - SinCos Hiperface
Segnale	Signal	Signal	1024 sinus/turn 1V p/p – supply 7...12Vdc
Rapporto encoder ³⁾	Encoder ratio ³⁾	Uebersetzung Drehgeber ³⁾	ratio 4:1 for hollow shaft motors (3:1 only for LTS 355)

LIMITI DI VELOCITA'	SPEED LIMITS	DREHZAHLGRENZE						
Grandezza motore	Motor size	MotorBaugröße	Size	132	160	200	280	355
Velocità max meccanica	Max mechanical speed	Max. mechanische Drehzahl	rpm	1000	900	600	550	500

DATI ELETTRICI E PRESTAZIONI		ELECTRICAL DATA AND PERFORMANCES						ELEKTRISCHE DATEN UND LEISTUNGEN								
Motor Type	n _n 200 rpm U _n 330V		n _n 300 rpm U _n 330V		n _n 400 rpm U _n 330V		n _n 500 rpm U _n 330V		n _n 600 rpm U _n 330V		n _n 700 rpm U _n 330V		M _{pk} Nm	M _{low} Nm	M ₀ Nm	poles nr
	M _n Nm P _n Kw	I _n A I _{pk} A	M _n Nm P _n Kw	I _n A I _{pk} A	M _n Nm P _n Kw	I _n A I _{pk} A	M _n Nm P _n Kw	I _n A I _{pk} A	M _n Nm P _n Kw	I _n A I _{pk} A	M _n Nm P _n Kw	I _n A I _{pk} A				
M _{low}	Coppia continuativa disponibile a bassa velocità						Continuous torque available at low speed						Dauerdrehmoment bei niedriger Drehzahl			
M _{pk}	Coppia max erogabile dal motore						Maximum output motor torque						Max. Abgabemoment des Motors			
M ₀	Coppia continuativa disponibile a rotore bloccato						Continuous torque available at blocked rotor						Stillstandsmoment mit blockiertem Rotor			
nr	nr. di poli del motore						motor poles						Polzahl			
n _n	Velocità di rotazione nominale						Nominal speed						Nenndrehzahl			
M _n	Coppia nominale resa all'albero						Nominal torque at the shaft						Nenndrehmoment an der Welle			
P _n	Potenza meccanica nominale resa all'albero						Nominal mechanical power at the shaft						Mechanische Nennleistung an der Welle			
V _n	Tensione nominale del motore						Motor nominal voltage						Nennspannung			
I _n	Corrente nominale						Nominal current						Nennstrom			
I _{pk}	Corrente massima di picco						Max peak current						max. möglicher Spitzenstrom des Motors			

TORQUE DIAGRAM

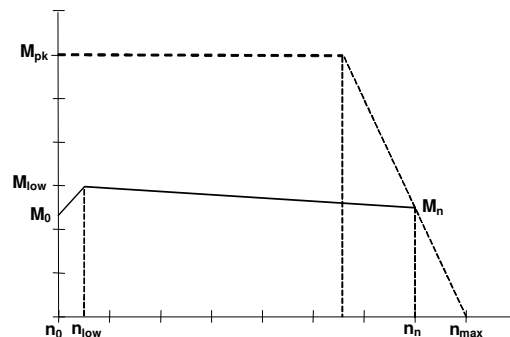

²⁾ Opzione disponibile a richiesta – Option available on request – Verfügbares Sonderzubehör

Note 3) Mechanical ratio between the encoder and the motor shaft made with pulley and belt (ie. 4:1.....4 rev. Encoder = 1 rev. Motor shaft). For motors without the through hollow shaft the encoder is installed axially (direct without the transmission ratio).

Motor Type	DATI ELETTRICI E PRESTAZIONI				ELECTRICAL DATA AND PERFORMANCES				ELEKTRISCHE DATEN UND LEISTUNGEN							
	n _n 200 rpm U _n 330V		n _n 300 rpm U _n 330V		n _n 400 rpm U _n 330V		n _n 500 rpm U _n 330V		n _n 600 rpm U _n 330V		n _n 700 rpm U _n 330V		M _{pk} Nm	M _{low} Nm	M ₀ Nm	poles nr
	M _n Nm P _n Kw	I _n A I _{pk} A	M _n Nm P _n Kw	I _n A I _{pk} A	M _n Nm P _n Kw	I _n A I _{pk} A	M _n Nm P _n Kw	I _n A I _{pk} A	M _n Nm P _n Kw	I _n A I _{pk} A	M _n Nm P _n Kw	I _n A I _{pk} A				
LTS																
132 S	118 2,5	6,3 11,4	118 3,7	9,2 16,6	118 4,9	11,6 21,0	117 6,1	14,2 25,9	116 7,3	16,5 30,4	114 8,4	18,7 35,0	215	120	96	
132 M	177 3,7	9,4 17,0	177 5,6	13,7 24,8	176 7,4	17,3 31,5	176 9,2	21,3 38,9	174 10,9	24,7 45,6	171 12,5	28,1 52,6	320	180	144	
132 L	236 5,0	12,6 22,7	236 7,4	18,3 33,1	235 9,9	23,1 42,0	234 12,3	28,4 51,9	232 14,6	33,0 60,8	228 16,7	37,4 70,1	425	240	192	16
132 P	296 6,2	15,7 28,4	296 9,3	22,9 41,4	294 12,3	28,9 52,5	293 15,3	35,5 64,8	290 18,2	41,2 76,0	285 20,9	46,8 87,6	535	300	240	
132 X	355 7,4	18,9 34,1	355 11,1	27,5 49,7	353 14,8	34,7 63,0	351 18,4	42,6 77,8	347 21,8	49,4 91,2	342 25,1	56,1 105	640	360	288	
160 S	359 7,5	18,5 33,4	359 11,3	26,0 47,0	358 15,0	32,5 59,0	356 18,6	39,5 72,1	352 22,1	46,3 85,5	347 25,4	53,2 99,7	650	365	255	
160 M	449 9,4	23,1 41,8	449 14,1	32,5 58,8	447 18,7	40,6 73,7	445 23,3	49,3 90,1	440 27,6	57,9 106,8	433 31,8	66,5 125	810	456	319	16
160 L	539 11,3	27,8 50,1	539 16,9	39,0 70,5	536 22,5	48,7 88,5	534 27,9	59,2 108	528 33,2	69,5 128	520 38,1	79,8 150	975	547	383	
160 P	629 13,2	32,4 58,5	629 19,8	45,5 82,3	626 26,2	56,8 103,2	622 32,6	69,1 126	616 38,7	81,1 150	606 44,5	93,1 175	1135	638	447	
LTS																
Motor Type	n _n 100 rpm U _n 330V		n _n 150 rpm U _n 330V		n _n 200 rpm U _n 330V		n _n 250 rpm U _n 330V		n _n 300 rpm U _n 330V		n _n 350 rpm U _n 330V		M _{pk} Nm	M _{low} Nm	M ₀ Nm	poles nr
	M _n Nm P _n Kw	I _n A I _{pk} A	M _n Nm P _n Kw	I _n A I _{pk} A	M _n Nm P _n Kw	I _n A I _{pk} A	M _n Nm P _n Kw	I _n A I _{pk} A	M _n Nm P _n Kw	I _n A I _{pk} A	M _n Nm P _n Kw	I _n A I _{pk} A				
200 S	682 7,1	18,1 32,8	679 10,7	25,4 46,1	675 14,1	32,0 58,5	672 17,6	38,9 71,4	665 20,9	45,2 83,8	658 24,1	52,1 97,7	1235	693	554	
200 M	910 9,5	24,2 43,7	905 14,2	33,8 61,4	900 18,9	42,7 78,0	896 23,5	51,9 95,2	887 27,9	60,2 112	877 32,2	69,5 130	1645	924	739	
200 L	1328 13,9	35,3 63,8	1321 20,7	49,4 89,7	1314 27,5	62,3 114	1307 34,2	75,7 139	1294 40,6	87,9 163	1280 46,9	101 190	2400	1348	1078	24
200 P	1770 18,5	47,1 85,0	1761 27,7	65,8 120	1752 36,7	83,1 152	1743 45,6	101 185	1725 54,2	117 217	1707 62,6	135 254	3200	1797	1438	
200 X	2213 23,2	58,8 106	2201 34,6	82,3 149	2190 45,9	104 190	2179 57,0	126 232	2157 67,7	146 272	2134 78,2	169 317	4000	2246	1797	
280 S	2092 21,9	47,9 84,2	2082 32,7	71,5 126	2071 43,4	91,7 163	2060 53,9	114 203	2039 64,1	134 242	2018 74,0	155 282	3675	2226	1781	
280 M	2511 26,3	57,5 101	2498 39,2	85,8 151	2485 52,0	110 195	2472 64,7	137 244	2447 76,9	161 290	2421 88,7	186 338	4410	2671	2137	
280 L	3347 35,1	76,7 135	3330 52,3	114 202	3313 69,4	147 260	3296 86,3	183 326	3262 102	214 386	3228 118	248 451	5880	3562	2849	
280 P	5021 52,6	115 202	4996 78,5	172 303	4970 104	220 391	4945 129	274 488	4894 154	322 580	4843 177	371 676	8820	5342	4274	24
280 X	6276 65,7	144 252	6245 98,1	215 379	6213 130	275 488	6181 162	342 610	6117 192	402 725	6053 222	464 845	11025	6678	5342	
355 S	9088 95,2	208 366	9042 142	311 548	8996 188	399 707	8950 234	496 884	8858 278	582 1049	8765 321	672 1224	15900	9227	7381	
355 M	9915 104	227 399	9864 155	339 598	9814 206	435 771	9764 256	541 964	9663 304	635 1144	9562 350	733 1335	17400	10066	8052	
355 L	11567 121	265 465	11508 181	395 698	11450 240	507 900	11391 298	631 1125	11273 354	741 1335	11156 409	855 1558	20300	11743	9395	36
355 P	12393 130	284 499	12330 194	424 748	12267 257	543 964	12205 319	676 1205	12079 379	794 1431	11953 438	917 1669	21750	12582	10066	
355 X	14046 147	322 565	13974 219	480 848	13903 291	616 1093	13832 362	766 1366	13689 430	900 1621	13547 496	1039 1892	24600	14260	11408	

La velocità max in deflussaggio è n_n * 1.5 con limite meccanico come da pagina precedente
The max field weakening speed is n_n * 1.5 with mechanical limit as indicated on above pag.

7.5 LTS

7.5 LTS

7.5 LTS

LTS
Versione ad albero cavo passante con foro di grande diametro

LTS
Version with big diameter through hollow shaft

LTS
Vollständiges Hohlwelle mit Loch mit großem Durchmesser

Motor type	Drive-end Bearing code (dim. mm)	Non drive-end Bearing code (dim. mm)	Max. radial load Fr - [N]	Max. axial load Fa - [N]
132	61924 (120x165x22)	61922 (110x150x20)	2500	1500
160	61838 (190x240x24)	61832 (160x200x20)	4000	1800
200	61838 (190x240x24)	61832 (160x200x20)	4000	1800
280	61864 (320x400x38)	61856 (280x350x33)	8000	2000
355	61880 (400x500x46)	61876 (380x480x46)	10000	2500

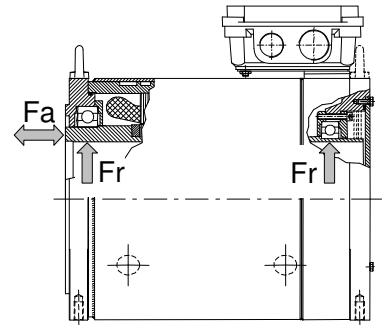

LTS

DISEGNO ESPLOSO - EXPLODED DRAWING - ESPLOSIONSZEICHNUNG

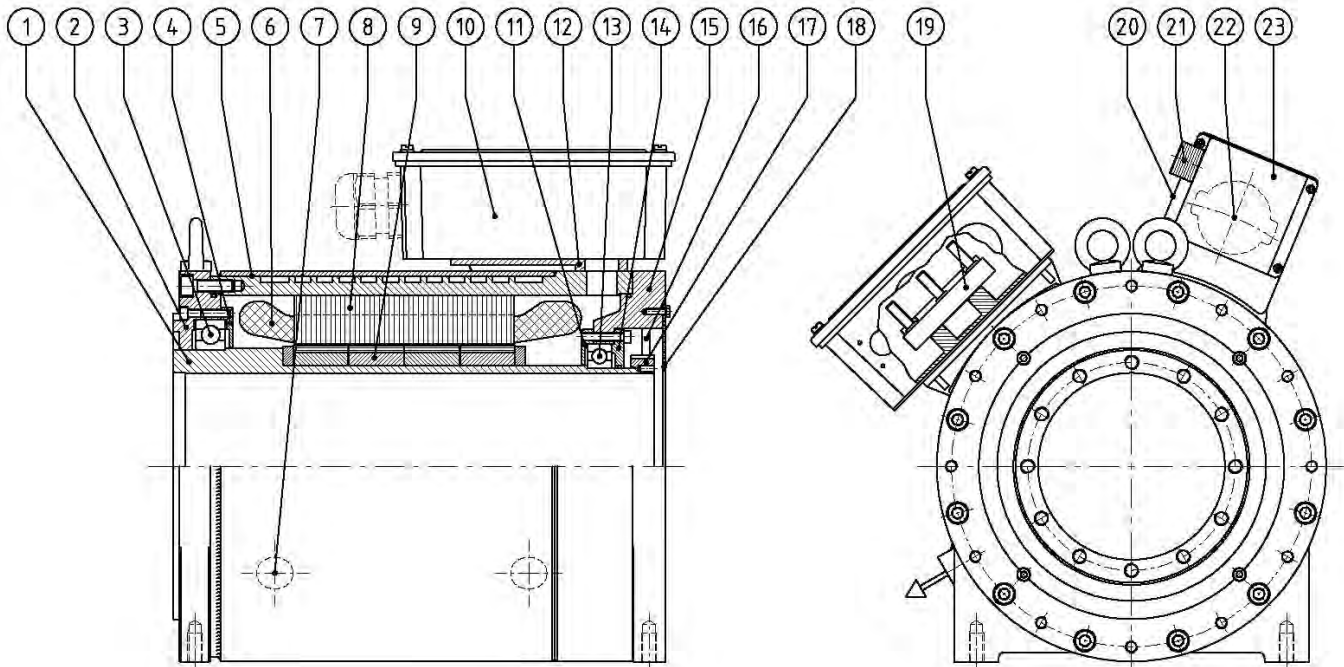

1	Albero	Shaft	13	Cuscinetto lato opposto comando	Non drive-end bearing
2	Coperchio lato comando	Drive-end cover	14	Flangia paragrasso	Grease Flange
3	Cuscinetto lato comando	Drive-end bearing	15	Coperchio lato opposto comando	Non drive-end cover
4	Flangia paragrasso	Grease Flange	16	Cinghia trasduttore	Transducer belt
5	Carcassa	Frame	17	Puleggia trasduttore	Transducer pulley
6	Avvolgimento	Winding	18	Coperchio puleggia	Pulley cover
7	Ingresso /uscita liquido refrigerante	In /out cooling liquid	19	Morsettiera	Terminal board
8	Statore	Stator	20	Supporto trasduttore	Transducer support
9	Rotore	Rotor	21	Connettore trasduttore	Transducer connector
10	Coperchio coprimorsettiera	Terminal box cover	22	Trasduttore	Transducer
11	Flangia paragrasso	Grease Flange	23	Coperchio trasduttore	Transducer cover
12	Portamorsettiera	Terminal box			

Disegno schematico per l'identificazione dei componenti principali del motore. Le esecuzioni speciali a richiesta e le opzioni non sono contemplate.

Schematic drawing to identify the main components of the motor. No special versions or options are shown here.

LTS 132

DIMENSIONI DI INGOMBRO - OVERALL DIMENSIONS - ABMESSUNGEN

Dimensions [mm]

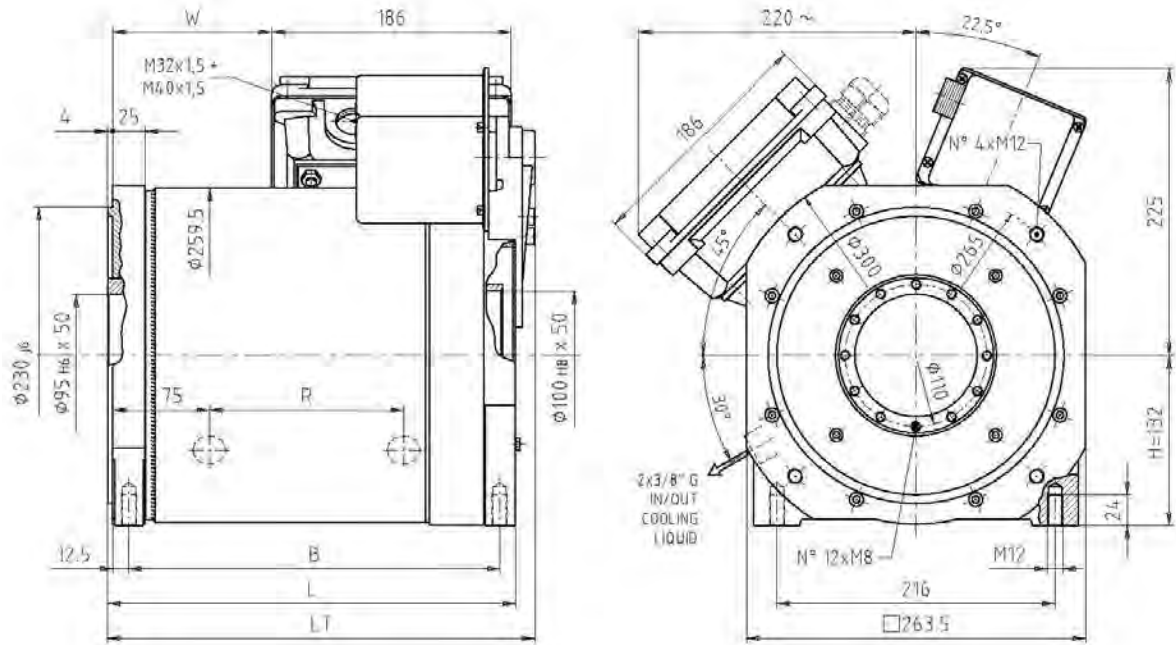

LTS	B	L	LT	R	W	inertia J (kgm ²)	weight (kg)
132S	243	272	290	106	78	0.054	75
132M	288	317	335	151	123	0.074	90
132L	333	362	380	196	168	0.095	110
132P	378	407	425	241	213	0.116	130
132X	423	452	470	286	258	0.136	145

LTS

LTS 160

DIMENSIONI DI INGOMBRO - OVERALL DIMENSIONS - ABMESSUNGEN

Dimensions [mm]

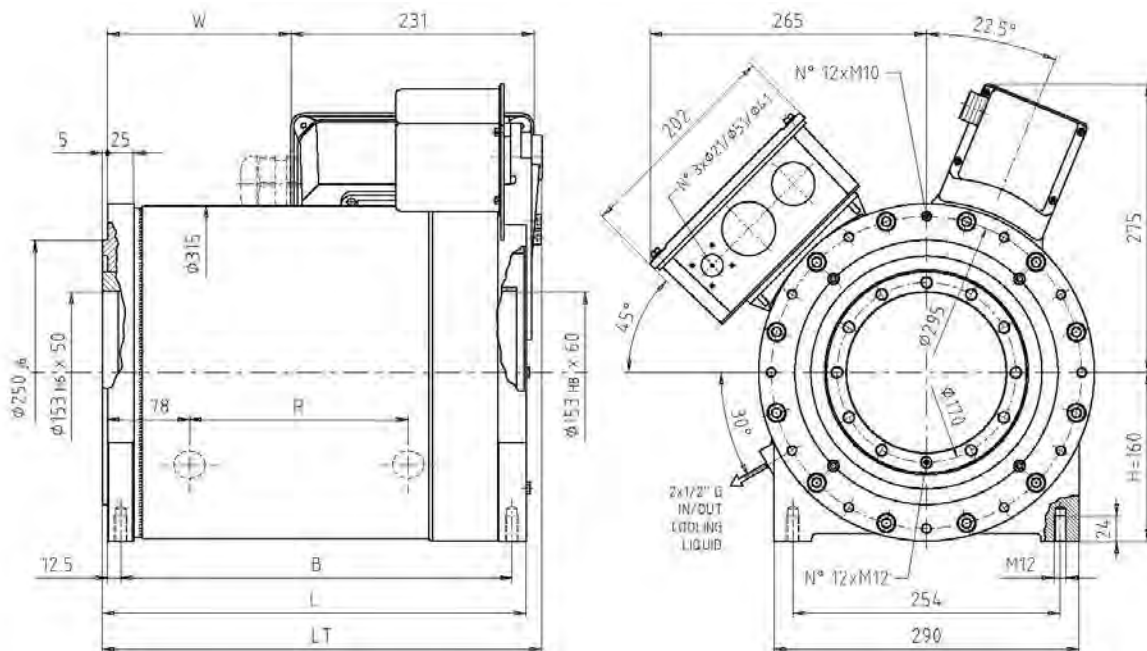

LTS	B	L	LT	R	W	inertia J (kgm ²)	weight (kg)
160S	372	405	420	208	174	0.21	150
160M	417	450	465	253	219	0.24	175
160L	462	495	510	298	264	0.28	200
160P	507	540	555	343	309	0.31	220

LTS 200

DIMENSIONI DI INGOMBRO - OVERALL DIMENSIONS - ABMESSUNGEN

Dimensions [mm]

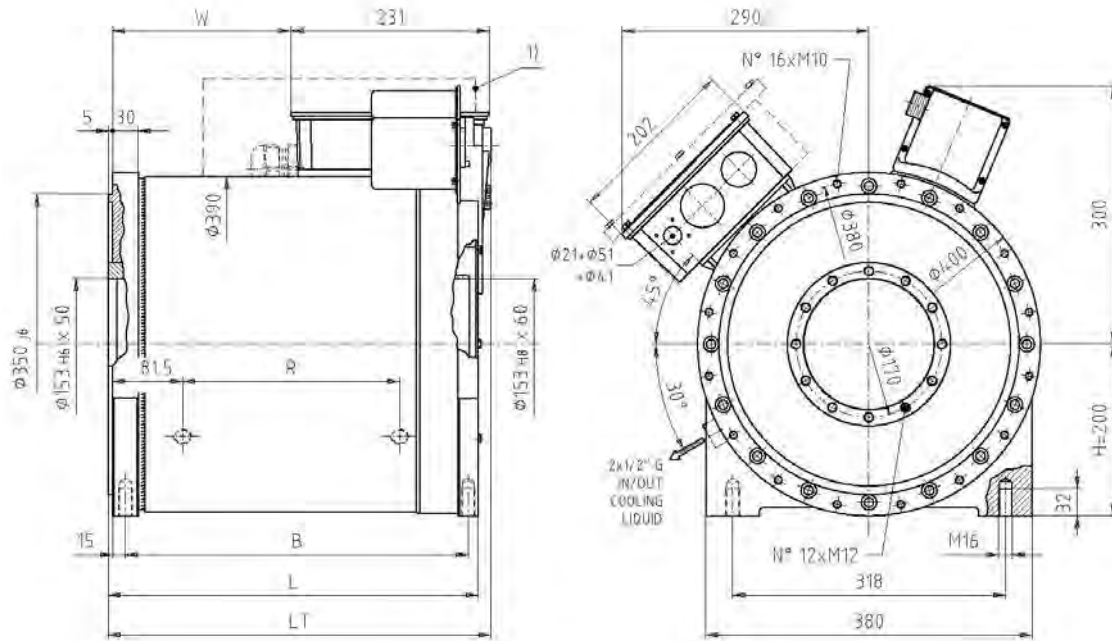

LTS	B	L	LT	R	W	inertia J (kgm ²)	weight (kg)
200S	264.5	296	311	118	73	0.62	185
200M	309.5	341	356	163	118	0.81	220
200L	399.5	431	446	253	208	1.2	300
200P	489.5	521	536	343	298	1.6	370
200X	579.5	611	626	433	388	1.9	450

LTS 280

DIMENSIONI DI INGOMBRO - OVERALL DIMENSIONS - ABMESSUNGEN

Dimensions [mm]

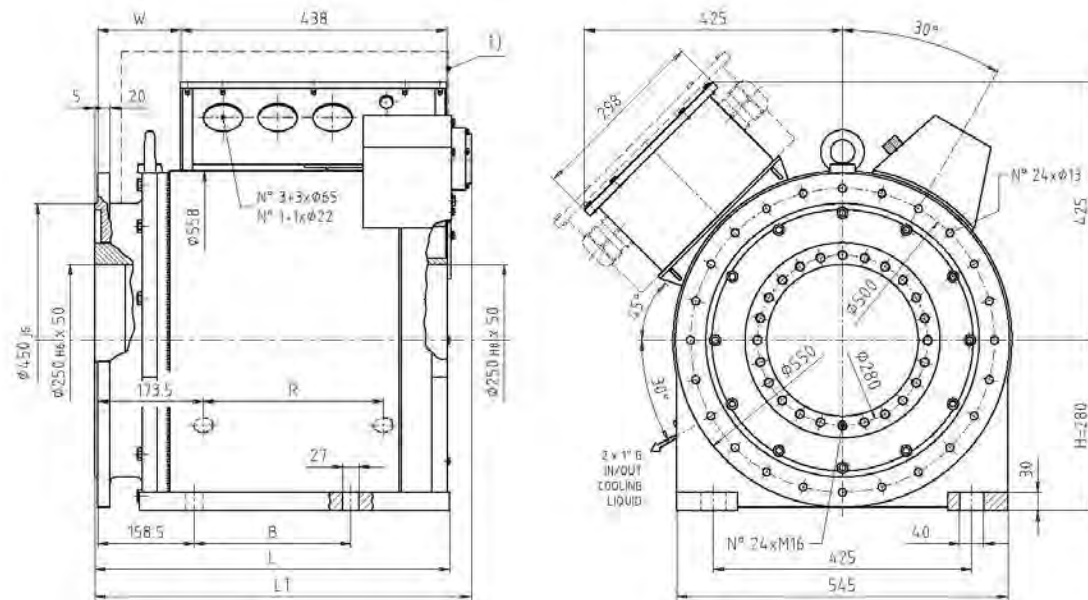

LTS	B	L	LT	R	W	inertia J (kgm ²)	weight (kg)
280S	213	539	575	251	91	4.1	560
280M	258	584	620	296	136	4.9	620
280L	348	674	710	386	226	5.6	750
280P	528	854	890	566	406	7.0	1020
280X	663	989	1025	701	541	9.9	1220

1) Scatola morsettiata maggiorata per corrente superiore a 300A - Increased size terminal box for current higher than 300A

LTS 355

DIMENSIONI DI INGOMBRO - OVERALL DIMENSIONS - ABMESSUNGEN

Dimensions [mm]

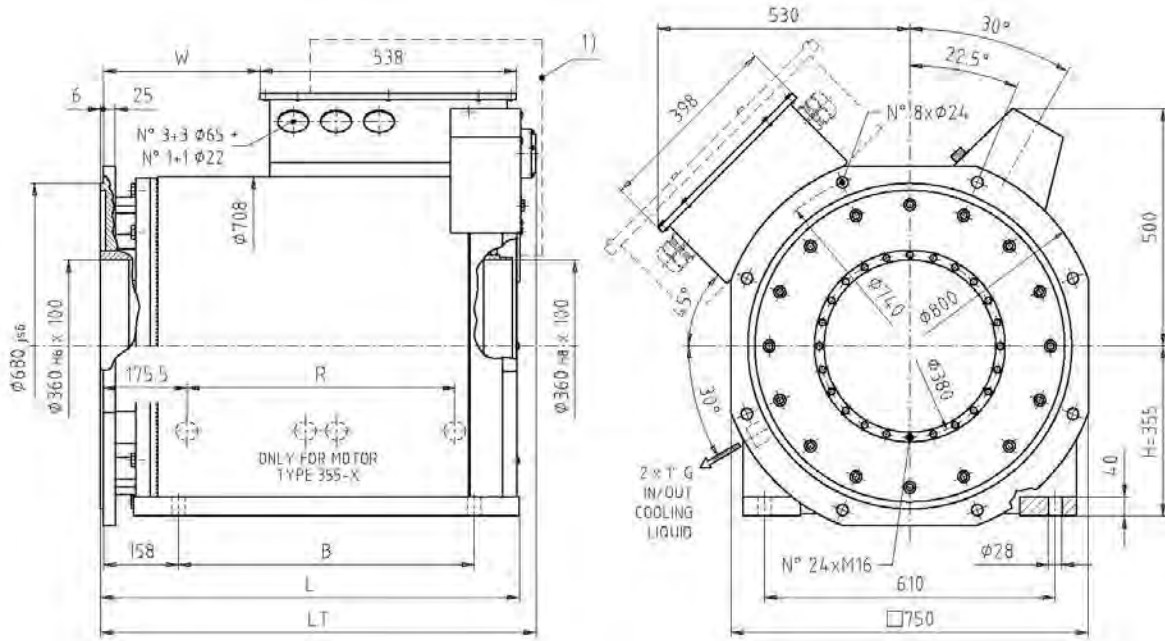

LTS	B	L	LT	R	W	inertia J (kgm ²)	weight (kg)
355S	575	835	870	517	284	27	1430
355M	620	880	915	562	329	30	1530
355L	710	970	1005	652	419	24	1730
355P	755	1015	1050	697	464	36	1830
355X	845	1105	1140	787	554	41	2030

1) Scatola morsettiata maggiorata per corrente superiore a 500A - Increased size terminal box for current higher than 500A

LTS

ESEMPI DI MONTAGGIO - MOUNTING EXAMPLES

EXPANSION ELEMENT + REACTION ARM

RIGID COUPLING + REACTION ARM

FEET MOUNTING + FLEXIBLE COUPLING

FLANGE MOUNTING + FLEXIBLE COUPLING

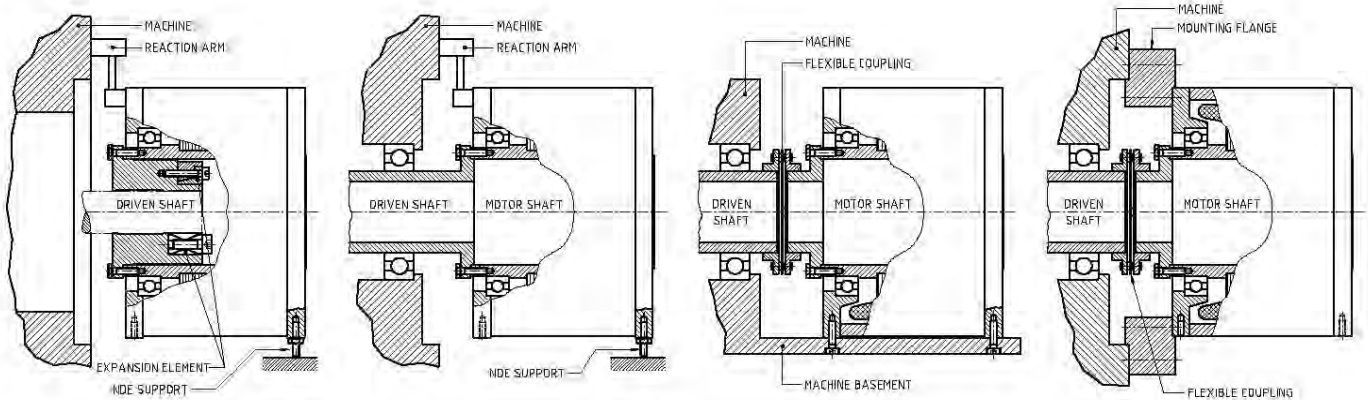

7.5 LTS

LTS-S
Versione con albero sporgente cilindrico con chiave, cilindrico liscio, scanalato.

7.5 LTS

LTS-S
Version with cylindrical shaft with key, without key, splined

7.5 LTS

LTS-S
Ausführung mit vorstehender Welle zylindrisch mit Keil, zylindrisch, glatt, gerillt.

CUSCINETTI

BEARINGS

WÄLZLAGER

Motor type	Drive-end Bearing code ⁵⁾	Non drive-end Bearing code ⁵⁾	Max. radial load Fr - [N]	Max. axial load Fa - [N]
132	* 1)	* 1)	* 1)	* 1)
160	* 1)	* 1)	* 1)	* 1)
200	6018	6018	3800	1800
280	61936 MA	61936 MA	7000	4000
355	6036 M	6036 M	14000	5000

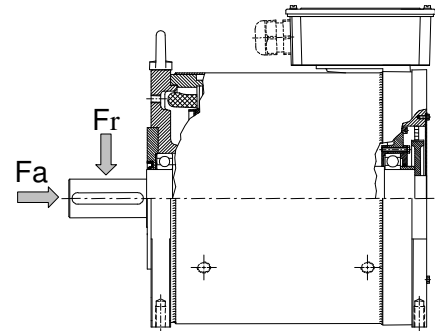

¹⁾ Dato non ancora disponibile, data not available yet

⁵⁾ Lubrificati a vita con grasso - Life lubricated with grease -

LTS-S

DISEGNO ESPLOSO - EXPLODED DRAWING - ESPLOSIONSZEICHNUNG

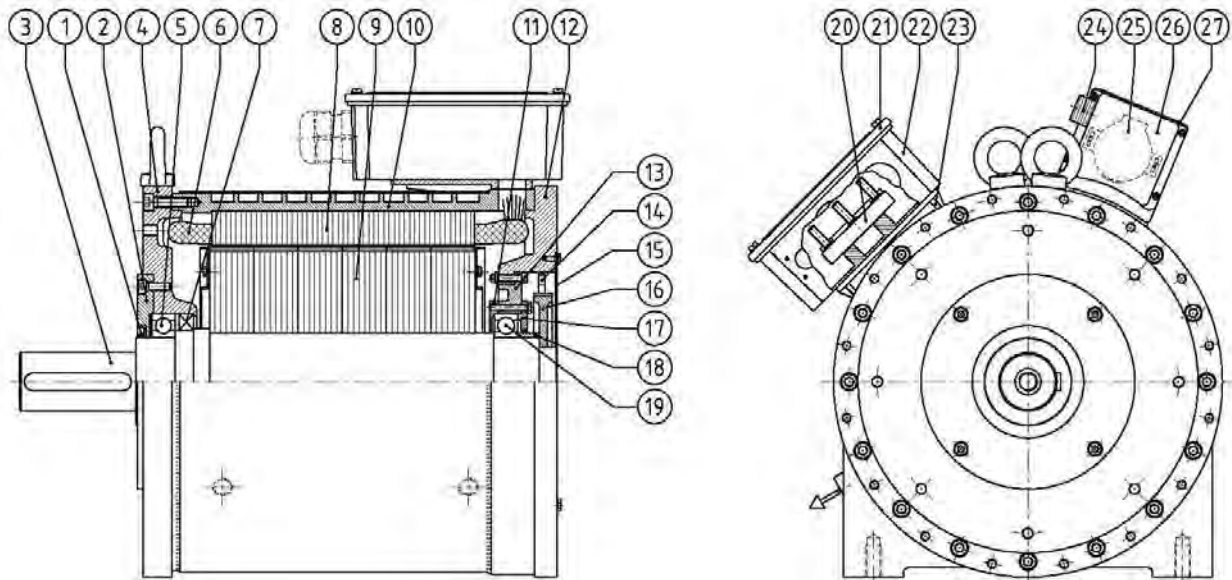

1	Anello di tenuta	Oil seal	15	Coperchio Puleggia	Pulley cover
2	Flangia paragrasso	Grease Flange	16	Puleggia trasduttore	Transducer pulley
3	Albero	Shaft	17	Flangia paragrasso	Grease Flange
4	Coperchio lato comando	Drive-end cover	18	Distanzile	Spacer
5	Cuscinetto lato comando	Drive-end bearing	19	Cuscinetto lato opposto comando	Non drive-end bearing
6	Avvolgimento	Winding	20	Morsettiera	Terminal board
7	Anello di tenuta	Oil seal	21	Coperchio coprimorsettiera	Terminal box cover
8	Statore	Stator	22	Portamorsettiera	Terminal box
9	Rotore	Rotor	23	Supporto coprimorsettiera	Terminal box support
10	Carcassa	Frame	24	Connettore Trasduttore	Transducer connector
11	Flangia paragrasso	Grease Flange	25	Trasduttore	Transducer
12	Coperchio lato opposto comando	Non drive-end cover	26	Coperchio trasduttore	Transducer cover
13	Mozzo supporto cuscinetto	Bearing support	27	Supporto trasduttore	Transducer support
14	Cinghia trasduttore	Transducer belt			

Disegno schematico per l'identificazione dei componenti principali del motore. Le esecuzioni speciali a richiesta e le opzioni non sono contemplate.

Schematic drawing to identify the main components of the motor. No special versions or options are shown here.

Disegni meccanici disponibili a richiesta, per maggiori informazioni contattare il nostro ufficio tecnico.
Mechanical drawings available on request, for detailed informations please contact our technical office.

