

# AC M2n

## AC servo motors



**Product  
Manual**

## Further descriptions, that relate to this document:

UL: 05-01-05



Planetary Gearbox PG A - Product-manual

---

UL: 05-01-06



Planetary Gearbox PG AL - Product-manual

---

UL: 05-01-07



Planetary Gearbox PG AF - Product-manual

---

UL: 12-01



Plugs - Product description

---

UL: 12-02-01



Cables - Product description

---

### ©SSD Drives GmbH.

All rights reserved. No portion of this description may be produced or processed in any form without the consent of the company.

Changes are subject to change without notice.

**SSD Drives** has registered in part trademark protection and legal protection of designs. The handing over of the descriptions may not be construed as the transfer of any rights.

Made in Germany, 2004

# CONTENTS

Page

<b>1</b>	<b>General .....</b>	<b>6</b>
1.1	Description .....	6
1.2	Type code .....	7
1.2.1	Typical example .....	7
	<b>General .....</b>	<b>8</b>
1.3	Possible options (Marking: g) .....	8
<b>2</b>	<b>General technical data .....</b>	<b>9</b>
<b>3</b>	<b>Technical data .....</b>	<b>10</b>
3.1	Torque/Speed Diagrams .....	12
3.1.1	Motor size Y and 0 .....	12
3.1.2	Motor size 1 .....	13
3.1.3	Motor size 2 .....	14
3.1.4	Motor size 3 .....	15
<b>4</b>	<b>Dimensions .....</b>	<b>16</b>
4.1	Standard design Motor size <u>Y...3</u> .....	16
4.1.1	Connections via connectors .....	16
4.2	<u>Special design</u> Motor size <u>Y...3</u> .....	17
4.2.1	Connections via PG couplings and cables .....	17
4.3	<u>B - side Motor</u> - mounting of Encodern .....	17
<b>5</b>	<b>Connector assignment .....</b>	<b>18</b>
5.1	Connector .....	18
5.2	X50 - connector .....	21
5.3	Resolver connector .....	22
5.4	Cabling instructions .....	23
5.5	Plug designation .....	24
5.5.1	Mating plugs for motor- and brake connections .....	24
5.5.2	Mating plugs for resolver- and thermal connection .....	24
5.6	Cable designation .....	24
5.6.1	Motor-cable .....	24
5.6.2	Resolver-cable .....	24

---

# CONTENTS

	Page
<b>6</b>	<b>Technical data of the holding brake ..... 25</b>
<b>7</b>	<b>Shaft loads ..... 26</b>
7.1	Notation of definition ..... 26
7.2	Technical dates of the max. radial $F_R$ (N) and axial $F_A$ (N) shaft load ..... 26
7.3	Use Ball bearing type ..... 26
<b>8</b>	<b>Nominal power dependence of the SSD Drives AC servo motors concerning the installation altitude ..... 27</b>
8.1	Short description ..... 27
<b>10</b>	<b>Notes ..... 29</b>
<b>11</b>	<b>Modification Record ..... 30</b>

## **The most important thing first**

Thanks for your confidence choosing our product.

These operating instructions present themselves as an overview of the technical data and features.

Please read the operating instructions before operating the product.

If you have any questions, please contact your nearest SSD Drives representative. Improper application of the product in combination with dangerous voltage can lead to injuries.

In addition, damage can also occur to motors or other products. Therefore please observe our safety precautions strictly.

## **Safety precautions**

We assume that, as an expert, you are familiar with the relevant safety regulations, especially in accordance with VDE 0100, VDE 0113, VDE 0160, EN 50178, the accident prevention regulations of the employers liability insurance company and the DIN regulations and that you are able to use and apply them. As well, relevant European Directives must be observed.

Depending on the kind of application, additional regulations e.g. UL, DIN are subject to be observed.

If our products are operated in connection with components from other manufacturers, their operating instructions are also subject to be observed strictly.

# 1 General

## 1.1 Description

By using high-energy magnetic materials it is possible to design small diameter disk motors. For this reason and due to a carefully optimized technical construction of the rotor, the motors have a low moment of inertia.

The stability of the magnetic material and the design of the magnetic field in the face of demagnetization allow maximum currents of up to **3- 4 times the rated current**.

The high acceleration capacity of the low-inertia three-phase AC servo drives is the result of this.

Through the excitation of the permanent magnets, no heat losses due to current occur in the rotor.

With the three-phase AC-servomotors heat losses due to current occur only in the stator, which then can be directly drawn off.

These favorable cooling conditions allow high-capacity windings.

Since all the current heat losses are drawn off directly via the surface, the motors are designed at low cost with the enclosure type providing protection in accordance with **IP xx** and they are thus very insensitive to liquids and dirt.

The resolver is built into the B-side bearing bracket.

The signals of this integrated measuring system for the actual speed value, the rotor position and the indirect position are taken at the motor over a 12-pin connector.

Synchronous three-phase AC servo drives have a series of advantages over the DC drives:

- no electromechanical parts to wear out, therefore "maintenance-free".
- a low moment of inertia of the rotor due to power density, therefore high acceleration capacity.
- no commutation limit curve, therefore high acceleration moments, also in higher speed ranges.
- no losses in the rotor of the motor, therefore favorable thermal characteristics and a high degree of protection due to the closed construction.

Three-phase AC servomotors built in the way described, are specifically more efficient (higher rated torque) than DC servomotors and also have a small inertia. Therefore the size necessary for an application will, for this reason, be smaller with three-phase AC servos than with DC servos.

### **Important !**

- The motor series AC G is not attachment- or pin-compatible to our drives AC M or AC R.
- Motor design AC G only in standard.

## General

### 1.2 Type code

Marking	Standard						optional	
	a	b	c	d	e	f	g	h
Type:	AC	XXX	XXXX	-X	/X	-X	XX	+ ...

Marking	Description
<b>a</b>	AC = three-phase
<b>b</b>	motor models: <u>G</u> = motor series <u>G</u> without cases <u>M</u> = motor series (old) <u>Mn</u> = motor series <u>n</u> new <u>M2n</u> = motor series 2 <sup>nd</sup> <u>n</u> new version <u>MHS</u> = motor series <u>H</u> iperface <u>S</u> ingleturn (under preparation) <u>MHM</u> = motor series <u>H</u> iperface <u>M</u> ultiturn <u>R</u> = motor series <u>R</u> <u>R(L)</u> = motor series <u>RL</u> with separate fan
<b>c</b>	<u>xxxx</u> = approx. rated torque in Ncm
<b>d</b>	-4 = 4000 rpm at motor type: "AC G; AC Mn; AC M2n; AC MHx" 1..6 = *1000 1/min at motor type: "AC R" -X = further on request (designation does not apply with motor / gearbox systems)
<b>e</b>	/Y..4 = motor size (designation does not apply with motor / gearbox systems)
<b>f</b>	-3 = 325 V DC intermediate circuit rated voltage ( $\cong$ 230 VAC) -6 = 565 V DC intermediate circuit rated voltage ( $\cong$ 400 VAC)
<b>g</b>	identification for <u>options</u> and custom features XX = see chapter 1.3
<b>h</b>	+ ... = with attached gear-box: (for short description for inserted gearbox models see gearbox documentation)

#### Note:

Up to marking "g" it is only necessary with options or custom features.

No options are possible for the **AC G** drive.

#### 1.2.1 Typical example

A typical example of an order corresponding to the model key would be:

Type: AC <u>G</u> 0090-4/01-3	Type: AC <u>M2n</u> 0090-4/1-3	Type: AC <u>R</u> 0095-6/1-3
AC = three phase	AC = three phase	AC = three phase
<u>G</u> = motor series	<u>M2n</u> = motor series 2 <sup>nd</sup> new	<u>R</u> = motor series
0090 = rated torque in Ncm	version	0068 = rated torque in Ncm
-4 = 4000 rpm	0090 = rated torque in Ncm	-6 = 6000 rpm
/01 = motor size	-4 = 4000 rpm	/1 = motor size
-3 = 325V DC (230 VAC)	/1 = motor size	-3 = 325V DC
	-3 = 325V DC	

## General

### 1.3 Possible options (Marking: g)

Marking	Options			and Marking	Description	motor types			
	BR	GW	IP 65			A C G	A C M n	A C M 2n	A C R
GW		X			smooth motor shaft	<input type="checkbox"/>	<input checked="" type="checkbox"/>	<input checked="" type="checkbox"/>	<input checked="" type="checkbox"/>
BR	X				holding brake, 24V DC	<input type="checkbox"/>	<input checked="" type="checkbox"/>	<input checked="" type="checkbox"/>	<input checked="" type="checkbox"/>
BBR	X				holding brake type B 24V DC	<input type="checkbox"/>	<input type="checkbox"/>	<input checked="" type="checkbox"/>	<input checked="" type="checkbox"/>
65			X		degree of protection IP 65	<input type="checkbox"/>	<input checked="" type="checkbox"/>	<input checked="" type="checkbox"/>	<input checked="" type="checkbox"/>
BG	X	X				<input type="checkbox"/>	<input checked="" type="checkbox"/>	<input checked="" type="checkbox"/>	<input checked="" type="checkbox"/>
AI					absolute or incremental encoder preparation of attachment	<input type="checkbox"/>	<input checked="" type="checkbox"/>	<input checked="" type="checkbox"/>	<input checked="" type="checkbox"/>
BI	X			AI		<input type="checkbox"/>	<input checked="" type="checkbox"/>	<input checked="" type="checkbox"/>	<input type="checkbox"/>
PL					electrical connections via PG couplings and cable ends	<input type="checkbox"/>	<input checked="" type="checkbox"/>	<input checked="" type="checkbox"/>	<input checked="" type="checkbox"/>
2P					2 <sup>nd</sup> featherkey way	<input type="checkbox"/>	<input checked="" type="checkbox"/>	<input checked="" type="checkbox"/>	<input checked="" type="checkbox"/>
6P			X	2P		<input type="checkbox"/>	<input checked="" type="checkbox"/>	<input checked="" type="checkbox"/>	<input checked="" type="checkbox"/>
90					flange receptacle for motor and resolver 90° angled	<input type="checkbox"/>	<input checked="" type="checkbox"/>	<input checked="" type="checkbox"/>	<input type="checkbox"/>
GP		X		PL		<input type="checkbox"/>	<input checked="" type="checkbox"/>	<input checked="" type="checkbox"/>	<input type="checkbox"/>
G6		X	X			<input type="checkbox"/>	<input checked="" type="checkbox"/>	<input checked="" type="checkbox"/>	<input checked="" type="checkbox"/>
MS					mech. custom designs	<input type="checkbox"/>	<input checked="" type="checkbox"/>	<input checked="" type="checkbox"/>	<input checked="" type="checkbox"/>
PU				PL	unpainted motor	<input type="checkbox"/>	<input checked="" type="checkbox"/>	<input checked="" type="checkbox"/>	<input checked="" type="checkbox"/>
PS		X		PU		<input type="checkbox"/>	<input checked="" type="checkbox"/>	<input checked="" type="checkbox"/>	<input type="checkbox"/>
SL					special finish	<input type="checkbox"/>	<input checked="" type="checkbox"/>	<input checked="" type="checkbox"/>	<input checked="" type="checkbox"/>
GK		X			smooth motor shaft shortend	<input type="checkbox"/>	<input checked="" type="checkbox"/>	<input checked="" type="checkbox"/>	<input checked="" type="checkbox"/>
VA	X	X		PL		<input type="checkbox"/>	<input checked="" type="checkbox"/>	<input checked="" type="checkbox"/>	<input type="checkbox"/>
R6			X		rust-proof motor shaft	<input type="checkbox"/>	<input checked="" type="checkbox"/>	<input checked="" type="checkbox"/>	<input type="checkbox"/>
P6			X	PL		<input type="checkbox"/>	<input checked="" type="checkbox"/>	<input checked="" type="checkbox"/>	<input type="checkbox"/>
B6	X		X			<input type="checkbox"/>	<input checked="" type="checkbox"/>	<input checked="" type="checkbox"/>	<input checked="" type="checkbox"/>
F6			X		flange receptacle B-side	<input type="checkbox"/>	<input checked="" type="checkbox"/>	<input checked="" type="checkbox"/>	<input type="checkbox"/>
VI	X	X		AI		<input type="checkbox"/>	<input checked="" type="checkbox"/>	<input checked="" type="checkbox"/>	<input checked="" type="checkbox"/>
GI		X		AI		<input type="checkbox"/>	<input checked="" type="checkbox"/>	<input checked="" type="checkbox"/>	<input checked="" type="checkbox"/>
V6	X	X	X			<input type="checkbox"/>	<input checked="" type="checkbox"/>	<input checked="" type="checkbox"/>	<input checked="" type="checkbox"/>
L6		X	X	PL		<input type="checkbox"/>	<input checked="" type="checkbox"/>	<input checked="" type="checkbox"/>	<input type="checkbox"/>
BL	X		X	PL		<input type="checkbox"/>	<input checked="" type="checkbox"/>	<input checked="" type="checkbox"/>	<input type="checkbox"/>
B4	X				flange B 14	<input type="checkbox"/>	<input checked="" type="checkbox"/>	<input checked="" type="checkbox"/>	<input type="checkbox"/>
VR		X		PL+R6+AI		<input type="checkbox"/>	<input checked="" type="checkbox"/>	<input checked="" type="checkbox"/>	<input type="checkbox"/>
S6			X	PL+R6+2P		<input type="checkbox"/>	<input checked="" type="checkbox"/>	<input checked="" type="checkbox"/>	<input type="checkbox"/>
GZ		X			with Centre hole	<input type="checkbox"/>	<input checked="" type="checkbox"/>	<input checked="" type="checkbox"/>	<input type="checkbox"/>
N6		X	X		with special rotation speed about software (6000)	<input type="checkbox"/>	<input checked="" type="checkbox"/>	<input checked="" type="checkbox"/>	<input type="checkbox"/>
HW		X			with Hollow shaft	<input type="checkbox"/>	<input checked="" type="checkbox"/>	<input checked="" type="checkbox"/>	<input type="checkbox"/>
T6			X		for tropical climate	<input type="checkbox"/>	<input checked="" type="checkbox"/>	<input checked="" type="checkbox"/>	<input type="checkbox"/>
X6				F6 + 2P		<input type="checkbox"/>	<input checked="" type="checkbox"/>	<input checked="" type="checkbox"/>	<input type="checkbox"/>

\* only motor size 3

- standard design
- ◐ optional
- ◻ not possible



## 2 General technical data

		A C	A C	A C	A C
		G	M n	M 2 n	R
Degree of protection: with mounted mating connectors and built-on motor	IP44 (with separate fan)	<input type="checkbox"/>	<input type="checkbox"/>	<input type="checkbox"/>	<input checked="" type="checkbox"/>
	IP54	<input checked="" type="checkbox"/>	<input checked="" type="checkbox"/>	<input checked="" type="checkbox"/>	<input type="checkbox"/>
	IP65	<input type="checkbox"/>	<input checked="" type="checkbox"/>	<input checked="" type="checkbox"/>	<input checked="" type="checkbox"/>
Magnetic material:	NdFeB	<input checked="" type="checkbox"/>	<input checked="" type="checkbox"/>	<input checked="" type="checkbox"/>	<input type="checkbox"/>
	SE	<input type="checkbox"/>	<input type="checkbox"/>	<input type="checkbox"/>	<input checked="" type="checkbox"/>
Electrical connections:	straight flanged sockets	<input type="checkbox"/>	<input checked="" type="checkbox"/>	<input type="checkbox"/>	<input checked="" type="checkbox"/>
	rotatable 90° angled for motor-, resolver- and thermal connection-flanged sockets	<input checked="" type="checkbox"/>	<input type="checkbox"/>	<input checked="" type="checkbox"/>	<input type="checkbox"/>
	PG couplings with cable ends	<input checked="" type="checkbox"/>	<input checked="" type="checkbox"/>	<input checked="" type="checkbox"/>	<input type="checkbox"/>
Thermal protection of motor:	thermal detector PTC	<input checked="" type="checkbox"/>	<input checked="" type="checkbox"/>	<input checked="" type="checkbox"/>	<input checked="" type="checkbox"/>
Power:	In accordance with DIN VDE 0530 installation site: 1000 ASL T = 100K, Tu 40°C measured with attached cooling surface	<input checked="" type="checkbox"/>	<input checked="" type="checkbox"/>	<input checked="" type="checkbox"/>	<input checked="" type="checkbox"/>
Voltage:	325 V DC	<input checked="" type="checkbox"/>	<input checked="" type="checkbox"/>	<input checked="" type="checkbox"/>	<input checked="" type="checkbox"/>
	565 V DC	<input type="checkbox"/>	<input checked="" type="checkbox"/>	<input checked="" type="checkbox"/>	<input checked="" type="checkbox"/>
	other windings are possible.	<input type="checkbox"/>	<input checked="" type="checkbox"/>	<input checked="" type="checkbox"/>	<input type="checkbox"/>
Cooling:	self-cooling	<input checked="" type="checkbox"/>	<input checked="" type="checkbox"/>	<input checked="" type="checkbox"/>	<input checked="" type="checkbox"/>
	separate cooling	<input type="checkbox"/>	<input type="checkbox"/>	<input type="checkbox"/>	<input checked="" type="checkbox"/>
Operating mode:	Continuous operation S1	<input checked="" type="checkbox"/>	<input checked="" type="checkbox"/>	<input checked="" type="checkbox"/>	<input checked="" type="checkbox"/>
Bearings:	Ball bearings, service life approx. 15.000 h	<input checked="" type="checkbox"/>	<input checked="" type="checkbox"/>	<input checked="" type="checkbox"/>	<input checked="" type="checkbox"/>
Motor shaft: (standard)	with fitting key in accordance with DIN 6885	<input checked="" type="checkbox"/>	<input checked="" type="checkbox"/>	<input checked="" type="checkbox"/>	<input checked="" type="checkbox"/>
Rotational accuracy:	N, in acc. with DIN ISO 2373	<input checked="" type="checkbox"/>	<input checked="" type="checkbox"/>	<input checked="" type="checkbox"/>	<input checked="" type="checkbox"/>
Number of pole pairs:	2	<input type="checkbox"/>	<input type="checkbox"/>	<input type="checkbox"/>	<input checked="" type="checkbox"/>
	3	<input checked="" type="checkbox"/>	<input checked="" type="checkbox"/>	<input checked="" type="checkbox"/>	<input checked="" type="checkbox"/>
Resolver type:	2 pole SSD Drives transmitter resolver	<input checked="" type="checkbox"/>	<input checked="" type="checkbox"/>	<input checked="" type="checkbox"/>	<input type="checkbox"/>
	2 pole standard transmitter resolver	<input type="checkbox"/>	<input type="checkbox"/>	<input type="checkbox"/>	<input checked="" type="checkbox"/>
Insulation class	F (VDE 0530) 155° C, heating 100° K	<input checked="" type="checkbox"/>	<input checked="" type="checkbox"/>	<input checked="" type="checkbox"/>	<input checked="" type="checkbox"/>
Varnish: (standard)	similar RAL 9005 (black)	<input checked="" type="checkbox"/>	<input checked="" type="checkbox"/>	<input checked="" type="checkbox"/>	<input checked="" type="checkbox"/>

- standard design
- optional
- not possible

- ★ dependent on size
- ◆ only with larger quantities

### 3 Technical data

#### Type: AC M2n

AC-Servo motor Type:	size	Technical data				Static torque	Static current	max. Static torque	Moment of inertia included resolver	
		Nominal power	Rated torque	Rated current with 325V DC 565V DC						
		P <sub>N</sub> (KW)	M <sub>N</sub> (Nm)	I <sub>N325</sub> (A)	I <sub>N565</sub> (A)	M <sub>0</sub> (Nm)	I <sub>0</sub> (A)	M <sub>0max</sub> (Nm)	J <sub>M</sub> (kgcm <sup>2</sup> )	
AC M2n0012-6/Y-3	<sup>1)</sup> Y	0,075	0,12	0,33	-	0,16	0,44	0,64	0,05	
AC M2n0010-4/0-3	0	0,040	0,10	0,20	-	0,13	0,25	0,52	0,05	
AC M2n0030-4/0-3		0,126	0,30	0,80	-	0,30	0,90	1,20	0,10	
AC M2n0045-4/0-3		0,189	0,45	1,08	-	0,50	1,20	2,00	0,15	
AC M2n0045-4/0-6	0	0,189	0,45	-	0,60	0,50	0,65	2,00	0,15	
AC M2n0070-4/0-3		0,293	0,70	1,46	-	0,80	1,60	3,20	0,20	
AC M2n0070-4/0-6		0,293	0,70	-	0,82	0,80	0,90	3,20	0,20	
AC M2n0130-4/0-3	<sup>1)</sup>	0,545	1,30	2,80	-	1,50	3,30	6,00	0,33	
AC M2n0130-4/0-6	<sup>1)</sup>	0,545	1,30	-	1,40	1,50	1,65	6,00	0,33	
AC M2n0055-4/1-3	1	0,230	0,55	1,40	-	0,80	2,10	3,20	0,30	
AC M2n0055-4/1-6		0,230	0,55	-	0,76	0,80	1,20	3,20	0,30	
AC M2n0090-4/1-3		0,377	0,90	1,80	-	1,50	3,00	6,00	0,68	
AC M2n0090-4/1-6	1	0,377	0,90	-	1,10	1,50	1,80	6,00	0,68	
AC M2n0150-4/1-3		0,628	1,50	3,00	-	2,50	5,00	10,00	1,00	
AC M2n0150-4/1-6		0,628	1,50	-	1,90	2,50	2,70	10,00	1,00	
AC M2n0220-4/1-3	1	0,922	2,20	4,70	-	3,00	6,40	12,00	1,40	
AC M2n0220-4/1-6		0,922	2,20	-	2,80	3,00	3,80	12,00	1,40	
AC M2n0290-4/1-3		1,215	2,90	6,00	-	4,00	8,30	16,00	1,80	
AC M2n0290-4/1-6	1	1,215	2,90	-	3,00	4,00	4,20	16,00	1,80	
AC M2n0320-4/2-3		2	1,340	3,20	6,40	-	4,00	8,20	16,00	2,40
AC M2n0320-4/2-6			1,340	3,20	-	3,60	4,00	4,50	16,00	2,40
AC M2n0480-4/2-3	2,010		4,80	9,80	-	7,00	14,30	28,00	3,20	
AC M2n0480-4/2-6	2	2,010	4,80	-	4,90	7,00	7,20	28,00	3,20	
AC M2n0650-4/2-3		2,720	6,50	13,20	-	9,00	18,30	36,00	3,60	
AC M2n0650-4/2-6		2,720	6,50	-	6,60	9,00	9,20	36,00	3,60	
AC M2n0830-4/2-6	2	3,480	8,30	-	9,30	11,00	12,30	44,00	4,50	
AC M2n0960-4/3-6		<sup>2)</sup> 3	4,020	9,60	-	11,00	16,00	18,40	64,00	6,15
AC M2n1200-4/3-6		<sup>2)</sup>	5,030	12,00	-	16,00	21,00	28,00	84,00	7,70
AC M2n2000-4/3-6	<sup>2)</sup>	8,370	20,00	-	19,30	34,00	33,00	136,00	12,50	

T-03-05-03-E-001-V02.xls

**Size Y** Data at rated speed of 6000 rpm

**Size 0 –3** Data at rated speed of 4000 rpm

<sup>1)</sup> not with holding brake equip !

<sup>2)</sup> The servo motors possess approx. 10 - 15% higher moment of inertia (J<sub>M</sub>), in the middle of 2003.

## Technical data

### Type: AC M2n

AC-Servo motor Type:	size	Mass	Motor resistance	Motor inductance	Thermal time constant		Torque constant	e.m.f constant eff.	
					with IN	with Imax			
		m (kg)	Rph/ph (Ω)	Lph/ph (mH)	T <sub>thN</sub> (min)	T <sub>thmax</sub> (s)	K <sub>T</sub> (Nm/A)	K <sub>E</sub> (V/1000 min-1)	
AC M2n0012-6/Y-3	<sup>1)</sup> Y	1,01	35,00	22,00	11	28	0,38	23	
AC M2n0010-4/0-3	0	0,83	122,00	66,00	7	18	0,50	30	
AC M2n0030-4/0-3		1,30	18,30	13,00	10	26	0,40	26	
AC M2n0045-4/0-3		1,60	12,00	14,30	12	31	0,41	28	
AC M2n0045-4/0-6		1,60	32,00	28,00	12	31	0,74	47	
AC M2n0070-4/0-3		1,90	8,90	9,30	14	36	0,50	28	
AC M2n0070-4/0-6		1,90	27,70	23,00	14	36	0,83	50	
AC M2n0130-4/0-3		<sup>1)</sup>	2,80	3,80	4,60	14	36	0,46	28
AC M2n0130-4/0-6		<sup>1)</sup>	2,80	13,70	13,90	14	36	0,92	51
AC M2n0055-4/1-3	1	2,00	6,30	14,30	20	51	0,39	26	
AC M2n0055-4/1-6		2,00	18,40	39,00	20	51	0,66	44	
AC M2n0090-4/1-3		2,90	3,10	9,20	20	51	0,50	30	
AC M2n0090-4/1-6		2,90	7,70	24,00	20	51	0,83	50	
AC M2n0150-4/1-3		3,70	1,70	6,00	23	59	0,50	30	
AC M2n0150-4/1-6		3,70	5,20	16,70	23	59	0,94	59	
AC M2n0220-4/1-3		4,30	1,10	4,30	26	66	0,50	33,5	
AC M2n0220-4/1-6		4,30	2,80	11,00	26	66	0,83	52	
AC M2n0290-4/1-3		5,30	0,80	3,20	30	77	0,48	33	
AC M2n0290-4/1-6		5,30	2,40	9,30	30	77	0,97	55	
AC M2n0320-4/2-3	2	6,00	1,00	5,50	19	49	0,49	35	
AC M2n0320-4/2-6		6,00	2,80	13,60	19	49	0,98	60	
AC M2n0480-4/2-3		7,60	0,40	2,30	29	74	0,49	30	
AC M2n0480-4/2-6		7,60	2,00	11,30	29	74	0,98	68	
AC M2n0650-4/2-3		8,50	0,47	1,90	38	97	0,49	33	
AC M2n0650-4/2-6		8,50	1,30	7,60	38	97	0,98	60	
AC M2n0830-4/2-6		16,00	0,80	4,70	50	128	0,89	54	
AC M2n0960-4/3-6	3	19,50	0,60	6,10	36	92	0,87	58	
AC M2n1200-4/3-6		22,00	0,30	3,20	52	133	0,75	48	
AC M2n2000-4/3-6		30,00	0,30	3,80	88	225	1,04	65	

T-03-05-03-E-002-V02.xls

$$K_T \approx K_{T_0} \approx K_{T_N}$$

**Size Y** Data at rated speed of 6000 rpm  
**Size 0 – 3** Data at rated speed of 4000 rpm

<sup>1)</sup> not with holding brake equip !

## Technical data

### 3.1 Torque/Speed Diagrams

#### 3.1.1 Motor size Y and 0

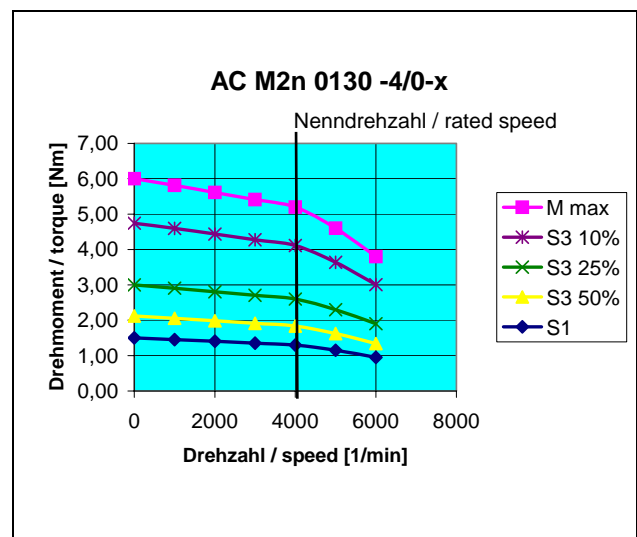
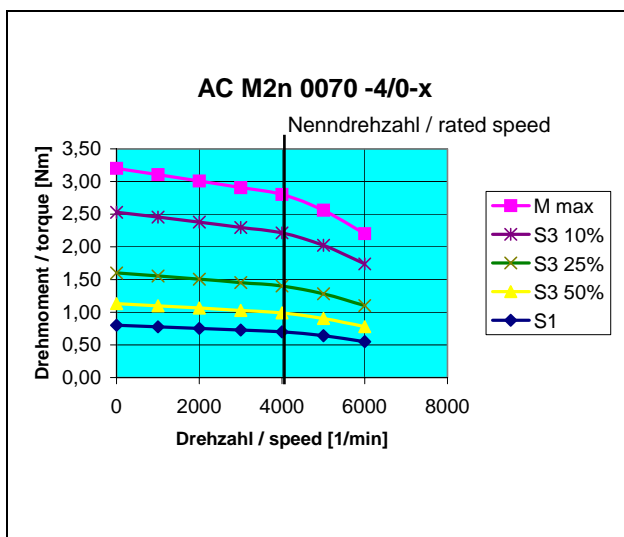
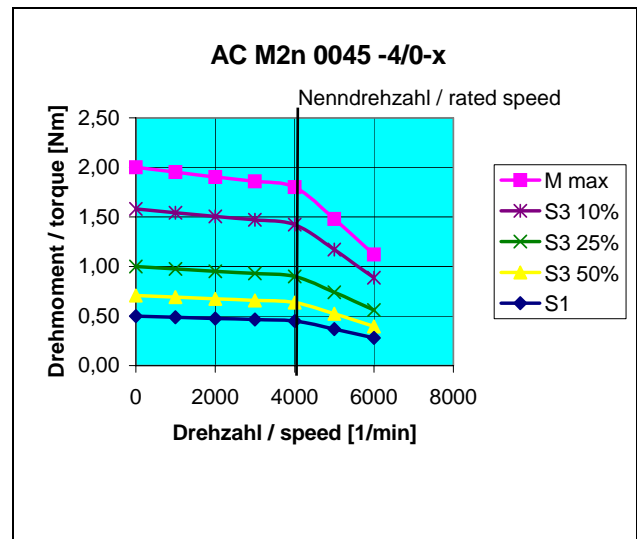
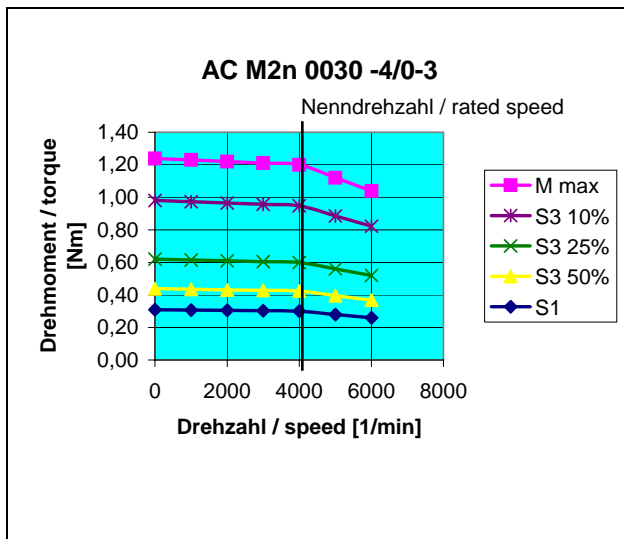
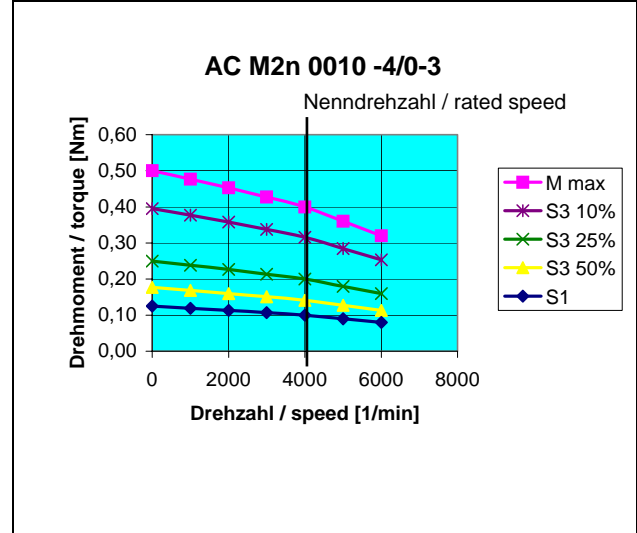
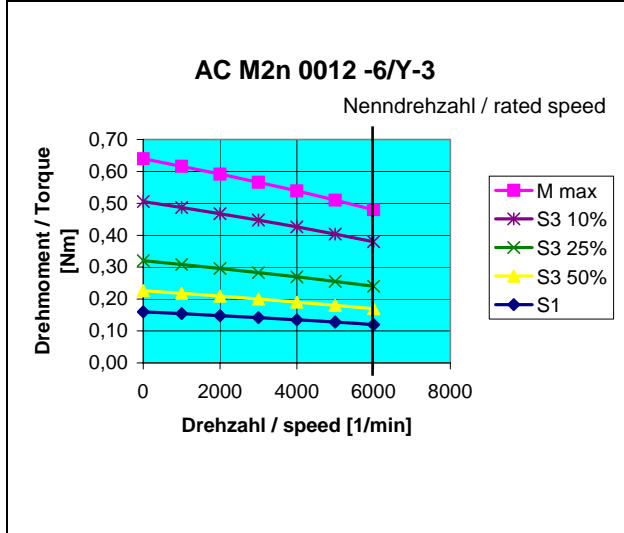

# Technical data

## Torque/Speed Diagrams

### 3.1.2 Motor size 1

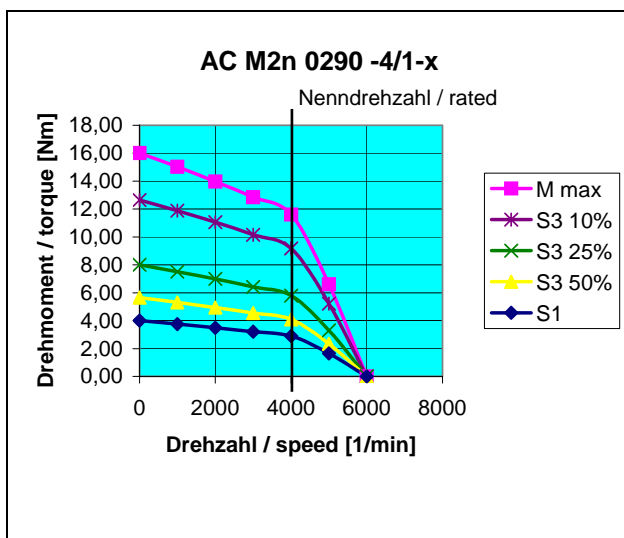
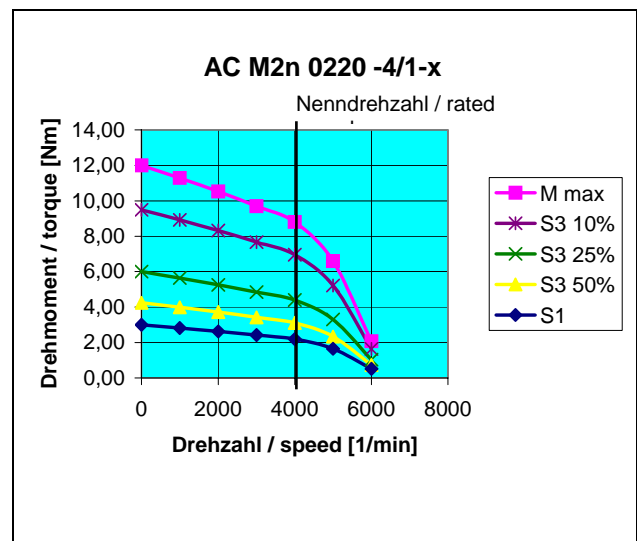
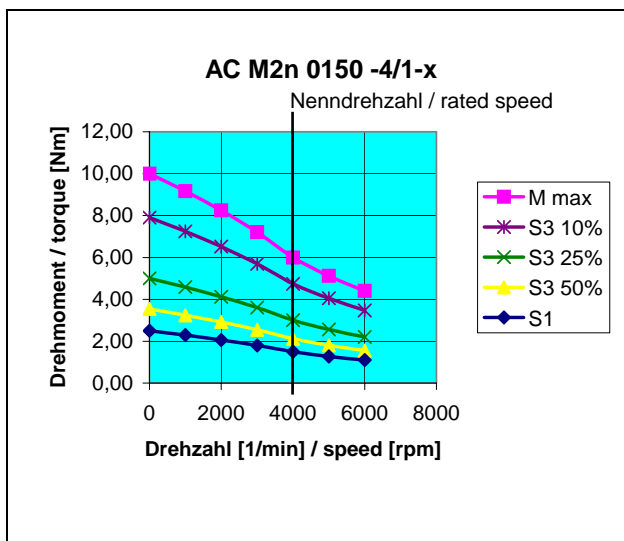
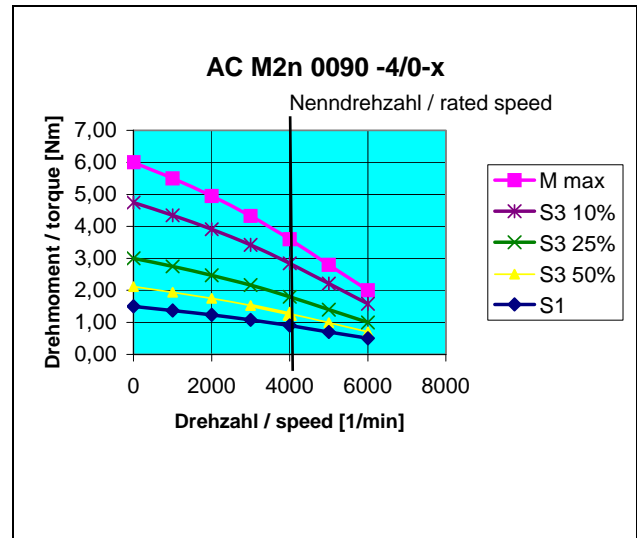
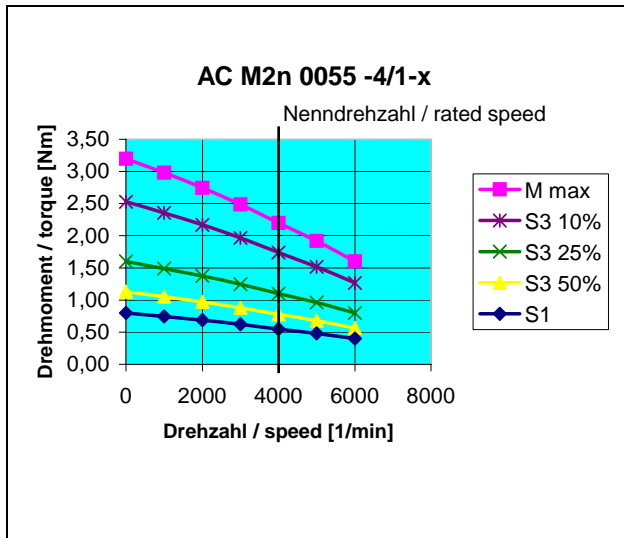

# Technical data

## Torque/Speed Diagrams

### 3.1.3 Motor size 2

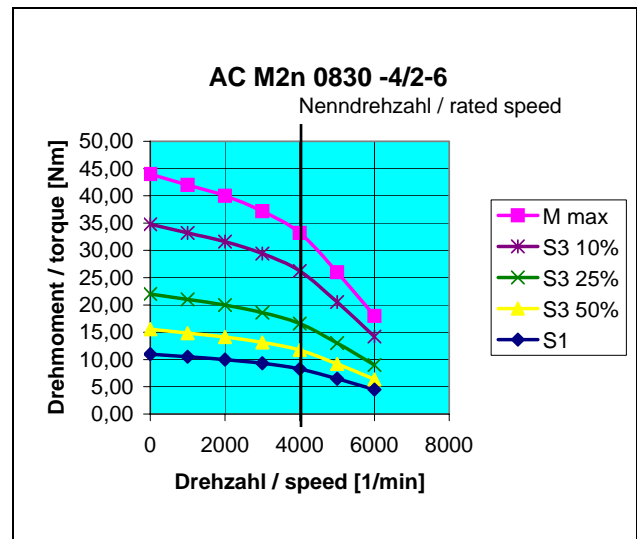
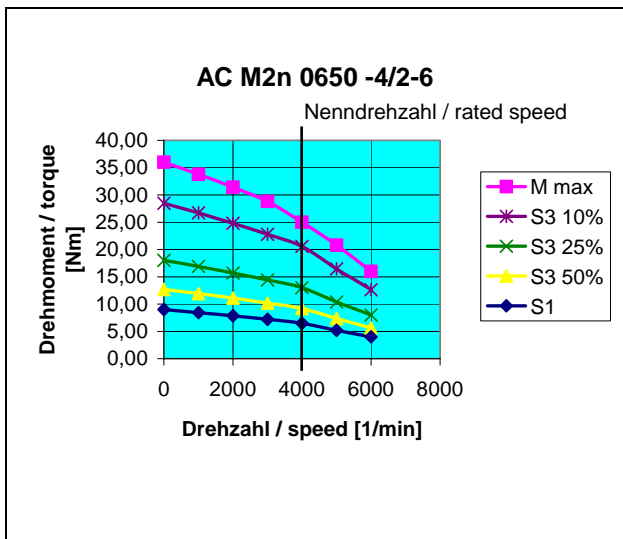
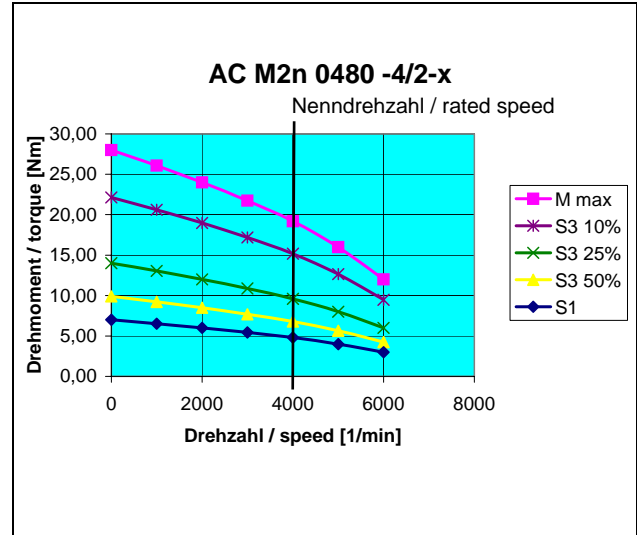
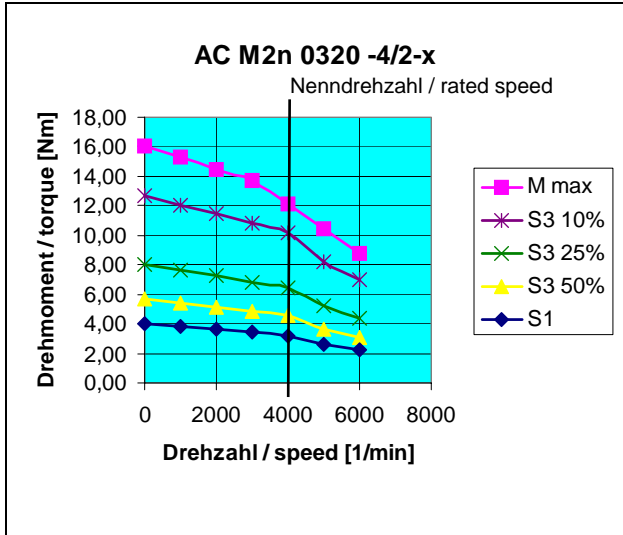

# Technical data

## Torque/Speed Diagrams

### 3.1.4 Motor size 3

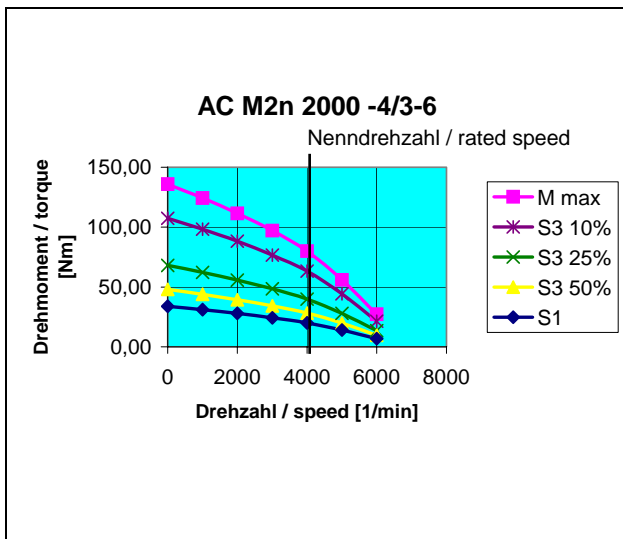
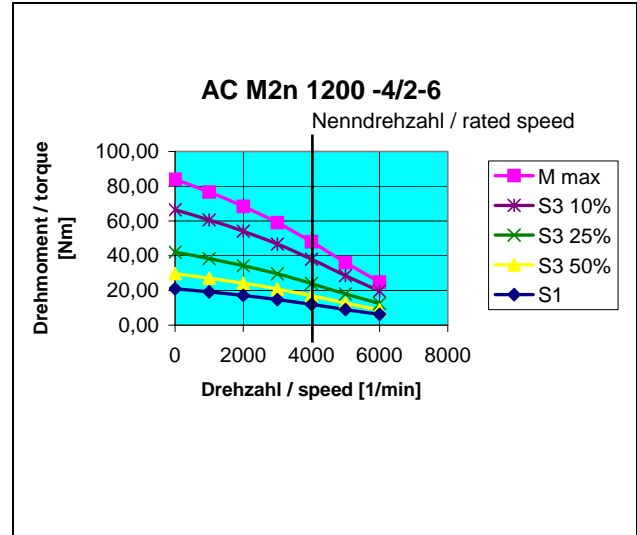
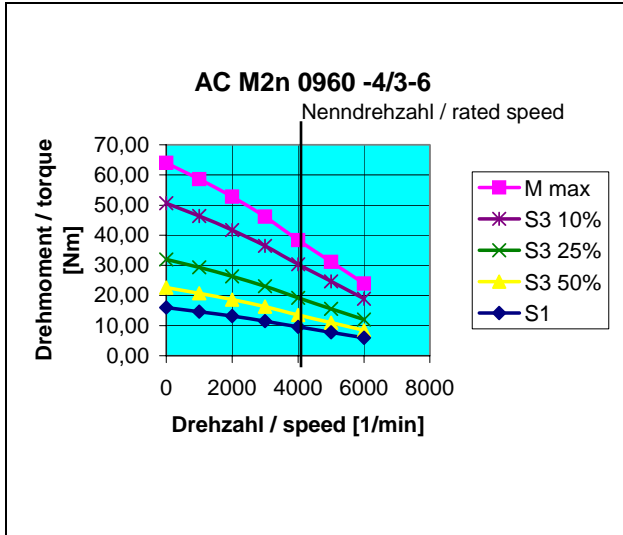

## 4 Dimensions

### 4.1 Standard design Motor size Y...3

#### 4.1.1 Connections via connectors

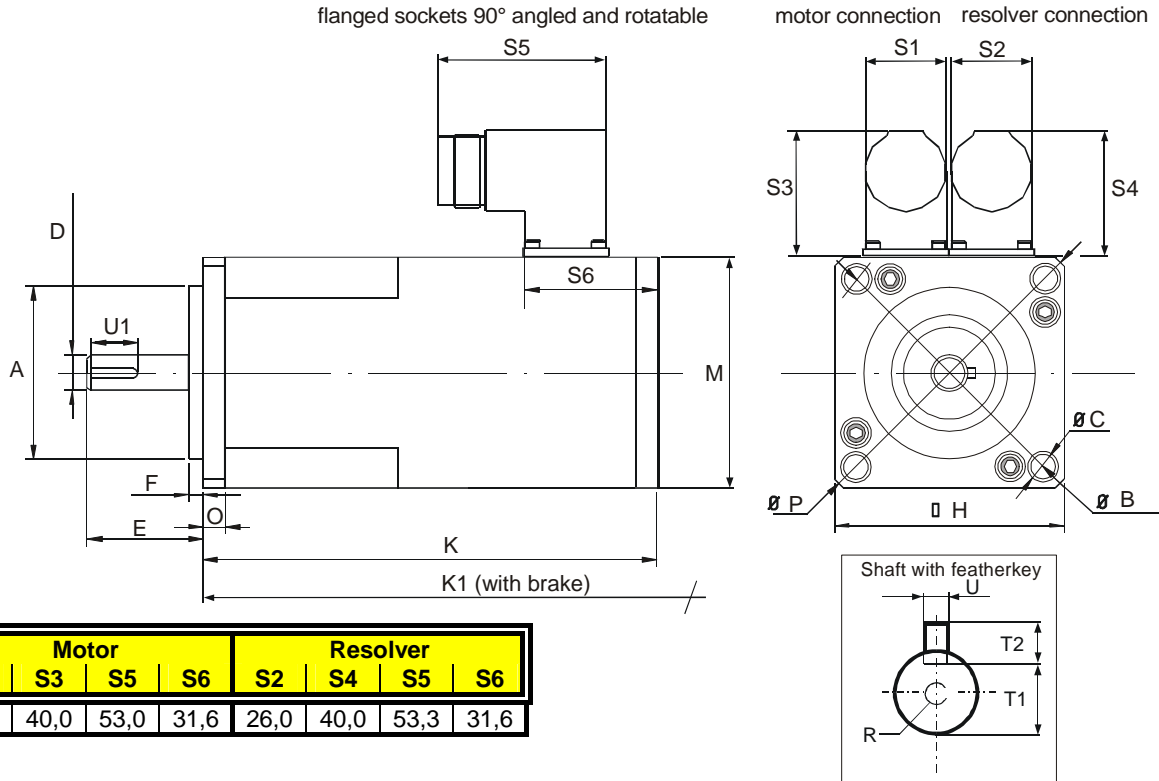

model	size	A (j6)	B	C	D (k6)	E	F	H	K	K1	M	O	P	R	T1	T2 (h9)	U (h9)	U1
AC M2n0012.. <sup>4)</sup>	Y	30	46	4,3	6	20	2,5	40	130	-	40	0	54	-	-	-	-	-
AC M2n0010..	0	40	63	5,8	9	24	2,5	55	98	131	55	8	74	M3-10	7,2	3	3	14
AC M2n0030..		40	63	5,8	9	24	2,5	55	123	156	55	8	74	M3-10	7,2	3	3	14
AC M2n0045..		40	63	5,8	9	24	2,5	55	143	176	55	8	74	M3-10	7,2	3	3	14
AC M2n0070..		40	63	5,8	9	24	2,5	55	163	196	55	8	74	M3-10	7,2	3	3	14
AC M2n0130.. <sup>1)</sup>		40	63	5,8	9	24	2,5	55	234	-	55	8	74	M3-10	7,2	3	3	14
AC M2n0055..	1	80	100	7	14	30	3	88	112	153	82	10	115	M4-12	11,1	5	5	20
AC M2n0090..		80	100	7	14	30	3	88	132	173	82	10	115	M4-12	11,1	5	5	20
AC M2n0150..		80	100	7	14	30	3	88	152	193	82	10	115	M4-12	11,1	5	5	20
AC M2n0220..		80	100	7	14	30	3	88	172	213	82	10	115	M4-12	11,1	5	5	20
AC M2n0290.. <sup>2)</sup>		80	100	7	14	30	3	88	202	249	82	10	115	M4-12	11,1	5	5	20
AC M2n0290.. <sup>2)</sup>		80	100	7	14	30	3	88	202	249	82	10	115	M4-12	11,1	5	5	20
AC M2n0320..	2	95	115	9	19	40	3	105	178	218	105	12	134	M6-15	15,5	6	6	30
AC M2n0480..		95	115	9	19	40	3	105	208	248	105	12	134	M6-15	15,5	6	6	30
AC M2n0650..		95	115	9	19	40	3	105	228	268	105	12	134	M6-15	15,5	6	6	30
AC M2n0830.. <sup>3)</sup>		95	115	9	19	40	3	105	273	313	105	12	115	M6-15	15,5	6	6	30
AC M2n0960..	3	130	165	11	24	50	3,5	145	260	303	145	12	188	M8-25	19,9	7	8	40
AC M2n1200..		130	165	11	24	50	3,5	145	300	343	145	12	188	M8-25	19,9	7	8	40
AC M2n2000..		130	165	11	24	50	3,5	145	420	463	145	12	188	M8-25	19,9	7	8	40

<sup>1)</sup> not with holding brake equip

<sup>2)</sup> K1 with 6 Nm holding brake

<sup>3)</sup> design only with smooth shaft and PG coupling

all specifications in "mm"



## Dimensions

### 4.2 Special design Motor size Y...3

#### 4.2.1 Connections via PG couplings and cables

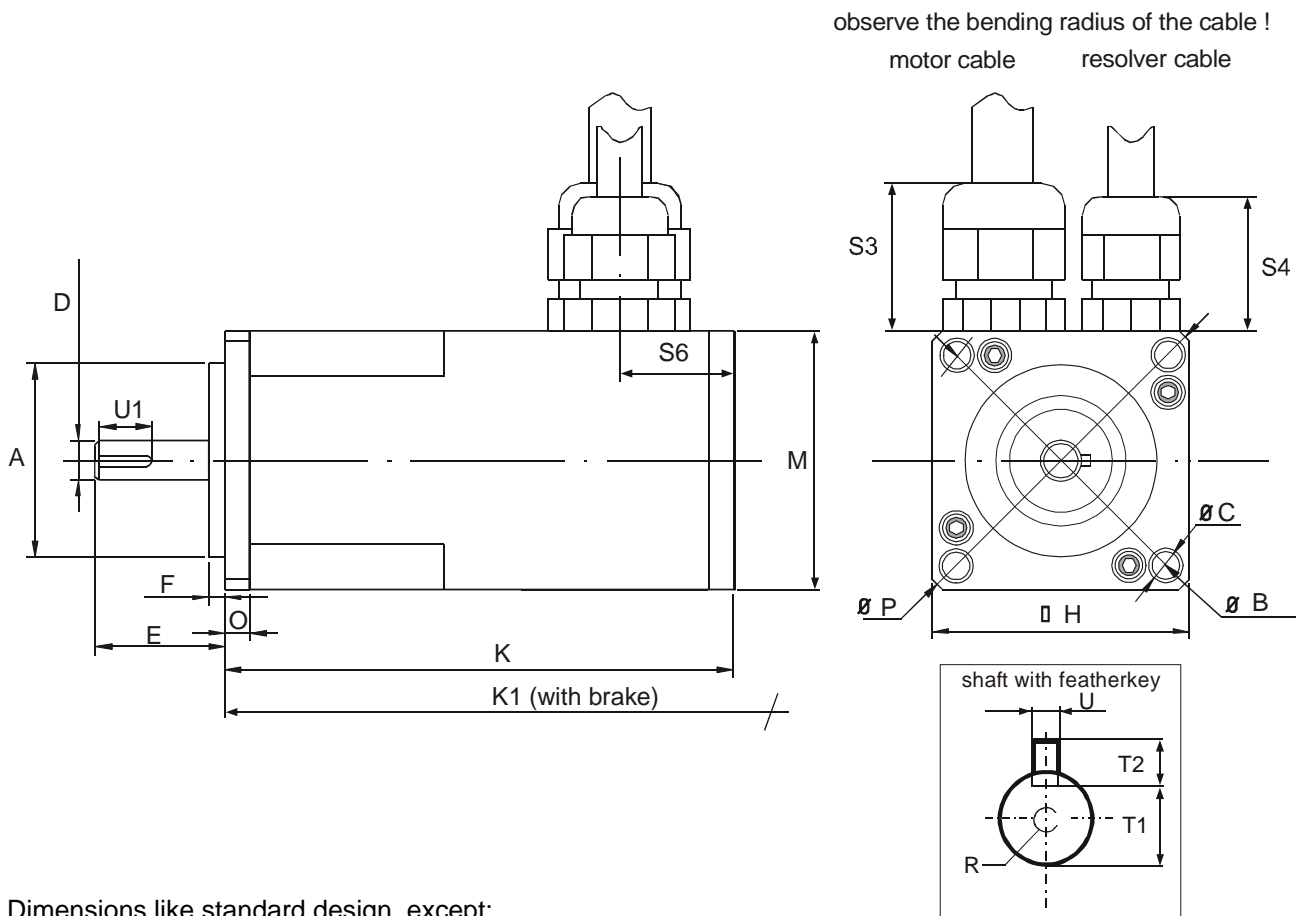

Dimensions like standard design, except:

AC <u>M2n</u> size	S3		S4		S6	Motor connection via PG coupling	Resolver connection via PG coupling	Comments
	Design Skintop	EMV	Design Skintop	EMV				
Y	25	-	22	-	16	-	-	cable low cost
0	28	21	25	20	18	13,5	9	-
1	28	21	25	20	18	13,5	9	-
2	28	21	25	20	20	13,5	9	-
3	-	-	-	-	-	-	-	Dimensions on request

### Important !

- Observe the bending radius of the cables, see cable documentation **12-02-01 !**

### 4.3 B - side Motor - mounting of Encodern

Please, request when required separate dimensional drawing.

### Important !

- Additional connection plug connector or cable end
- Change of the engine length, dimension K or K1

# 5 Connector assignment

## 5.1 Connector

### Power connector

**motor side**

SSD Drives - motor - size Y

Type: AC M2n

**reguator side**

SSD Drives - Servo drive

Type: 631/635 und 637/637+/637f  
in the compact enclosure

PG - gland	K MB BG 0/2-BLC KA.0003.xxxx		terminal strip
	colour	function	Pin - No.
	black 1	motor connection	M1
	yello/green	ground connection	PE
	black 2	motor connection	M2
	black 3	motor connection	M3
		screen	case

				Maßstab / scale:	
				Typ / Type: PG-Low cost	
		Bear.	26.08.02	DL	Bezeichnung / designation: Blue low cost motor cable for SSD Drives standard motors BG Y and servo drives
		Gep.	29.08.02	EH	
		Norm			
				Zeichnungsnummer / drawing No: Z-MK.PG.xxxx	
01	637f	16.04.03	DL		Blatt 1
Zust.	Änderung	Datum	Name	Ursprung	Dateiname / file name: Z-MK-PG-E.cdr

# Connector assignment

## Connector

### Power connector

#### motor side

SSD Drives - motor size 0...2

Model: AC G, AC M2n; ACM2G; AC M2K  
**AC MHS / MHM**

#### regulator side

SSD Drives - Servo drives

Model: 631/635 and 637/637+/637f  
**637+/637f**  
in the compact enclosure

#### view solder / crimp connector - side

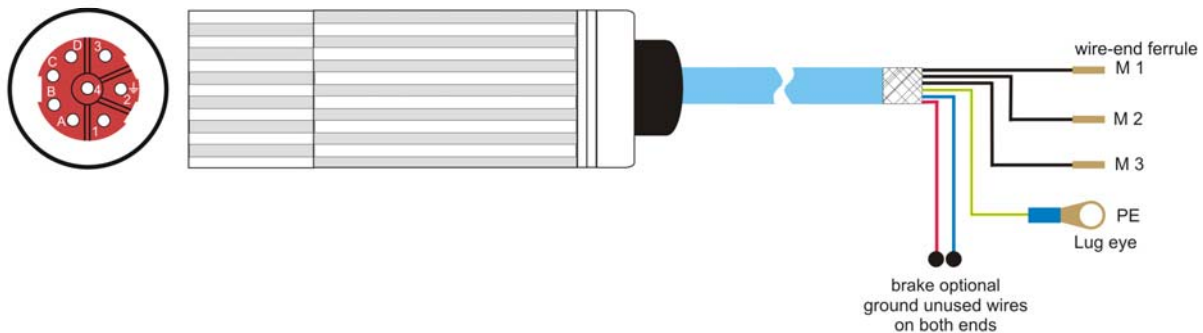

S MB GM2nRn BG 0/3-C+L ST.0100.3001		K MB BG 0/2-B KA.0003.6304		terminal strip	
PIN - Nr.		colour		function	
1		black 1		motor connection	
2		yellow/green		ground connection	
3		black 2		motor connection	
4		black 3		motor connection	
A		red		brake +24V DC <sup>2)</sup>	
B		blue		brake 0V DC <sup>2)</sup>	
C		-		-	
D		-		-	
case		1)		screen	

<sup>1)</sup> motor mating plug  
the screen is connected to  
the groundpin and also  
extensively to the case.

<sup>2)</sup> **Attention ! Security and insulation:**  
The brake must be insulated for secure division (PELV). Otherwise,  
the insulation class of the drive becomes reduced or the effort  
of an additional galvanic separation is required.

				Maßstab / scale:		Typ / model:																	
						KK MB GM2nRn 0/2.K - XX.X / B																	
<table border="1"> <tr> <td>Bear.</td> <td>06.02.02</td> <td>DL</td> <td></td> </tr> <tr> <td>Gep.</td> <td>14.02.02</td> <td>EH</td> <td></td> </tr> <tr> <td>DL</td> <td></td> <td></td> <td></td> </tr> <tr> <td>Norm</td> <td></td> <td></td> <td></td> </tr> </table>				Bear.	06.02.02	DL		Gep.	14.02.02	EH		DL				Norm				<b>Bezeichnung / designation:</b> Blue motor cable (compact enclosure) for SSD Drives standard motors and servo drives			
Bear.	06.02.02	DL																					
Gep.	14.02.02	EH																					
DL																							
Norm																							
<table border="1"> <tr> <td>04</td> <td>ACM2K</td> <td>10.08.04</td> <td></td> </tr> <tr> <td>03</td> <td>ACM2G</td> <td>15.08.03</td> <td>DL</td> </tr> <tr> <td>02</td> <td>637f</td> <td>16.04.03</td> <td>DL</td> </tr> <tr> <td>01</td> <td>Motor-size</td> <td>06.02.02</td> <td>DL</td> </tr> </table>				04	ACM2K	10.08.04		03	ACM2G	15.08.03	DL	02	637f	16.04.03	DL	01	Motor-size	06.02.02	DL	<b>Zeichnungsnummer / drawing No:</b> Z-MK.6400.xxxx			
04	ACM2K	10.08.04																					
03	ACM2G	15.08.03	DL																				
02	637f	16.04.03	DL																				
01	Motor-size	06.02.02	DL																				
Zust. Änderung Datum Name Ursprung				Dateiname / File name: Z-MK-6400-E.cdr																			
						Blatt sheet 1																	

# Connector assignment

## Connector

### Power connector

#### motor side

SSD Drives - motor size 3

Model: AC M2n  
**AC MHS / MHM**  
**AC MRW**

#### regulator side

SSD Drives - Servo drives

Model: 631/635 and 637/637+/637f  
**637+/637f**  
 in the compact enclosure

#### view solder / crimp connector - side

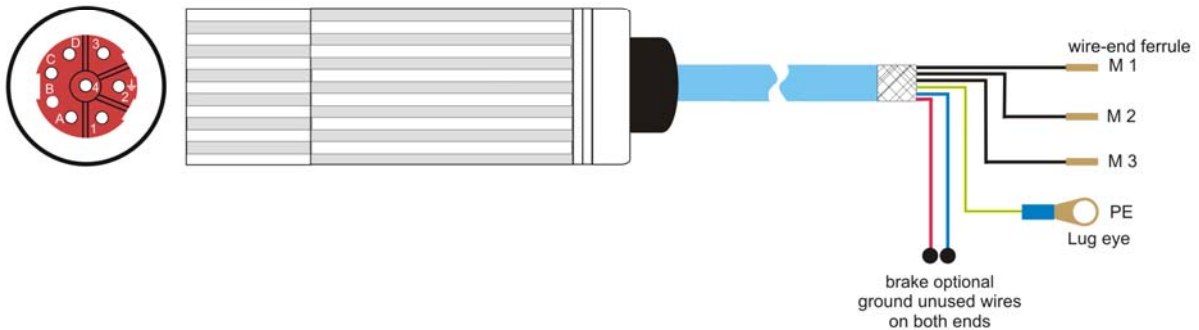

S MB GM2nRn BG 0/3-C+L ST.0100.3001	K MB BG 3-B KA.0003.6302		terminal strip
PIN - Nr.	colour	function	PIN - Nr.
1	black 1	motor connection	M1
2	<sup>1)</sup> yellow/green	ground connection	PE
3	black 2	motor connection	M2
4	black 3	motor connection	M3
A	red	brake +24V DC	<sup>2)</sup> Connection
B	blue	brake 0V DC	<sup>2)</sup> not on terminal
C	-	-	-
D	-	-	-
case	<sup>1)</sup>	screen	case

<sup>1)</sup> motor mating plug  
 the screen is connected to  
 the groundpin and also  
 extensively to the case.

<sup>2)</sup> **Attention ! Security and insulation:**  
 The brake must be insulated for secure division (PELV). Otherwise,  
 the insulation class of the drive becomes reduced or the effort  
 of an additional galvanic separation is required.

**Caution !** at X50 connector a terminal block must be employed

				Maßstab / scale:			
				Typ / model:		KK MB M2nRn 3	
Bear. 06.02.02 DL				Bezeichnung / designation: Blue motor cable for SSD Drives AC M2n size 3 motors and servo drives			
Gep. 14.02.02 EH							
Norm							
				Zeichnungsnummer / drawing No:		Blatt sheet	
				Z-MK.6401.xxxx		1	
01	637f	16.04.03	DL	Dateiname / File name: Z-MK.6401-E.cdr			
Zust.	Änderung	Datum	Name	Ursprung			

# Connector assignment

## 5.2 X50 - connector

**motor side**

SSD Drives - motor size 0...2

Model: AC M2n; ACM2G; AC M2K  
**AC MHS / MHM**

**X50 - connector**

**regulator side**

SSD Drives - servo drives

Model: 635 and 637/637+/637f  
**637+/637f**  
in the Rack

**view solder / crimp connector - side**

S MB GM2nRn BG 0/3-C+L ST.0100.3001	K MB BG 0/2-B KA.0003.6304		X50 connector strip	<sup>3)</sup>
PIN - Nr.	colour	function	PIN - Nr.	
1	black 1	motor connection	10	
2	<sup>1)</sup> yellow/green	ground connection	12	
3	black 2	motor connection	14	
4	black 3	motor connection	16	
A	red	brake +24V DC	18	
B	blue	brake 0V DC	20	
C	-	-	-	
D	-	-	-	
case	<sup>1)</sup>	screen	case	

<sup>1)</sup> motor mating plug the screen is connected to the groundpin and also extensively to the case.

<sup>2)</sup> **Attention ! Security and insulation:**  
The brake must be insulated for secure division (PELV). Otherwise, the insulation class of the drive becomes reduced or the effort of an additional galvanic separation is required.

<sup>3)</sup> not in the Scope of delivery

				Maßstab / scale:																																													
				Typ / model:		KK MB GM2nRn 0/2.R - XX.X / B																																											
<table border="1" style="width: 100%; border-collapse: collapse;"> <tr> <td></td><td></td><td></td><td></td><td>Bear.</td><td>10.05.01</td><td>DL</td></tr> <tr> <td>04</td><td>ACM2K</td><td>10.08.04</td><td>DL</td><td>Gep.</td><td>11.05.01</td><td>EH</td></tr> <tr> <td>03</td><td>ACM2G</td><td>15.08.03</td><td>DL</td><td>Norm</td><td></td><td></td></tr> <tr> <td>02</td><td>637f</td><td>16.04.03</td><td>DL</td><td></td><td></td><td></td></tr> <tr> <td>01</td><td>Motor-size</td><td>06.02.02</td><td>DL</td><td></td><td></td><td></td></tr> <tr> <td>Zust</td><td>Änderung</td><td>Datum</td><td>Name</td><td>Ursprung</td><td></td><td></td></tr> </table>								Bear.	10.05.01	DL	04	ACM2K	10.08.04	DL	Gep.	11.05.01	EH	03	ACM2G	15.08.03	DL	Norm			02	637f	16.04.03	DL				01	Motor-size	06.02.02	DL				Zust	Änderung	Datum	Name	Ursprung			Bezeichnung / designation:		Blue motor cable (plugs/terminal strip) for SSD Drives standard motors and servo drives	
								Bear.	10.05.01	DL																																							
04	ACM2K	10.08.04	DL	Gep.	11.05.01	EH																																											
03	ACM2G	15.08.03	DL	Norm																																													
02	637f	16.04.03	DL																																														
01	Motor-size	06.02.02	DL																																														
Zust	Änderung	Datum	Name	Ursprung																																													
				Zeichnungsnummer / drawing No:		Z-MK.0400.xxxx																																											
				Dateiname / File name:		Z-MK-0400-E.cdr																																											

# Connector assignment

## 5.3 Resolver connector

### Resolver connector

**motor side**

SSD Drives - motor size 0...4

Type: AC G, AC R, AC Mn,  
AC M2n, AC M2K; ACM2G  
AC MRW, AC MRL

**view solderside**

**regulator side**

SSD Drives - servo drives

Model: 631/635 and 637/637+/637f

**view solderside**

SIR ST.0200.0001	KIR -B KA.0003.6301		SUB - D 09 S/M ST.1002.2001
PIN - Nr.	colour	function	PIN - Nr.
1	white	sin +	4
2	brown	sin -	8
3	green	cos +	3
4	yellow	cos -	7
5	red	PTC optional	2
6	blue	PTC optional	6
7	pink	carrier -	9
8	gray	carrier +	5
case		screen	case

				Maßstab / scale:																																					
				Typ / model: KK RT GMR-xx.x/B																																					
<table border="1" style="width: 100%; border-collapse: collapse;"> <tr> <td style="width: 5%;">05</td> <td style="width: 15%;">ACM2K</td> <td style="width: 10%;">10.08.04</td> <td style="width: 5%;">DL</td> <td style="width: 5%;">Bear.</td> <td style="width: 10%;">09.05.01</td> <td style="width: 5%;">DL</td> </tr> <tr> <td>04</td> <td>ACMRL</td> <td>27.11.03</td> <td>DL</td> <td>Gep.</td> <td>10.05.01</td> <td>EH</td> </tr> <tr> <td>03</td> <td>ACMRW</td> <td>02.10.03</td> <td>DL</td> <td>Norm</td> <td></td> <td></td> </tr> <tr> <td>02</td> <td>ACM2G</td> <td>15.08.03</td> <td>DL</td> <td></td> <td></td> <td></td> </tr> <tr> <td>01</td> <td>637f</td> <td>16.04.03</td> <td>DL</td> <td></td> <td></td> <td></td> </tr> </table>				05	ACM2K	10.08.04	DL	Bear.	09.05.01	DL	04	ACMRL	27.11.03	DL	Gep.	10.05.01	EH	03	ACMRW	02.10.03	DL	Norm			02	ACM2G	15.08.03	DL				01	637f	16.04.03	DL				Bezeichnung / designation: Blue resolver cable for SSD Drives standard motors and servo drives		
				05	ACM2K	10.08.04	DL	Bear.	09.05.01	DL																															
				04	ACMRL	27.11.03	DL	Gep.	10.05.01	EH																															
				03	ACMRW	02.10.03	DL	Norm																																	
02	ACM2G	15.08.03	DL																																						
01	637f	16.04.03	DL																																						
Zeichnungsnummer / drawing No: Z-RK.6300.xxxx						Blatt sheet 1																																			
Zust. Änderung Datum Name Ursprung				Dateiname / File name: Z-R-6300-E.cdr																																					

## Connector assignment

### 5.4 Cabling instructions

#### Important rules when operating servo regulators and servomotors:

1. A radio interference suppression level cannot be maintained without an interference suppression filter at the line input. Moreover, line filter increase the immunity of the system to interference.
2. The cable between the power electronics and the motor must be shielded as YCY. A SY shield is not suitable. The shield support for the power cable (motor cable) must be on both ends. We recommend using SSD Drives motor cables K M BG xx – B!
3. Metal parts in the switching cabinet must be connected with each other having large areas of contact and must carry high frequencies very well. Avoid anodized, yellow-passivized and painted surfaces which can have very high resistance values based on the frequency! Make sure that the metals lie close together in the chemical circuit voltage class! Use the good conductivity and the large surface of the galvanized mounting plate as earth potential!
4. Relays, contactors and solenoid valves build into the same circuit must be connected with spark-suppressing combinations or components limiting over voltage, respectively. This applies also if these parts are not mounted in the same cabinet as the servo regulator.
5. The shield for the analog signal lines must be installed on one end and, if possible, in the switching cabinet. Ensure a connection which provides extensive contact and which is low-resistant! The shield for the digital signal lines must be installed on both ends, must have extensive contact and must be low resistance. An additional equalizer is to be laid parallel when there are potential differences. It is necessary to use plugs with metal enclosures with separable connections.
6. Avoid unnecessary extra loops on all connecting cables. All measures regarding filtering and shielding can be short circuited on them with high frequency. Connect unused litz wires in cables on both ends to the equipment ground conductor.
7. Unshielded cables of a circuit, the conductors going out and returning, should be twisted due to symmetrical interferences.
8. Separate physically "live" and "dead" wires even in the planning phase. Give special attention to the motor cables. The area of the common terminal strip-line input and motor output is especially endangered.
9. Relays, contactors and solenoid valves. The cables should be laid in the switching cabinet as close as possible to the ground; wires hanging freely in the air are preferred EMC victims as well as active and passive aeriels.
10. When operating with more than one line component in a common network, EMC problems are to be expected. From the start, the installation planner must integrate in his concept high frequency emitted interference as well as the electromagnetic susceptibility of the components to one another and take measures against it.
11. It is absolutely necessary to run cable shields completely up to the connectors. The connection of the cable shields to ground must be in the near field of the servo regulator (10 - 50 cm). Sensitive measuring leads should be removed as far as possible from this area; this applies also when they are shielded!
12. It is mandatory to run the motor cables in a separate cable channel and to lay flexible cable shielding also when these are shielded. This channel must be separated by at least 30 - 40 cm from the channel for the signal lines.

## Connector assignment

### 5.5 Plug designation

#### 5.5.1 Mating plugs for motor- and brake connections

Size	Plug designation
Y	only with wire-end ferrule
0...3	S MB G M2nRn 0/3

#### 5.5.2 Mating plugs for resolver- and thermal connection

Size	Plug designation
Y	PG – coupling
0...3	SIR

### 5.6 Cable designation

#### 5.6.1 Motor-cable

Size	Cable designation
Y...2	K MB R BG 0/2 – B K MB R BG 0/2 – B – LC*
3	K MB R BG 3 – B

#### 5.6.2 Resolver-cable

Size	Cable designation
Y...3	K IR – B K IR – B – LC*

\* LC = low cost cable



## 6 Technical data of the holding brake

### optional

holding brake	motor size	holding torque	max. current	moment of inertia	weight
Typ:	BG	M <sub>BrH</sub>	I <sub>max</sub>	J <sub>Br</sub>	m <sub>Br</sub>
	(-)	(Nm)	(A)	(kg cm <sup>2</sup> )	(g)
BR M BGY	<sup>1)</sup> Y	-	-	-	-
BR M BG0	<sup>1)</sup> 0	0,75	0,33	0,003	190
BR M BG1	1	3,20	0,42	0,030	445
BR M BG2	2	6,00	0,55	0,630	700
BBR M BG3	3	20,00	0,80	3,130	1040

<sup>1)</sup> Motor AC M2n0012 and AC M2n 0130 is not with holding brake equip !

<sup>2)</sup> New type of brake BBR is used off approx. in the middle of 2003!

Supply voltage:  $U_S = 24 \text{ V DC, } \pm 10\% \text{ acc. VDE 0580}$

Holding brakes are integrated on A- side; therefore the motor length is changed, see dimension K1 !

### The inserted brake is not characterized for the general slowing-down the drives, but is merely a standstill and/or holding brake.

Therefore, it must become guaranteed by the customer, that the drive stands, before that brake comes in. Should that brake not only become employed in the case of standing drives, so it's generally the wear and therefore the holding torque of the brake depending on:

- the speed of the drive with which the brake will be switched
- the load moment of inertia on the drive
- environmental conditions as temperature, and so forth.
- the number of braking and so forth

## 7 Shaft loads

### 7.1 Notation of definition

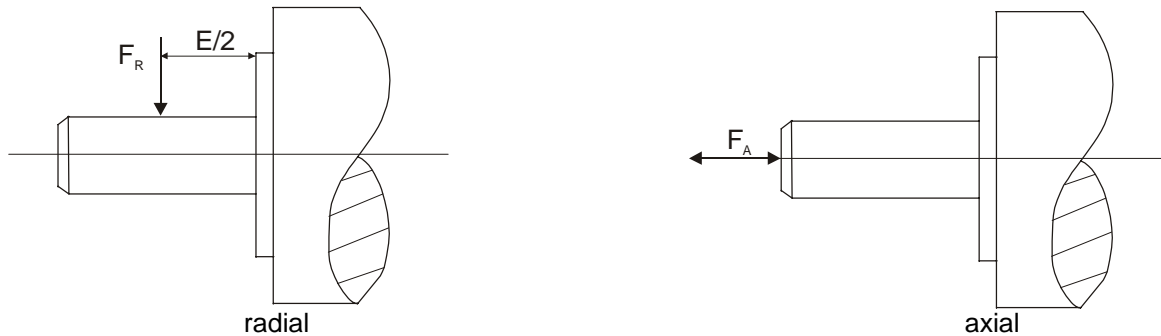

### 7.2 Technical dates of the max. radial $F_R$ (N) and axial $F_A$ (N) shaft load

Motor-Type	rated speed I	maximum radial shaft load	maximum axial shaft load
(-)	$n_n$ (1/min)	$F_R$ (N)	$F_A$ (N)
AC M2n 0012	6000	51	72
AC M2n 0010	4000	220 (138)	80 (33)
AC M2n 0030	4000	220 (155)	80 (33)
AC M2n 0045	4000	220 (163)	80 (33)
AC M2n 0070	4000	220 (169)	80 (33)
AC M2n 0130	4000	220 (175)	80 (33)
AC M2n 0055	4000	250 (156)	90 (45)
AC M2n 0090	4000	250 (171)	90 (45)
AC M2n 0150	4000	250 (181)	90 (45)
AC M2n 0220	4000	250 (189)	90 (45)
AC M2n 0290	4000	250 (195)	90 (45)
AC M2n 0320	4000	300 (333)	100 (71)
AC M2n 0480	4000	300 (346)	100 (71)
AC M2n 0650	4000	300 (362)	100 (71)
AC M2n 0830	4000	300 (391)	100 (71)
AC M2n 0960	4000	570 (383)	200 (83)
AC M2n 1200	4000	570 (398)	200 (83)
AC M2n 2000	4000	570 (427)	200 (83)

The values in bracket relate to simultaneous radial and axial shaft loads.

The specifications refers to 20000 hours of operation !

### 7.3 Use Ball bearing type

Motor-size	Ball bearing type	
	A-side	B-side
Y	607	607
0	6001	6001
1	6003	6001
2	6004	6002
3	6205	6004

## 8 Nominal power dependence of the SSD Drives AC servo motors concerning the installation altitude

### 8.1 Short description

When selecting an adequate motor the following is to be considered:

Workload (power), operating mode, starting, braking and by-passing processes, additional moment of inertia, moment course of the operating machine, speed control if necessary, net ratios, coolant temperature, installation altitude etc.

The nominal power is the power which is mechanically available at the shaft, if the installation site is not situated above 1000 m MSL, the air temperature does not exceed 40° C, and the net ratios are normal.

With deviating conditions concerning installation altitude and air temperature, the permissible power must be corrected corresponding to the following picture.

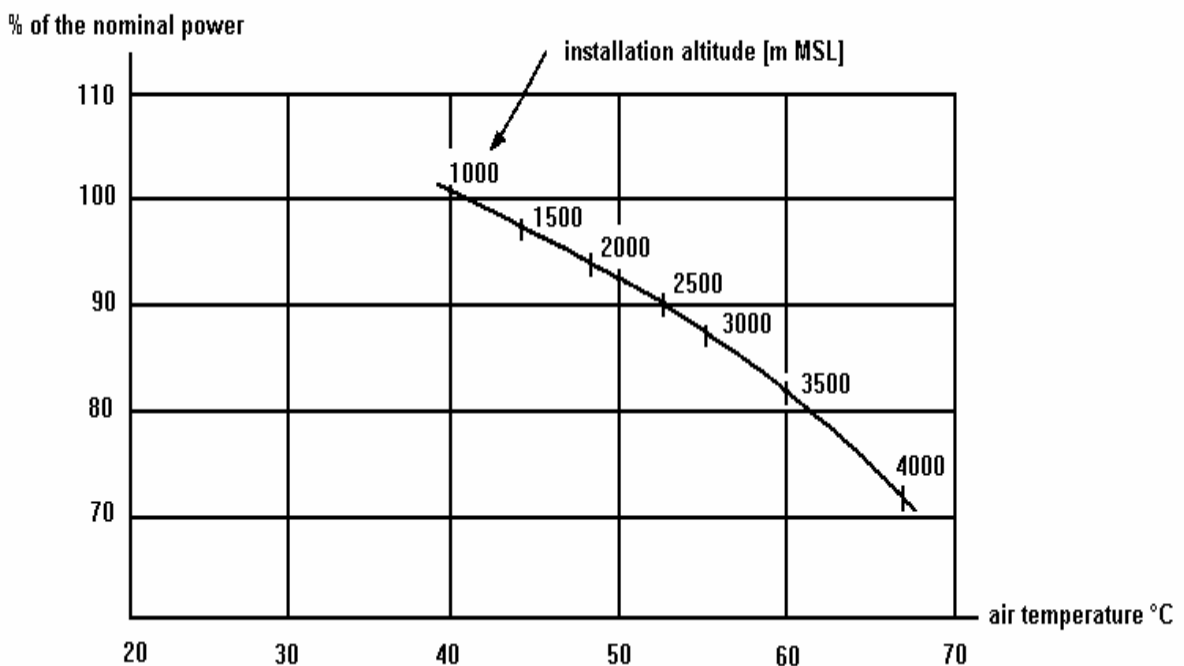

Check the air temperature and the installation altitude separately. Should there be different air temperatures and installation altitude at the same time, the factors for the permissible power must be multiplied.

## 9 Certificates



### Standard Specifications and Certifications Manufacturer's Declaration

In accordance with the EC – Machinery Directive 89/392/EEC  
Annex II B approximation of the regulation of the member states for machinery.

The following Products

AC – Servo - motors of series

**AC M2n, AC M2K, AC MHx, AC M2G and AC G**

in standard design are components to be incorporated into machinery and may not be operated alone. The complete machinery or installation using this equipment may only be put into service when the safety considerations of the Directive 89/3892/EEC are fully adhered to.

The above mentioned products are in accordance with the relevant clauses from the following standards.

**Basic directives:**

- EN 60034 / VDE 0530
- IEC 34 – 1,5,6,8,9,14 / IEC 72 / IEC 85
- VDE 0100, VDE 0110, VDE 0530-1
- EC – MASCHINERY DIRECTIVE 89/392/EEC
- EC – LOW VOLTAGE DIRECTIVE 73/23/EEC

CE – Lable  
as standard on the name plate.

Issuer:

SSD Drives GmbH  
Im Sand 14  
76669 Bad Schönborn

Bad Schönborn, 01.11.2004

Legally binding signature



ppa. Erich Ehlen  
Plant Manager

This declaration does not include any assertion of properties. The references for safety and protection (operating instruction) are to observe in every case keep.



## 11 Modification Record

Version	Modification	Chapter	Date	Name	Comment
V01.39EHST99	New !		06.10.1999	K.Stadler	
V02.51DL00	New speed diagrams New technical data	2.1 2	22.12.2000	N.Dreilich	
V0301	Separation German / English	all	01.02.2001	N.Dreilich	
V0401	Layout Technical data size Y Connector Cable designation Certificates	1.3 3 4 5.1 – 5.3 5.6 9	08.02.2002	N.Dreilich	changed correction/new new changed/new new new
V0503	Type code Technical data Torque/Speed Diagrams Connector assignment PG gland Technical data of the holding brake Shaft loads Technical data Notes	1.2 3 3.1 - 3.1.4 5.1 6 7 7.2 10	27.08.2002	N.Dreilich	complete correction new design new correction / new new Layout correction insert
V0604	SSD Drives	-	18.10.2004	N.Dreilich	LOGOS

**AUSTRALIEN**  
**Eurotherm Pty Ltd**  
Unit 1  
20-22 Foundry Road  
Seven Hills  
New South Wales 2147  
Tel: +61 2 9838 0099  
Fax: +61 2 9838 9288

**CHINA**  
**Eurotherm Pty Ltd**  
Apt. 1805, 8 Building Hua Wei Li  
Chao Yang District,  
Beijing 100021  
Tel: +86 10 87785520  
Fax: +86 10 87790272

**DÄNEMARK**  
**Eurotherm GmbH**  
Enghavevej 11  
DK-7100 Vejle  
Tel: +45 70 201311  
Fax: +45 70 201312

**DEUTSCHLAND**  
**SSD DRIVES GmbH**  
Von-Humboldt-Straße 10  
64646 Heppenheim  
Tel: +49 6252 7982-00  
Fax: +49 6252 7982-05

**ENGLAND**  
**SSD Drives Ltd**  
New Courtwick Lane  
Littlehampton  
West Sussex BN17 7RZ  
Tel: +44 1903 737000  
Fax: +44 1903 737100

**FRANKREICH**  
**SSD Drives SAS**  
15 Avenue de Norvège  
Villebon sur Yvette  
91953 Courtaboeuf Cedex / Paris  
Tel: +33 1 69 185151  
Fax: +33 1 69 185159

**HONG KONG**  
**Eurotherm Ltd**  
Unit D  
18/F Gee Chang Hong Centre  
65 Wong Chuk Hang Road  
Aberdeen  
Tel: +852 2873 3826  
Fax: +852 2870 0148

**INDIEN**  
**Eurotherm DEL India Ltd**  
152, Developed Plots Estate  
Perungudi  
Chennai 600 096, India  
Tel: +91 44 2496 1129  
Fax: +91 44 2496 1831

**IRLAND**  
**SSD Drives**  
**2004/4 Orchard Ave**  
Citywest Business Park  
Naas Rd, Dublin 24  
Tel: +353 1 4691800  
Fax: +353 1 4691300

**ITALIEN**  
**SSD Drives SpA**  
Via Gran Sasso 9  
20030 Lentate Sul Seveso  
Milano  
Tel: +39 0362 557308  
Fax: +39 0362 557312

**JAPAN**  
**PTI Japan Ltd**  
7F, Yurakucho Building  
10-1, Yuakucho 1-Chome  
Chiyoda-ku, Tokyo 100-0006  
Tel: +81 3 32132111  
Fax: +81 3 32131900

**KANADA**  
**SSD Drives Inc**  
880 Laurentian Drive  
Burlington  
Ontario  
Canada, L7N 3V6  
Tel: +1 905 333-7787  
Fax: +1 905 632-0107

**KOREA**  
**Myungshin Drives Co. Ltd.**  
1308, Daeryung Techno Town  
8th Bldg., 481-11 Gasan-Dong,  
Geumcheon-Gu,  
Seoul 153-803  
Tel: +82 2 2163 6677  
Fax: +82 2 2163 8982

**NIEDERLANDE**  
**Eurotherm BV**  
Genielaan 4  
2404CH  
Alphen aan den Rijn  
Tel: +31 172 411 752  
Fax: +31 172 417 260

**POLEN**  
**OBR-USN**  
ul. Batorego 107  
PL 87-100 Torun  
Tel: +48 56 62340-21  
Fax: +48 56 62344-25

**RUMÄNIEN**  
**Servosisteme SRL**  
**Sibiu 17**  
061535 Bukarest  
Tel: +40 723348999  
Fax: +40 214131290

**SPANIEN**  
**Eurotherm Espana S.A.**  
Pol. Ind. Alcobendas  
C/ La Granja, 74  
28108 Madrid  
Tel: +34 91 661 60 01  
Fax: +34 91 661 90 93

**SCHWEDEN**  
**SSD Drives AB**  
Montörgatan 7  
S-30260 Halmstad  
Tel: +46 35 177300  
Fax: +46 35 108407

**SCHWEIZ**  
**Indur Antriebstechnik AG**  
Margarethenstraße 87  
CH 4008 Basel  
Tel: +41 61 27929-00  
Fax: +41 61 27929-10

**U.S.A**  
**SSD Drives Inc.**  
9225 Forsyth Park Drive  
Charlotte  
North Carolina 28273-3884  
Tel: +1 704 588 3246  
Fax: +1 704 588 3249

Weitere Niederlassungen und Vertretungen in:

Ägypten · Argentinien · Bangladesch · Brasilien · Chile · Costa Rica · Ecuador · Griechenland · Indonesien · Island · Israel  
Kolumbien · Kuwait · Litauen · Malaysia · Marokko · Mexico · Neuseeland · Nigeria · Peru · Philippinen · Portugal  
Österreich · Saudi Arabien · Singapur · Slowenien · Sri Lanka · Süd Afrika · Taiwan · Thailand · Tschechien  
Türkei · Ungarn · Vereinigte Arabische Emirate · Vietnam · Zypern

## SSD Drives GmbH

Im Sand 14 76669 Bad Schönborn Tel.: +49 7253 9404-0, Fax: +49 7253 9404-99  
www.ssddrives.com · ssd@ssddrives.de