

Turnkey Turntable
Drive Solution
MSR Range

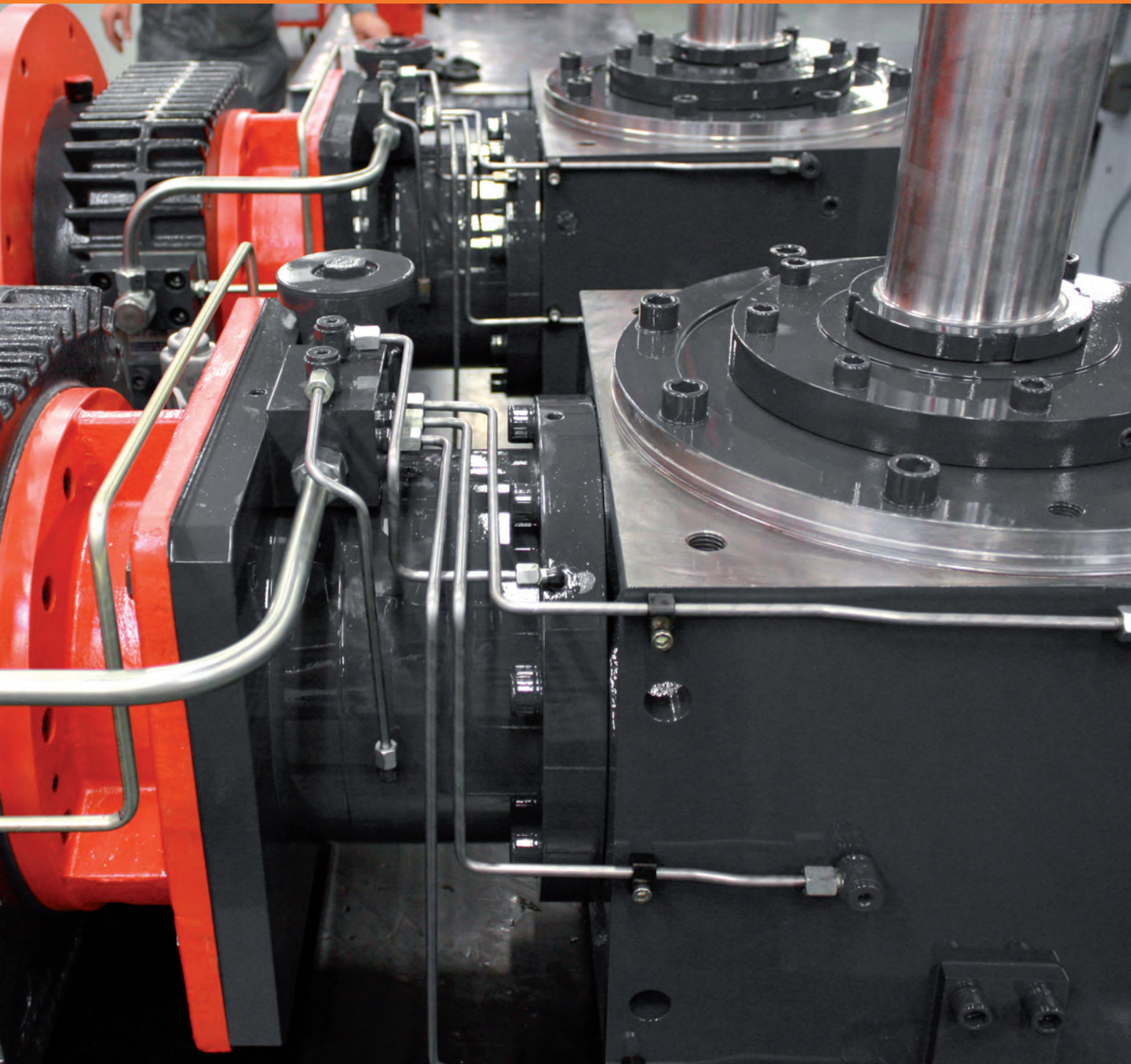

MSR Range

Two Speed Gearbox for VTL

State-of-the art technology

The traditional solution for turn table drive is composed of a main drive (single pinion) for turning operation plus a preloaded gearbox (Dual pinions) for C axis milling operation. This configuration is complex and expensive.

Power sharing and very high positioning accuracy

REDEX designers have introduced on the market an innovative solution taking advantage from the latest CNC technology.

Two identical gearboxes (Twin pinions) share the driving torque (50%-50%) during turning operations and work in preload mode when C axis is required (milling operation). Gear ratio shifting allows to cover the full range of speed: high-speed for turning and low speed for milling.

Full load is available during turning and backlash is cancelled during milling !

A cost effective solution

The **MSR Drive** is a complete machine-tool subassembly, ready to use and fully tested. It is an integrated and compact system that dramatically simplifies VTL tables kinematics and allows high-performance in terms of speed range and accuracy.

The **MSR** range consists of 4 sizes (330, 640, 650 and 660) with torque capacity per pinion from 2500 Nm up to 12000 Nm with several standard ratios and options available.



Turnkey Turntable Drive Solution

MSR 330

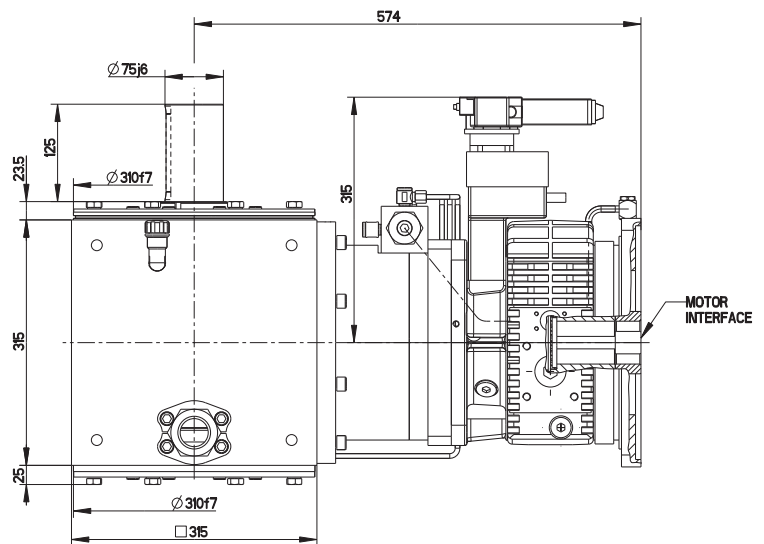
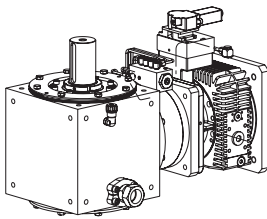

Dimensions and main data for information only, please refer to Product Datasheet

MODEL	Plain Shaft			
			MSR 334	MSR 336
High speed ratio	i1	-	2.00	2.00
Low speed ratio	i2	-	9.88	7.66
Rated output torque	T2N	[Nm]	2500	2500
Max. input speed	N1B	[rpm]	6000	6000
Efficiency	η	[%]	94	94
Weight	m	[kg]	280	280

REDEX

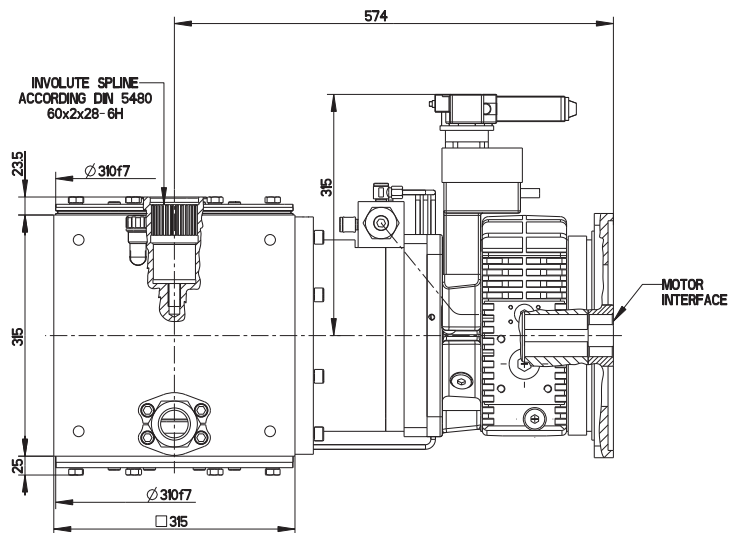
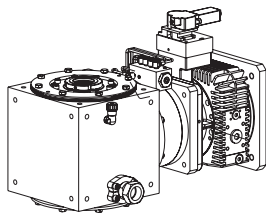
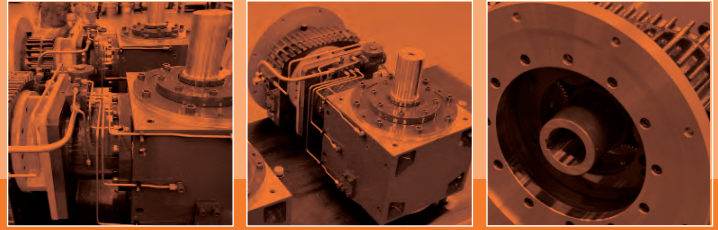

Dimensions and main data for information only, please refer to Product Datasheet

MODEL	Hollow Shaft			
			MSR 334	MSR 336
High speed ratio	i1	-	2.00	2.00
Low speed ratio	i2	-	9.88	7.66
Rated output torque	T2N	[Nm]	2500	2500
Max. input speed	N1B	[rpm]	6000	6000
Efficiency	η	[%]	94	94
Weight	m	[kg]	276	276

Turnkey Turntable Drive Solution

MSR 640

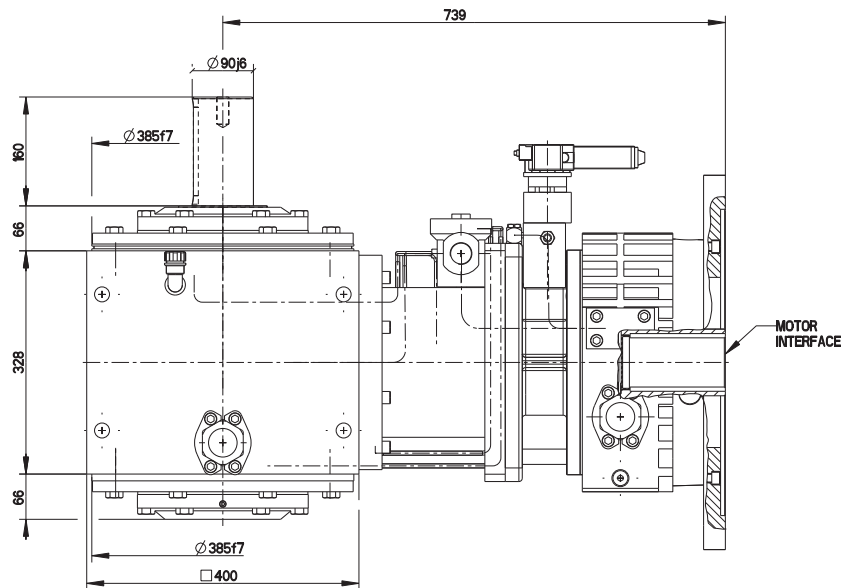
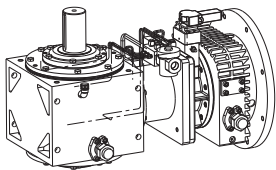

Dimensions and main data for information only, please refer to Product Datasheet

MODEL	Plain Shaft			
			MSR 644	MSR 646
High speed ratio	i1	-	2.00	2.00
Low speed ratio	i2	-	9.88	7.66
Rated output torque	T2N	[Nm]	5900	7000
Max. input speed	N1B	[rpm]	5000	5000
Efficiency	η	[%]	94	95
Weight	m	[kg]	548	548

REDEX

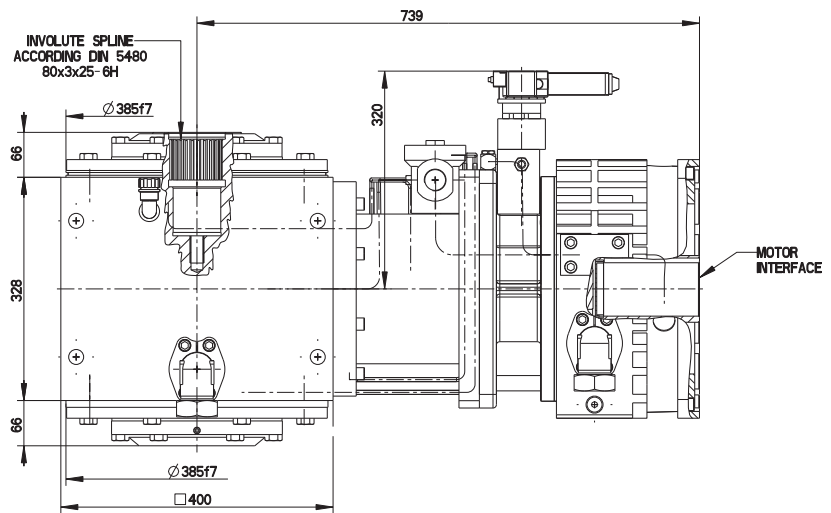
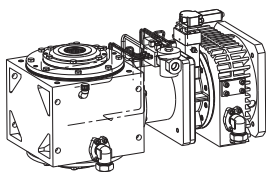
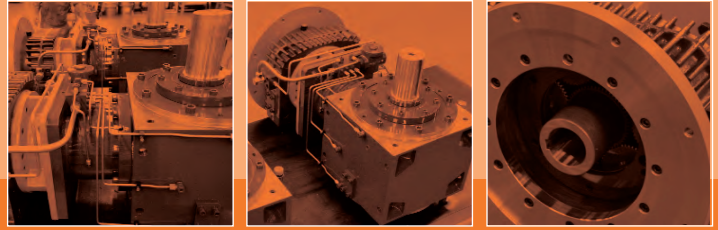

Dimensions and main data for information only, please refer to Product Datasheet

MODEL	Hollow Shaft			
			MSR 644	MSR 646
High speed ratio	i1	-	2.00	2.00
Low speed ratio	i2	-	9.88	7.66
Rated output torque	T2N	[Nm]	5900	7000
Max. input speed	N1B	[rpm]	5000	5000
Efficiency	η	[%]	94	94
Weight	m	[kg]	540	540

REDEX

Turnkey Turntable Drive Solution

MSR 650

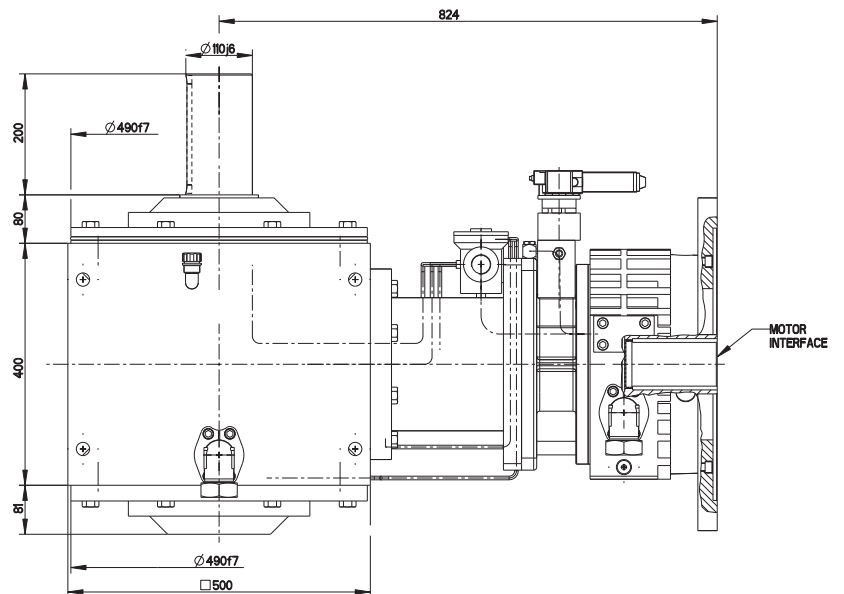
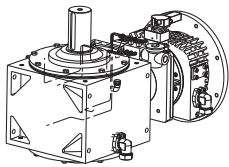

Dimensions and main data for information only, please refer to Product Datasheet

MODEL	Plain Shaft			
			MSR 654	MSR 656
High speed ratio	i1	-	2.26	2.26
Low speed ratio	i2	-	11.16	8.66
Rated output torque	T2N	[Nm]	6600	9000
Max. input speed	N1B	[rpm]	4500	4500
Efficiency	η	[%]	94	94
Weight	m	[kg]	750	750

REDEX

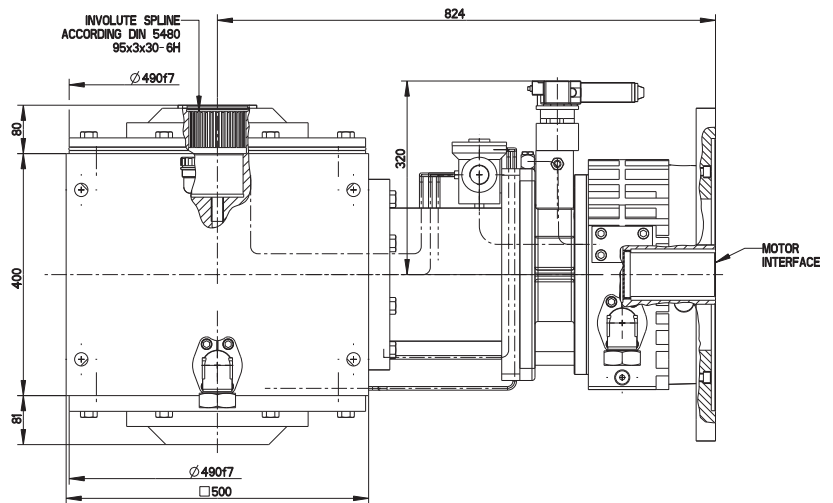
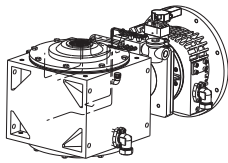
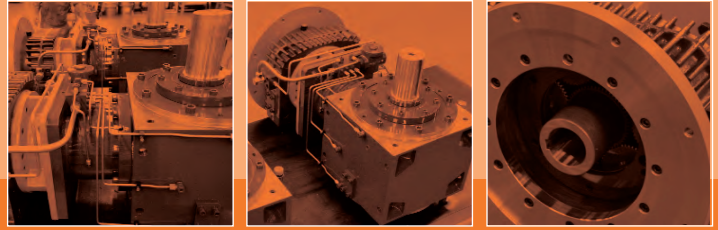

Dimensions and main data for information only, please refer to Product Datasheet

MODEL	Hollow Shaft			
			MSR 654	MSR 656
High speed ratio	i1	-	2.26	2.26
Low speed ratio	i2	-	11.16	8.66
Rated output torque	T2N	[Nm]	6600	9000
Max. input speed	N1B	[rpm]	4500	4500
Efficiency	η	[%]	94	94
Weight	m	[kg]	740	740

REDEX

Turnkey Turntable Drive Solution

MSR 660

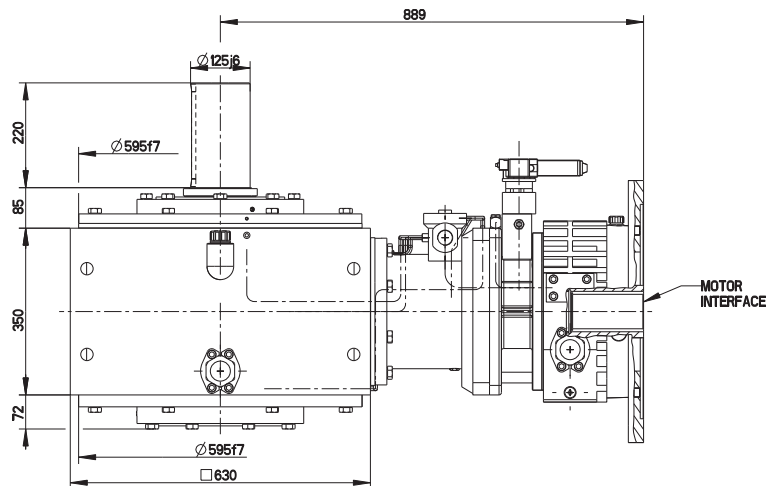
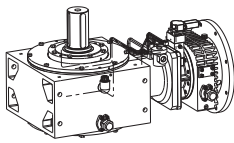

Dimensions and main data for information only, please refer to Product Datasheet

			Plain Shaft
MODEL			MSR 666
High speed ratio	i1	-	3.00
Low speed ratio	i2	-	11.49
Rated output torque	T2N	[Nm]	12000
Max. input speed	N1B	[rpm]	3500
Efficiency	η	[%]	94
Weight	m	[kg]	1400

REDEX

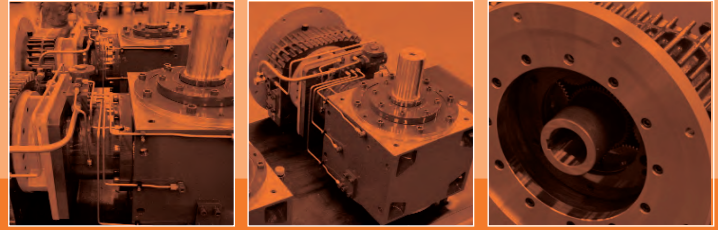

REDEX

REDEX is the market leader in one of the critical function of machine-tools: linear, rotation and spindle drives.

REDEX was created in 1949 from a patented process based on the thermoplastic clamping of central parts of a planetary gearbox system able to dramatically increase the torque/volume ratio. The famous "REDEX pulley" therefore became the companion of three generations of engineers ...

Sixty years later REDEX made this taste for innovation the mainspring of its international development as a key partner of leading machine manufacturers around the world.

REDEX success relies on :

- > Bringing innovative design solution with a significant commitment to R&D.
- > Achieving top product quality through world class manufacturing, assembly and testing facilities.
- > Offering local service, support and training through a unique network of highly trained application engineers worldwide and 3 service centers in Europe, Asia and America.

REDEX dedication to the machine-tool market is the key of its success, a company passionate for machine building, creating solutions for your success.



REDEX

info@machine-tool-drives.com
www.machine-tool-drives.com

REDEX
The Machine-Tool Drives Company