

## CONTENTS

### SOMMAIRE DETAILLE

#### Z SERIES - Spiral Bevel Gearboxes

The universal design

The Z-Series product line offers 7 different sizes, 6 model types, and 9 ratios, with various input-output arrangements including solid shaft or hollow bore options, as well as universal mounting capability.

All of these options are made possible by a modular design concept that starts with a cubic housing.

The Z-Series is an extremely versatile product line, meeting virtually all of the technical office requests.

#### SERIES Z - Renvois d'Angle Spiro-coniques

La gamme universelle

La famille des renvois d'angles Série Z offre 7 tailles, 6 modèles et 9 rapports, combinés avec de multiples interfaces d'entrée-sortie, (choix entre arbre ou alésage, flasque...) qui permettent une très grande variété de montage.

La disponibilité de ces nombreuses options est liée à une conception résolument modulaire dont la base est le bâti cubique de l'appareil.

La série Z constitue une ligne de produits extrêmement polyvalente, qui répond à pratiquement tous les besoins que peuvent exprimer les bureaux d'étude.

OVERVIEW	7	PRESENTATION	7
SHAFT ARRANGEMENT & DIRECTION OF ROTATION	10	TYPES D'ENTREES - SORTIES & SENS DE ROTATION	10
MOUNTING POSITION & MOUNTING SURFACE	11	POSITION & FACES DE FIXATION	11
SIZING PRINCIPLE	12	PRINCIPE DE SELECTION	12
LUBRICATION, COOLING	13	LUBRIFICATION, REFROIDISSEMENT	13
SEALING	14	ETANCHEITE	14
SIZING & ORDERING CODE	15	SELECTION & CODIFICATION	15
AXIAL & RADIAL LOADS	16	CHARGES AXIALES & RADIALES	16
INERTIA, STIFFNESS	17	INERTIES, RAIDEURS	17
POWER & TORQUE RATING TABLES Z	18	PUISSANCES ET COUPLES NOMINAUX Z	18
POWER & TORQUE RATING TABLES ZT	23	PUISSANCES ET COUPLES NOMINAUX ZT	23
DIMENSIONS Z	24	ENCOMBREMENTS Z	24
DIMENSIONS ZT	31	ENCOMBREMENTS ZT	31
POWER & TORQUE RATING TABLES ZI-ZD	36	PUISSANCES ET COUPLES NOMINAUX ZI-ZD	36
DIMENSIONS ZI-ZD	38	ENCOMBREMENTS ZI-ZD	38
OTHER FLANGES DIMENSIONS	43	GAMME DE FLASQUES MOTEUR	43
TYPE ZX TRI-DIRECTIONAL	44	TABLEAU ZX	44
FILL, LEVEL & DRAIN POSITION	45	POSITION DES ORIFICES	45
SPARE PARTS	48	PIECES DETACHEES	48



### OVERVIEW PRESENTATION

Z Series Série Z

Z Series : universal cubic design

The family of Z Series bevel gearboxes offers a wide range of different sizes and types, which can be combined with many different input-output interfaces. This allows a wide variety of mounting configurations. The motion transmission is available in 2 or 3 different axes.

Their modular design offers many additional functions such as reducer, multiplier, reversing, freewheel, or special bearing arrangements. In addition, the Z-Series gearboxes can be ATEX certified on request.

In addition to top quality gears, the large range of lubrication, sealing and cooling options, gives the guarantee of very long life, even in heavy duty working conditions.

Série Z : la conception universelle autour d'une base cubique

La famille des renvois d'angles Série Z offre un très large choix de tailles et de modèles différents, qui se combinent avec de multiples interfaces d'entrée-sortie pour permettre une très grande variété de montages.

Le mouvement peut se transmettre suivant 2 ou 3 axes distincts.

Leur conception modulaire permet aussi de bénéficier de nombreuses fonctions supplémentaires telles que réducteur, multiplicateur, inverseur, débrayage ou boîte palière.

La très haute qualité des engrenages utilisés, mais aussi les options variées en matière de lubrification, étanchéité ou refroidissement, permettent de garantir des durées de vie très élevées dans des conditions de fonctionnement sévères.

La série Z, certifiée ATEX sur demande, constitue une ligne de produits extrêmement polyvalente, qui répond à pratiquement tous les besoins que peuvent exprimer actuellement les bureaux d'étude.

#### Z - ZR - ZX

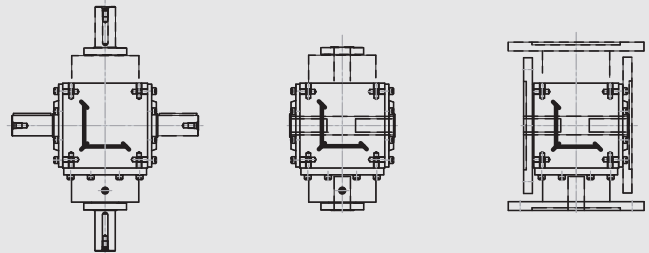

#### ZT

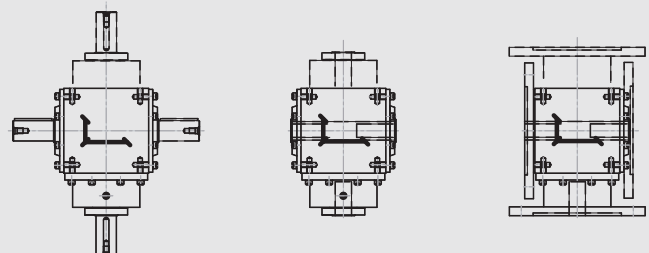

#### ZD - ZI

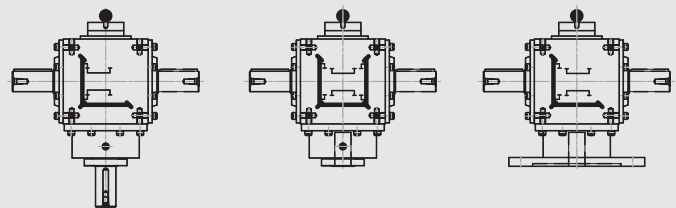

Input-Output shaft options :

- Solid shafts
- Hollow bores
- Hollow bores & Motor flanges

Housing dimensions are the same irrespective of gear ratios.

Options d'interfaces Entrée-Sortie disponibles:

- Arbres pleins
- Arbres creux
- Arbres creux & Flasques brides moteurs

Les dimensions de la base cubique des appareils sont identiques, quels que soient les rapports de réduction.

## OVERVIEW PRESENTATION

### HIGH QUALITY DESIGN AND MANUFACTURE

#### Large range of gear ratios

For use as reducer or multiplier

#### Spiral bevel gears

Case hardened alloy steel. Gears are shrunk fit onto shaft to eliminate key fretting  
HPG-S (Klingelberg) gear cutting and finishing technology on request, offering the combined benefits of heavy duty, low noise and very long life.

#### Low Backlash and transmission error

As low as 3 arc.min on request (\*)

#### Efficiency of 95 - 99 %

Fully reversible direction of rotation

#### Taper Roller bearings

High radial and axial load capacity combined with high torsional rigidity

#### Standard sealing with Viton(\*\*) seals

High speed / high temperature - Single or double seals - with or without dust lip

#### Special sealing

Labyrinth seals available : no maintenance, higher speed, better efficiency, lower temperature inside and outside.

#### Special cooling

Compliance with ATEX standards on request

#### CAD files available on request (DXF)

(\*) except for size Z08

(\*\*) registered trademark of E.I. DuPont Co

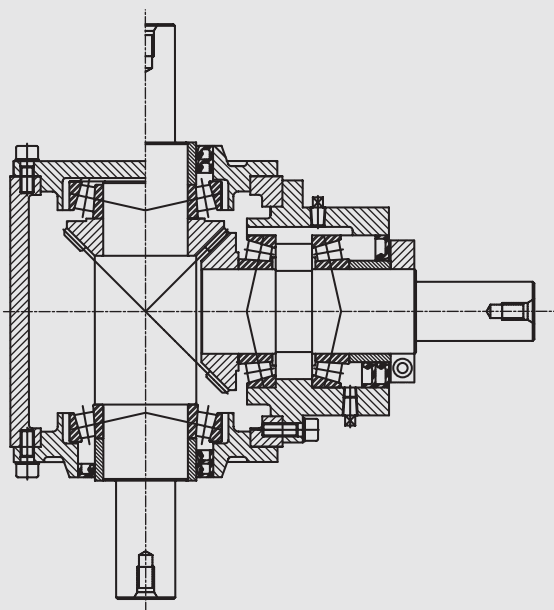
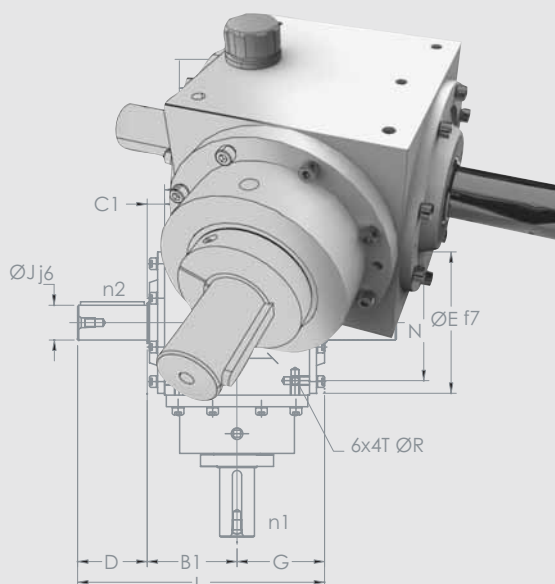

### CONCEPTION ET FABRICATION DE HAUTE QUALITE

#### Large gamme de rapports de réduction

Utilisation comme réducteur ou Multiplicateur

#### Engrenages spiro-coniques

Acier allié cémenté-trempé. Les pignons sont frettés sur les arbres pour éviter tout risque de déformation des clavette. Le taillage de pignons en qualité HPG-S (Klingelberg) est disponible sur demande pour permettre d'améliorer à la fois la capacité de charge, de diminuer le niveau de bruit et pour augmenter la durée de vie.

#### Jeu angulaire réduit et très bon homocinétisme

Jeu angulaire réduit à 3' d'arc sur demande (\*)

#### Rendement de 95 à 99 %

Réversibilité totale du mécanisme

#### Roulements à rouleaux coniques

Capacité de charges radiales et axiales élevées, ainsi qu'une grande rigidité torsionnelle

#### Niveau d'étanchéité standard réalisé à base de joints Viton(\*\*)

Haute vitesse et haute température - Joint simple ou double joint - avec ou sans lèvres anti-poussière

#### Étanchéité spéciale

Une version spéciale "sans joints" est disponible en standard : maintenance extrêmement réduite, haute vitesse, meilleur rendement, température plus faible à l'intérieur et à la surface des appareils

#### Rafroidissement spéciaux

Certification ATEX sur demande

#### Fichiers CAO / DAO disponibles sur demande (DXF)

(\*) sauf taille Z08

(\*\*) marque déposée de E.I. DuPont Co



OVERVIEW  
PRESENTATION

Z Series Série Z

**HIGHLY VERSATILE CONCEPT**

**Cubic Cast iron housing**

Machined for mounting on all six faces

**Alternative mounting solutions**

Using the motor flanges, or with additional plates

**Same external dimensions irrespective of ratio**

(except shaft n1)

**Same pilot diameter on mounting faces n1 and n2**

**Six different type derivatives**

- Z : universal design, with standard or labyrinth seals
- ZR : reinforced shaft n2
- ZT : pinion on through shaft n2 (multiplier)
- ZI : manual forward, neutral & reverse
- ZD : manual slide dog clutch
- ZX : 3 axis version of the Z series

**Fully reversible**

Similar properties irrespective of rotation direction

**VERY LARGE RANGE**

**Maximum torque up to 4000 Nm**

**Maximum transmissible power up to 360 kW**

**Maximum speed**

- Up to 3000 RPM with standard seals
- Up to 5500 RPM with labyrinth seals

**7 different sizes**

- Cubic frame dimension from 80 x 80 mm (size 08), to 315 x 315 (size 31)
- 3 types for size 08 : Z - ZT - ZX
- 5 types for size 10 to 31 : Z - ZT - ZX - ZI - ZD
- 1 type for size 12 to 31 : ZR
- Labyrinth seal version available for sizes 16 to 31

**9 standard ratios**

- 9 ratios (0.8 - 1 - 1.25 - 1.5 - 2 - 3 - 4 - 5 - 6) for types Z and ZR, including the labyrinth seal versions
- 2 ratios (0.5 - 0.666) for type ZT (multiplier)
- 5 ratios (1 - 1.25 - 1.5 - 2 - 3) for types ZI and ZD
- 7 ratios (1.25 - 1.5 - 2 - 3 - 4 - 5 - 6) for type ZX

Customized ratios, shaft shape, and motor flanges on request.

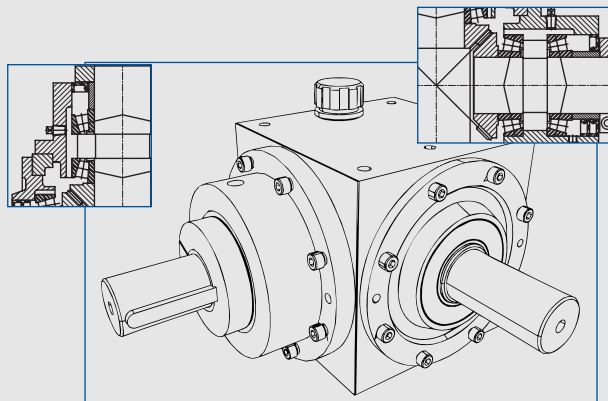

**UN CONCEPT EXTREMEMENT POLYVALENT**

**Carter cubique en fonte de haute qualité**

Usiné sur l'ensemble de ses faces pour permettre la fixation quelque soit l'orientation choisie

**Modes de fixation complémentaires**

Fixation par les flasques moteur ou grâce à des plaques d'adaptation

**Encombrement identique pour tous les rapports**

(sauf arbre n1)

**Centrages pour la fixation identiques sur les côtés n1 et n2**

**Nombreux modèles différents autour du modèle de base**

- Z : modèle de base, universel, qui inclut la version spéciale "sans joints"
- ZR : arbre n2 renforcé
- ZT : arbre rapide traversant (multiplicateur)
- ZI : arbre n2 débrayable, inverseur de rotation et point mort
- ZD : arbre n2 débrayable et point mort
- ZX : version tridirectionnelle de la série Z

**Fonctionnement entièrement réversible**

L'ensemble des propriétés est conservée, quel que soit le sens de rotation utilisé

**UNE GAMME TRES ETENDUE**

**Couple maximum en sortie : 4000 Nm**

**Puissance transmissible maximum : 360 kW**

**Vitesse de rotation maximum**

Jusqu'à 3000 min<sup>-1</sup> pour les versions avec joints d'étanchéité  
Jusqu'à 5500 min<sup>-1</sup> pour les versions "sans joints"

**7 tailles différentes**

- Dimensions du bâti cubique comprises entre 80 x 80 mm (taille 08), et 315 x 315 mm (taille 31)
- 3 modèles disponibles en taille 08 : Z - ZT - ZX
- 5 modèles disponibles en tailles 10 à 31 : Z - ZT - ZX - ZI - ZD
- 1 modèle disponibles en tailles 12 à 31 : ZR
- Les versions "sans joints" sont disponibles en tailles 16 - 20 - 25 - 31

**9 rapports de réduction standards**

- 9 rapports disponibles (0.8 - 1 - 1.25 - 1.5 - 2 - 3 - 4 - 5 - 6) pour les types Z et ZR, y compris les versions "sans joints"
- 2 rapports disponibles (0.5 - 0.666) pour le type ZT (multiplicateur)
- 5 rapports disponibles (1 - 1.25 - 1.5 - 2 - 3) pour les types ZI et ZD
- 7 rapports disponibles (1.25 - 1.5 - 2 - 3 - 4 - 5 - 6) pour le type ZX

Rapports hors standards, arbres pleins ou creux et flasques brides spéciaux sur demande

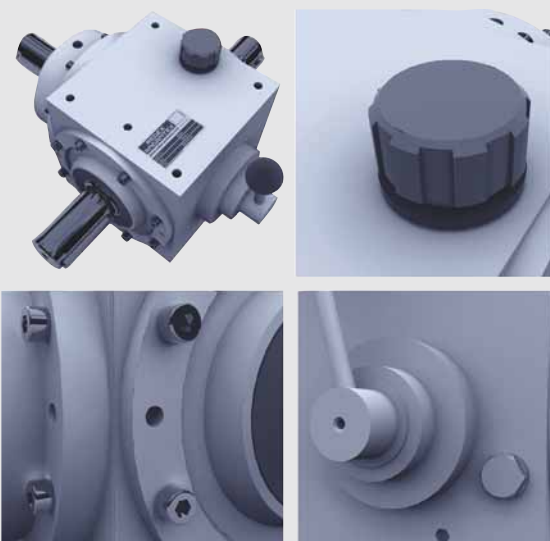

## SHAFT ARRANGEMENT & DIRECTION OF ROTATION TYPES D'ENTREES - SORTIES & SENS DE ROTATION

### SHAFT ARRANGEMENT LETTER CODE

Letters in box designates chosen shaft extension, type, and location.

Note : shaft letters must follow alphabetical order

ex : CF ~~FC~~  
EWHB BEHW

- 1 C, F, J, Y : solid shaft
- 2 B, E, H, W : hollow bore, keyed  
or K, L, N, P : hollow bore, splined
- 3 A, D, G, V : hollow bore, keyed + motor flange  
or M, R, S, T : hollow bore, splined + motor flange

### CODIFICATION DES TYPES D'ENTREES/SORTIES

Les lettres encadrées indiquent les types et les positions correspondant aux interfaces choisies.

Nota : l'ordre des lettres doit suivre l'ordre alphabétique.

ex : CF ~~FC~~  
EWHB BEHW

- 1 C, F, J, Y : arbres pleins
- 2 B, E, H, W : arbres creux clavetés  
ou K, L, N, P : arbres creux-cannelés
- 3 A, D, G, V : arbres creux clavetés + flasque bride  
ou M, R, S, T : arbres creux cannelés + flasque bride

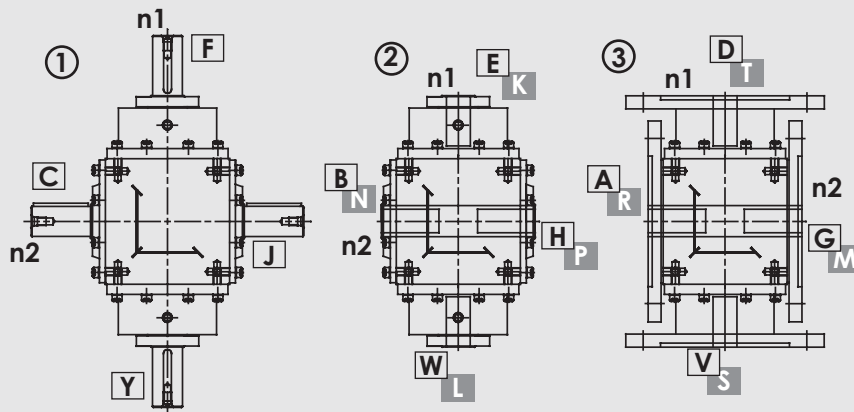

### DIRECTION OF ROTATION LETTER CODE

Opposite letters ( O / I ) designate relative direction of rotation

Note : direction of rotation is fully reversible

### CODIFICATION DU SENS DE ROTATION

Les lettres ci-contre ( O / I ) indiquent le sens de rotation relatif des sorties entre-elles.

Nota : le sens de rotation est totalement réversible

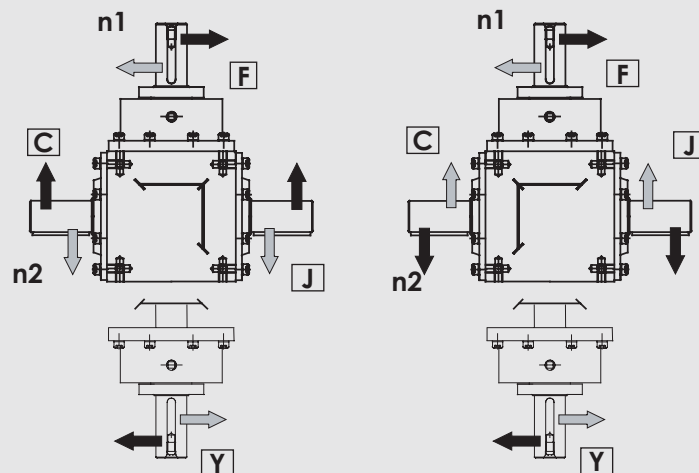

Rotation O

O n2, n1 : same direction of rotation

I n2, n1 : opposite direction of rotation

Rotation I

O n2, n1 : sens de rotation identique

I n2, n1 : sens de rotation inversé

All data subject to change without notice  
Données susceptibles d'être modifiées sans préavis

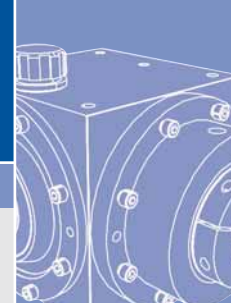

## MOUNTING POSITION & MOUNTING SURFACE POSITION & FACES DE FIXATION

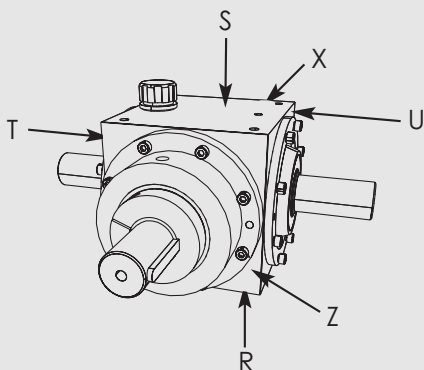

### Position designation

The sketches below and opposite are shown with respect to the floor. Mounting position & mounting surface are required to locate the oil fill, level and drain, as well as to select the surfaces to be painted.

### Indication des positions

Les schémas ci-contre et ci-dessous sont dessinés par rapport à l'horizontale.

La spécification de la position de fonctionnement et de la face de fixation sont impératives pour permettre la localisation des orifices (remplissage, niveau et vidange), ainsi que pour la définition des surfaces qui peuvent ou non être peintes.

### MOUNTING SURFACE / FACE DE FIXATION

	R	S	T	U	X	Z
K						
L						
M						
N						
P						

ex. : fixed on the upper surface, with horizontal shafts → **KS** (line K, column S)  
 fixation par la face supérieure avec le plan des axes à l'horizontale → **KS** (ligne K, colonne S)

**Note :** it is recommended to use only mounting position K for labyrinth seal versions.  
 For other mounting positions, please contact your local supplier.

**Nota :** il n'est pas recommandé de prévoir d'autre position de fonctionnement que celle repère K pour les modèles avec étanchéité spéciale "sans joints".  
 En cas de nécessité, contacter votre revendeur local.

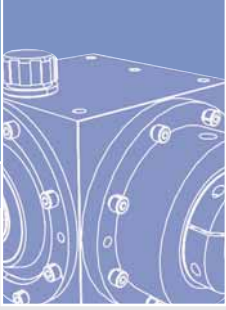

### SIZING PRINCIPLE MODE DE SELECTION

#### REQUIRED DATA

- Absorbed power **P1**
- Speed **n1** and **n2**
- Duty cycle (see tables **Ka** and **Ki**)

Design Power (P) is given by the formula :

$$P = P1 \times Ka \times Ki$$

Select the units so that the power shown on the rating tables is greater than the result **P**

#### DONNEES TECHNIQUES REQUISES

- Puissance absorbée **P**
- Vitesses **n1** et **n2**
- Conditions d'utilisation (**Ka** et **Ki**)

La puissance utile corrigée (P) est donnée par la formule :

$$P = P1 \times Ka \times Ki$$

Le choix des appareils doit être tel que la puissance indiquée dans les tables demeure toujours supérieure au résultat **P**

#### SERVICE FACTOR FACTEUR DE SERVICE

**Ka**

	Uniform load Charge uniforme	Moderate shock Surcharges modérées	Heavy shock Surcharges importantes
Electric motor Moteur électrique	1.00	1.25	1.50
Diesel engine Moteur thermique	4 / 6 cyl. 1 / 3 cyl.	1.25 1.50	1.50 2.25

#### SERVICE LIFE FACTOR COEFFICIENT DE DUREE DE VIE

**Ki**

Hours Heures	100	1000	5000	10000	15000	20000	40000
<b>Ki</b>	0.65	0.8	0.95	1	1.05	1.15	1.4

#### Example of selection Exemple de sélection

- Absorbed power **P1** = 9Kw (1000 min<sup>-1</sup>)
- Prime mover : electric motor with speed **n1** = 1000 min<sup>-1</sup>
- Uniform load (no shock), **Ka** = 1 (above table)
- Required min. life = 5000h, **Ki** = 0.95 (above table)
- Ratio **i** = 1
- Efficiency = 98%

- Puissance absorbée **P** = 9Kw (1000 min<sup>-1</sup>)
- Motorisation : moteur électrique, vitesse **n1** = 1000 min<sup>-1</sup>
- Fonctionnement uniforme, donc **Ka** = 1 (tableau ci-dessus)
- Durée de vie min. de 5000h, donc **Ki** = 0.95 (tableau ci-dessus)
- Rapport **i** = 1
- Rendement = 98%

$$P = 9 \times 1 \times 0.95 \times 1.02 = 10.5 \text{ Kw}$$

$$\text{Speed / Vitesse } n1 = 1000 \text{ min}^{-1}$$

- Solid shaft n1 on the left : **Y** (see p. 10)
- Keyed hollow bore shaft on n2 : **BH** (see p. 10)
- Direction of rotation n1 : clockwise (from the front of shaft n1)
- Direction of rotation n2 : anticlockwise (from the front of shaft n2)  
= rotation direction **O** (see p. 10)
- Horizontal mounting position for shafts n1 and n2, fixation from the upper side : **KS** (see p. 11)
- Oil splash lubrication : **2** (see p. 13)
- No external cooling required : **N**
- Two single lip Viton seals : **DE**

- Arbre n1 plein à gauche : **Y** (voir p. 10)
- Arbre n2 claveté traversant : **BH** (voir p. 10)
- Sens de rotation n1: horaire (face à l'arbre n1)
- Sens de rotation n2 : anti-horaire (face à l'arbre n2)  
= sens de rotation **O** (voir p. 10)

- Arbre n1 et n2 horizontaux, avec fixation sur le dessus : **KS** (voir p. 11)
- Lubrification par barbotage (bain d'huile) : **2** (voir p. 13)
- Système de refroidissement inutile : **N**
- Etanchéité par 2 bagues Viton simple lèvre : **DE**

Example of ordering code (See p 15)  
Exemple de codification (voir p 15)

**Z12 BHY 1 OKS 2 N DE**



## LUBRICATION - COOLING LUBRIFICATION - REFROIDISSEMENT

### LUBRICATION CODES CODES DE LUBRIFICATION

The rating tables shown on following pages provide basic guidelines for the lubrication requirements. It is always strongly recommended to contact your local supplier to ensure the correct choice.

#### Standard lubrication codes

Only for mounting position **K**, and horizontal shafts **n1**, **n2**

- 1 Standard grease (grade NLGI 0 or OO)
- 2 Oil splash lubrication (ISO viscosity 150 cst at 40°C)

#### Optional lubrication codes

- 0 Grease lubrication, special nuclear grade
- 3 Oil splash lubrication with internal pump (mono piston) (see table below)
- 4 Flow through lubrication with Pollard pump
- 5 Flow through with external tank
- 6 Flow through, external tank, dry sump

#### Labyrinth seals special lubrication codes

- 10 Flow through, external tank, dry sump (6) + labyrinth seals
- 12 Oil splash (2) + labyrinth seals
- 13 Oil splash lubrication with internal pump (3) + labyrinth seals

Le tableaux de puissances nominales fournis sur les pages suivantes indiquent les limites théoriques selon le choix des mode de lubrification.

Il est néanmoins fortement recommandé de consulter votre fournisseur local pour garantir le choix définitif.

#### Codes de lubrification standard

Uniquement pour position **K**, et arbres **n1**, **n2** horizontaux

- 1 Graisse standard (grade NLGI 0 ou OO)
- 2 Barbotage (ISO viscosité 150 cst à 40°C)

#### Codes de lubrification optionnelle

- 0 Graisse compatible applications nucléaires
- 3 Barbotage et pompe interne (mono piston) (voir tableau ci-dessous)
- 4 Circuit de lubrification par pompe Pollard
- 5 Circuit de lubrification avec réservoir extérieur
- 6 Circuit de lubrification, carter sec, réservoir ext.

#### Codes spécifiques aux versions "sans joints"

- 10 Circuit de lub., carter sec, réservoir ext. (6) + "sans joints"
- 12 Barbotage (2) + "sans joints"
- 13 Barbotage et pompe interne (3) + "sans joints"

### WORKING CONDITIONS LIMITS FOR USING THE INTERNAL PUMP LIMITES D'UTILISATION DE LA POMPE INTERNE

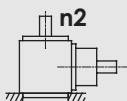
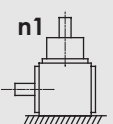
Working position <b>L</b> or <b>M</b> Position de travail <b>L</b> ou <b>M</b>		Size / Taille	16	20
		Speed / Vitesse (min <sup>-1</sup> )	[ 1750 ... 2200 ]	[ 1500 ... 1875 ]
		Size / Taille	25	31
		Speed / Vitesse (min <sup>-1</sup> )	[ 1250 ... 1875 ]	[ 1000 ... 1875 ]
Working position <b>N</b> or <b>P</b> Position de travail <b>N</b> ou <b>P</b>		Size / Taille	16	20
		Speed / Vitesse (min <sup>-1</sup> )	[ 1500 ... 1750 ]	[ 1250 ... 1500 ]
		Size / Taille	25	31
		Speed / Vitesse (min <sup>-1</sup> )	[ 1000 ... 1250 ]	[ 750 ... 1250 ]

### COOLING REFROIDISSEMENT

- N** No external cooling required
- R** External cooling required (please consult your supplier)

- N** Système de refroidissement inutile
- R** Système de refroidissement obligatoire (consulter le distributeur local)



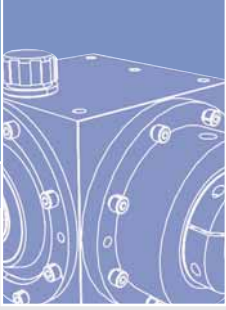

### SEALING ÉTANCHEITE

#### FOUR MAIN SEALING LEVELS QUATRE PRINCIPAUX NIVEAUX D'ÉTANCHEITE

--	Single lip Viton seal (no code to be mentioned for the basic version)	--	Bague d'étanchéité Viton (aucun code d'étanchéité pour la version de base)
<b>DL</b>	Viton seal with single dust lip	<b>DL</b>	Bague d'étanchéité Viton avec lèvres anti-poussière
<b>DE</b>	Two single lip Viton seals (*)	<b>DE</b>	Deux bagues d'étanchéité Viton (*)
<b>DEDL</b>	Same as <b>DE</b> , one with dust lip (*) (* except : Z08 / Z10 , Z110 / Z112 / Z116 / Z120	<b>DEDL</b>	Idem <b>DE</b> , l'une des bagues avec lèvres anti-poussière (*) (* sauf : Z08 / Z10 , Z110 / Z112 / Z116 / Z120

#### Note : Labyrinth seal special case

The labyrinth seal version is specified in the lubrication codes 10, 12 or 13 (see p 13).  
When choosing the labyrinth seal option, leave the sealing level in the product ordering code blank.

#### Nota : Cas de l'étanchéité spéciale "sans joints"

Le choix de l'étanchéité spéciale "sans joints" est donné par le choix du code de lubrification 10, 12 ou 13 (voir p 13).  
Lors du choix de cette version, aucun code d'étanchéité ne doit être indiqué dans le code de commande

#### LABYRINTH SEALS VERSIONS

The labyrinth seal versions have been specially designed for applications where very low maintenance is essential.

##### Main features

- Up to 50 000 hours of maintenance free life
- Frictionless : efficiency up to 99 %
- High rotation speed
- Static torque dramatically reduced
- Units frame temperature up to 30°C lower than with standard Z units
- Available on types Z and ZR (size 16, 20, 25, 31)

Note : by design, the use of labyrinth seal versions is not recommended for vertical bottom shaft positions.  
The use of labyrinth seal versions in applications involving high acceleration/deceleration is not recommended.

#### VERSIONS "SANS JOINTS"

Les versions "sans joints" ont été spécialement conçues pour les applications où une maintenance très réduite est un facteur crucial.

##### Principales caractéristiques

- Jusqu'à 50.000 heures de fonctionnement sans entretien
- Sans frottement : rendement atteignant 99 %
- Vitesses de rotation élevées
- Couple de démarrage fortement réduit
- Température de fonctionnement inférieure de plus de 30°C par rapport au standard Z
- Versions disponibles sur les gammes Z et ZR (tailles 16, 20, 25, 31)

Nota : Par conception, les versions à arbres verticaux vers le bas ne sont pas recommandées.  
L'intégration des versions "sans joints" est déconseillée pour des applications embarquées avec fortes accélérations/décélérations.

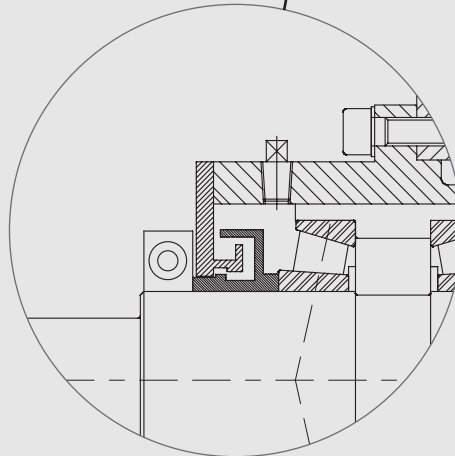
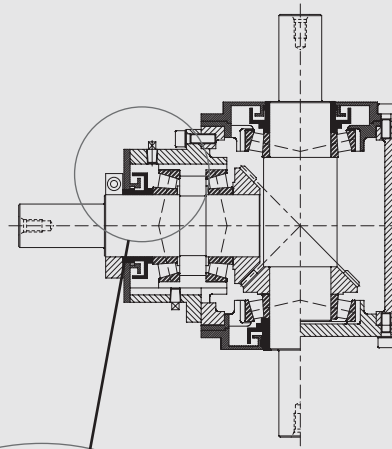

# Z Series - Right angle Spiral Bevel Gearboxes

## Série Z - Renvois d'angle



### ORDERING CODE CODIFICATION

Z Series Série Z

ex.	Z	12	EJ	1	O	L	S	2	N	DE
Range / Gamme										
Universal / Universel	Z									
Pinion on through shaft (multiplier) / Arbre rapide traversant	ZT									
Reinforced through shaft / Arbre n2 renforcé	ZR									
Manual Forward, Neutral & Reverse / Debrayage, Inverseur, Point mort	ZI									
Manual slide dog clutch / Débrayage, Point mort	ZD									
3 axis version of Z Serie / Version tridirectionnelle de la Serie Z	ZX									
Size / Taille										
80		8								
100		10								
125		12								
160		16								
200		20								
250		25								
315		31								
Input-Output / Interfaces entrée-sortie - page 10										
Solid shaft / Arbre plein					C-F-J-Y					
Keyed hollow bore / Arbre creux claveté					B-E-H-W					
Splined hollow bore / Arbre creux cannelé					K-L-N-P					
Keyed hollow bore + Flange / Arbre creux claveté + Flasque					A-D-G-V					
Splined hollow bore + Flange / Arbre creux cannelé + Flasque					M-R-S-T					
Ratio / Rapport (i = n1 / n2)										
0.5 ZT only / uniquement				0.5						
0.666 ZT only / uniquement				0.67						
0.8 Z - ZR				0.8						
1 Z - ZR - ZD - ZI				1						
1.25 Z - ZR - ZD - ZI - ZX				1.25						
1.5 Z - ZR - ZD - ZI - ZX				1.5						
2 Z - ZR - ZD - ZI - ZX				2						
3 Z - ZR - ZD - ZI - ZX				3						
4 Z - ZR - ZX				4						
5 Z - ZR - ZX				5						
6 Z - ZR - ZX				6						
Direction of rotation / Sens de rotation										
O					O					
I					I					
Mounting position / Position de fonctionnement										
See / Voir page 11						K-L-M-N-P				
Mounting surface / Face de fixation										
See / Voir page 11							R-S-T-U-X-Z			
Lubrication / Lubrification										
Grease / Graisse								1		
Oil splash / Barbotage								2		
(2) + Internal pump / Pompe interne								3		
(2) + External pump / Pompe externe								4		
Oil forced w/ external tank / Circuit avec réservoir extérieur								5		
Dry sump lub w/ external tank / Carter sec avec réservoir ext.								6		
(6) with labyrinth seals / avec étanchéité par chicanes								10		
(2) with labyrinth seals / avec étanchéité par chicanes								12		
(3) with labyrinth seals / avec étanchéité par chicanes								13		
Cooling option / Système de refroidissement										
With / Avec									R	
Without / Sans									N	
Sealing options / Système d'étanchéité										
Single lip Viton seal / Simple étanchéité										-
Single lip seal + Dust lip / Simple étanchéité + lèvres anti-poussière										DL
Two single lip seals / Double étanchéité										DE
Two single lip seals + Dust lip / Double étanchéité + lèvres anti-poussière										DEDL

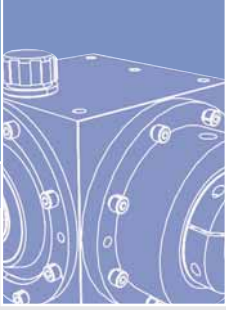

**AXIAL AND RADIAL LOAD**  
**CHARGES AXIALES et RADIALES**

Maximum radial load on center of shaft (N)  
*Charge radiale admissible en milieu d'arbre (N)*

**n1**

Speed / Vitesse min <sup>-1</sup>	Ø Shaft / Ø Arbre							
	15	20	25	30	35	45	60	75
500	370	760	1600	2000	3160	5800	9000	14000
1000	320	660	1400	1660	2800	5100	8000	12550
1500	260	600	1200	1600	2330	4660	7320	11500
2000	250	530	1150	1450	2150	4000	6450	10000
2500	210	460	1000	1200	1850	3660	5660	8770
3000	190	430	860	1100	1660	3150	5000	7900

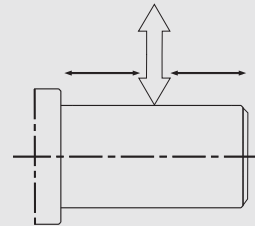

**n2**

Speed / Vitesse min <sup>-1</sup>	Ø Shaft / Ø Arbre							
	15	20	25	30	35	45	60	75
500	460	950	2000	2500	3950	7250	11250	16800
1000	400	820	1750	2070	3500	6370	10000	15000
1500	330	750	1500	2000	2910	5820	9150	13700
2000	310	660	1430	1810	2680	5000	8060	12000
2500	270	580	1250	1500	2310	4570	7070	10600
3000	230	530	1070	1370	2070	3930	6250	9375

Maximum axial load on end of shaft (N)  
*Charge axiale admissible en bout d'arbre (N)*

**n1**

Speed / Vitesse min <sup>-1</sup>	Ø Shaft / Ø Arbre							
	15	20	25	30	35	45	60	75
500	180	380	800	1000	1580	2900	4500	6750
1000	160	330	700	830	1400	2550	4000	6000
1500	130	300	600	800	1160	2330	3660	5500
2000	125	260	570	720	1070	2000	3220	4800
2500	105	230	500	600	920	1830	2830	4200
3000	95	210	430	550	830	1570	2500	3750

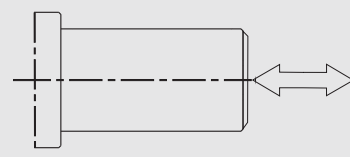

**n2**

Speed / Vitesse min <sup>-1</sup>	Ø Shaft / Ø Arbre							
	15	20	25	30	35	45	60	75
500	230	470	1000	1250	1970	3620	5620	8400
1000	200	410	870	1030	1750	2680	5000	7500
1500	160	370	750	1000	1450	2810	4570	6800
2000	150	330	710	900	1340	2500	4030	6050
2500	130	290	620	750	1150	2280	3530	5200
3000	110	260	530	680	1030	1960	3120	4700

All data subject to change without notice  
 Données susceptibles d'être modifiées sans préavis



## INERTIA - TORSIONAL STIFFNESS INERTIES - RAIDEURS TORSIONNELLES

Inertia on **n1** / Inerties sur **n1** ( $10^{-3}$  N.m.s<sup>2</sup>)

i = n1 / n2

Size / Taille	0.8	1	1.25	1.5	2	3	4	5	6	0.5	0.66
<b>Z - ZT 08</b>	0.152	0.142	0.098	0.117	0.079	0.050	0.042	0.038	0.036	0.219	0.211
<b>Z - ZT 10</b>	0.412	0.395	0.257	0.306	0.229	0.165	0.132	0.117	0.109	0.715	0.687
<b>Z - ZT 12</b>	1.060	0.994	0.731	0.958	0.694	0.382	0.379	0.333	0.310	2.220	1.740
<b>Z - ZT 16</b>	5.160	4.230	3.260	3.410	2.760	1.710	1.670	1.520	1.440	7.560	6.640
<b>Z - ZT 20</b>	13.20	11.40	8.160	9.780	7.380	4.020	3.750	3.290	3.040	24.57	21.58
<b>Z - ZT 25</b>	45.20	37.80	29.30	30.00	25.90	13.80	12.10	10.80	10.10	80.09	70.13
<b>Z - ZT 31</b>	133.0	105.0	86.00	92.00	69.00	38.00	32.00	28.00	28.00	227.0	205.0

Inertia on **n2** / Inerties sur **n2** ( $10^{-3}$  N.m.s<sup>2</sup>)

i = n1 / n2

Size / Taille	0.8	1	1.25	1.5	2	3	4	5	6	0.5	0.66
<b>Z - ZT 08</b>	0.097	0.142	0.154	0.264	0.317	0.448	0.671	0.953	1.290	0.055	0.094
<b>Z - ZT 10</b>	0.263	0.395	0.401	0.689	0.919	1.480	2.110	2.940	3.950	0.179	0.305
<b>Z - ZT 12</b>	0.679	0.994	1.140	2.150	2.780	3.440	6.070	8.330	11.20	0.555	0.774
<b>Z - ZT 16</b>	3.300	4.230	5.100	7.680	11.00	15.40	26.70	37.90	51.80	1.890	2.950
<b>Z - ZT 20</b>	8.430	11.40	12.70	22.00	29.50	36.10	60.10	82.30	109.0	6.140	9.580
<b>Z - ZT 25</b>	28.90	37.80	45.80	67.60	104.0	124.0	194.0	271.0	365.0	19.95	31.16
<b>Z - ZT 31</b>	85.00	105.0	135.0	208.0	277.0	342.0	516.0	699.0	1026	57.00	91.00

Stiffness on **n1** / Raideurs sur **n1** (Nm/Rd)

i = n1 / n2

Size / Taille	0.8	1	1.25	1.5	2	3	4	5	6	0.5	0.66
<b>Z - ZT 08</b>	14091	8487	6567	5231	3367	2297	1335	874	611	12737	9758
<b>Z - ZT 10</b>	26658	17104	13408	10707	6891	4311	2677	1745	1224	23270	19343
<b>Z - ZT 12</b>	43733	29853	22191	19109	11955	7179	4378	2840	1995	44979	34676
<b>Z - ZT 16</b>	85338	57683	43832	31993	23185	13288	8000	5260	3704	91344	71382
<b>Z - ZT 20</b>	185138	123561	117824	76734	49068	27126	16694	11094	7857	173553	135625
<b>Z - ZT 25</b>	452970	320314	287708	198371	133623	72213	40083	26831	18998	329751	257689
<b>Z - ZT 31</b>	782563	636416	489491	414684	245142	121182	71694	47471	32650	833779	643265

Stiffness on **n2** / Raideurs sur **n2** (Nm/Rd)

i = n1 / n2

Size / Taille	0.8	1	1.25	1.5	2	3	4	5	6	0.5	0.66
<b>Z - ZT 08</b>	9018	8487	10261	11770	13468	20681	21358	21851	22002	3184	4337
<b>Z - ZT 10</b>	17061	17104	20950	24091	27565	38801	42839	43623	44061	5817	8597
<b>Z - ZT 12</b>	27989	29853	34673	42995	47820	64615	70048	71019	71819	11245	15411
<b>Z - ZT 16</b>	54616	57683	68488	71985	92740	119598	128000	131499	133352	22836	31725
<b>Z - ZT 20</b>	118488	123561	184100	172652	196274	244138	267107	277360	282859	43388	60277
<b>Z - ZT 25</b>	289901	320314	449543	446334	534493	649921	641331	670787	683931	82437	114527
<b>Z - ZT 31</b>	500840	636416	764830	933039	980567	1090630	1147110	1186780	1175410	208445	285896

Note : tables valid for solid shafts n1 and n2

Nota : tables correspondant à la configuration arbres pleins n1 et n2

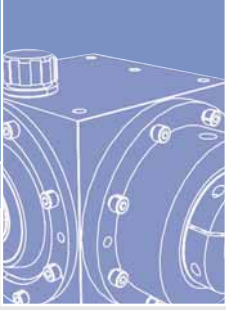

# Z Series - Right angle Spiral Bevel Gearboxes

## Série Z - Renvois d'angle

### POWER & TORQUE - Z

### PUISSANCES ET COUPLES NOMINAUX Z

SPEED / VITESSE		SIZE / TAILLE 8				SIZE / TAILLE 10				SIZE / TAILLE 12			
n1 min <sup>-1</sup>	n2 min <sup>-1</sup>	P1 kW	T1 Nm	T2 Nm	Tc2 Nm	P1 kW	T1 Nm	T2 Nm	Tc2 Nm	P1 kW	T1 Nm	T2 Nm	Tc2 Nm
10	12.5	0.04	40	32	24	0.06	60	48	37	0.13	120	96	76
50	62.5	0.18	35	28	24	0.27	52	41	37	0.58	110	88	76
250	312.5	0.73	28	22.4	22.4	1.23	47	37	37	2.75	105	84	76
750	937.5	1.49	19	15.2	15.2	3.30	42	33	33	7.85	100	80	76
1000	1250	1.78	17	13.6	13.6	4.19	40	32	32	9.95	95	76	76
1500	1875	2.36	15	12	12	5.50	35	28	28	13.3	85	68	68
2000	2500	3.14	15	12	12	6.28	30	24	24	16	76	61	61
3000	3750	4.08	13	10.4	4	8.48	27	21	21	22	70	56	56

**i = 0.8**

SPEED / VITESSE		SIZE / TAILLE 16				SIZE / TAILLE 20				SIZE / TAILLE 25				SIZE / TAILLE 31			
n1 min <sup>-1</sup>	n2 min <sup>-1</sup>	P1 kW	T1 Nm	T2 Nm	Tc2 Nm	P1 kW	T1 Nm	T2 Nm	Tc2 Nm	P1 kW	T1 Nm	T2 Nm	Tc2 Nm	P1 kW	T1 Nm	T2 Nm	Tc2 Nm
10	12.5	0.37	350	280	169	0.68	650	520	350	1.31	1250	1000	600	3.03	2900	2320	1200
50	62.5	1.54	295	236	169	3.14	600	480	350	6.02	1150	920	600	14.1	2700	2160	1200
250	312.5	7.46	285	228	169	14.6	560	448	350	28.8	1100	880	600	57.6	2200	1760	1200
750	937.5	18	230	184	169	34.5	440	352	350	63.6	810	648	600	141	1800	1440	1200
1000	1250	22	210	168	168	42	400	320	320	78.5	750	600	600	167	1600	1280	1200
1500	1875	29.8	190	152	152	56.5	360	288	288	105	670	536	536	220	1400	1120	1120
2000	2500	35.6	170	136	136	69	330	264	264	129	620	496	496	<b>272</b>	<b>1300</b>	<b>1040</b>	<b>1040</b>
3000	3750	47	150	120	120	<b>91</b>	<b>290</b>	<b>232</b>	<b>232</b>	<b>169</b>	<b>540</b>	<b>432</b>	<b>432</b>				
3500	4375	<b>52.5</b>	<b>143</b>	<b>114</b>	<b>114</b>	<b>98.7</b>	<b>269</b>	<b>215</b>	<b>215</b>								
4500	5625	<b>58</b>	<b>123</b>	<b>98</b>	<b>98</b>												

Labyrinth seals only  
Versions sans joints

SPEED / VITESSE		SIZE / TAILLE 8				SIZE / TAILLE 10				SIZE / TAILLE 12			
n1 min <sup>-1</sup>	n2 min <sup>-1</sup>	P1 kW	T1 Nm	T2 Nm	Tc2 Nm	P1 kW	T1 Nm	T2 Nm	Tc2 Nm	P1 kW	T1 Nm	T2 Nm	Tc2 Nm
10	10	0.05	44	44	28	0.09	90	90	66	0.21	200	200	130
50	50	0.18	34	34	28	0.72	80	80	66	0.84	160	160	130
250	250	0.76	29	29	28	1.96	75	75	66	3.93	150	150	130
750	750	1.88	24	24	24	5.5	70	70	66	9.2	117	117	117
1000	1000	2.3	22	22	22	6.81	65	65	65	11.2	107	107	107
1500	1500	3.14	20	20	20	8.95	57	57	57	15	95	95	95
2000	2000	3.56	17	17	17	10.7	51	51	51	17.8	85	85	85
3000	3000	4.71	15	15	15	14.1	45	45	45	23.9	76	76	76

**i = 1**

SPEED / VITESSE		SIZE / TAILLE 16				SIZE / TAILLE 20				SIZE / TAILLE 25				SIZE / TAILLE 31			
n1 min <sup>-1</sup>	n2 min <sup>-1</sup>	P1 kW	T1 Nm	T2 Nm	Tc2 Nm	P1 kW	T1 Nm	T2 Nm	Tc2 Nm	P1 kW	T1 Nm	T2 Nm	Tc2 Nm	P1 kW	T1 Nm	T2 Nm	Tc2 Nm
10	10	0.4	380	380	270	0.84	800	800	550	1.88	1800	1800	950	3.45	3300	3300	1500
50	50	1.57	300	300	270	3.4	650	650	550	8.38	1600	1600	950	15.7	3000	3000	1500
250	250	7.46	285	285	270	16	610	610	550	31	1200	1200	950	62.8	2400	2400	1500
750	750	20	255	255	255	38.5	490	490	490	75	960	960	950	151	1920	1920	1500
1000	1000	24.8	237	237	237	47	450	450	450	93	890	890	890	186	1780	1780	1500
1500	1500	32.6	208	208	208	63	400	400	400	125	800	800	800	251	1600	1600	1500
2000	2000	40	190	190	190	76	365	365	365	151	720	720	720	<b>301</b>	<b>1440</b>	<b>1440</b>	<b>1440</b>
3000	3000	53.4	170	170	170	<b>102</b>	<b>325</b>	<b>325</b>	<b>325</b>	<b>201</b>	<b>640</b>	<b>640</b>	<b>640</b>				
3500	3500	<b>58</b>	<b>158</b>	<b>158</b>	<b>158</b>	<b>110</b>	<b>300</b>	<b>300</b>	<b>300</b>	<b>218</b>	<b>595</b>	<b>595</b>	<b>595</b>				
4500	4500	<b>64.4</b>	<b>137</b>	<b>137</b>	<b>137</b>	<b>123</b>	<b>261</b>	<b>261</b>	<b>261</b>								
5500	5500	<b>68</b>	<b>118</b>	<b>118</b>	<b>118</b>												

Labyrinth seals only  
Versions sans joints

i : Ratio n1/n2      Rapport n1/n2  
n1 : Speed n1      Vitesse sur n1  
n2 : Speed n2      Vitesse sur n2  
P1 : Power n1      Puissance sur n1  
T1 : Torque on n1      Couple sur n1  
T2 : Torque on n2      Couple sur n2  
Tc2 : Torque on n2 (hollow bore)      Couple sur n2 (arbre creux)

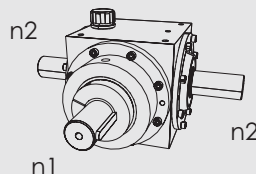

- Standard grease      Graisse standard
- Oil splash lubrication      Lubrification par barbotage
- Forced lubrication      Lubrification forcée
- Forced lubrication - labyrinth seals      Lubrification forcée - sans joints

**1440**

All data subject to change without notice  
Données susceptibles d'être modifiées sans préavis



POWER & TORQUE - Z  
 PUISSANCES ET COUPLES NOMINAUX Z

**i = 1.25**

SPEED / VITESSE		SIZE / TAILLE 8				SIZE / TAILLE 10				SIZE / TAILLE 12			
n1 min <sup>-1</sup>	n2 min <sup>-1</sup>	P1 kW	T1 Nm	T2 Nm	Tc2 Nm	P1 kW	T1 Nm	T2 Nm	Tc2 Nm	P1 kW	T1 Nm	T2 Nm	Tc2 Nm
10	8	0.02	19	23.7	23.7	0.05	50	62.5	62.5	0.11	105	131	119
50	40	0.1	19	23.7	23.7	0.22	42	52.5	52.5	0.49	94	117	117
250	200	0.45	17	21.2	21.2	1.05	40	50	50	2.23	85	106	106
750	600	1.18	15	18.7	18.7	2.98	38	47.5	47.5	6.68	85	106	106
1000	800	1.47	14	17.5	17.5	3.98	38	47.5	47.5	8.38	80	100	100
1500	1200	2.04	13	16.2	16.2	5.50	35	43.7	43.7	11.3	72	90	90
2000	1600	2.51	12	15	15	6.28	30	37.5	37.5	12.6	60	75	75
3000	2400	3.46	11	13.7	13.7	7.85	25	31	31	15.7	50	62	62

SPEED / VITESSE		SIZE / TAILLE 16				SIZE / TAILLE 20				SIZE / TAILLE 25				SIZE / TAILLE 31			
n1 min <sup>-1</sup>	n2 min <sup>-1</sup>	P1 kW	T1 Nm	T2 Nm	Tc2 Nm	P1 kW	T1 Nm	T2 Nm	Tc2 Nm	P1 kW	T1 Nm	T2 Nm	Tc2 Nm	P1 kW	T1 Nm	T2 Nm	Tc2 Nm
10	8	0.25	240	300	250	0.52	500	625	500	1.05	1000	1250	1000	2.4	2300	2875	1600
50	40	1.2	230	287	250	2.51	480	600	500	4.97	950	1187	1000	11.5	2200	2750	1600
250	200	5.5	210	262	250	9.95	380	475	475	22.2	850	1060	1000	47.1	1800	2250	1600
750	600	14.9	190	237	237	25.9	330	412	412	57.3	730	912	912	117	1500	1875	1600
1000	800	18.9	180	225	225	33	315	394	394	71.2	680	850	850	157	1500	1875	1600
1500	1200	25.1	160	200	200	46	293	366	366	94	600	750	750	204	1300	1625	1600
2000	1600	31.4	150	187	187	52.3	250	312	312	111	530	662	662	251	1200	1500	1500
3000	2400	40.8	130	162	162	66	210	262	262	<b>154</b>	<b>490</b>	<b>612</b>	<b>612</b>				
3500	2800	<b>44.2</b>	<b>121</b>	<b>151</b>	<b>151</b>	<b>71.6</b>	<b>195</b>	<b>244</b>	<b>244</b>	<b>167</b>	<b>455</b>	<b>570</b>	<b>570</b>				
4500	3600	<b>49.2</b>	<b>104</b>	<b>130</b>	<b>130</b>	<b>80</b>	<b>170</b>	<b>212</b>	<b>212</b>								
5500	4400	<b>52</b>	<b>90</b>	<b>113</b>	<b>113</b>												

Labyrinth seals only  
 Versions sans joints

**i = 1.5**

SPEED / VITESSE		SIZE / TAILLE 8				SIZE / TAILLE 10				SIZE / TAILLE 12			
n1 min <sup>-1</sup>	n2 min <sup>-1</sup>	P1 kW	T1 Nm	T2 Nm	Tc2 Nm	P1 kW	T1 Nm	T2 Nm	Tc2 Nm	P1 kW	T1 Nm	T2 Nm	Tc2 Nm
10	6.6	0.04	35	52.5	52.5	0.08	75	112	112	0.16	155	232	232
50	33.3	0.15	28	42	42	0.37	70	105	105	0.73	140	210	210
250	166.6	0.52	20	30	30	1.70	65	97	97	3.40	130	195	195
750	500	1.41	18	27	27	4.71	60	90	90	8.25	105	157	157
1000	666.6	1.78	17	25.5	25.5	5.76	55	82	82	10.1	97	145	140
1500	1000	2.36	15	22.5	22.5	7.70	49	73	73	13.5	86	129	129
2000	1333.3	2.72	13	19.5	19.5	9.21	44	66	66	16.5	79	118	118
3000	2000	3.77	12	18	18	12.2	39	58	58	22	70	105	105

SPEED / VITESSE		SIZE / TAILLE 16				SIZE / TAILLE 20				SIZE / TAILLE 25				SIZE / TAILLE 31			
n1 min <sup>-1</sup>	n2 min <sup>-1</sup>	P1 kW	T1 Nm	T2 Nm	Tc2 Nm	P1 kW	T1 Nm	T2 Nm	Tc2 Nm	P1 kW	T1 Nm	T2 Nm	Tc2 Nm	P1 kW	T1 Nm	T2 Nm	Tc2 Nm
10	6.6	0.39	375	562	562	0.63	600	900	810	1.36	1300	1950	1500	2.82	2700	4050	2500
50	33.3	1.57	300	450	450	2.88	550	825	810	6.28	1200	1800	1500	12.5	2400	3600	2500
250	166.6	6.81	260	390	390	13.5	515	772	772	26.2	1000	1500	1500	52.3	2000	3000	2500
750	500	16.7	213	319	319	34.5	440	660	660	65	830	1245	1245	133	1700	2550	2500
1000	666.6	20.4	195	292	292	42	400	600	600	79.6	760	1140	1140	167	1600	2400	2400
1500	1000	27.5	175	262	262	56.5	360	540	540	107	680	1020	1020	213	1360	2040	2040
2000	1333.3	33.5	160	240	240	68	325	487	487	130	620	930	930	261	1250	1875	1875
3000	2000	44	140	210	210	92	295	442	442	<b>173</b>	<b>550</b>	<b>825</b>	<b>825</b>				
3500	2333	48	131	196	196	<b>100</b>	<b>273</b>	<b>409</b>	<b>409</b>	<b>188</b>	<b>513</b>	<b>769</b>	<b>769</b>				
4500	3000	<b>53</b>	<b>112</b>	<b>169</b>	<b>169</b>	<b>111</b>	<b>235</b>	<b>353</b>	<b>353</b>								
5500	3666	<b>56.2</b>	<b>97</b>	<b>146</b>	<b>146</b>												

Labyrinth seals only  
 Versions sans joints

- i: Ratio n1/n2      Rapport n1/n2
- n1: Speed n1      Vitesse sur n1
- n2: Speed n2      Vitesse sur n2
- P1: Power n1      Puissance sur n1
- T1: Torque on n1      Couple sur n1
- T2: Torque on n2      Couple sur n2
- Tc2: Torque on n2 (hollow bore)      Couple sur n2 (arbre creux)

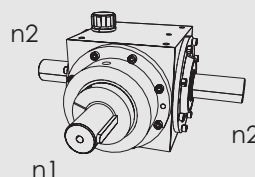

- Standard grease      Graisse standard
- Oil splash lubrication      Lubrification par barbotage
- Forced lubrication      Lubrification forcée
- Forced lubrication - labyrinth seals      Lubrification forcée - sans joints

1440

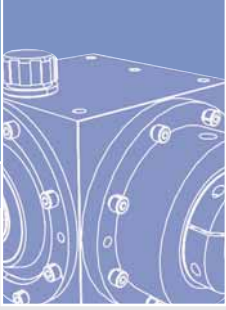

# Z Series - Right angle Spiral Bevel Gearboxes

## Série Z - Renvois d'angle

### POWER & TORQUE - Z

### PUISSANCES ET COUPLES NOMINAUX Z

SPEED / VITESSE		SIZE / TAILLE 8				SIZE / TAILLE 10				SIZE / TAILLE 12				<b>i = 2</b>
n1 min <sup>-1</sup>	n2 min <sup>-1</sup>	P1 kW	T1 Nm	T2 Nm	Tc2 Nm	P1 kW	T1 Nm	T2 Nm	Tc2 Nm	P1 kW	T1 Nm	T2 Nm	Tc2 Nm	
10	5	0.03	24	48	48	0.06	55	110	110	0.1	100	200	200	
50	25	0.1	19	38	38	0.24	45	90	90	0.5	95	190	190	
250	125	0.45	17	34	34	1.1	42	84	84	2.17	83	166	166	
750	375	1.18	15	30	30	3.3	42	84	84	6.13	78	156	156	
1000	500	1.47	14	28	28	4.4	42	84	84	7.85	73	146	146	
1500	750	1.88	12	24	24	6.28	40	80	80	11	65	130	130	
2000	1000	2.3	11	22	22	7.96	38	76	76	13.6	60	120	120	
3000	1500	3.14	10	20	20	11.3	36	72	72	18.2	52	104	104	

SPEED / VITESSE		SIZE / TAILLE 16				SIZE / TAILLE 20				SIZE / TAILLE 25				SIZE / TAILLE 31				Labyrinth seals only Versions sans joints
n1 min <sup>-1</sup>	n2 min <sup>-1</sup>	P1 kW	T1 Nm	T2 Nm	Tc2 Nm	P1 kW	T1 Nm	T2 Nm	Tc2 Nm	P1 kW	T1 Nm	T2 Nm	Tc2 Nm	P1 kW	T1 Nm	T2 Nm	Tc2 Nm	
10	5	0.21	200	400	400	0.5	480	960	700	1.05	1000	2000	1500	1.88	1800	3600	2500	
50	25	0.99	190	380	380	2.15	410	820	700	4.35	830	1660	1500	8.37	1600	3200	2500	
250	125	4.71	180	360	360	10.2	390	780	700	18.3	700	1400	1400	36.6	1400	2800	2500	
750	375	13	165	330	330	25	320	640	640	47	600	1200	1200	98	1250	2500	2500	
1000	500	15.7	150	300	300	31	295	590	590	58	560	1120	1120	125	1200	2400	2400	
1500	750	21	135	270	270	40.8	260	520	520	78	500	1000	1000	157	1000	2000	2000	
2000	1000	26.2	125	250	250	50	240	480	480	92	440	880	880	188	900	1800	1800	
3000	1500	36	115	230	230	66	210	420	420	119	380	760	760					
3500	1750	39	106	212	212	71.6	195	390	390	129	327	654	654					
4500	2250	43.4	92	184	184	<b>80</b>	<b>170</b>	<b>340</b>	<b>340</b>									
5500	2750	<b>46</b>	<b>80</b>	<b>160</b>	<b>160</b>													

SPEED / VITESSE		SIZE / TAILLE 8				SIZE / TAILLE 10				SIZE / TAILLE 12				<b>i = 3</b>
n1 min <sup>-1</sup>	n2 min <sup>-1</sup>	P1 kW	T1 Nm	T2 Nm	Tc2 Nm	P1 kW	T1 Nm	T2 Nm	Tc2 Nm	P1 kW	T1 Nm	T2 Nm	Tc2 Nm	
10	3.33	0.01	12	36	36	0.03	25	75	75	0.06	57	171	171	
50	16.6	0.06	11	33	33	0.13	24	72	72	0.30	57	171	171	
250	83.3	0.26	10	30	30	0.58	22	66	66	1.31	50	150	150	
750	250	0.71	9	27	27	1.34	17	51	51	3.2	41	123	123	
1000	333.3	0.94	9	27	27	1.68	16	48	48	4.19	40	120	120	
1500	500	1.26	8	24	24	2.51	16	48	48	5.18	33	99	99	
2000	666.6	1.47	7	21	21	2.93	14	42	42	6.49	31	93	93	
3000	1000	1.88	6	18	18	4.08	13	39	39	9.42	30	90	90	

SPEED / VITESSE		SIZE / TAILLE 16				SIZE / TAILLE 20				SIZE / TAILLE 25				SIZE / TAILLE 31				Labyrinth seals only Versions sans joints
n1 min <sup>-1</sup>	n2 min <sup>-1</sup>	P1 kW	T1 Nm	T2 Nm	Tc2 Nm	P1 kW	T1 Nm	T2 Nm	Tc2 Nm	P1 kW	T1 Nm	T2 Nm	Tc2 Nm	P1 kW	T1 Nm	T2 Nm	Tc2 Nm	
10	3.33	0.1	95	285	285	0.24	230	690	690	0.47	450	1350	1350	0.89	850	2550	2500	
50	16.6	0.5	95	285	285	1.13	215	645	645	2.09	400	1200	1200	3.92	750	2250	2250	
250	83.3	2.2	84	252	252	5.1	195	585	585	9.01	344	1032	1032	18.3	700	2100	2100	
750	250	5.65	72	216	216	12.9	165	495	495	21.2	270	810	810	43.2	550	1650	1650	
1000	333.3	7.33	70	210	210	16.8	160	480	480	27.2	260	780	780	55.5	530	1590	1590	
1500	500	10.2	65	195	195	23.6	150	450	450	37.7	240	720	720	75.4	480	1440	1440	
2000	666.6	12.1	58	174	174	28.3	135	405	405	47.8	228	684	684	94.2	450	1350	1350	
3000	1000	15.7	50	150	150	39.3	125	375	375	67.3	214	642	642					
3500	1166	17	46	139	139	42.6	116	348	348	73	199	597	597					
4500	1500	19	40	121	121	47.5	101	302	302									
5500	1833	20	35	104	104													

i : Ratio n1/n2      Rapport n1/n2  
n1 : Speed n1      Vitesse sur n1  
n2 : Speed n2      Vitesse sur n2  
P1 : Power n1      Puissance sur n1  
T1 : Torque on n1      Couple sur n1  
T2 : Torque on n2      Couple sur n2  
Tc2 : Torque on n2 (hollow bore)      Couple sur n2 (arbre creux)

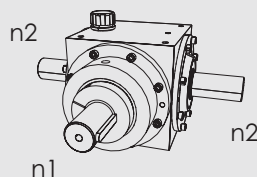

- Standard grease / Graisse standard
- Oil splash lubrication / Lubrification par barbotage
- Forced lubrication / Lubrification forcée
- Forced lubrication - labyrinth seals / Lubrification forcée - sans joints  **1440**

All data subject to change without notice  
Données susceptibles d'être modifiées sans préavis



POWER & TORQUE - Z  
 PUISSANCES ET COUPLES NOMINAUX Z

**i = 4**

SPEED / VITESSE		SIZE / TAILLE 8				SIZE / TAILLE 10				SIZE / TAILLE 12			
n1 min <sup>-1</sup>	n2 min <sup>-1</sup>	P1 kW	T1 Nm	T2 Nm	Tc2 Nm	P1 kW	T1 Nm	T2 Nm	Tc2 Nm	P1 kW	T1 Nm	T2 Nm	Tc2 Nm
10	2.5	0.01	5.5	22	22	0.02	15	60	60	0.04	35	140	140
50	12.5	0.03	5.3	21.2	21.2	0.07	13.5	54	54	0.16	31	124	124
250	62.5	0.13	4.9	19.6	19.6	0.33	12.5	50	50	0.71	27	108	108
750	187.5	0.31	3.9	15.6	15.6	0.86	11	44	44	1.81	23	92	92
1000	250	0.40	3.8	15.2	15.2	1.15	11	44	44	2.20	21	84	84
1500	375	0.60	3.8	15.2	15.2	1.57	10	40	40	3.14	20	80	80
2000	500	0.97	3.4	13.6	13.6	1.88	9	36	36	3.98	19	76	76
3000	750	1.04	3.3	13.2	13.2	2.51	8	32	32	5.65	18	72	72

SPEED / VITESSE		SIZE / TAILLE 16				SIZE / TAILLE 20				SIZE / TAILLE 25				SIZE / TAILLE 31			
n1 min <sup>-1</sup>	n2 min <sup>-1</sup>	P1 kW	T1 Nm	T2 Nm	Tc2 Nm	P1 kW	T1 Nm	T2 Nm	Tc2 Nm	P1 kW	T1 Nm	T2 Nm	Tc2 Nm	P1 kW	T1 Nm	T2 Nm	Tc2 Nm
10	2.5	0.06	60	240	240	0.15	143	572	572	0.25	240	960	960	0.50	480	1920	1920
50	12.5	0.3	57	228	228	0.7	133	532	532	1.2	230	920	920	2.4	460	1840	1840
250	62.5	1.31	50	200	200	3.01	115	460	460	6.02	230	920	920	10.5	400	1600	1600
750	187.5	3.53	45	180	180	7.54	96	384	384	13	166	664	664	28.3	360	1440	1440
1000	250	4.61	44	176	176	9.84	94	376	376	16.7	160	640	640	35.6	340	1360	1360
1500	375	6.28	40	160	160	14.1	90	360	360	22.8	145	580	580	47.1	300	1200	1200
2000	500	7.12	34	136	136	16.7	80	320	320	28.9	138	552	552	57.6	275	1100	1100
3000	750	10	32	128	128	23.5	75	300	300	40.8	130	520	520				
3500	875	10.9	30	119	119	25	68	273	273	43.3	121	483	483				
4500	1125	12	25.4	102	102	28.4	60	241	241								
5500	1375	12.8	22	89	89												

Labyrinth seals only  
 Versions sans joints

**i = 5**

SPEED / VITESSE		SIZE / TAILLE 8				SIZE / TAILLE 10				SIZE / TAILLE 12			
n1 min <sup>-1</sup>	n2 min <sup>-1</sup>	P1 kW	T1 Nm	T2 Nm	Tc2 Nm	P1 kW	T1 Nm	T2 Nm	Tc2 Nm	P1 kW	T1 Nm	T2 Nm	Tc2 Nm
10	2	0.0035	3.3	16.5	16.5	0.01	9.5	47.5	47.5	0.022	21	105	105
50	10	0.0168	3.2	16	16	0.05	9	45	45	0.104	20	100	100
250	50	0.078	3	15	15	0.21	8	40	40	0.497	19	95	95
750	150	0.188	2.4	12	12	0.51	6.5	32.5	32.5	1.178	15	75	75
1000	200	0.230	2.2	11	11	0.68	6.5	32.5	32.5	1.57	15	75	75
1500	300	0.330	2.1	10.5	10.5	0.94	6	30	30	2.2	14	70	70
2000	400	0.439	2.1	10.5	10.5	1.25	6	30	30	2.72	13	65	65
3000	600	0.628	2	10	10	1.88	6	30	30	3.77	12	60	60

SPEED / VITESSE		SIZE / TAILLE 16				SIZE / TAILLE 20				SIZE / TAILLE 25				SIZE / TAILLE 31			
n1 min <sup>-1</sup>	n2 min <sup>-1</sup>	P1 kW	T1 Nm	T2 Nm	Tc2 Nm	P1 kW	T1 Nm	T2 Nm	Tc2 Nm	P1 kW	T1 Nm	T2 Nm	Tc2 Nm	P1 kW	T1 Nm	T2 Nm	Tc2 Nm
10	2	0.04	38	190	190	0.09	85	425	425	0.16	158	790	790	0.31	300	1500	1500
50	10	0.183	35	175	175	0.42	80	400	400	0.8	153	765	765	1.41	270	1350	1350
250	50	0.86	33	165	165	1.91	73	365	365	3.53	135	675	675	6.54	250	1250	1250
750	150	2.04	26	130	130	5.18	66	330	330	8.64	110	550	550	17.3	220	1100	1100
1000	200	2.51	24	120	120	6.7	64	320	320	11	105	525	525	20.9	200	1000	1000
1500	300	3.61	23	115	115	9.42	60	300	300	15.7	100	500	500	28.3	180	900	900
2000	400	4.6	22	110	110	11.5	55	275	275	19.3	92	460	460	33.5	160	800	800
3000	600	6.59	21	105	105	17.3	55	275	275	26.7	85	425	425				
3500	700	7.2	20	98	98	18.8	51	256	256	29	79	395	395				
4500	900	8	17	85	85	21	44.5	223	223								
5500	1100	8.4	15	75	75												

Labyrinth seals only  
 Versions sans joints

i : Ratio n1/n2      Rapport n1/n2  
 n1 : Speed n1      Vitesse sur n1  
 n2 : Speed n2      Vitesse sur n2  
 P1 : Power n1      Puissance sur n1  
 T1 : Torque on n1      Couple sur n1  
 T2 : Torque on n2      Couple sur n2  
 Tc2 : Torque on n2 (hollow bore)      Couple sur n2 (arbre creux)

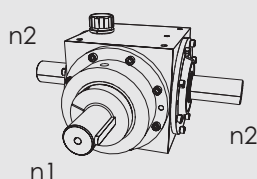

- Standard grease  Graisse standard
- Oil splash lubrication  Lubrification par barbotage
- Forced lubrication  Lubrification forcée



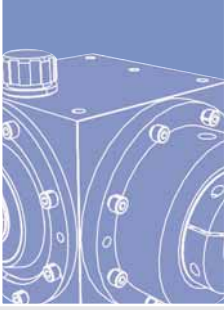

POWER & TORQUE - Z  
 PUISSANCES ET COUPLES NOMINAUX Z

**i = 6**

SPEED / VITESSE		SIZE / TAILLE 8				SIZE / TAILLE 10				SIZE / TAILLE 12			
n1 min <sup>-1</sup>	n2 min <sup>-1</sup>	P1 kW	T1 Nm	T2 Nm	Tc2 Nm	P1 kW	T1 Nm	T2 Nm	Tc2 Nm	P1 kW	T1 Nm	T2 Nm	Tc2 Nm
10	1.66	0.0026	2.5	15	15	0.006	5.9	35.4	35.4	0.02	19	114	114
50	8.33	0.0126	2.4	14.4	14.4	0.029	5.7	34.2	34.2	0.10	19	114	114
250	41.6	0.057	2.2	13.2	13.2	0.138	5.3	31.8	31.8	0.31	12	72	72
750	125	0.141	1.8	10.8	10.8	0.33	4.2	25.2	25.2	0.76	9.7	58	58
1000	166.6	0.178	1.7	10.2	10.2	0.42	4	24	24	1	9.6	57	57
1500	250	0.251	1.6	9.6	9.6	0.59	3.8	22.8	22.8	1.5	9.6	57	57
2000	333.3	0.335	1.6	9.6	9.6	0.77	3.7	22.2	22.2	1.67	8	48	48
3000	500	0.471	1.5	9	9	1.13	3.6	21.6	21.6	2.2	7	42	42

SPEED / VITESSE		SIZE / TAILLE 16				SIZE / TAILLE 20				SIZE / TAILLE 25				SIZE / TAILLE 31			
n1 min <sup>-1</sup>	n2 min <sup>-1</sup>	P1 kW	T1 Nm	T2 Nm	Tc2 Nm	P1 kW	T1 Nm	T2 Nm	Tc2 Nm	P1 kW	T1 Nm	T2 Nm	Tc2 Nm	P1 kW	T1 Nm	T2 Nm	Tc2 Nm
10	1.66	0.03	30	180	180	0.06	57	342	342	0.12	115	690	690	0.21	200	1200	1200
50	8.33	0.157	30	180	180	0.3	57	342	342	0.6	115	690	690	1	190	1140	1140
250	41.6	0.6	23	138	138	1.23	47	282	282	2.62	100	600	600	4.45	170	1020	1020
750	125	1.49	19	114	114	3.06	39	234	234	6.12	78	468	468	11.8	150	900	900
1000	166.6	1.67	16	96	96	4.08	39	234	234	7.54	72	432	432	15.7	150	900	900
1500	250	2.35	15	90	90	5.96	38	228	228	10.8	69	414	414	21.7	138	828	828
2000	333.3	3.03	14.5	87	87	7.33	35	210	210	14	67	402	402	26.1	125	750	750
3000	500	4.24	13.5	81	81	11	35	210	210	20	64	384	384				
3500	583	4.6	12.5	75	75	12	32	196	196	21.7	59	355	355				
4500	750	5.1	10.8	65	65	13.3	28	169	169								
5500	916	5.4	9.4	56	56												

Labyrinth seals only  
 Versions sans joints

i : Ratio n1/n2      Rapport n1/n2  
 n1 : Speed n1      Vitesse sur n1  
 n2 : Speed n2      Vitesse sur n2  
 P1 : Power n1      Puissance sur n1  
 T1 : Torque on n1      Couple sur n1  
 T2 : Torque on n2      Couple sur n2  
 Tc2 : Torque on n2      Couple sur n2  
 (hollow bore)      (arbre creux)

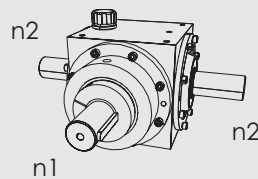

- Standard grease
- Graisse standard
- Oil splash lubrication
- Lubrification par barbotage
- Forced lubrication
- Lubrification forcée

All data subject to change without notice  
 Données susceptibles d'être modifiées sans préavis



POWER & TORQUE - ZT  
 PUISSANCES ET COUPLES NOMINAUX ZT

**i = 0.5**

SPEED / VITESSE		SIZE / TAILLE 8			SIZE / TAILLE 10			SIZE / TAILLE 12		
n1 min-1	n2 min-1	P1 Kw	T1 Nm	T2 Nm	P1 Kw	T1 Nm	T2 Nm	P1 Kw	T1 Nm	T2 Nm
5	10	0,03	48	24	0,06	110	55	0,1	200	100
25	50	0,1	38	19	0,24	90	45	0,5	190	95
125	250	0,45	34	17	1,1	84	42	2,17	166	83
250	500	0,89	34	17	2,2	84	42	4,19	160	80
375	750	1,18	30	15	3,3	84	42	6,13	156	78
500	1000	1,47	28	14	4,4	84	42	7,85	146	73
750	1500	1,88	24	12	6,28	80	40	11	130	65
1000	2000	2,3	22	11	7,96	76	38	13,6	120	60
1500	3000	3,14	20	10	11,3	72	36	18,2	104	52

SPEED / VITESSE		SIZE / TAILLE 16			SIZE / TAILLE 20			SIZE / TAILLE 25			SIZE / TAILLE 31		
n1 min-1	n2 min-1	P1 Kw	T1 Nm	T2 Nm	P1 Kw	T1 Nm	T2 Nm	P1 Kw	T1 Nm	T2 Nm	P1 Kw	T1 Nm	T2 Nm
5	10	0,21	400	200	0,5	960	480	1,05	2000	1000	1,88	3600	1800
25	50	0,99	380	190	2,15	820	410	4,35	1660	830	8,37	3200	1600
125	250	4,71	360	180	10,2	780	390	18,3	1400	700	36,6	2800	1400
250	500	8,9	340	170	18,3	700	350	34	1300	650	68	2600	1300
375	750	13	330	165	25	640	320	47	1200	600	98	2500	1250
500	1000	15,7	300	160	31	590	295	58	1120	560	125	2400	1200
750	1500	21	270	135	40,8	520	260	78	1000	500	157	2000	1000
1000	2000	26,2	250	125	50	480	240	92	880	440	188	1800	900
1500	3000	36	230	115	66	420	210	119	760	380	257	1640	820

**i = 0.666**

SPEED / VITESSE		SIZE / TAILLE 8			SIZE / TAILLE 10			SIZE / TAILLE 12		
n1 min-1	n2 min-1	P1 Kw	T1 Nm	T2 Nm	P1 Kw	T1 Nm	T2 Nm	P1 Kw	T1 Nm	T2 Nm
6.66	10	0.04	52.5	35	0.08	112	75	0.16	232	155
33.3	50	0.15	42	28	0.37	105	70	0.73	210	140
166.6	250	0.52	30	20	1.7	97	65	3.40	195	130
333.3	500	1	28.5	19	3.40	97	65	5.76	165	110
500	750	1.41	27	18	4.71	90	60	8.25	137	105
666.6	1000	1.78	25.5	17	5.76	82	55	10.1	145	97
1000	1500	2.36	22.5	15	7.7	73	49	13.5	129	86
1333.2	2000	2.72	19.5	13	9.21	66	44	16.5	118	79
2000	3000	3.77	18	12	12.2	58	39	22	105	70

SPEED / VITESSE		SIZE / TAILLE 16			SIZE / TAILLE 20			SIZE / TAILLE 25			SIZE / TAILLE 31		
n1 min-1	n2 min-1	P1 Kw	T1 Nm	T2 Nm	P1 Kw	T1 Nm	T2 Nm	P1 Kw	T1 Nm	T2 Nm	P1 Kw	T1 Nm	T2 Nm
6.66	10	0.39	561	375	0.63	900	600	1.36	1950	1300	2.82	4050	2700
33.3	50	1.57	450	300	2.88	825	550	6.28	1800	1200	12.5	3600	2400
166.6	250	6.81	390	260	13.5	772	515	26.2	1500	1000	52.3	3000	2000
333.3	500	12.3	352	235	25.7	735	490	47	1350	900	94.2	2700	1800
500	750	16.7	319	213	34.5	660	440	65	1245	830	133	2550	1700
666.6	1000	20.4	292	195	42	600	400	79.6	1140	760	167	2400	1600
1000	1500	27.5	262	175	56.5	540	360	107	1020	680	213	2040	1360
1333.2	2000	33.5	240	160	68	487	325	130	930	620	261	1875	1250
2000	3000	44	210	140	97	442	295	173	825	550	345	1650	1100

i : Ratio n1/n2      Rapport n1/n2  
 n1 : Speed n1      Vitesse sur n1  
 n2 : Speed n2      Vitesse sur n2  
 P1 : Power n1      Puissance sur n1  
 T1 : Torque on n1      Couple sur n1  
 T2 : Torque on n2      Couple sur n2  
 Tc2 : Torque on n2 (hollow bore)      Couple sur n2 (arbre creux)

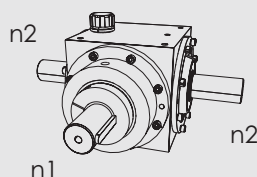

- Standard grease  Graisse standard
- Oil splash lubrication  Lubrification par barbotage
- Forced lubrication  Lubrification forcée

DIMENSIONS - Z  
ENCOMBREMENTS Z

Solid Shaft  
Arbre plein

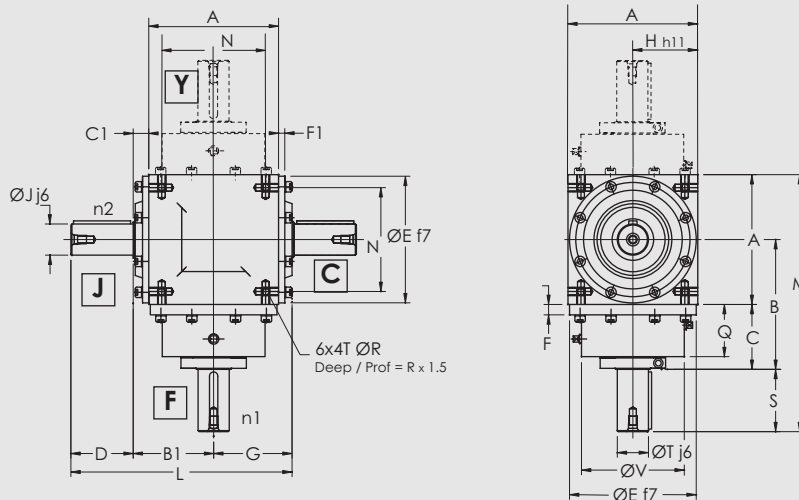

Outline Dimensions  
Dimensions des boîtiers  
mm

Size Taille	A	B1	C1	E	F1	G	H	N	R	B	C	F	Q	V	D	J	L	Weight / Masse (kg)
8	80	50	10	78	4	49	40	65	M5	80	40	8	36	62	40	20	139	3.5
10	100	62	12	98	5	61	50	80	M6	100	50	10	38	79	50	25	173	7.5
12	125	77.5	15	122	6	76	62.5	100	M8	125	62.5	10	50	99	60	30	213	12.5
16	160	100	20	155	9	98	80	125	M10	160	80	12	64	123	70	35	268	35
20	200	120	20	195	10	119	100	160	M12	200	100	15	81	149	80	45	319	50
25	250	148	23	245	13	149	125	200	M16	250	125	13	106	180	100	60	397	90
31	315	181	23.5	310	15	186	157.5	250	M16	315	157.5	15	132.5	220	125	75	492	170

Y	E	Gear Ratios Rapports 0.8-1-1.25-1.5-2			Gear Ratios Rapports 3-4-5-6		
		S	T	M	S	T	M
8		40	20	160	30	15	150
10		50	25	200	40	20	190
12		60	30	247.5	50	25	237.5
16		70	35	310	60	30	300
20		80	45	380	70	35	370
25		100	60	475	80	45	455
31		125	75	597.5	100	60	572.5

Shaft dimensions  
Dimensions des arbres

Diam.	a	b	K	L1	m	L2
15	5	5	17	25	M5	8
20	6	6	22.5	35	M6	10
25	8	7	28	45	M8	15
30	8	7	33	55	M8	15
35	10	8	38	65	M10	19
45	14	9	48.5	75	M12	24
60	18	11	64	95	M16	29
75	20	12	79.5	120	M16	29

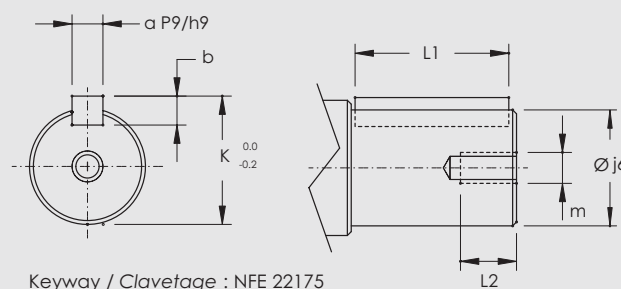

Keyway / Clavetage : NFE 22175

All data subject to change without notice  
Données susceptibles d'être modifiées sans préavis

# Z Series - Right angle Spiral Bevel Gearboxes

## Série Z - Renvois d'angle



### DIMENSIONS - Z ENCOMBREMENTS Z

Hollow bore with keyway  
Arbre creux claveté

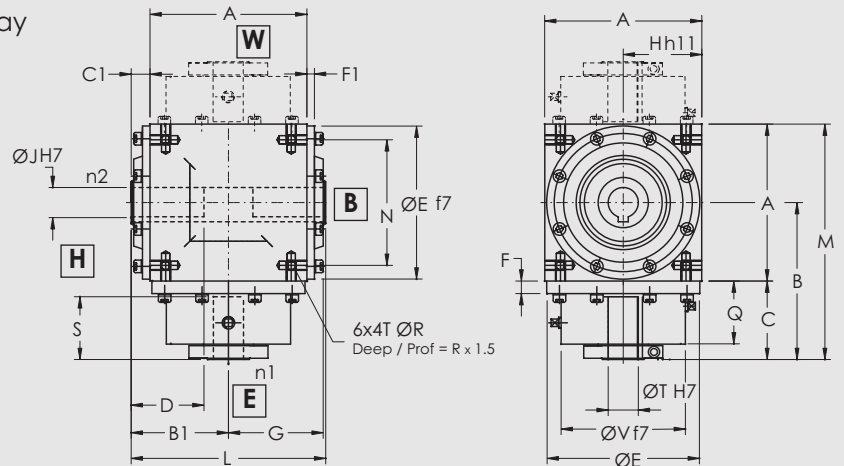

Note : the two keyways are not aligned  
Nota : les deux rainures de clavettes ne sont pas alignées

#### Outline Dimensions Dimensions des boîtiers mm

Size Taille	A	B1	C1	E	F1	G	H	N	R	B	C	F	Q	V	Weight / Masse (kg)
8	80	50	10	78	4	49	40	65	M5	80	40	8	36	62	3.5
10	0	62	12	98	5	61	50	80	M6	100	50	10	38	79	7.5
12	125	77.5	15	122	6	76	62.5	100	M8	125	62.5	10	50	98	12.5
16	160	100	20	155	9	98	80	125	M10	160	80	12	64	123	35
20	200	120	20	195	10	119	100	160	M12	200	100	15	81	149	50
25	250	148	23	245	13	149	125	200	M16	250	125	13	106	180	90
31	315	181	23.5	310	15	179	157.5	2D0	M16	315	157.5	15	132.5	220	170

[H]	[B]	Gear Ratios Rapports 0.8-1-1.25			Gear Ratios Rapports 1.5-2-3-4-5-6			[W]	[E]	Gear Ratios Rapports 0.8 1-1.25-1.5-2			Gear Ratios Rapports 3-4-5-6		
		D	J	L	D	J	L			S	T	M	S	T	M
8		35	14	100	30	14	100	08		38	14	120	39	14	120
10		45	19	124	40	19	124	10		48	19	150	39	14	150
12		58	24	155	50	24	155	12		50	24	187.5	48	19	187.5
16		70	32	200	70	32	200	16		81	32	240	64	28	240
20		90	42	240	90	42	240	20		111	42	300	82	38	300
25		100	48	296	100	48	296	25		111	48	375	111	42	375
31		120	60	362	120	60	362	31		142	60	472.5	141	48	472.5

#### Shaft dimensions Dimensions des arbres

Diam.	a	K	Gear Ratios Rapports 1-1.25-1.5-2		Gear Ratios Rapports 3-4-5-6	
			L1	L1	L1	L1
14	5	16.3	30	25		
19	6	21.8	40	30		
24	8	27.3	50	40		
28	8	31.3		60		
32	10	35.3	71			
38	10	41.3		72		
42	12	45.3	100	100		
48	14	51.8	100	100		
60	18	64.4	130			

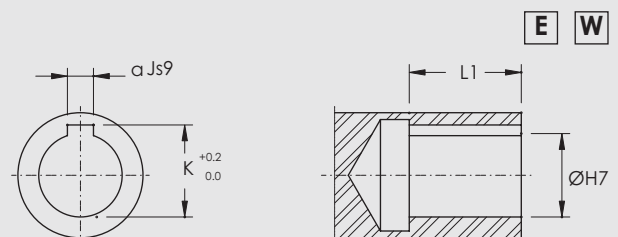

Keyway / Clavetage : NFE 22175

DIMENSIONS - Z  
ENCOMBREMENTS Z

Hollow bore with spline  
Arbre creux cannelé

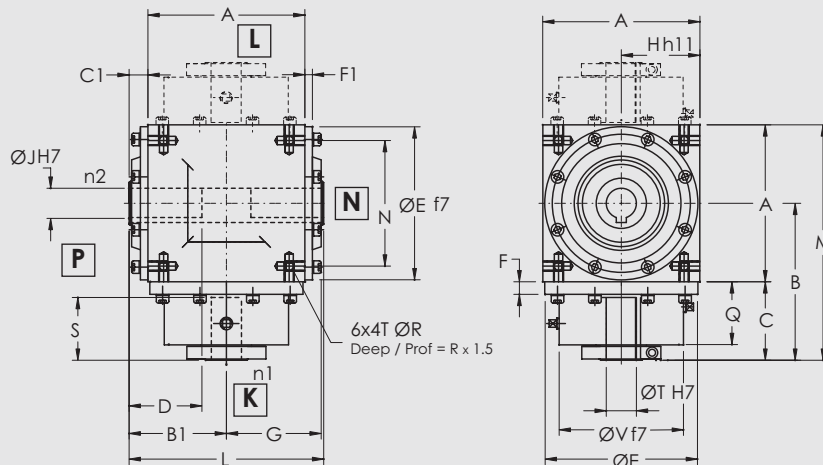

Note : the two keyways are not aligned

Nota : les deux rainures de clavettes ne sont pas alignées

Outline Dimensions  
Dimensions des boîtiers

Size Taille	A	B1	C1	E	F1	G	H	N	R	B	C	F	Q	V	Weight / Masse (kg)
8	80	50	10	78	4	49	40	65	M5	80	40	8	36	62	3.5
10	100	62	12	98	5	61	50	80	M6	100	50	10	38	79	7.5
12	125	77.5	15	122	6	76	62.5	100	M8	125	62.5	10	50	99	12.5
16	160	100	20	155	9	98	80	125	M10	160	80	12	64	123	35
20	200	120	20	195	10	119	100	160	M12	200	100	15	81	149	50
25	250	148	23	245	13	149	125	200	M16	250	125	13	106	180	90
31	315	181	23.5	310	15	179	157.5	250	M16	315	157.5	15	132.5	220	170

P	N	Gear Ratios Rapports 0.8-1-1.25			Gear Ratios Rapports 1.5-2-3-4-5-6			L	K	Gear Ratios Rapports 0.8 1-1.25-1.5-2			Gear Ratios Rapports 3-4-5-6		
		D	J	L	D	J	L			S	T	M	S	T	M
8	20	13	100	20	13	100	8	30	13	120	31	13	120		
10	45	18	124	25	18	124	10	40	18	150	39	18	150		
12	58	23	155	40	23	155	12	45	23	187.5	48	23	187.5		
16	60	28	200	35	28	200	16	60	28	240	64	28	240		
20	70	36	240	35	36	240	20	75	36	300	82	36	300		
25	90	46	296	90	46	296	25	95	46	375	95	46	375		
31	110	52	362	110	52	362	31	120	52	472.5	120	52	472.5		

Shaft dimensions  
Dimensions des arbres

Diam.	a	K	n	L1
13	3.5	16	6	20
18	5	22	6	25
23	6	28	6	35
28	7	34	6	35
36	7	42	8	40
46	9	54	8	50
52	10	60	8	60

n : No of splines / Nb de cannelures

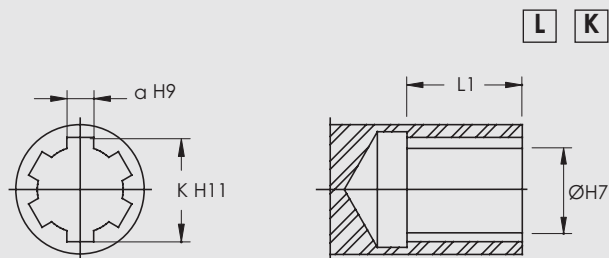

Splines / Cannelures : NFE 22131

All data subject to change without notice  
Données susceptibles d'être modifiées sans préavis

# Z Series - Right angle Spiral Bevel Gearboxes

## Série Z - Renvois d'angle



### DIMENSIONS - Z ENCOMBREMENTS Z

Hollow bore with keyway  
+ motor flange

Arbre creux claveté  
+ flasque bride

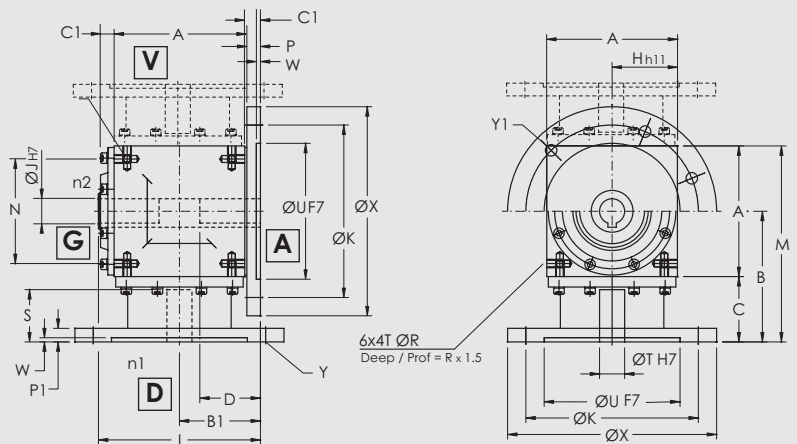

Note : the two keyways are not aligned  
Nota : les deux rainures de clavettes ne sont pas alignées

### Outline Dimensions Dimensions des boîtiers mm

Size Taille	A	B1	C1	H	N	R	B	C	X	K	U	W	Y	Y1	P1	P	Weight / Masse (kg)
8	80	50	10	40	65	M5	80	40	140	115	95	3	4xØ9	4xM6	8	9	3.5
10	100	62	12	50	80	M6	100	50	160	130	110	3.5	4xØ9	4xM8	12	12	7.5
12	125	77.5	15	62.5	100	M8	125	62.5	200	165	130	4	4xØ11	4xM10	12.5	13	12.5
16	160	100	20	80	125	M10	160	80	250	215	180	4	4xØ14	4xM12	16	18	35
20	200	120	20	100	160	M12	200	100	350	300	250	6	4xØ18	4xM16	19	19	50
25	250	148	23	125	200	M16	250	125	350	300	250	6	4xØ18	4xM16	19	23	90
31	315	181	23.5	157.5	250	M16	315	157.5	450	400	350	6	8xØ18	8xM16	25	23.5	170

G	A	Gear Ratios Rapports 0.8-1-1.25			Gear Ratios Rapports 1.5-2-3-4-5-6			V	D	Gear Ratios Rapports 0.8-1-1.25-1.5-2			Gear Ratios Rapports 3-4-5-6		
		D	J	L	D	J	L			S	T	M	S	T	M
8		35	14	100	30	14	100	8		38	14	120	30	14	20
10		45	19	124	40	19	124	10		48	19	150	39	14	150
12		58	24	155	50	24	155	12		50	24	187.5	48	19	187.5
16		70	32	200	70	32	200	16		81	32	240	64	28	240
20		90	42	240	90	42	240	20		111	42	300	82	38	300
25		100	48	296	100	48	296	25		111	48	375	111	42	375
31		120	60	362	120	60	362	31		142	60	472.5	141	48	472.5

### Shaft dimensions Dimensions des arbres

Diam.	a	K	Gear Ratios Rapports 1-1.25-1.5-2		Gear Ratios Rapports 3-4-5-6	
			L1	L1	L1	L1
14	5	16.3	30	25		
19	6	21.8	40	30		
24	8	27.3	50	40		
28	8	31.3		60		
32	10	35.3	71			
38	10	41.3		72		
42	12	45.3	100	100		
48	14	51.8	100	100		
60	18	64.4	130			

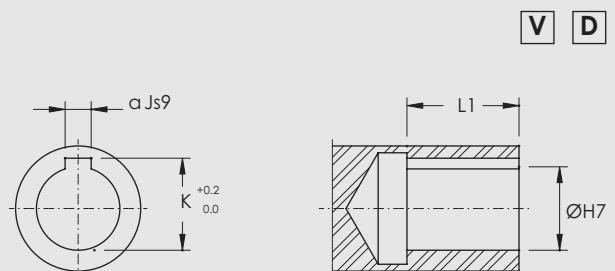

Keyway / Clavetage : NFE 22175

DIMENSIONS - Z  
ENCOMBREMENTS Z

Hollow bore with spline + motor flange

Arbre creux cannelé + Flasque bride

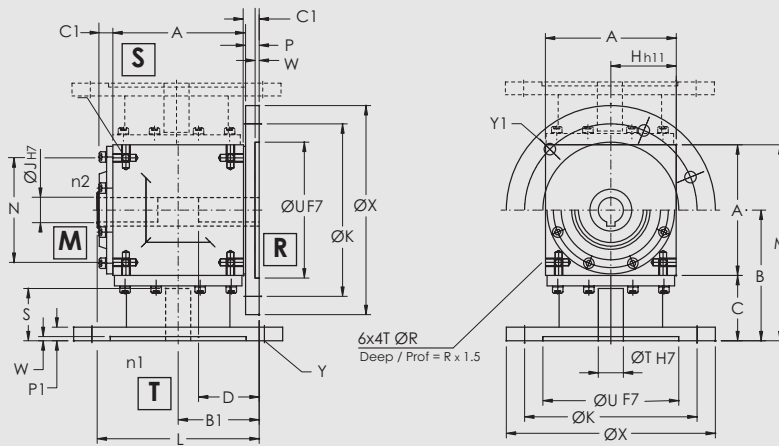

Note : the two keyways are not aligned  
Nota : les deux rainures de clavettes ne sont pas alignées

Outline Dimensions  
Dimensions des boîtiers

Size Taille	A	B1	C1	H	N	R	B	C	X	K	U	W	Y	Y1	P1	P	Weight / Masse (kg)
8	80	50	10	40	65	M5	80	40	140	115	95	3	4xØ9	4xM6	8	9	3.5
10	100	62	12	50	80	M6	100	50	160	130	110	3.5	4xØ9	4xM8	12	11	7.5
12	125	77.5	15	62.5	100	M8	125	62.5	200	165	130	4	4xØ11	4xM10	12.5	13	12.5
16	160	100	20	80	125	M10	160	80	250	215	180	4	4xØ14	4xM12	16	18	35
20	200	120	20	100	160	M12	200	100	350	300	250	6	4xØ18	4xM16	19	19	50
25	250	148	23	125	200	M16	250	125	350	300	250	6	4xØ18	4xM16	19	23	90
31	315	181	23.5	157.5	250	M16	315	157.5	450	400	350	6	8xØ18	8xM16	25	23.5	170

M	R	Gear Ratios Rapports 0.8-1-1.25			Gear Ratios Rapports 1.5-2-3-4-5-6			S	T	Gear Ratios Rapports 0.8 1-1.25-1.5-2			Gear Ratios Rapports 3-4-5-6		
		D	J	L	D	J	L			S	T	M	S	T	M
8	20	13	100	20	13	100	8	30	13	120	31	13	120		
10	45	18	124	25	18	124	10	40	18	150	39	18	150		
12	58	23	155	40	23	155	12	45	23	187.5	48	23	187.5		
16	60	28	200	35	28	200	16	60	28	240	64	28	240		
20	70	36	240	35	36	240	20	75	36	300	82	36	300		
25	90	46	296	90	46	296	25	95	46	375	95	46	375		
31	110	52	362	110	52	362	31	120	52	472.5	120	52	472.5		

Shaft dimensions  
Dimensions des arbres

Diam.	a	K	n	L1
13	3.5	16	6	20
18	5	22	6	25
23	6	28	6	35
28	7	34	6	35
36	7	42	8	40
46	9	54	8	50
52	10	60	8	60

n : No of splines / Nb de cannelures

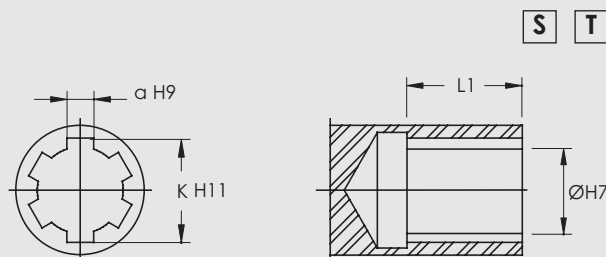

Splines / Cannelures : NFE 22131

All data subject to change without notice  
Données susceptibles d'être modifiées sans préavis



DIMENSIONS - ZR  
ENCOMBREMENTS ZR

Reinforced shaft n2  
Arbre n2 renforcé

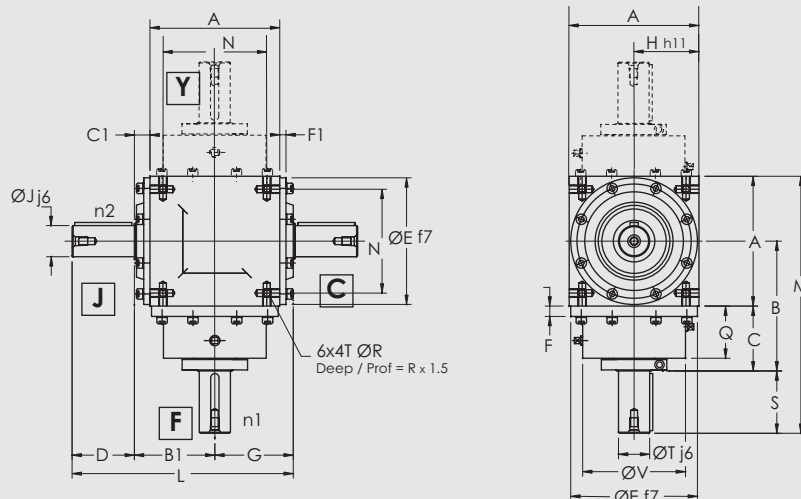

Outline Dimensions  
Dimensions des boîtiers

Size Taille	A	B1	C1	E	F1	G	H	N	R*	B	C	F	Q	V	D	J	L	Weight / Masse (kg)
12	125	77.5	15	122	6	76	62.5	100	M8	125	62.5	10	50	99	70	35	223	12.5
16	160	100	20	155	9	98	80	125	M10	160	80	12	64	123	80	50	278	35
20	200	120	20	195	10	119	100	160	M12	200	100	15	81	149	100	60	338	50
25	250	148	23	245	13	149	125	200	M16	250	125	13	102	190	125	75	419	90
31	315	181	23.5	310	15	186	157.5	250	M16	315	157.5	15	132.5	220	160	90	527	170

Y F	Gear Ratios Rapports 0.8-1-1.25-1.5-2			Gear Ratios Rapports 3-4-5-6		
	S	T	M	S	T	M
12	60	30	247.5	50	25	237.5
16	70	35	310	60	30	300
20	80	45	380	70	35	370
25	100	60	475	80	45	455
31	125	75	597.5	100	60	572.5

Shaft dimensions  
Dimensions des arbres

Diam.	a	b	K	L1	m	L2
25	8	7	28	45	M8	15
30	8	7	33	55	M8	15
35	10	8	38	65	M10	19
45	14	9	48.5	75	M12	24
50	14	9	53.5	75	M12	24
60	18	11	64	95	M16	29
75	20	12	79.5	120	M16	29
90	25	14	95	155	20	35

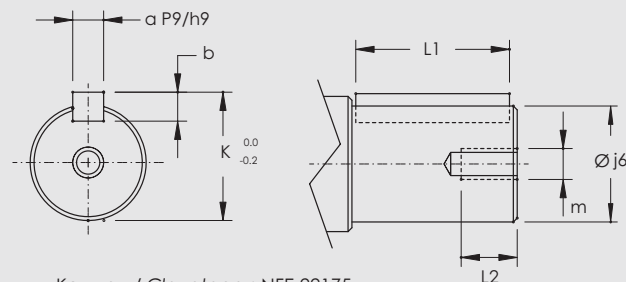

Keyway / Clavetage : NFE 22175



**DIMENSIONS - ZR**  
**ENCOMBREMENTS ZR**

Reinforced hollow bore with keyway

Arbre creux claveté renforcé

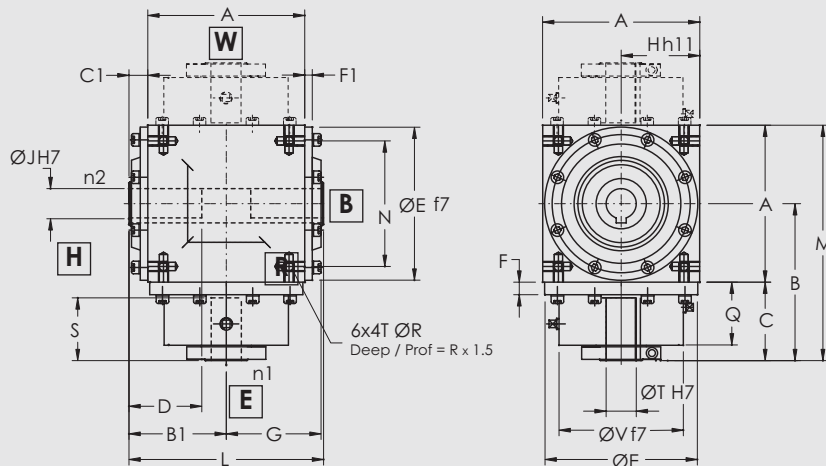

**Outline Dimensions**  
**Dimensions des boîtiers**

Size / Taille	A	B1	C1	E	I	G	H	N	R*	B	C	F	Q	V	Weight / Masse (kg)
25	250	148	23	245	13	147	125	200	M16	250	125	13	106	180	90
31	315	181	23.5	310	15	179	157.5	250	M16	315	157.5	15	132.5	220	170

[H] [B]	Gear Ratios Rappports 0.8-1-1.25			Gear Ratios Rappports 1.5-2-3-4-5-6			[W] [E]	Gear Ratios Rappports 0.8 1-1.25-1.5-2			Gear Ratios Rappports 3-4-5-6		
	D	J	L	D	J	L		S	T	M	S	T	M
25	110	55	296	110	55	296	25	120	55	375	111	48	375
31	140	75	362	140	75	362	31	142	75	472.5	141	60	472.5

**Shaft dimensions**  
**Dimensions des arbres**

Diam.	α	K	Gear Ratios Rappports	
			1-1.25-1.5-2	3-4-5-6
48	14	51.8	L1	L1
55	16	59.3	110	130
75	20	79.9	130	

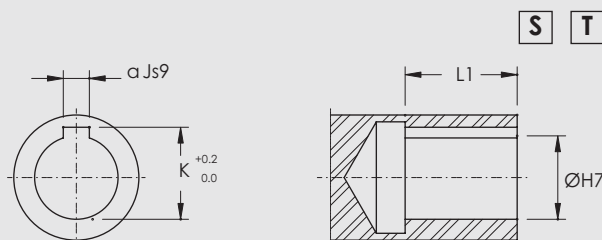

Keyway / Clavetage : NFE 22175

Max. torque on n2  
(Combinaison de multiples unités)

Couple max. sur n2  
(Montage d'appareils en série)

Size / Taille	12	16	20	25	31
Nm	350	900	1700	3400	6000

The ZR type (reinforced shaft n2) allows several bevel gearboxes to be connected together in series. The max. transmissible torques (shaft n2) are shown in the opposite table. The transmissible power remains as shown on tables p 18 to p 22.

La gamme ZR (arbre plein n2 renforcé) permet de monter plusieurs renvois d'angle en série. Les couples max. transmissibles (par l'arbre n2) sont indiqués dans le tableau ci-contre. La puissance max. transmissible demeure celle indiquée sur les tableaux p 18 à p 22.

All data subject to change without notice  
Données susceptibles d'être modifiées sans préavis



DIMENSIONS - ZT  
ENCOMBREMENTS ZT

Solid shaft  
Arbre plein

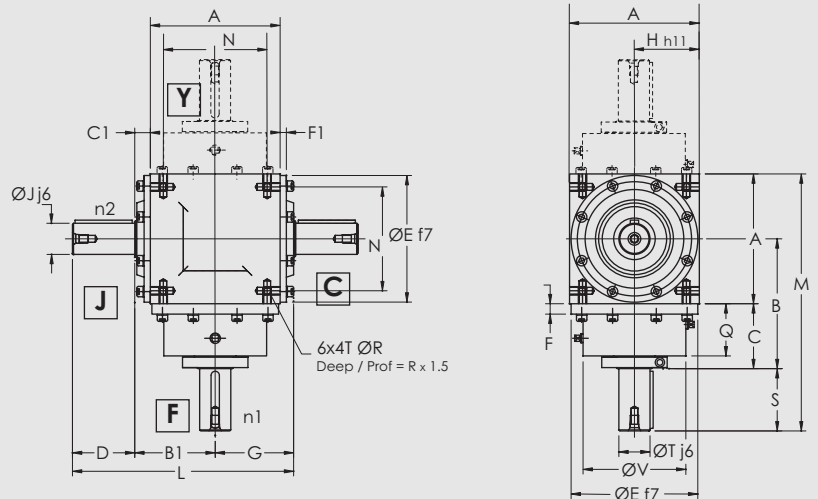

Outline Dimensions  
Dimensions des boîtiers

Size Taille	A	B1	C1	E	F1	G1	G	H	N	R*	B	C	F	Q	V	Weight / Masse (kg)
8	80	59	19	78	4	52	58	40	65	M5	80	40	8	36	62	3.5
10	100	76	26	98	5	66	74	50	80	M6	100	50	10	38	79	7.5
12	125	90	27.5	122	6	79.5	88.5	62.5	100	M8	125	62.5	10	50	99	12.5
16	160	103	23	155	9	98	101	80	125	M10	160	80	12	64	123	35
20	200	135	35	195	10	125	133	100	160	M12	200	100	15	81	149	50
25	250	159	34	245	13	153	157	125	200	M16	250	125	13	106	180	90
31	315	196	38.5	310	15	187.5	194	157.5	250	M16	315	157.5	15	132.5	220	170

  

Size Taille	D	J	L	S	T	M
8	30	15	141	40	20	160
10	40	20	182	50	25	200
12	50	25	218	60	30	247.5
16	60	30	261	70	35	310
20	70	35	336	80	45	380
25	80	45	392	100	60	475
31	100	60	483.5	125	75	597.5

Shaft dimensions  
Dimensions des arbres

Diam.	a	b	K	L1	m	L2
15	5	5	17	25	M5	8
20	6	6	22.5	35	M6	10
25	8	7	28	45	M8	15
30	8	7	33	55	M8	15
35	10	8	38	65	M10	19
45	14	9	48.5	75	M12	24
60	18	11	64	95	M16	29
75	20	12	79.5	120	M16	29

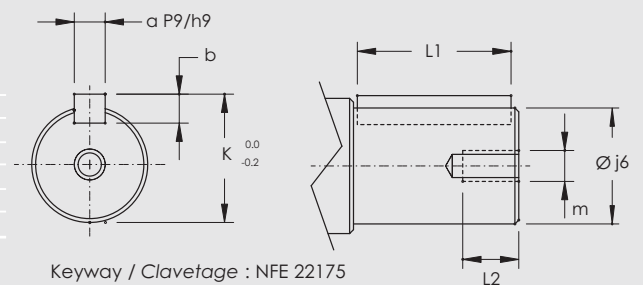

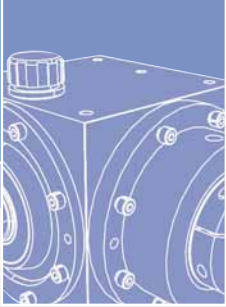

# Z Series - Right angle Spiral Bevel Gearboxes

## Série Z - Renvois d'angle

### DIMENSIONS - ZT

### ENCOMBREMENTS ZT

Hollow bore with keyway  
Arbre creux claveté

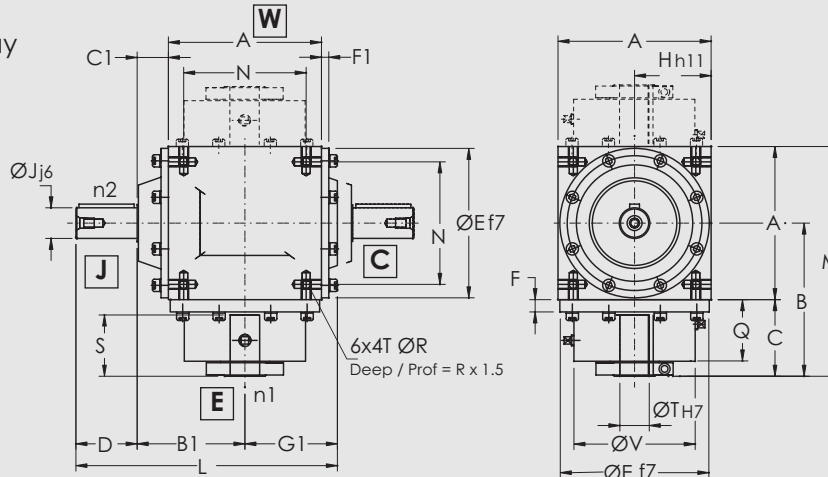

### Outline Dimensions

### Dimensions des boîtiers

Size Taille	A	B1	C1	E	F1	G1	G	H	N	R*	B	C	F	Q	V	Weight / Masse (kg)
8	80	59	19	78	4	52	58	40	65	M5	80	40	8	36	62	3.5
10	100	76	26	98	5	66	74	50	80	M6	100	50	10	38	79	7.5
12	125	90	27.5	122	6	79.5	88.5	62.5	100	M8	125	62.5	10	50	99	12.5
16	160	103	23	155	9	98	101	80	125	M10	160	80	12	64	123	35
20	200	135	35	195	10	125	133	100	160	M12	200	100	15	81	149	50
25	250	159	34	245	13	153	157	125	200	M16	250	125	13	106	180	90
31	315	196	38.5	310	15	187.5	194	157.5	250	M16	315	157.5	15	132.5	220	170

Size Taille	D	J	L	S	T	M
8	30	15	141	38	14	120
10	40	20	182	48	19	150
12	50	25	218	50	24	187.5
16	60	30	261	81	32	240
20	70	35	336	111	42	300
25	80	45	392	111	48	375
31	100	60	483.5	142	60	472.5

### Shaft dimensions

### Dimensions des arbres

Diam.	a	K	L1
14	5	16.3	30
19	6	21.8	40
24	8	27.3	50
32	10	35.3	70
42	12	45.3	100
48	14	51.8	100
60	18	64.4	130

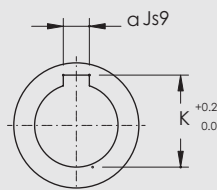

Keyway / Clavetage : NFE 22175

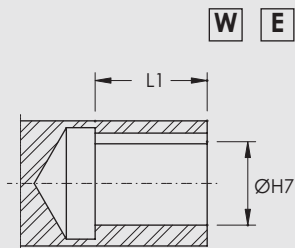

All data subject to change without notice  
Données susceptibles d'être modifiées sans préavis



DIMENSIONS - ZT  
ENCOMBREMENTS ZT

Hollow bore with spline  
Arbre creux cannelé

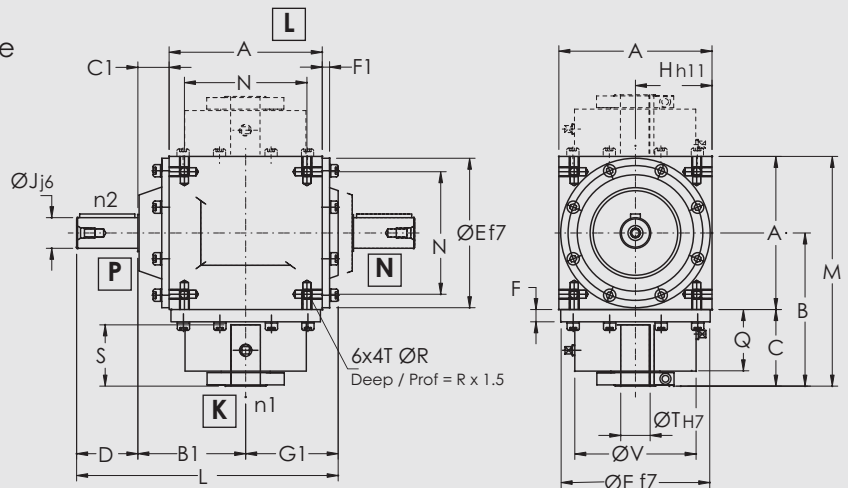

Outline Dimensions  
Dimensions des boîtiers

Size Taille	A	B1	C1	E	F1	G1	G	H	N	R*	B	C	F	Q	V	Weight / Masse (kg)
8	80	59	19	78	4	52	58	40	65	M5	80	40	8	36	62	3.5
10	100	76	26	98	5	66	74	50	80	M6	100	50	10	38	79	7.5
12	125	90	27.5	122	6	79.5	88.5	62.5	100	M8	125	62.5	10	50	99	12.5
16	160	103	23	155	9	98	101	80	125	M10	160	80	12	64	123	35
20	200	135	35	195	10	125	133	100	160	M12	200	100	15	81	149	50
25	250	159	34	245	13	153	157	125	200	M16	250	125	13	106	180	90
31	315	196	38.5	310	15	187.5	194	157.5	250	M16	315	157.5	15	132.5	220	170

Size Taille	D	J	L	S	T	M
8	30	15	141	30	13	120
10	40	20	182	40	18	150
12	50	25	218	45	23	187.5
16	60	30	261	60	28	240
20	70	35	336	75	36	300
25	80	45	392	95	46	375
31	100	60	483.5	120	52	472.5

Shaft dimensions  
Dimensions des arbres

Diam.	a	K	n	L1
13	3.5	16	6	20
18	5	22	6	25
23	6	28	6	35
28	7	34	6	35
36	7	42	8	40
46	9	54	8	50
52	10	60	8	60

n : No of splines / Nb de cannelures

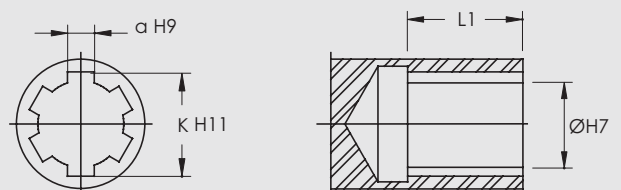

Splines / Cannelures : NFE 22131



# Z Series - Right angle Spiral Bevel Gearboxes

## Série Z - Renvois d'angle

### DIMENSIONS - ZT ENCOMBREMENTS ZT

Hollow bore with keyway  
+ motor flange  
Arbre creux claveté  
+ flasque bride

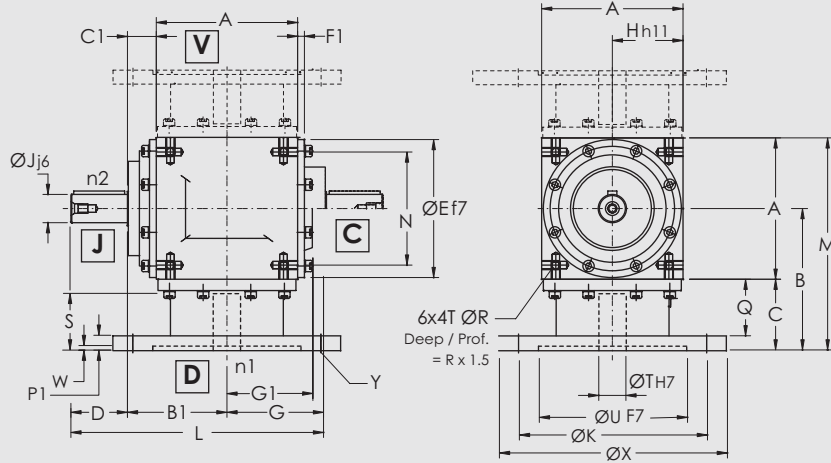

### Outline Dimensions Dimensions des boîtiers

Size Taille	A	B1	C1	E	F1	G1	G	H	N	R*	B	C	X	K	U	Weight / Masse (kg)
8	80	59	19	78	4	52	58	40	65	M5	80	40	140	115	95	3.5
10	100	76	26	98	5	66	74	50	80	M6	100	50	160	130	110	7.5
12	125	90	27.5	122	6	79.5	88.5	62.5	100	M8	125	62.5	200	165	130	12.5
16	160	103	23	155	9	98	101	80	125	M10	160	80	250	215	180	35
20	200	135	35	195	10	125	133	100	160	M12	200	100	350	300	250	50
25	250	159	34	245	13	153	157	125	200	M16	250	125	350	300	250	90
31	315	196	38.5	310	15	187.5	194	157.5	250	M16	315	157.5	450	400	350	170

Size Taille	W	Y	P1	D	J	L	S	T	M	Weight / Masse (kg)
8	3	4xØ9	8	30	15	141	38	14	120	3.5
10	3.5	4xØ9	12	40	20	190	48	19	150	7.5
12	4	4xØ11	12.5	50	25	228.5	50	24	187.5	12.5
16	4	4xØ14	16	60	30	264	81	32	240	35
20	6	4xØ18	19	70	35	338	111	42	300	50
25	6	4xØ18	19	80	45	396	111	48	375	90
31	6	8xØ18	25	100	60	483.5	142	60	472.5	170

### Shaft dimensions Dimensions des arbres

Diam.	a	K	L1
14	5	16.3	30
19	6	21.8	40
24	8	27.3	50
32	10	35.3	70
42	12	45.3	100
48	14	51.8	100
60	18	64.4	130

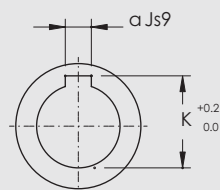

Keyway / Clavetage : NFE 22175

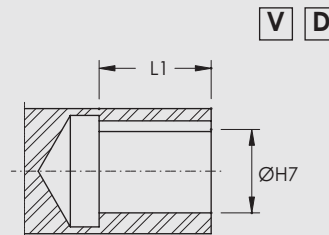

All data subject to change without notice  
Données susceptibles d'être modifiées sans préavis



DIMENSIONS - ZT  
ENCOMBREMENTS ZT

Hollow bore with spline  
+ motor flange  
Arbre creux cannelé  
+ flasque bride

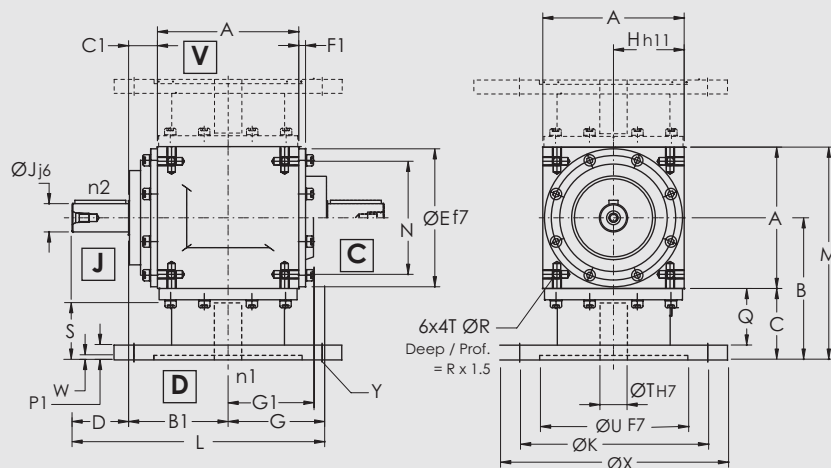

Outline Dimensions  
Dimensions des boîtiers

Size Taille	A	B1	C1	E	F1	G1	G	H	N	R*	B	C	X	K	U	Weight / Masse (kg)
8	80	59	19	78	4	52	58	40	65	M5	80	40	140	115	95	3.5
10	100	76	26	98	5	66	74	50	80	M6	100	50	160	130	110	7.5
12	125	90	27.5	122	6	79.5	88.5	62.5	100	M8	125	62.5	200	165	130	12.5
16	160	103	23	155	9	98	101	80	125	M10	160	80	250	215	180	35
20	200	135	35	195	10	125	133	100	160	M12	200	100	350	300	250	50
25	250	159	34	245	13	153	157	125	200	M16	250	125	350	300	250	90
31	315	196	38.5	310	15	187.5	194	157.5	250	M16	315	157.5	450	400	350	170

Size Taille	W	Y	P1	D	J	L	S	T	M	Weight / Masse (kg)
8	3	4xØ9	8	30	15	141	30	13	120	3.5
10	3.5	4xØ9	12	40	20	190	40	18	150	7.5
12	4	4xØ11	12.5	50	25	228.5	45	23	187.5	12.5
16	4	4xØ14	16	60	30	264	60	28	240	35
20	6	4xØ18	19	70	35	338	75	36	300	50
25	6	4xØ18	19	80	45	396	95	46	375	90
31	6	8xØ18	25	100	60	483.5	120	52	472.5	170

Shaft dimensions  
Dimensions des arbres

Diam.	a	K	n	L1
13	3.5	16	6	20
18	5	22	6	25
23	6	28	6	35
28	7	34	6	35
36	7	42	8	40
46	9	54	8	50
52	10	60	8	60

n : No of splines / Nb de cannelures

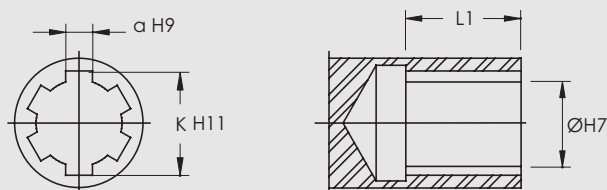

Splines / Cannelures : NFE 22131

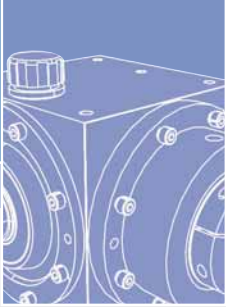

# Z Series - Right angle Spiral Bevel Gearboxes

## Série Z - Renvois d'angle

### POWER & TORQUE - ZI-ZD

### PUISSANCES ET COUPLES NOMINAUX ZI-ZD

#### i = 1

SPEED / VITESSE		SIZE / TAILLE 10			SIZE / TAILLE 12			SIZE / TAILLE 16			SIZE / TAILLE 20			SIZE / TAILLE 25			SIZE / TAILLE 31		
n1	n2	P1	T1	T2	P1	T1	T2	P1	T1	T2	P1	T1	T2	P1	T1	T2	P1	T1	T2
min-1	min-1	Kw	Nm	Nm	Kw	Nm	Nm	Kw	Nm	Nm	Kw	Nm	Nm	Kw	Nm	Nm	Kw	Nm	Nm
10	10	0.07	70	70	0.16	150	150	0.31	300	300	0.63	600	600	1.15	1100	1100	2.09	2010	2000
50	50	0.36	70	70	0.79	150	150	1.57	300	300	3.14	600	600	5.76	1100	1100	10.4	2000	2000
250	250	1.83	70	70	3.93	150	150	7.46	285	285	15.7	600	600	28.8	1100	1100	52.3	2000	2000
500	500	3.66	70	70	6.8	130	130	15	285	285	28.8	550	550	54	1030	1030	104	2000	2000
750	750	5.5	70	70	9.2	117	117	20	255	255	38.5	490	490	75	960	960	151	1920	1920
1000	1000	6.81	65	65	11.2	107	107	24.8	237	237	47	450	450	93	890	890	186	1780	1780
1500	1500	8.95	57	57	15	95	95	32.6	208	208	63	400	400	125	800	800			
2000	2000	10.7	51	51	17.8	85	85	40	190	190	76	365	365						
3000	3000	14.1	45	45															

#### i = 1.25

SPEED / VITESSE		SIZE / TAILLE 10			SIZE / TAILLE 12			SIZE / TAILLE 16			SIZE / TAILLE 20			SIZE / TAILLE 25			SIZE / TAILLE 31		
n1	n2	P1	T1	T2	P1	T1	T2	P1	T1	T2	P1	T1	T2	P1	T1	T2	P1	T1	T2
min-1	min-1	Kw	Nm	Nm	Kw	Nm	Nm	Kw	Nm	Nm	Kw	Nm	Nm	Kw	Nm	Nm	Kw	Nm	Nm
10	8	0.05	50	62.5	0.11	105	131	0.25	240	300	0.52	500	625	1.05	1000	1250	2.40	2300	2875
50	40	0.22	42	52.5	0.49	94	117	1.20	230	287	2.51	480	600	4.97	950	1187	11.5	2200	2750
250	200	1.05	40	50	2.23	85	106	5.50	210	262	9.95	380	475	22.2	850	1060	47.1	1800	2250
500	400	2.04	39	48.7	4.45	85	106	10.5	200	250	18.3	350	437	40.8	780	975	86.4	1650	2062
750	600	2.98	38	47.5	6.68	85	106	14.9	190	237	25.9	330	412	57.3	730	912	117	1500	1875
1000	800	3.98	38	47.5	8.38	80	100	18.9	180	225	33	315	394	71.2	680	850	157	1500	1875
1500	1200	5.5	35	43.7	11.3	72	90	25.1	160	200	46	293	366	94	600	750	204	1300	1625
2000	1600	6.28	30	37.5	12.6	60	75	31.4	150	187	52.3	250	312	111	530	662			
3000	2400	7.85	25	31	15.7	50	62	40.8	130	162									

#### i = 1.5

SPEED / VITESSE		SIZE / TAILLE 10			SIZE / TAILLE 12			SIZE / TAILLE 16			SIZE / TAILLE 20			SIZE / TAILLE 25			SIZE / TAILLE 31		
n1	n2	P1	T1	T2	P1	T1	T2	P1	T1	T2	P1	T1	T2	P1	T1	T2	P1	T1	T2
min-1	min-1	Kw	Nm	Nm	Kw	Nm	Nm	Kw	Nm	Nm	Kw	Nm	Nm	Kw	Nm	Nm	Kw	Nm	Nm
10	6.6	0.057	55	82	0.10	100	150	0.24	233	350	0.49	466	700	0.87	833	1250	1.74	1666	2500
50	33.3	0.28	55	82	0.52	100	150	1.22	233	350	2.44	466	700	4.36	833	1250	8.72	1666	2500
250	166.6	1.44	55	82	2.62	100	150	6.10	233	350	12.2	466	700	21.8	833	1250	43.6	1666	2500
500	333.3	2.88	55	82	5.24	100	150	12.2	233	350	24.4	466	700	43.6	833	1250	87.2	1666	2500
750	500	4.32	55	82	7.85	100	150	16.7	213	319	34.5	440	660	65	830	1245	130	1666	2500
1000	666.6	5.76	55	82	10.1	97	145	20.4	195	292	42	400	600	79.6	760	1140	174	1600	2400
1500	1000	7.70	49	73	13.5	86	129	27.5	175	262	56.5	360	540	107	680	1020	213	1360	2040
2000	1333	9.21	44	66	16.5	79	118	33.5	160	240	68	325	487	130	620	930	261	1250	1875
3000	2000	12.2	39	58	22	70	105	44	140	210	92	295	442						

i : Ratio n1/n2  
 n1 : Speed n1  
 n2 : Speed n2  
 P1 : Power n1  
 T1 : Torque on n1  
 T2 : Torque on n2

Rapport n1/n2  
 Vitesse sur n1  
 Vitesse sur n2  
 Puissance sur n1  
 Couple sur n1  
 Couple sur n2

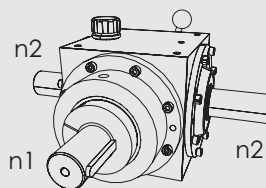

- Standard grease   
Graisse standard
- Oil splash lubrication   
Lubrification par barbotage
- Forced lubrication   
Lubrification forcée

All data subject to change without notice  
 Données susceptibles d'être modifiées sans préavis



### POWER & TORQUE - ZI-ZD PUISSANCES ET COUPLES NOMINAUX ZI-ZD

**TO BE NOTED : Positions K-N-P only !**

- No rotation direction to specify for the ZI versions
- Disengagement when stationary (no load applied)
- Design with lever on the top face available (on request)

**A NOTER : Positions K-N-P seulement !**

- Pas de sens de rotation à préciser pour versions ZI
- Débrayable à l'arrêt sans charge
- Possibilité de mettre le levier sur la face supérieure (sur demande)

#### i = 2

SPEED / VITESSE		SIZE / TAILLE 10			SIZE / TAILLE 12			SIZE / TAILLE 16			SIZE / TAILLE 20			SIZE / TAILLE 25			SIZE / TAILLE 31		
n1 min-1	n2 min-1	P1 Kw	T1 Nm	T2 Nm	P1 Kw	T1 Nm	T2 Nm	P1 Kw	T1 Nm	T2 Nm	P1 Kw	T1 Nm	T2 Nm	P1 Kw	T1 Nm	T2 Nm	P1 Kw	T1 Nm	T2 Nm
10	5	0.06	55	110	0.1	100	200	0.21	200	400	0.5	480	960	1.05	1000	2000	1.88	1800	3600
50	25	0.24	42	90	0.5	95	190	0.99	190	380	2.15	410	820	4.35	830	1660	8.37	1600	3200
250	125	1.1	42	84	2.17	85	166	4.71	180	360	10.2	390	780	18.3	700	1400	36.6	1400	2800
500	250	2.2	42	84	4.19	80	160	8.9	170	340	18.3	350	700	34	650	1300	68	1300	2600
750	375	3.3	42	84	6.13	78	156	15.7	165	330	25	320	640	47	600	1200	98	1250	2500
1000	500	4.4	42	84	7.85	73	146	15.7	150	300	31	295	590	58	560	1120	125	1200	2400
1500	750	6.28	40	80	11	65	130	21	135	270	40.8	260	520	78	500	1000	157	1000	2000
2000	1000	7.96	38	76	13.6	60	120	26.2	125	250	50	240	480	92	440	880	188	900	1800
3000	1500	11.3	36	72	18.2	52	104	36	115	230	66	210	420	119	380	760			

#### i = 3

SPEED / VITESSE		SIZE / TAILLE 10			SIZE / TAILLE 12			SIZE / TAILLE 16			SIZE / TAILLE 20			SIZE / TAILLE 25			SIZE / TAILLE 31		
n1 min-1	n2 min-1	P1 Kw	T1 Nm	T2 Nm	P1 Kw	T1 Nm	T2 Nm	P1 Kw	T1 Nm	T2 Nm	P1 Kw	T1 Nm	T2 Nm	P1 Kw	T1 Nm	T2 Nm	P1 Kw	T1 Nm	T2 Nm
10	3.33	0.03	25	75	0.06	57	171	0.10	95	285	0.24	230	690	0.47	450	1350	0.89	850	2550
50	16.6	0.13	24	72	0.30	57	171	0.50	95	285	1.13	215	645	2.09	400	1200	3.92	750	2250
250	83.3	0.58	22	66	1.31	50	150	2.20	84	252	5.1	195	585	9.01	344	1032	18.3	700	2100
500	166.6	0.99	19	57	2.20	42	126	3.82	73	219	8.9	170	510	15.7	300	900	31.4	600	1800
750	250	1.34	17	51	3.22	41	123	5.65	72	216	12.9	165	495	21.2	270	810	43.2	550	1650
1000	333.3	1.68	16	48	4.19	40	120	7.33	70	210	16.8	160	480	27.2	260	780	55.5	530	1590
1500	500	2.51	16	48	5.18	33	99	10.2	65	195	23.6	150	450	37.7	240	720	75.4	480	1440
2000	666.6	2.93	14	42	6.49	31	93	12.1	58	174	28.3	135	405	47.8	228	684	94.2	450	1350
3000	1000	4.08	13	39	9.42	30	90	15.7	50	150	39.3	125	375	67.3	214	642			

i : Ratio n1/n2      Rapport n1/n2  
 n1 : Speed n1      Vitesse sur n1  
 n2 : Speed n2      Vitesse sur n2  
 P1 : Power n1      Puissance sur n1  
 T1 : Torque on n1      Couple sur n1  
 T2 : Torque on n2      Couple sur n2

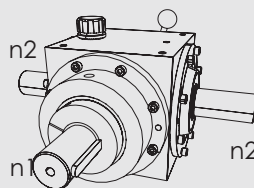

Standard grease      Graisse standard  
 Oil splash lubrication      Lubrification par barbotage  
 Forced lubrication      Lubrification forcée



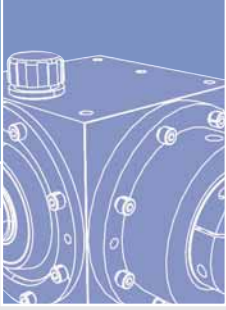

# Z Series - Right angle Spiral Bevel Gearboxes

## Série Z - Renvois d'angle

### DIMENSIONS - ZI-ZD

### ENCOMBREMENTS ZI-ZD

Solid shaft  
Arbre plein

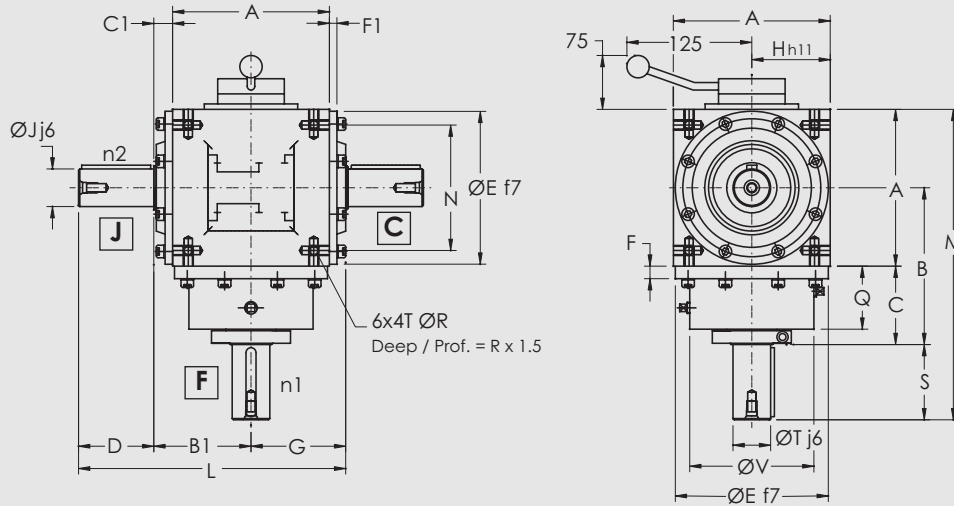

### Outline Dimensions Dimensions des boîtiers

Size Taille	A	B1	C1	E	F1	G	H	N	R*	B	C	F	Q	V	D	J	L	Weight / Masse (kg)
10	100	62	12	98	5	61	50	80	M6	100	50	10	38	79	50	25	173	8.25
12	125	77.5	15	122	6	76	62.5	100	M8	125	62.5	10	50	99	60	30	213	13.75
16	160	100	20	155	9	98	80	125	M10	160	80	12	64	123	70	35	268	37.5
20	200	120	20	195	10	119	100	160	M12	200	100	15	81	149	80	45	318	52.5
25	250	148	23	245	13	149	125	200	M16	250	125	13	106	180	100	60	394	94.5
31	315	181	23.5	310	15	186	157.5	250	M16	315	157.5	15	132.5	220	125	75	492	178.5

F	Gear Ratios Rapports 1-1.25-1.5-2			Gear Ratios Rapports 3		
	S	T	M	S	T	M
10	50	25	200	40	20	190
12	60	30	247.5	50	25	237.5
16	70	35	310	60	30	300
20	80	45	380	70	35	370
25	100	60	475	80	45	455
31	125	75	597.5	100	60	572.5

### Shaft dimensions Dimensions des arbres

Diam.	a	b	K	L1	m	L2
20	6	6	22.5	35	M6	10
25	8	7	28	45	M8	15
30	8	7	33	55	M8	15
35	10	8	38	65	M10	19
45	14	9	48.5	75	M12	24
60	18	11	64	95	M16	29
75	20	12	79.5	120	M16	29

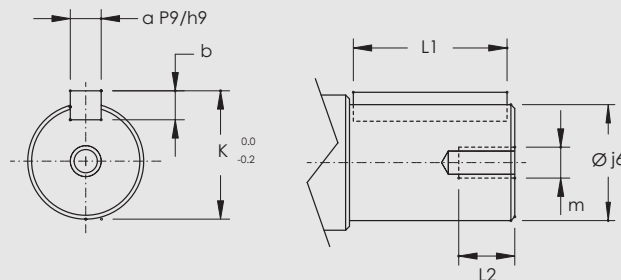

Keyway / Clavetage : NFE 22175

All data subject to change without notice  
Données susceptibles d'être modifiées sans préavis

# Z Series - Right angle Spiral Bevel Gearboxes

## Série Z - Renvois d'angle



Z Series Série Z

### DIMENSIONS - ZI-ZD ENCOMBREMENTS ZI-ZD

Hollow bore with keyway  
Arbre creux claveté

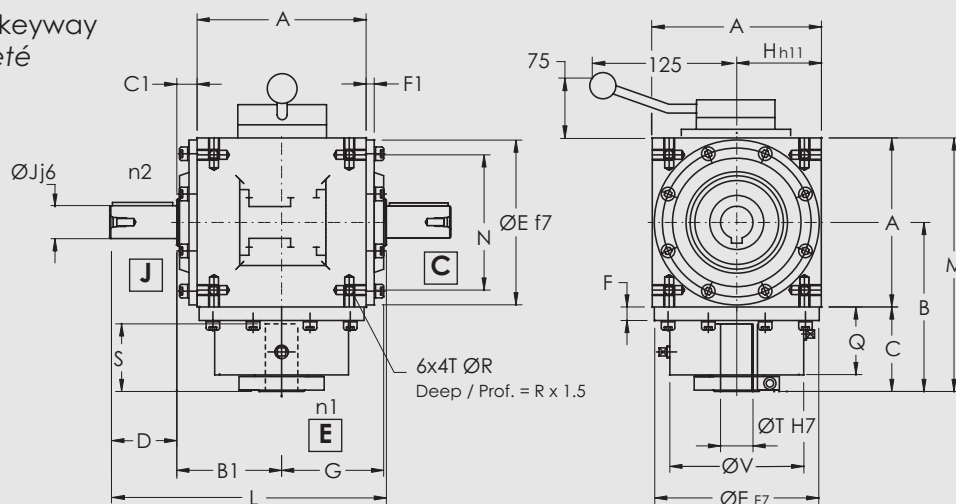

#### Outline Dimensions Dimensions des boîtiers

Size Taille	A	B1	C1	E	F1	G	H	N	R*	B	C	F	Q	V	D	J	L	Weight / Masse (kg)
10	100	62	12	98	5	61	50	80	M6	100	50	10	38	79	50	25	173	8.25
12	125	77.5	15	122	6	76	62.5	100	M8	125	62.5	10	50	99	60	30	213	13.75
16	160	100	20	155	9	98	80	125	M10	160	80	12	64	123	70	35	268	37.5
20	200	120	20	195	10	119	100	160	M12	200	100	15	81	149	80	45	318	52.5
25	250	148	23	245	13	149	125	200	M16	250	125	13	106	180	100	60	394	94.5
31	315	181	23.5	310	15	186	157.5	250	M16	315	157.5	15	132.5	220	125	75	492	178.5

E	Gear Ratios Rapports 1-1.25-1.5-2			Gear Ratios Rapports 3		
	S	T	M	S	T	M
10	48	19	150	39	14	150
12	50	24	187.5	48	19	187.5
16	81	32	240	64	28	240
20	111	42	300	82	38	300
25	111	48	375	111	42	375
31	142	60	472.5	111	48	472.5

#### Shaft dimensions Dimensions des arbres

Diam.	a	K	Gear Ratios Rapports 1-1.25-1.5-2		Gear Ratios Rapports 3-4-5-6	
			L1	L1	L1	L1
14	5	16.3	30	25		
19	6	21.8	40	30		
24	8	27.3	50	40		
28	8	31.3		60		
32	10	35.3	71			
38	10	41.3		72		
42	12	45.3	100	100		
48	14	51.8	100	100		
60	18	64.4	130			

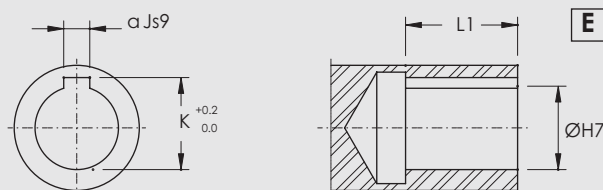

Keyway / Clavetage : NFE 22175

See solid shaft dimensions p 38  
Dimensions des arbres pleins p 38



# Z Series - Right angle Spiral Bevel Gearboxes

## Série Z - Renvois d'angle

### DIMENSIONS - ZI-ZD

### ENCOMBREMENTS ZI-ZD

Hollow bore with spline  
Arbre creux cannelé

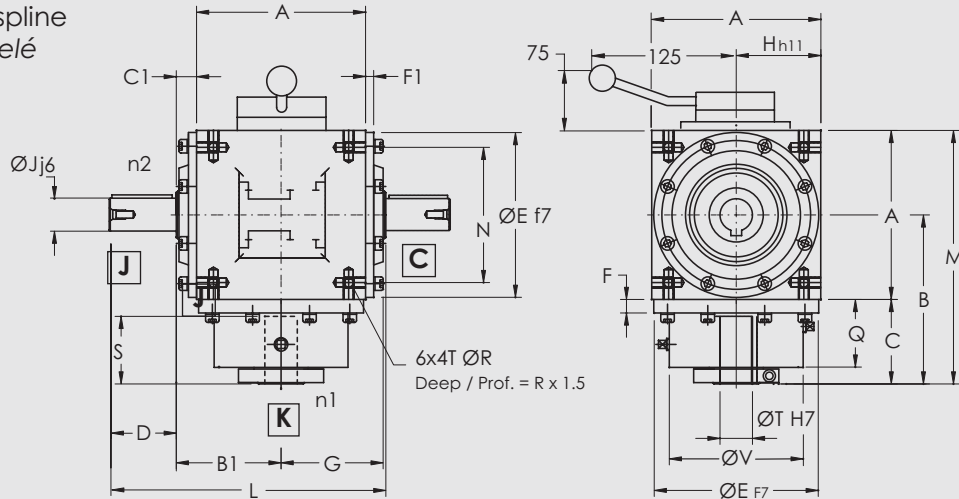

### Outline Dimensions Dimensions des boîtiers

Size Taille	A	B1	C1	E	F1	G	H	N	R*	B	C	F	Q	V	D	J	L	Weight / Masse (kg)
10	100	62	12	98	5	61	50	80	M6	100	50	10	38	79	50	25	173	8.25
12	125	77.5	15	122	6	76	62.5	100	M8	125	62.5	10	50	99	60	30	213	13.75
16	160	100	20	155	9	98	80	125	M10	160	80	12	64	123	70	35	268	37.5
20	200	120	20	195	10	119	100	160	M12	200	100	15	81	149	80	45	318	52.5
25	250	148	23	245	13	149	125	200	M16	250	125	13	106	180	100	60	394	94.5
31	315	181	23.5	310	15	186	157.5	250	M16	315	157.5	15	132.5	220	125	75	492	178.5

K	Gear Ratios Rapports 1-1.25-1.5-2			Gear Ratios Rapports 3		
	S	T	M	S	T	M
10	40	18	150	39	18	150
12	45	23	187.5	48	23	187.5
16	60	28	240	64	28	240
20	75	36	300	82	36	300
25	95	46	375	95	46	375
31	120	52	472.5	120	52	472.5

### Shaft dimensions Dimensions des arbres

Diam.	a	K	n	L1
18	5	22	6	25
23	6	28	6	35
28	7	34	6	35
36	7	42	8	40
46	9	54	8	50
52	10	60	8	60

n : No of splines / Nb de cannelures

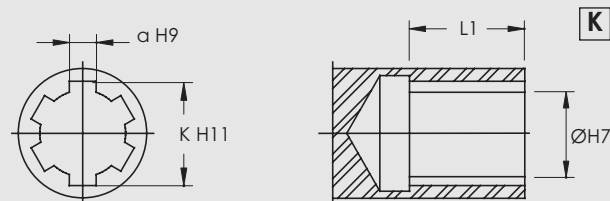

Splines / Cannelures : NFE 22131

See solid shaft dimensions p 38  
Dimensions des arbres pleins p 38

All data subject to change without notice  
Données susceptibles d'être modifiées sans préavis



**DIMENSIONS - ZI-ZD**  
**ENCOMBREMENTS ZI-ZD**

Hollow bore with keyway  
+ motor flange

Arbre creux claveté  
+ flasque bride

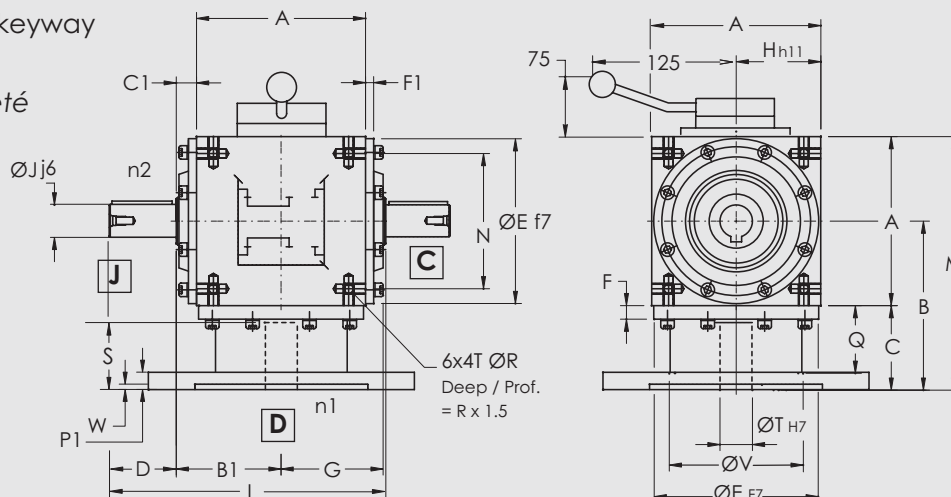

**Outline Dimensions**  
**Dimensions des boîtiers**

Size Taille	A	BI	CI	E	FI	G	H	N	R*	B	C	X	K	U	W	Y	P1	D	J	L	Weight / Masse (kg)
10	100	62	12	98	5	61	50	80	M6	100	50	160	130	110	3.5	4xØ9	12	50	25	173	8.25
12	125	77.5	15	122	6	76	62.5	100	M8	125	62.5	200	165	130	4	4xØ11	12.5	60	30	213	13.75
16	160	100	20	155	9	98	80	125	M10	60	80	250	215	180	4	4xØ14	16	70	35	268	37.5
20	200	120	20	195	10	119	100	160	M12	200	100	350	300	250	6	4xØ18	19	80	45	318	52.5
25	250	148	23	245	13	149	125	200	M16	250	125	350	300	250	6	4xØ18	19	100	60	394	94.5
31	315	181	23.5	310	15	186	157.5	250	M16	315	157.5	450	400	350	6	8xØ18	25	125	75	492	178.5

D	Gear Ratios Rapports 1-1.25-1.5-2			Gear Ratios Rapports 3		
	S	T	M	S	T	M
10	48	19	150	39	14	150
12	50	24	187.5	48	19	187.5
16	81	32	240	64	28	240
20	111	42	300	82	38	300
25	111	48	375	111	42	375
31	142	60	472.5	111	48	472.5

**Shaft dimensions**  
**Dimensions des arbres**

Diam.	a	K	Gear Ratios Rapports 1-1.25-1.5-2		Gear Ratios Rapports 3-4-5-6	
			L1	L1	L1	L1
14	5	16.3	30	25		
19	6	21.8	40	30		
24	8	27.3	50	40		
28	8	31.3		60		
32	10	35.3	71			
38	10	41.3		72		
42	12	45.3	100	100		
48	14	51.8	100	100		
60	18	64.4	130			

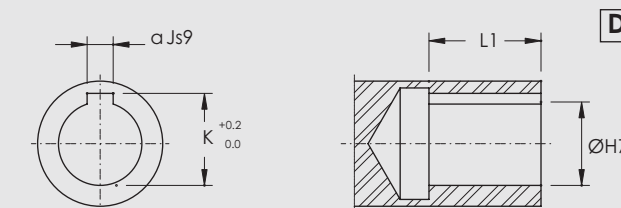

Keyway / Clavetage : NFE 22175

See solid shaft dimensions p 38  
Dimensions des arbres pleins p 38



# Z Series - Right angle Spiral Bevel Gearboxes

## Série Z - Renvois d'angle

### DIMENSIONS - ZI-ZD

### ENCOMBREMENTS ZI-ZD

Hollow bore with spline  
+ motor flange

Arbre creux cannelé  
+ flasque bride

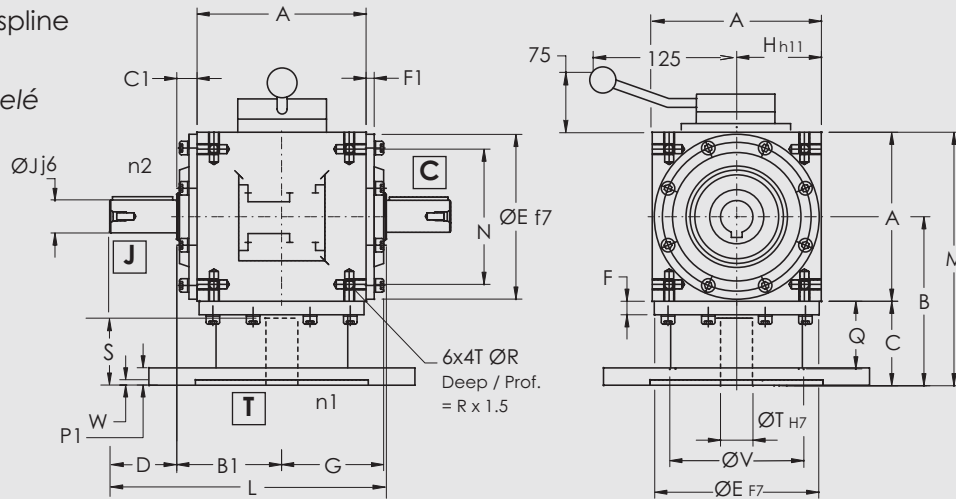

### Outline Dimensions

### Dimensions des boîtiers

Size Taille	A	Bl	Cl	E	Fl	G	H	N	R*	B	C	X	K	U	W	Y	P1	D	J	L	Weight / Masse (kg)
10	100	62	12	98	5	61	50	80	M6	100	50	160	130	110	3.5	4xØ9	12	50	25	173	8.25
12	125	77.5	15	122	6	76	62.5	100	M8	125	62.5	200	165	130	4	4xØ11	12.5	60	30	213	13.75
16	160	100	20	155	9	98	80	125	M10	60	80	250	215	180	4	4xØ14	16	70	35	268	37.5
20	200	120	20	195	10	119	100	160	M12	200	100	350	300	250	6	4xØ18	19	80	45	318	52.5
25	250	148	23	245	13	149	125	200	M16	250	125	350	300	250	6	4xØ18	19	100	60	394	94.5
31	315	181	23.5	310	15	186	157.5	250	M16	315	157.5	450	400	350	6	8xØ18	25	125	75	492	178.5

T	Gear Ratios Rapports 1-1.25-1.5-2			Gear Ratios Rapports 3		
	S	T	M	S	T	M
10	40	18	150	39	18	150
12	45	23	187.5	48	23	187.5
16	60	28	240	64	28	240
20	75	36	300	82	36	300
25	95	46	375	95	46	375
31	120	52	472.5	120	52	472.5

### Shaft dimensions

### Dimensions des arbres

Diam.	a	K	n	L1
18	5	22	6	25
23	6	28	6	35
28	7	34	6	35
36	7	42	8	40
46	9	54	8	50
52	10	60	8	60

n : No of splines / Nb de cannelures

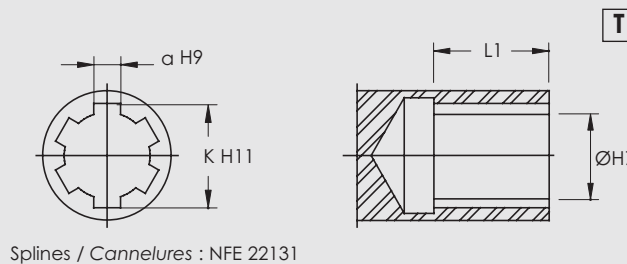

Splines / Cannelures : NFE 22131

See solid shaft dimensions p 38  
Dimensions des arbres pleins p 38

All data subject to change without notice  
Données susceptibles d'être modifiées sans préavis



OTHER FLANGES DIMENSIONS - Z  
GAMME DE FLASQUES MOTEUR Z

Hollow bore with keyway  
+ optional motor flange

Arbre creux claveté  
+ flasque bride possible

**CAUTION :**  
Non standard versions,  
consult your supplier !

**ATTENTION :**  
Versions hors standard,  
nous consulter !

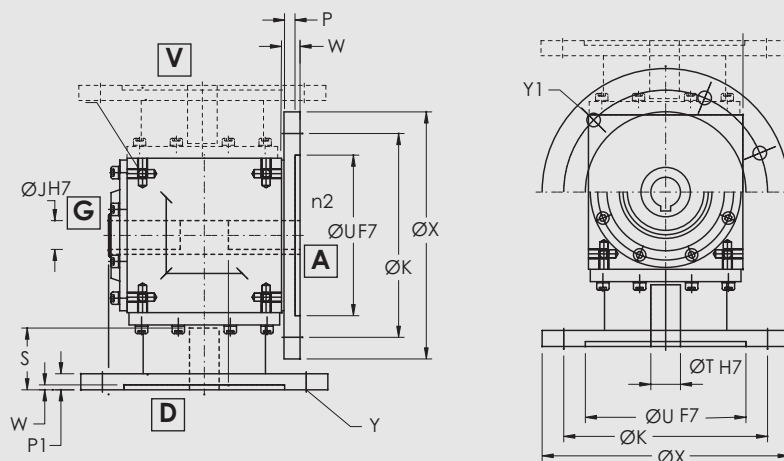

Shafts Dimensions  
Dimensions des arbres

Size Taille	ØT H7 x S Gear ratios rapports 0.8-1-1.25-1.5-2			ØT H7 x S Gear ratios rapports 3-4-5-6			ØJ H7 x D			ØX Flange Bride				P	P1			
	8	10	12	14	16	18	20	25	31	120	140	160	200					
8	14x30	11x25	9x20	14x30	11x25	9x20	14x30	11x25	9x20	160	140	120	9	8				
10	19x40	14x30	11x25	14x30	11x25	9x20	19x40	14x30	11x25	200	160	140	120	11	12			
12	24x50	19x40	14x30	19x40	14x30	11x25	24x50	19x40	14x30	200	160	140	13	12.5				
16	32x70	28x60	24x50	28x60	24x50	19x40	32x70	28x60	24x50	300	250	200	18	16				
20	42x110	38x80	28x60	24x50	38x80	28x60	24x50	19x40	42x110	38x80	28x60	24x50	350	300	250	200	19	19
25	55x110	48x110	42x110	38x80	48x110	42x110	38x80	28x60	55x110	48x110	42x110	38x80	450	400	350	300	23	19
31	75x140	60x140	55x110	48x110	60x140	55x110	48x110	42x110	75x140	60x140	55x110	48x110	550	450	400	350	23.5	25

Flange dimensions  
Dimensions des brides

ØX	K	U F7	W	Y	Y1	ØX	K	U F7	W	Y	Y1
120	100	80	4	4xØ9	4xM6	300	265	230	5	4xØ14	4xM12
140	115	95	4	4xØ9	4xM8	350	300	250	6	4xØ18	4xM16
160	130	110	4	4xØ9	4xM8	400	350	300	6	8xØ18	8xM16
200	165	130	4	4xØ11	4xM10	450	400	350	6	8xØ18	8xM16
250	215	180	5	4xØ14	4xM12	550	500	450	6	8xØ18	8xM16

Shaft dimensions  
Dimensions des arbres

Diam.	a	K	L1
9	3	10.4	20
11	4	12.8	25
14	5	16.3	30
19	6	21.8	40
24	8	27.3	50
28	8	31.3	60
32	10	35.3	70
38	10	41.3	80
42	12	45.3	110
48	14	51.8	110
55	16	59.3	110
60	18	64.4	130
75	20	79.9	130

Note : by design, keyways A and B cannot be not aligned  
Nota : les rainures de clavettes A et B ne sont pas alignées

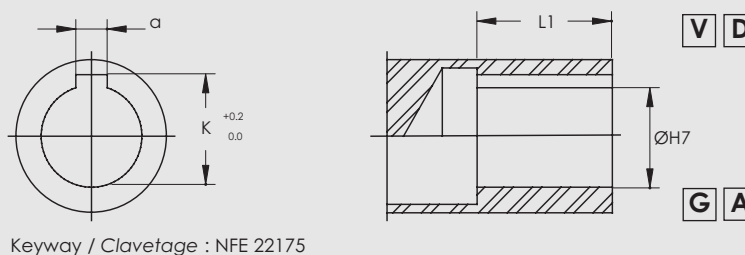

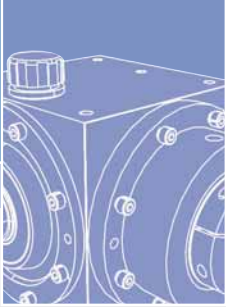

TRI-DIRECTIONAL - ZX  
TRI-DIRECTIONNEL - ZX

Based on the modular design of the Z-Series, all sizes can be offered with shafts in three axes.

This allows the simplification of designs requiring one input and two outputs at right angle to each other.

Consult your supplier.

Grâce à sa conception modulaire, la série Z permet d'offrir toutes ses tailles en version tri-directionnelle.

Cette possibilité offre une solution simple pour tous les mécanismes nécessitant une entrée et deux sorties à angle droit entre elles.

Nous consulter

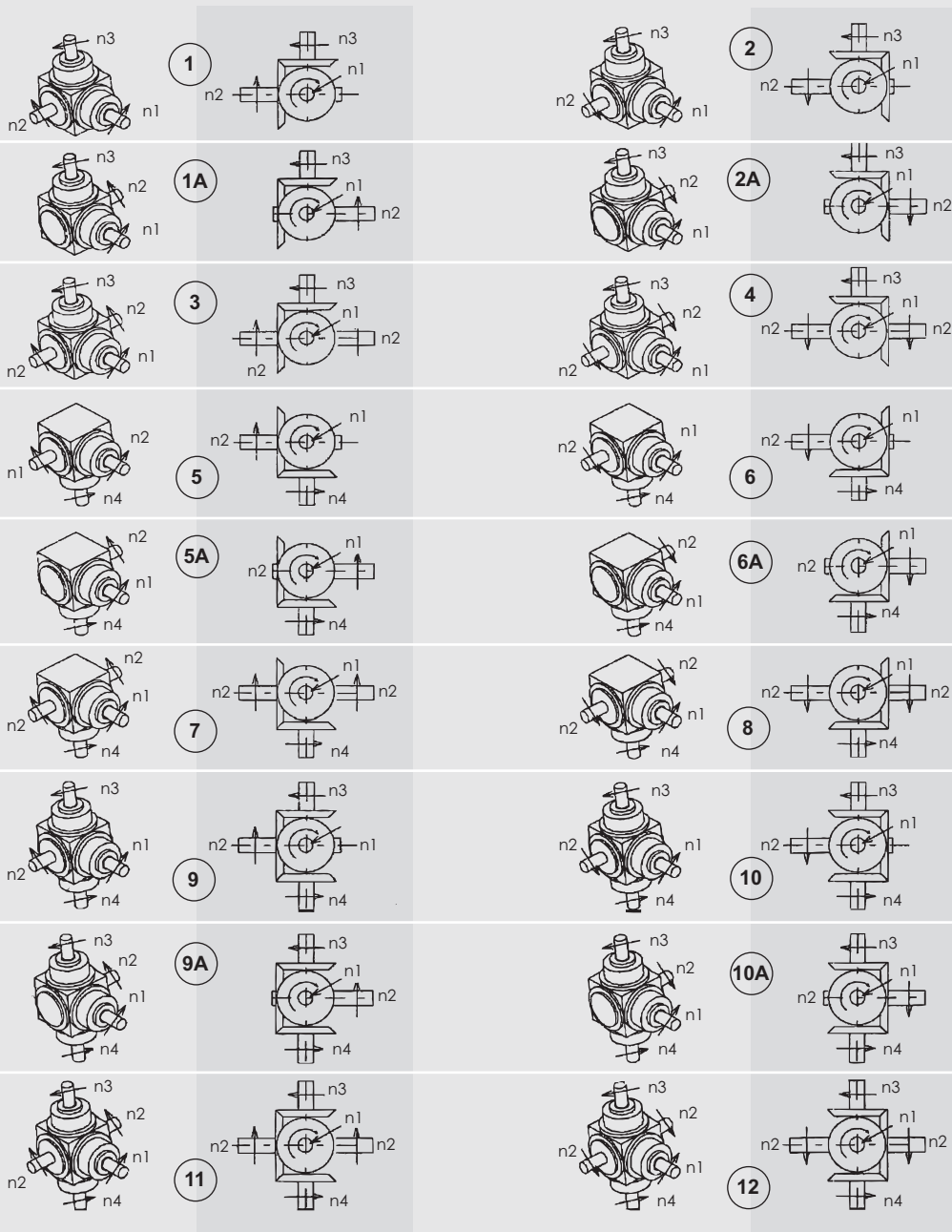

$$i = \frac{n1}{n2} = \frac{n3}{n2} = \frac{n4}{n2} = 1.25 - 1.5 - 2 - 3 - 4 - 5 - 6$$

All data subject to change without notice  
Données susceptibles d'être modifiées sans préavis

# Z Series - Right angle Spiral Bevel Gearboxes

## Série Z - Renvois d'angle



### FILL, LEVEL & DRAIN POSITION - Z & ZR POSITION DES ORIFICES - Z & ZR

Mounting position K  
Position de fonctionnement K

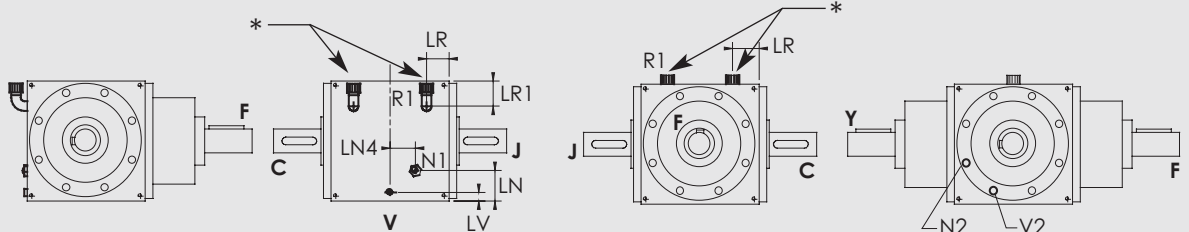

Valid for mounting surfaces R, S, T, U or X  
Valable pour faces de fixation R, S, T, U ou X

Valid for mounting surfaces Z  
Valable pour faces de fixation Z

\*opposite to the crown / opposé à la couronne

Mounting position N or P  
Position de fonctionnement N ou P

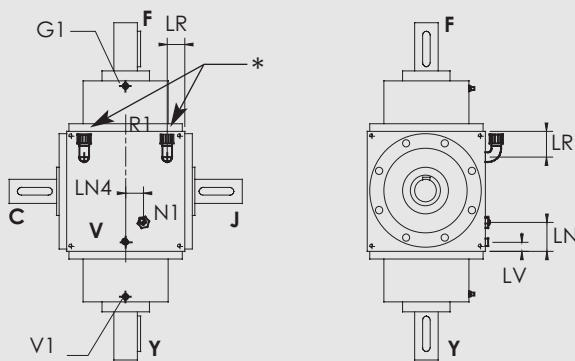

Valid for mounting surfaces R, S, T, U, X or Z  
Valable pour faces de fixation R, S, T, U, X ou Z

Mounting position L or M  
Position de fonctionnement L ou M

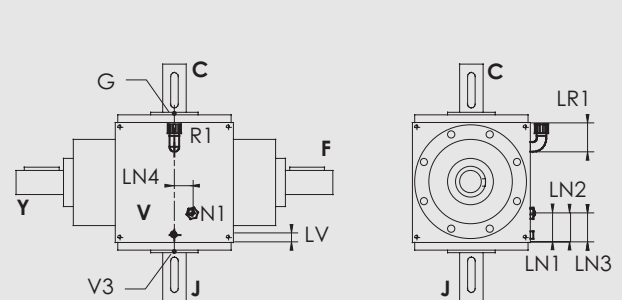

Valid for mounting surfaces R, S, T, U, X or Z  
Valable pour faces de fixation R, S, T, U, X ou Z

\*opposite to the crown / opposé à la couronne

Size Taille	ØV	LV	ØV1	ØV2	ØV3	ØN1	*LN	*LN1	*LN2	*LN3	LN4	ØN2	ØR1	LR	LRI	ØG	ØG1
Z08	1/4"	12	1/8"	M4		1/4"	23	23	28	35	15	M4	1/4"	17	35		
Z10	1/4"	14	1/8"	M5	M6	1/4"	30	30	35	45	15	M5	1/4"	17	35	M6	1/8"
Z12	3/8"	17	1/8"	M6	M6	3/8"	35	35	42	55	15	M6	3/8"	22	50	M6	1/8"
Z16	3/8"	19	1/8"	M8	M6	3/8"	45	45	55	72	0	M8	3/8"	27	50	M6	1/8"
Z20	1/2"	23	1/8"	M8	M6	1/2"	58	58	70	90	0	M8	1/2"	50	55	M6	1/8"
Z25	1/2"	25	1/8"	M10	M6	1/2"	75	75	90	112	0	M10	1/2"	60	55	M6	1/8"
Z31	1/2"	30	1/8"	M12	M6	1/2"	110	110	115	141	0	M12	1/2"	90	55	M6	1/8"

\*LN = all ratios

\*LN1 = for ratio 0.8 - 1 - 1.5

\*LN2 = for ratio 1.25 - 2

\*LN3 = for ratio 3 - 4 - 5 - 6

\*LN = tous rapports

\*LN1 = pour rapports 0.8 - 1 - 1.5

\*LN2 = pour rapports 1.25 - 2

\*LN3 = pour rapports 3 - 4 - 5 - 6

N1, N2 = Level

V, V1, V2, V3 = Drain

R1 = Fill

G, G1 = Grease filler

N1, N2 = Niveaux

V, V1, V2, V3 = Vidange

R1 = Remplissage

G, G1 = Graisseurs





# Z Series - Right angle Spiral Bevel Gearboxes

## Série Z - Renvois d'angle

### FILL, LEVEL & DRAIN POSITION - ZT POSITION DES ORIFICES - ZT

Mounting position K  
Position de fonctionnement K

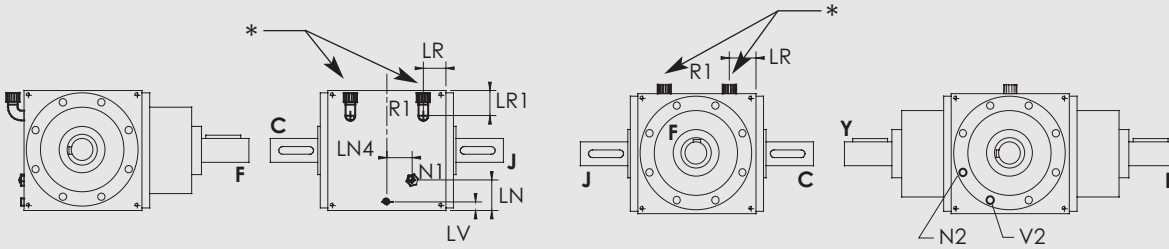

Valid for mounting surfaces R, S, T, U or X  
Valable pour faces de fixation R, S, T, U ou X

Valid for mounting surfaces Z  
Valable pour faces de fixation Z

\*opposite to the pinion / opposé au pignon

Mounting position N or P  
Position de fonctionnement N ou P

Mounting position L or M  
Position de fonctionnement L ou M

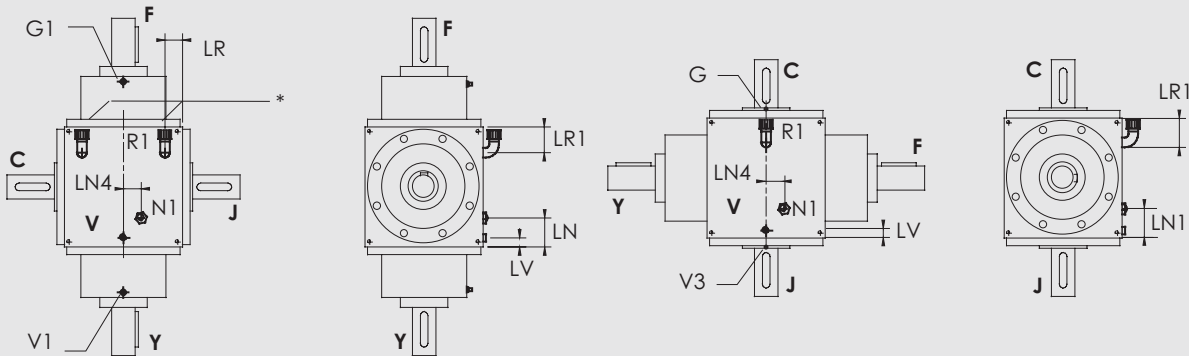

Valid for mounting surfaces R, S, T, U, X or Z  
Valable pour faces de fixation R, S, T, U, X ou Z

Valid for mounting surfaces R, S, T, U, X or Z  
Valable pour faces de fixation R, S, T, U, X ou Z

\*opposite to the pinion / opposé au pignon

Size Taille	ØV	LV	ØV1	ØV2	ØV3	ØN1	LN	LN1	LN4	ØN2	ØR1	LR	LR1	ØG	ØG1
ZT08	1/4"	12	1/8"	M4		1/4"	27	23	15	M4	1/4"	17	35		
ZT10	1/4"	14	1/8"	M5	M6	1/4"	30	30	15	M5	1/4"	17	35	M6	1/8"
ZT12	3/8"	17	1/8"	M6	M6	3/8"	40	35	15	M6	3/8"	22	50	M6	1/8"
ZT16	3/8"	19	1/8"	M8	M6	3/8"	55	45	0	M8	3/8"	27	50	M6	1/8"
ZT20	1/2"	23	1/8"	M8	M6	1/2"	60	58	0	M8	1/2"	50	55	M6	1/8"
ZT25	1/2"	25	1/8"	M10	M6	1/2"	80	75	0	M10	1/2"	60	55	M6	1/8"
ZT31	1/2"	30	1/8"	M12	M6	1/2"	110	110	0	M12	1/2"	90	55	M6	1/8"

N1, N2 = Level  
V, V1, V2, V3 = Drain  
R1 = Fill  
G, G1 = Grease filler

N1/N2 = Niveaux  
V/V1/V2/V3 = Vidange  
R1 = Remplissage  
G/G1 = Graisseurs

All data subject to change without notice  
Données susceptibles d'être modifiées sans préavis

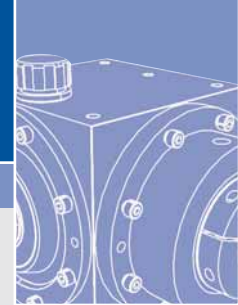

FILL, LEVEL & DRAIN POSITION - ZI & ZD  
POSITION DES ORIFICES - ZI & ZD

Mounting position K  
Position de fonctionnement K

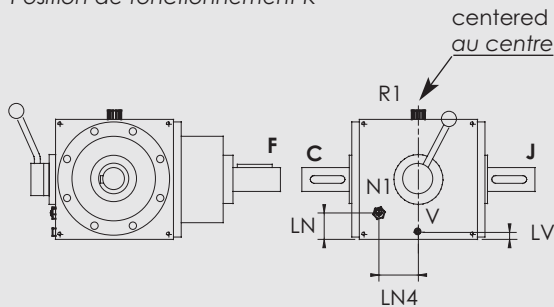

Valid for mounting surfaces R, S, T, U or X  
Valable pour faces de fixation R, S, T, U ou X

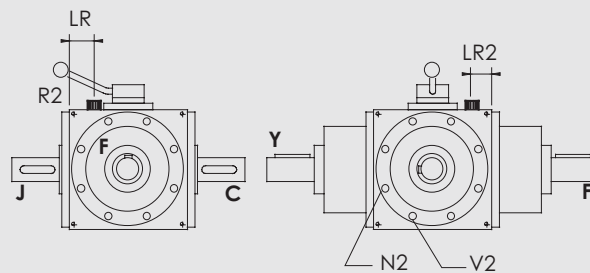

Valid for mounting surfaces Z  
Valable pour faces de fixation Z

Mounting position N or P  
Position de fonctionnement N ou P

Valid for mounting surfaces R, S, T, U, X or Z  
Valable pour faces de fixation R, S, T, U, X ou Z

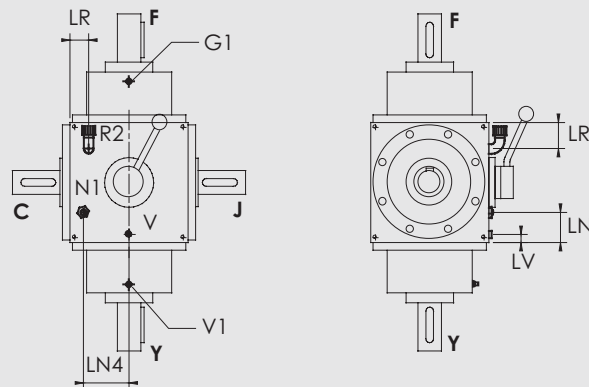

Size Taille	ØV	LV	ØV1	ØV2	ØN1	LN	LN4	ØN2	ØR1	ØR2	LR	LR1	LR2	ØG1
ZI-ZD 10	1/8"	13	1/8"	M5	1/8"	41	37	M5	1/4"	1/8"	17	30	32	1/8"
ZI-ZD 12	1/4"	15,5	1/8"	M6	1/4"	42,5	47	M6	3/8"	1/4"	16	40	40	1/8"
ZI-ZD 16	3/8"	19	1/8"	M8	3/8"	56	50	M8	3/8"	3/8"	27	50	50	1/8"
ZI-ZD 20	1/2"	23	1/8"	M8	1/2"	75	50	M8	1/2"	1/2"	50	55	50	1/8"
ZI-ZD 25	1/2"	25	1/8"	M10	1/2"	90	50	M10	1/2"	1/2"	60	55	55	1/8"
ZI-ZD 31	1/2"	30	1/8"	M12	1/2"	115	50	M12	1/2"	1/2"	90	55	30	1/8"

N1, N2 = Level  
V, V1, V2, V3 = Drain  
R1 = Fill  
G, G1 = Grease filler

N1, N2 = Niveaux  
V, V1, V2, V3 = Vidange  
R1 = Remplissage  
G, G1 = Graisseurs

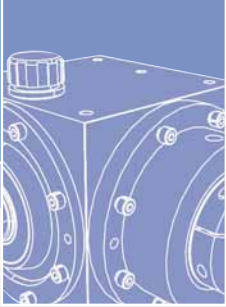

# Z Series - Right angle Spiral Bevel Gearboxes

## Série Z - Renvois d'angle

### SPARE PARTS PIECES DETACHEES

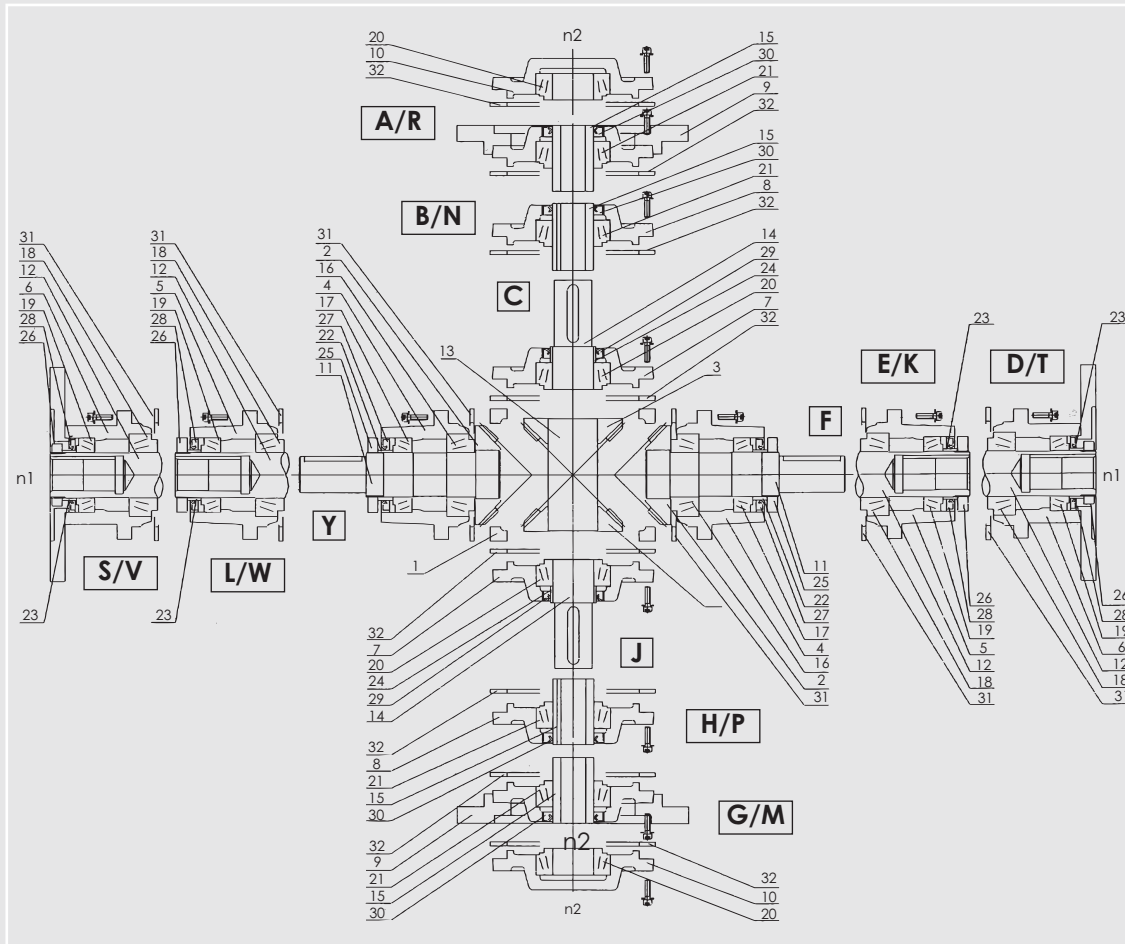

1	Housing	Carter
2	Pinion n1	Pignon n1
3	Bevel gear	Couronne
4	Solid shaft bearing housing	Boîte palière arbre plein
5	Hollow shaft bearing housing	Boîte palière arbre creux
6	Motor flange bearing housing	Boîte palière flasque bride
7	Solid shaft flange	Flasque arbre plein
8	Hollow shaft flange	Flasque arbre creux
9	Motor flange	Flasque bride
10	Solid shaft flange	Flasque arbre plein
11	Solid shaft n1	Arbre n1 plein
12	Hollow shaft n1	Arbre n1 creux
13	Solid through shaft n2	Arbre n2 plein 2 sorties
14	Solid shaft n2	Arbre n2 plein 1 sorties
15	Hollow shaft n2	Arbre n2 creux
16	Ball bearing	Roulement
17	Ball bearing	Roulement

18	Ball bearing	Roulement
19	Ball bearing	Roulement
20	Ball bearing	Roulement
21	Ball bearing	Roulement
22	Ring	Bague de frottement
23	Ring	Bague de frottement
24	Ring	Bague de frottement
25	Nut	Ecrou
26	Nut	Ecrou
27	Oil seal	Joint d'étanchéité
28	Oil seal	Joint d'étanchéité
29	Oil seal	Joint d'étanchéité
30	Oil seal	Joint d'étanchéité
31	Shims	Cale de réglage
32	Shims	Cale de réglage

All data subject to change without notice  
Données susceptibles d'être modifiées sans préavis

