

Semi Automatic Carton Sealer with Automatic Top and Bottom Closure

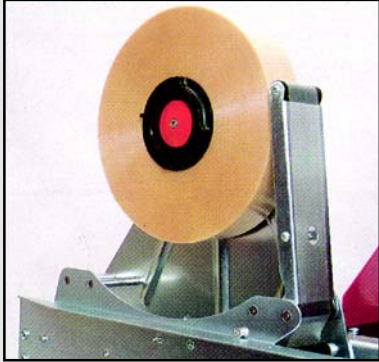

High quality tape dispensers

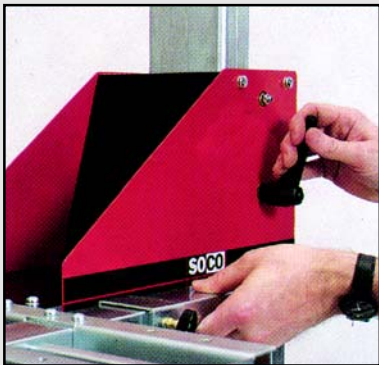

Easy and quick height adjustment

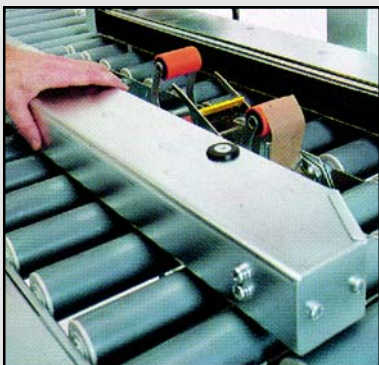

Efficient side drives

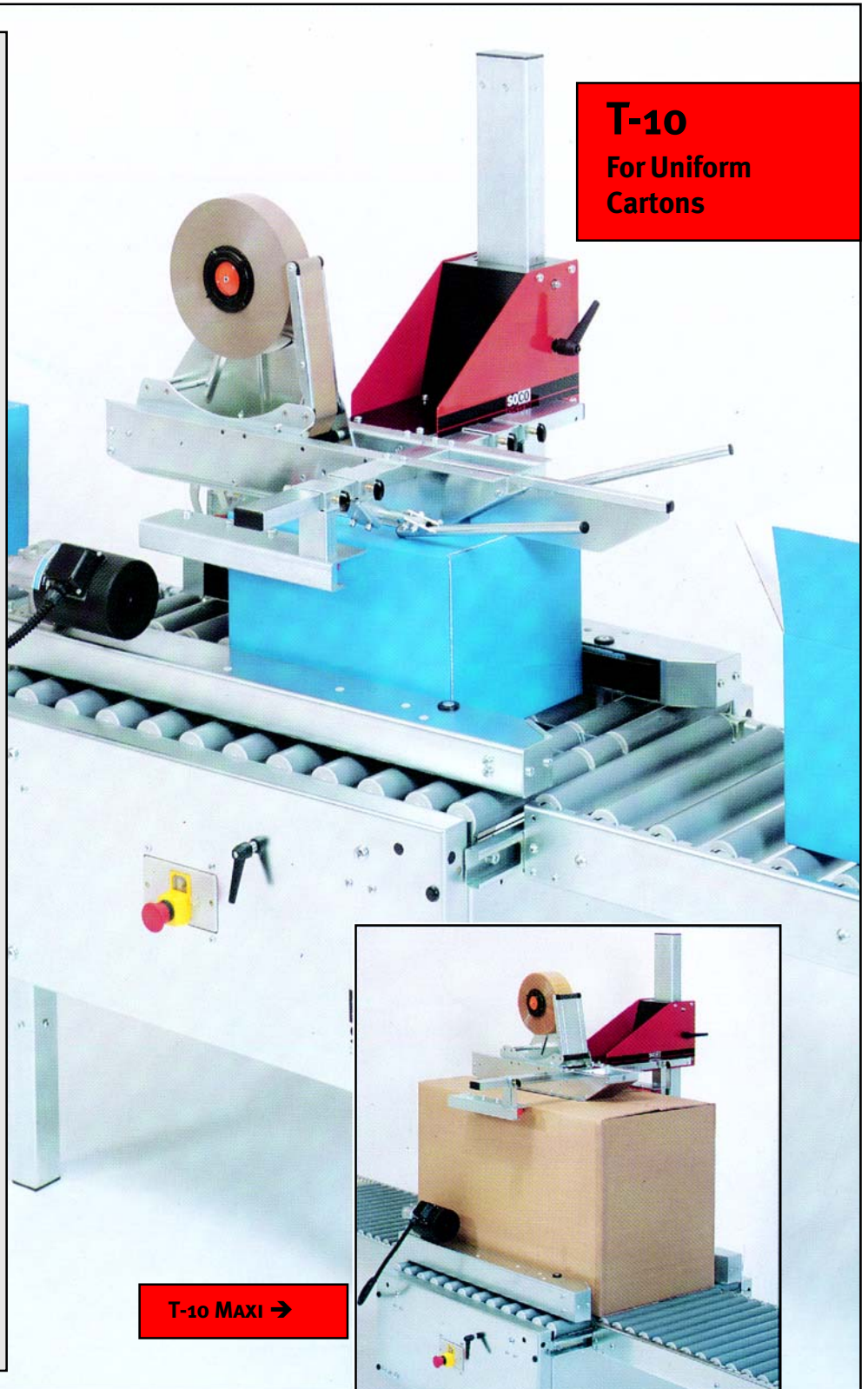

T-10
For Uniform
Cartons

T-10 MAXI →

SOCO
SYSTEM

Purpose-built for “round the clock” applications. Simultaneous top and bottom sealing of uniform carton sizes in batches. Simple and quick adjustment for carton size.

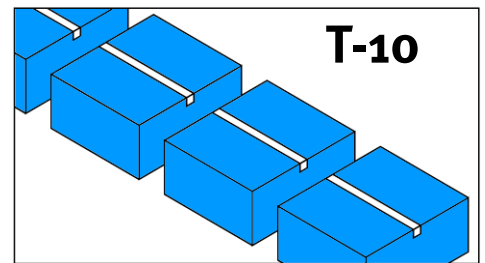

Basic models

The T-10 is available in two standard constructions, the T-10 and the T-10 Maxi. Both models are available with extra high pillars (see table).

The T-10 is available with an electro-zinc or an 18/8 stainless steel finish. In the stainless steel version, all external parts excl. gears, motors and aluminium parts are made of 18/8 stainless steel. The machine is easy to clean and resistant to damp and moisture.

T-10 Maxi

A wide version of the standard T-10. Suitable in industries where large cartons are handled. In its standard version, the T-10 Maxi is fitted with 3 7/8" (100) mm dispenser with 2 5/8" (70 mm) tape overlap.

High Quality Tape Dispensers

The thumbscrew of the tape roller hub makes tape replacement easy and, at the same time, ensures tape roller stability during the sealing process.

Three dispenser types can be used for the T-10 series:

- 1 1/4" (30 mm) dispenser for tape ranging in width from 1 - 1 1/4" (25-30 mm). The tape overlap is 2" (50 mm).
- 2" (50 mm) dispenser for tape ranging in width from 1 1/2 - 2" (38-50 mm). The tape overlap is either 2" (50 mm) or 2 5/8" (70 mm).
- 3 7/8" (100 mm) dispenser for tape ranging in width from 2 1/2 - 3 7/8" (65-100 mm). The tape overlap is 2 5/8" (70 mm).

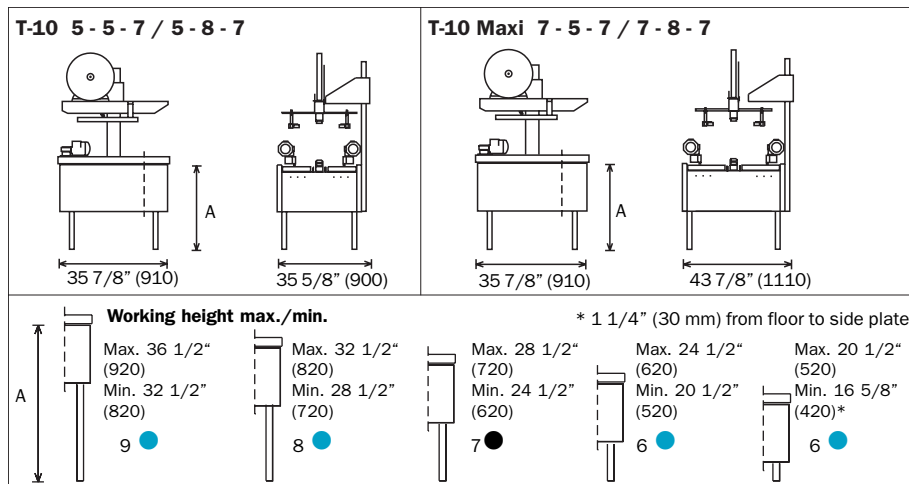

All of SOCO SYSTEM's dispensers are fitted with an adjustable hub brake, adjustable tape roller hub, double roller units, knife guards etc. All the dispensers can be fitted with a monitoring system to supervise the sealing process.

Comprehensive Programme

The T-10 series forms only a small part of a comprehensive selection of carton sealers and conveyor systems. Ask for our main catalogue.

Data	Carton Dimensions*			Tape overlap		Dispenser width			Capacity*	Side drives	Shipping carton dimensions			Weight lbs.	
	Length	Width	Height	2 5/8" (70)	2" (50)	1 1/4" (25-30)	1 1/2" (38-50)	2 1/2" (65-100)			Length	Width	Height		
T-10 5-5-7	Max. 20 1/4" (515) Min. 3 1/2" (90)	20 1/4" (515) 3 1/2" (90)	20 1/2" (520) 3" (75)	●	●	●	●	●	Max. 30/min.	●	●	●	●	51 5/8" (1310) 31 7/8" (810) 35 5/8" (900)	363
T-10 5-8-7	Max. 20 1/4" (515) Min. 3 1/2" (90)	20 1/4" (515) 3 1/2" (90)	32" (815) 3" (75)	●	●	●	●	●	Max. 30/min.	●	●	●	●	51 5/8" (1310) 31 7/8" (810) 35 5/8" (900)	363
T-10 Maxi 7-5-7	Max. 28 5/8" (725) Min. 5 1/2" (140)	28 5/8" (725) 5 1/2" (140)	20 1/2" (520) 6" (155)	●	●	●	●	●	Max. 30/min.	●	●	●	●	51 5/8" (1310) 40 1/4" (1020) 35 5/8" (900)	374
T-10 Maxi 7-8-7	Max. 28 5/8" (725) Min. 5 1/2" (140)	28 5/8" (725) 5 1/2" (140)	32" (815) 6" (155)	●	●	●	●	●	Max. 30/min.	●	●	●	●	51 5/8" (1310) 40 1/4" (1020) 35 5/8" (900)	374
General	3x220/380/420 V 50 Hz. 1x220/110 V 50-60 Hz. Connected load 0.2 kW.			Max. 15 1/4" (385)											

- Standard
- Optional

All measurements are in inches & mm. Right to alter specifications reserved.

SOCO SYSTEM A/S
 Helgeshøj Allé 16 D
 DK-2630 Taastrup
 Tel.: +45 43 52 55 66
 Fax.: +45 43 52 81 16