



9.1 Overview

Low-backlash high-performance precision planetary geared motors

Technical data

i	61 – 121
M_{2acc}	1638 – 7500 Nm
$\Delta\varphi_2$	1 arcmin
η	$\leq 90\%$

Features

Power density	★★★★☆
Backlash	★★★★★
Price category	€€€€
Shaft load	★★★★★
Smooth operation	★★★★★
Torsional stiffness	★★★★☆
Mass moment of inertia	★★★★★
Helical gearing	✓
Maintenance-free	✓
Any installation position	✓
Continuous operation without cooling (FKM seal ring at the input and output)	✓
Pretensioned angular contact bearings at the output in an O-arrangement, ideally suited for helical-gear rack and pinion drives	✓
Compact and highly dynamic due to direct motor attachment	✓

PHVA

Key: ★☆☆☆☆ good | ★★★★★ excellent

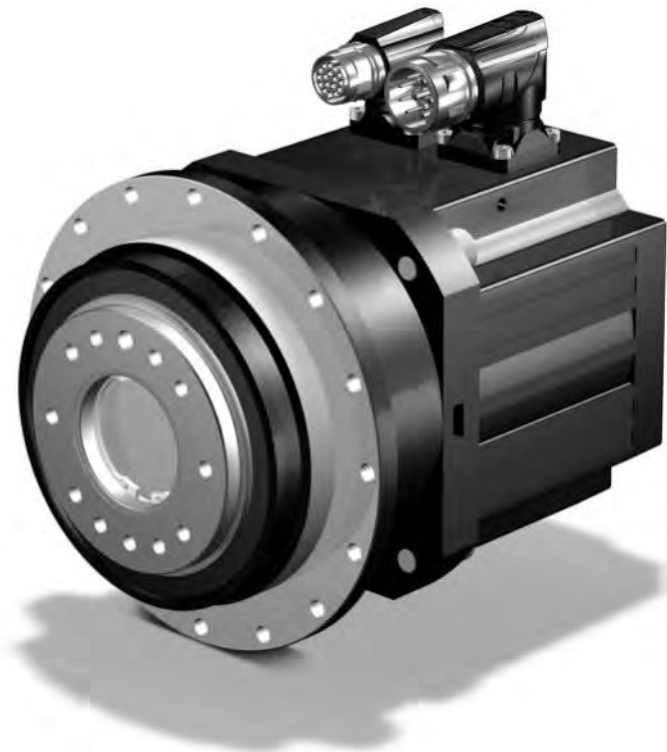



9.2 Selection tables

The technical data specified in the selection tables applies to:

- Installation altitudes up to 1000 m above sea level
- Surrounding temperatures from 0 °C to 40 °C
- Drives with convection-cooled motors (e.g. EZ401U)

You can calculate the technical data for drives with forced ventilated motors (for example EZ401B) at <http://products.stoeber.de>.

Formula symbol	Unit	Explanation
a_{th}	–	Parameter for calculating $K_{mot,th}$
C_2	Nm/ arcmin	Torsional stiffness of gear unit (final stiffness) relative to the gear unit output
$\Delta\varphi_2$	arcmin	Backlash at the output shaft with a blocked input
η	%	Efficiency
i	–	Gear ratio
i_{exakt}	–	Mathematically exact gear ratio
J_1	$10^{-4}kgm^2$	Mass moment of inertia relative to the gear unit input
m	kg	Weight
$M_{2,0}$	Nm	Stall torque on the gear unit output
M_{2acc}	Nm	Maximum permitted acceleration torque on the gear unit output
$M_{2acc,max}$	Nm	Maximum permitted acceleration torque of a group of geared motors whose size and nominal torque n_{1N} are the same
M_{2N}	Nm	Nominal torque on the gear unit output (relative to n_{1N})
M_{2NOT}	Nm	Gear unit emergency-off torque on the gear unit output for max. 1000 load changes
n_{1maxDB}	min^{-1}	Maximum permitted input speed of the gear unit in continuous operation (at surrounding temperature of 20 °C)
n_{1maxZB}	min^{-1}	Maximum permitted input speed of the gear unit in cyclic operation (at surrounding temperature of 20 °C)
n_{1N}	min^{-1}	Nominal speed at the gear unit input
n_{2N}	min^{-1}	Nominal speed at the gear unit output
S	–	Load value: Quotient of gear unit and motor nominal torque without regard to the thermal performance limit. Represents a value for the reserve of the geared motor.



n_{2N}	M_{2N}	$M_{2,0}$	a_{th}	S	Type	M_{2acc}	M_{2NOT}	i	i_{exakt}	n_{1max} DB	n_{1max} ZB	J_1	$\Delta\varphi_2$	C_2	m
[rpm]	[Nm]	[Nm]				[Nm]	[Nm]			[rpm]	[rpm]	[10 ⁻⁴ kgm ²]	[arcmin]	[Nm/ arcmin]	[kg]
PHVA9 ($n_{1N} = 3000$ rpm, $M_{2acc,max} = 4250$ Nm)															
25	806	904	0.2	3.1	PHVA933F1210 EZ701U	2180	9000	121.0	121/1	2500	4500	9.8	1	805	67
25	1307	1568	0.4	1.9	PHVA933F1210 EZ702U	4250	9000	121.0	121/1	2500	4500	15	1	805	70
25	1797	2265	0.5	1.4	PHVA933F1210 EZ703U	4250	9000	121.0	121/1	2500	4500	23	1	805	72
33	606	680	0.3	4.1	PHVA933F0910 EZ701U	1640	9000	91.00	91/1	2500	4500	11	1	838	67
33	983	1179	0.4	2.5	PHVA933F0910 EZ702U	3360	9000	91.00	91/1	2500	4500	16	1	838	70
33	1351	1704	0.6	1.9	PHVA933F0910 EZ703U	4250	9000	91.00	91/1	2500	4500	24	1	838	72
33	1744	2473	0.8	1.4	PHVA933F0910 EZ705U	4250	9000	91.00	91/1	2500	4500	36	1	838	77
33	1826	3038	0.8	1.4	PHVA933F0910 EZ802U	4250	9000	91.00	91/1	2500	4500	60	1	838	86
49	1169	1658	1.0	2.1	PHVA933F0610 EZ705U	4250	9000	61.00	61/1	2500	4500	40	1	850	77
49	1224	2037	1.0	2.0	PHVA933F0610 EZ802U	4250	9000	61.00	61/1	2500	4500	64	1	850	86
49	1460	2646	1.2	1.7	PHVA933F0610 EZ803U	4250	9000	61.00	61/1	2500	4500	89	1	850	92
PHVA9 ($n_{1N} = 4500$ rpm, $M_{2acc,max} = 4250$ Nm)															
37	1318	2178	0.4	1.7	PHVA933F1210 EZ703U	4250	9000	121.0	121/1	2500	4500	23	1	805	72
37	1786	3267	0.6	1.3	PHVA933F1210 EZ705U	4250	9000	121.0	121/1	2500	4500	35	1	805	77
49	860	2826	0.4	2.7	PHVA933F0910 EZ802U	4250	9000	91.00	91/1	2500	4500	60	1	838	86
49	991	1638	0.5	2.3	PHVA933F0910 EZ703U	4250	9000	91.00	91/1	2500	4500	24	1	838	72
49	1343	2457	0.7	1.7	PHVA933F0910 EZ705U	4250	9000	91.00	91/1	2500	4500	36	1	838	77
74	576	1894	0.5	4.0	PHVA933F0610 EZ802U	4250	9000	61.00	61/1	2500	4500	64	1	850	86
74	900	1647	0.8	2.5	PHVA933F0610 EZ705U	4250	9000	61.00	61/1	2500	4500	40	1	850	77
PHVA10 ($n_{1N} = 2000$ rpm, $M_{2acc,max} = 7500$ Nm)															
22	3579	5414	1.1	1.1	PHVA1033F0910 EZ805U	7500	15000	91.00	91/1	2500	4500	137	1	1342	128
33	2399	3629	1.3	1.7	PHVA1033F0610 EZ805U	7500	15000	61.00	61/1	2500	4500	140	1	1370	128
PHVA10 ($n_{1N} = 3000$ rpm, $M_{2acc,max} = 7500$ Nm)															
33	1826	3038	0.6	2.2	PHVA1033F0910 EZ802U	7500	15000	91.00	91/1	2500	4500	62	1	1342	109
33	2179	3948	0.7	1.8	PHVA1033F0910 EZ803U	7500	15000	91.00	91/1	2500	4500	87	1	1342	115
49	1460	2646	0.8	2.7	PHVA1033F0610 EZ803U	7500	15000	61.00	61/1	2500	4500	90	1	1370	115
PHVA10 ($n_{1N} = 4500$ rpm, $M_{2acc,max} = 7500$ Nm)															
49	860	2826	0.3	4.4	PHVA1033F0910 EZ802U	7500	15000	91.00	91/1	2500	4500	62	1	1342	109

PHVA

9.3 Dimensional drawings

In this chapter you can find the dimensions of the geared motors.

There is a dimensional drawing for every possible shaft/housing design, each with the tables for gear unit dimensions, motor dimensions and geared motor dimensions.

Dimensions can exceed the specifications of ISO 2768-mK due to casting tolerances or accumulation of individual tolerances.

We reserve the right to make dimensional changes due to ongoing technical development.

You can download CAD models of our standard drives at <http://cad.stoeber.de>.

Combination options and the dimensions of forced ventilated geared motors can be found at <http://cad.stoeber.de>.



9.3.1 F shaft design (flange shaft)

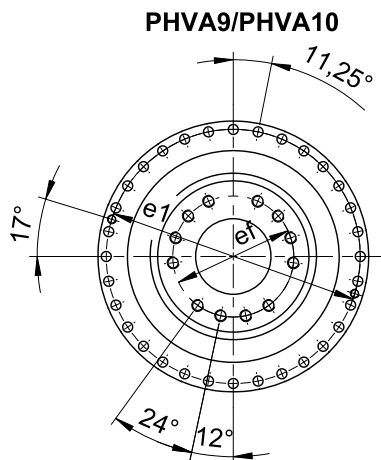
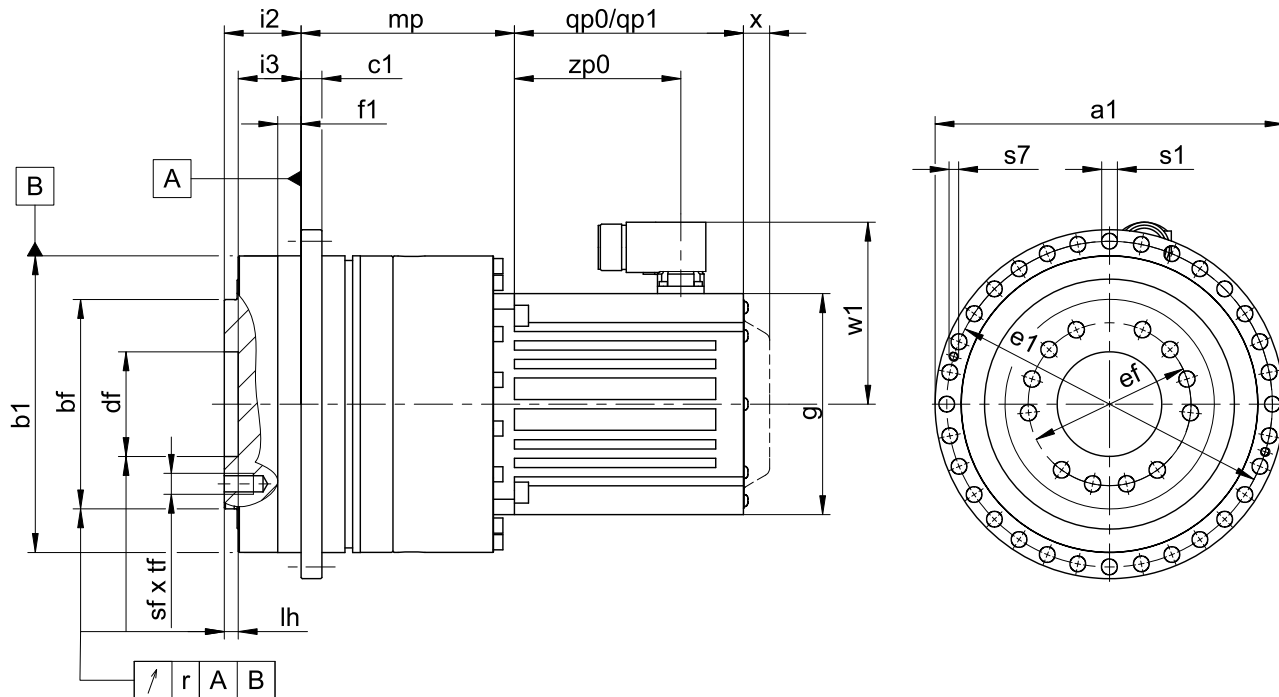

qp0	Applies to motors without brake.	qp1	Applies to motors with brake.
x	Applies to encoders using an optical measuring concept.	w1	For variation for One Cable Solution (OCS), see Chapter 22.4

Dimensions of gear units

Type	$\varnothing a1$	$\varnothing b1$	$\varnothing bf$	c1	$\varnothing df$	$\varnothing e1$	$\varnothing ef$	f1	i2	i3	lh	r	$\varnothing s1$	s7	sf	tf
PHVA933	300	255 _{h7}	180 _{h7}	18	90 ^{H6}	280	140	20	66	55	12	0.030	13.5	M8	M16	24
PHVA1033	330	285 _{h7}	200 _{h7}	20	95 ^{H6}	310	160	20	75	60	10	0.040	13.5	M10	M20	30

Dimensions of motors

Type	$\square g$	qp0	qp1	w1	x	zp0
EZ701U	145	102	161	115.0	22	64
EZ702U	145	127	186	115.0	22	89
EZ703U	145	152	211	115.0	22	114
EZ705U	145	207	266	134.0	22	165
EZ802U	190	197	274	156.5	22	143
EZ803U	190	238	315	156.5	22	184
EZ805U	190	320	397	156.5	22	266



Dimensions of geared motors

Type	EZ7 mp	EZ8 mp
PHVA933	97.0	106.0
PHVA1033	–	108.5

9.4 Type designation

In this chapter, you can find an explanation of the type designation with the associated options. Additional ordering information not included in the type designation can be found at the end of the chapter.

PHVA

Sample code

PHVA	9	3	3	F	0910	EZ703U
------	---	---	---	---	------	--------

Explanation

Code	Designation	Design
PHVA	Type	nLow-backlash planetary gear unit
9	Size	9 (example)
3	Generation	Generation 3
3	Stages	Three-stage
F	Shaft	Flange shaft
0910	Transmission ratio (i x 10)	i = 91 (example)
EZ703U	Motor	EZ synchronous servo motor

In order to complete the type designation, also specify:

- A detailed type designation of the motor, see Chapter [▶ 22](#)
- For reverse operation of the output shaft at $\pm 20^\circ$ to $\pm 90^\circ$ and horizontal installation, note Chapter [▶ 9.6.4](#)

9.5 Product description

9.5.1 Installation conditions

The specified torques and forces only apply when attaching gear units on the machine side using screws of quality 12.9. In addition, the gear housing must be adjusted at pilot $\varnothing b1$ (H7).

9.5.2 Lubricants

STOBER fills the gear units with the amount and type of lubricant specified on the nameplate.

Lubricant filling quantities for gear units, document ID 441871, can be found online at <http://www.stoeber.de>

9.5.3 Other product features

Feature	Value
Max. permitted gear unit temperature (on the surface of the gear unit)	$\leq 90^\circ\text{C}$
Paint	Black RAL 9005



Feature	Value
(ATEX) Directive 2014/34/EU	Not suitable
Protection class: ¹	
Gear unit	IP65
Motor	IP56, optionally IP66

9.5.4 Direction of rotation

The input and output rotate in the same direction.

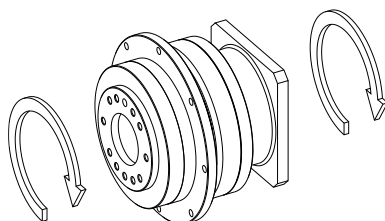

9.6 Project configuration

Project your drive using our SERVOSOFT designing software. You can receive SERVOSOFT for free from your adviser at one of our sales centers. Observe the limit conditions in this chapter to ensure a safe design for your drives.

The formula symbols for values actually present in the application are marked with *.

Formula symbol	Unit	Explanation
a_{th}	–	Parameter for calculating $K_{mot,th}$
ED	%	Duty cycle relative to 20 minutes
fB_{op}	–	Operating mode operating factor
fB_t	–	Run-time operating factor
fB_T	–	Temperature operating factor
F_{2ax}^*	N	Actual axial force at the gear unit output
$F_{2ax,eq}^*$	N	Actual equivalent axial force on the gear unit output
F_{2ax100}	N	Permitted axial force at the gear unit output for $n_{2m} \leq 100$ rpm
F_{2axN}	N	Permitted nominal axial force at the gear unit output
$F_{2rad,acc}$	N	Permitted radial acceleration force at the gear unit output
$F_{2rad,acc}^*$	N	Actual radial acceleration force at the gear unit output
$F_{2rad,acc,1}^*$	N	Actual radial acceleration force at the gear unit output in the first time segment
$F_{2rad,acc,n}^*$	N	Actual radial acceleration force at the gear unit output in the n-th time segment
$F_{2rad,eq}^*$	N	Actual equivalent force at the gear unit output
$F_{2rad100}$	N	Permitted radial force at the gear unit output for $n_{2m} \leq 100$ rpm
F_{2radN}	N	Permitted nominal radial force at the gear unit output
i	–	Gear ratio
$K_{mot,th}$	–	Factor for determining the thermal limit torque
l	mm	Length of the output shaft
L_{10h}	h	Bearing service life

¹ Observe the protection class of all the components.



Formula symbol	Unit	Explanation
M_{op}	Nm	Torque of motor at the operating point from the motor characteristic curve at n_{1m} *
$ M_2 $	Nm	Amount of torque on the output
$M_{2,1^*} - M_{2,6^*}$	Nm	Actual torque in the respective time segment (1 to 6)
M_{2,n^*}	Nm	Actual torque in the n-th time segment
M_{2acc}	Nm	Maximum permitted acceleration torque on the gear unit output
M_{2acc^*}	Nm	Actual acceleration torque on the gear unit output
M_{2eff^*}	Nm	Actual effective torque on the gear unit output
M_{2eq^*}	Nm	Equivalent torque present on the gear unit output
M_{2k100}	Nm	Permitted breakdown torque on the gear unit output for $n_{2m} \leq 100$ rpm
M_{2kN}	Nm	Permitted nominal breakdown torque on the gear unit output
M_{2k^*}	Nm	Actual breakdown torque on the gear unit output
$M_{2k,acc}$	Nm	Permitted acceleration breakdown torque on the gear unit output
M_{2k,acc^*}	Nm	Actual acceleration breakdown torque on the gear unit output
$M_{2k,acc,1^*}$	Nm	Actual acceleration breakdown torque on the gear unit output in the first time segment
M_{2k,acc,n^*}	Nm	Actual acceleration breakdown torque on the gear unit output in the n-th time segment
M_{2k,eq^*}	Nm	Actual equivalent breakdown torque on the gear unit output
M_{2N}	Nm	Nominal torque on the gear unit output (relative to n_{1N})
M_{2NOT}	Nm	Gear unit emergency-off torque on the gear unit output for max. 1000 load changes
M_{2NOT^*}	Nm	Actual emergency off torque for the gear unit on the gear unit output
M_{2th}	Nm	Thermal limit torque on the gear unit output
n_{1m} *	rpm	Actual average input speed
n_{1max} *	rpm	Actual maximum input speed
n_{1maxDB}	min ⁻¹	Maximum permitted input speed of the gear unit in continuous operation
n_{1maxZB}	min ⁻¹	Maximum permitted input speed of the gear unit in cyclic operation
$ n_2 $	rpm	Value of output speed
n_{2m} *	rpm	Actual average output speed
$n_{2m,1^*} - n_{2m,6^*}$	rpm	Actual average output speed in the respective time segment (1 to 6)
n_{2m,n^*}	rpm	Actual average output speed in the n-th time segment
t	s	Time
$t_{1^*} - t_{6^*}$	s	Duration of the respective time segment (1 to 6)
t_{n^*}	s	Duration of the n-th time segment
S	–	Load value: Quotient of gear unit and motor nominal torque without regard to the thermal performance limit. Represents a value for the reserve of the geared motor.
x_2	mm	Distance of the shaft shoulder to the force application point
y_2	mm	Distance of the shaft axis to the axial force application point
z_2	mm	Distance of the shaft shoulder to the middle of the output bearing



9.6.1 Calculation of the operating point

Check the following conditions for operating points other than the nominal point M_{2N} specified in the selection tables.

$$n_{1m^*} \leq \frac{n_{1\max DB}}{fB_T}$$

$$n_{1\max^*} \leq \frac{n_{1\max ZB}}{fB_T}$$

$$M_{2\text{eff}^*} \leq M_{2\text{th}}$$

$$M_{2\text{acc}^*} \leq M_{2\text{acc}}$$

$$M_{2\text{NOT}^*} \leq M_{2\text{NOT}}$$

$$M_{2\text{eq}^*} \leq M_{2N} \cdot \frac{S}{fB_{\text{op}} \cdot fB_t}$$

The values for $n_{1\max DB}$, $n_{1\max ZB}$, $M_{2\text{acc}}$, $M_{2\text{NOT}}$, M_{2N} and S can be found in the selection tables.

The values for fB_T , fB_{op} and fB_t can be found in the corresponding tables in this chapter.

Calculate the thermal limit torque $M_{2\text{th}}$ for a duty cycle $> 50\%$.

Example of cycle sequence

The following calculations are based on a representation of the power taken from the output based in accordance with the following example:

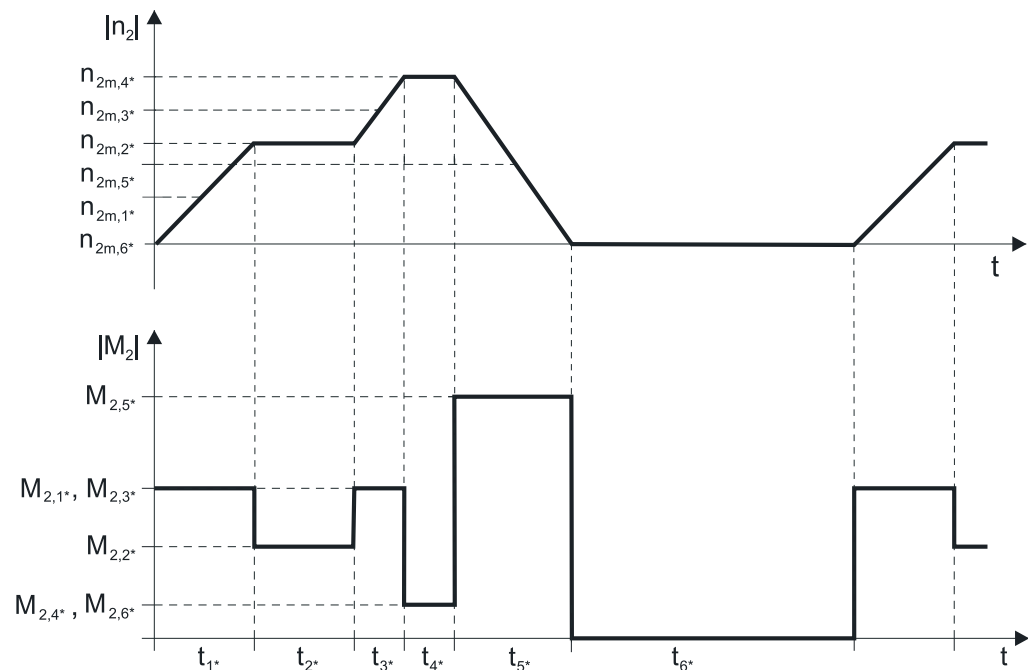

Calculation of the actual average input speed

$$n_{1m^*} = n_{2m^*} \cdot i$$

$$n_{2m^*} = \frac{|n_{2m,1^*}| \cdot t_{1^*} + \dots + |n_{2m,n^*}| \cdot t_{n^*}}{t_{1^*} + \dots + t_{n^*}}$$

If $t_{1^*} + \dots + t_{5^*} \geq 20$ min, calculate n_{2m^*} without the rest phase t_{6^*} .



The values for the ratio i can be found in the selection tables.

Calculation of the actual effective torque

$$M_{2\text{eff}^*} = \sqrt{\frac{t_{1^*} \cdot M_{2,1^*}^2 + \dots + t_{n^*} \cdot M_{2,n^*}^2}{t_{1^*} + \dots + t_{n^*}}}$$

Calculation of the actual equivalent torque

$$M_{2\text{eq}^*} = \sqrt[3]{\frac{|n_{2m,1^*}| \cdot t_{1^*} \cdot |M_{2,1^*}|^3 + \dots + |n_{2m,n^*}| \cdot t_{n^*} \cdot |M_{2,n^*}|^3}{|n_{2m,1^*}| \cdot t_{1^*} + \dots + |n_{2m,n^*}| \cdot t_{n^*}}}$$

Calculation of the thermal limit torque

Calculate the thermal limit torque $M_{2\text{th}}$ for a duty cycle $ED > 50\%$ and the actual average input speed n_{1m^*} . (At $K_{\text{mot,th}} \leq 0$ you must reduce the average input speed n_{1m^*} accordingly or select another geared motor size.)

$$M_{2\text{th}} = M_{\text{op}} \cdot i \cdot K_{\text{mot,th}}$$

$$K_{\text{mot,th}} = 0,93 - \frac{a_{\text{th}}}{1000} \cdot fB_T \cdot \left(\frac{n_{1m^*}}{1000}\right)^3$$

The values for i and a_{th} can be found in the selection tables.

The values for fB_T can be found in the corresponding table in this chapter.

The value for the torque of the motor at operating point M_{op} with the determined average input speed n_{1m^*} can be found in the motor curve of Chapter [22.3]. Note the size, nominal speed n_N and cooling type of the motor. The figure below shows an example of reading the torque M_{op} of a motor with convection cooling at the operating point.

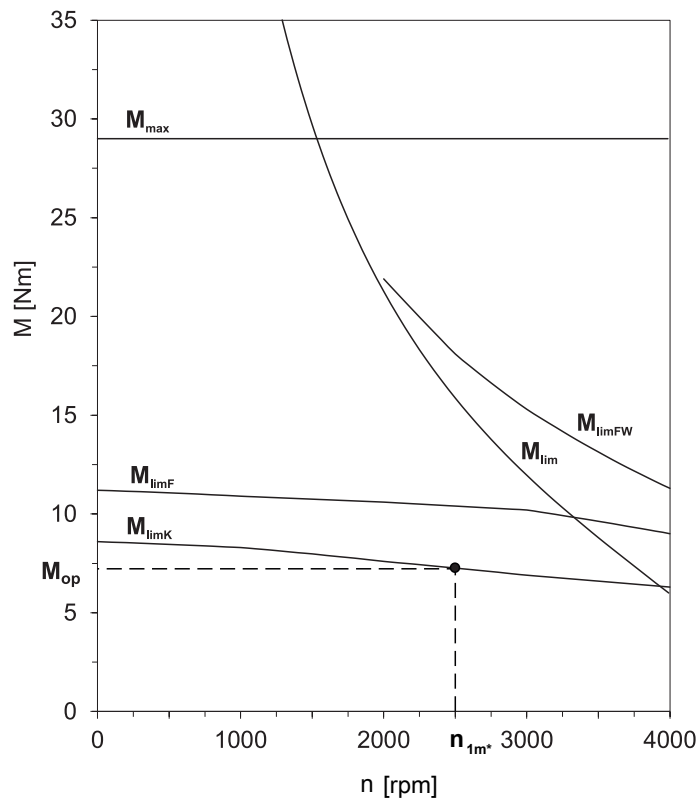



Operating factors

Operating mode		fB_{op}
Uniform continuous operation		1.00
Cyclic operation		1.00
Reversing load cyclic operation		1.00
Run time		fB_t
Daily run time ≤ 8 h		1.00
Daily run time ≤ 16 h		1.15
Daily run time ≤ 24 h		1.20
Temperature		fB_T
Motor cooling	Surrounding temperature	
Motor with forced ventilation	≤ 20 °C	0.9
	≤ 30 °C	1.0
	≤ 40 °C	1.15
Motor with convection cooling	≤ 20 °C	1.0
	≤ 30 °C	1.1
	≤ 40 °C	1.25

Notes

- The maximum permitted gear unit temperature (see the "Other product features" chapter) must not be exceeded. Doing so may result in damage to the geared motor.
- For braking from full speed (for example when the power fails or when setting up the machine), note the permitted gear unit torques (M_{2acc} , M_{2NOT}) in the selection tables.

9.6.2 Permitted shaft loads for the output shaft

The values specified in the tables apply to the permitted shaft loads:

- For shaft dimensions in accordance with the catalog
- For output speeds $n_{2m^*} \leq 100$ rpm ($F_{2axN} = F_{2ax100}$; $F_{2radN} = F_{2rad100}$; $M_{2kN} = M_{2k100}$)
- Only if transverse forces on the gear unit are supported via its pilots (housing, flange shaft)

Permitted shaft loads

Type	z_2 [mm]	F_{2ax100} [N]	$F_{2rad100}$ [N]	$F_{2rad,acc}$ [N]	M_{2k100} [Nm]	$M_{2k,acc}$ [Nm]
PHVA9	155.0	33000	48387	70968	7500	11000
PHVA10	171.0	50000	51462	73099	8800	12500

For other output speeds, download diagrams at <http://products.stoeber.de>.

The following applies to output speeds $n_{2m^*} > 100$ rpm:

$$F_{2axN} = \frac{F_{2ax100}}{\sqrt[3]{\frac{n_{2m^*}}{100 \text{ rpm}}}} \quad F_{2radN} = \frac{F_{2rad100}}{\sqrt[3]{\frac{n_{2m^*}}{100 \text{ rpm}}}} \quad M_{2kN} = \frac{M_{2k100}}{\sqrt[3]{\frac{n_{2m^*}}{100 \text{ rpm}}}}$$

The values for F_{2ax100} , $F_{2rad100}$ and M_{2k100} can be found in the table "Permitted shaft loads" in this chapter.

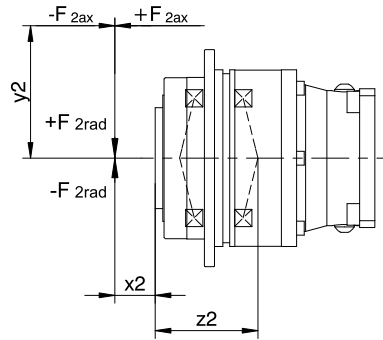

Fig. 1: Force application points

The permitted transverse forces can be determined from the permitted breakdown torque M_{2kN} and $M_{2k,acc}$. The actual transverse forces must not exceed the permitted transverse forces. The permitted transverse forces are based on the end of the hollow shaft ($x_2 = 0$).

$$M_{2k,acc} = \frac{2 \cdot F_{2ax} \cdot y_2 + F_{2rad,acc} \cdot (x_2 + z_2)}{1000} \leq M_{2k,acc}$$

For applications with multiple axial and/or radial forces, you must add the forces as vectors.

In the event of EMERGENCY OFF operation (max. 1000 load changes), you can multiply the permitted forces and torques for F_{2ax100} , $F_{2rad100}$ and M_{2k100} by a factor of two.

Also note the calculation for equivalent values:

$$M_{2k,eq} = \sqrt[3]{\frac{|n_{2m,1}| \cdot t_{1*} \cdot |M_{2k,acc,1}|^3 + \dots + |n_{2m,n}| \cdot t_{n*} \cdot |M_{2k,acc,n}|^3}{|n_{2m,1}| \cdot t_{1*} + \dots + |n_{2m,n}| \cdot t_{n*}}} \leq M_{2kN}$$

$$F_{2rad,eq} = \sqrt[3]{\frac{|n_{2m,1}| \cdot t_{1*} \cdot |F_{2rad,acc,1}|^3 + \dots + |n_{2m,n}| \cdot t_{n*} \cdot |F_{2rad,acc,n}|^3}{|n_{2m,1}| \cdot t_{1*} + \dots + |n_{2m,n}| \cdot t_{n*}}} \leq F_{2radN}$$

$$F_{2ax,eq} \leq F_{2axN}$$

The following apply to the bearing service life L_{10h} (duty cycle $\leq 40\%$):

$$L_{10h} > 10000 \text{ h with } 1 < M_{2kN}/M_{2k*} < 1.25$$

$$L_{10h} > 20000 \text{ h with } 1.25 < M_{2kN}/M_{2k*} < 1.5$$

$$L_{10h} > 30000 \text{ h with } 1.5 < M_{2kN}/M_{2k*}$$

For different duty cycles:

$$L_{10h} > L_{10h(ED=40\%)} \cdot \frac{40\%}{ED}$$

9.6.3 Radial shaft seal rings

Leak-proofness

Our gear units are equipped with high-quality radial shaft seal rings and checked for leak-proofness. However, a leak cannot be fully ruled out over the length of use of the gear unit. If you use the gear unit with goods incompatible with the lubricant, you must take measures to prevent direct contact with the gear unit lubricant in case of a leak.



9.6.4 Reverse operation

To ensure lubrication of circulating geared parts during cyclic reverse operation from $\pm 20^\circ$ to $\pm 90^\circ$, pay careful attention to the position of the output shaft if the gear unit is installed horizontally as shown in the images below.

The images show the center position of reverse operation.

Cyclic reverse operation $\leq \pm 20^\circ$ on request.

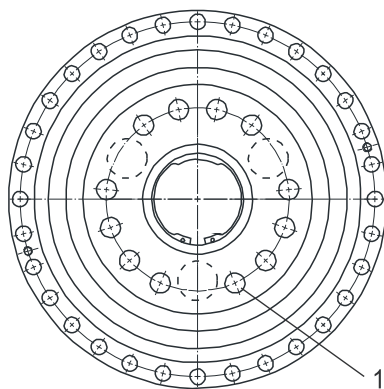

1 Position of the fastening thread: as shown in the image

9.7 Additional documentation

Additional documentation related to the product can be found at <http://www.stoeber.de/en/download>

Enter the ID of the documentation in the Search... field.

Documentation	ID
Operating manual for planetary gear units and motors	441957
Lubricant filling quantities for gear units	441871