



24.1 Overview

Synchronous servo geared motors with hollow shaft

Technical Data

i	3 – 27
M_{2acc}	47 – 500 Nm

Features

Continuous flange hollow shaft for conveying media	✓
Attached compact planetary gear unit with $i = 3, 9$ or 27	✓
Maintenance-free	✓
Any installation position	✓
Continuous operation without cooling (FKM sealing ring on the output)	✓
Backlash-free holding brake (optional)	✓
Convection cooling or water cooling (optional)	✓
Inductive EnDat absolute value encoder	✓
Multiturn absolute value encoders (optional) eliminate the need for referencing	✓
Electronic nameplate for fast and reliable commissioning	✓
Rotating plug connectors with quick lock	✓

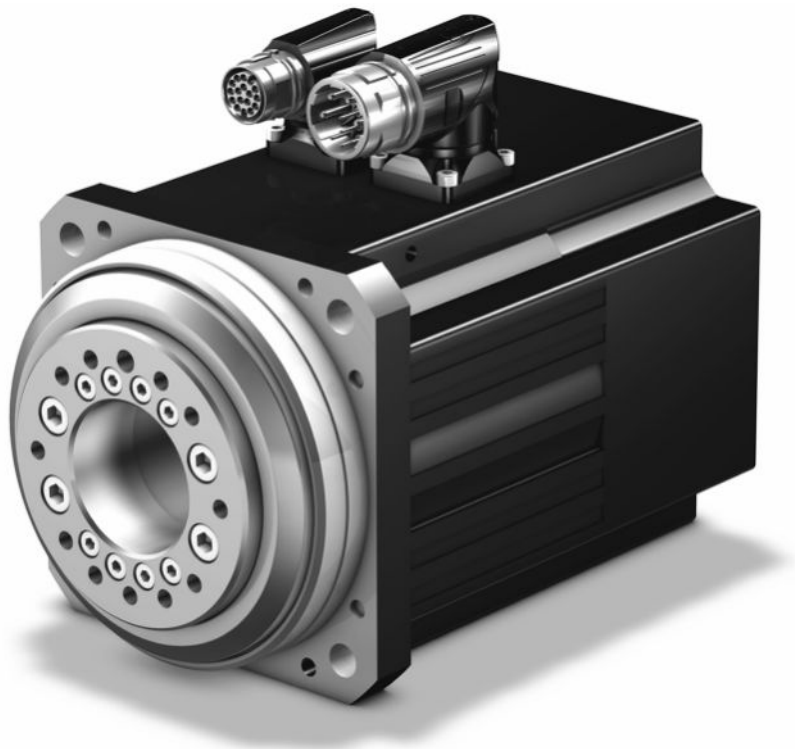

EZHP



24.2 Selection tables

The technical data specified in the selection tables applies for:

- Installation altitudes up to 1000 m above sea level
- Surrounding temperatures from 0° C to 40° C
- Operation on a STÖBER drive controller
- DC link voltage $U_{ZK} = DC 540 V$
- Paint black matte as per RAL 9005

Formula symbols	Unit	Explanation
a_{th}	–	Parameter for calculating $K_{mot,th}$
C_2	Nm/ arcmin	Torsional stiffness of gear unit (final stiffness) relative to the gear unit output
$\Delta\phi_2$	arcmin	Backlash on the output shaft with the input blocked
i	–	Gear ratio
i_{exakt}	–	Mathematically accurate gear transmission ratio
I_0	A	Standstill current: RMS value of the line-to-line current with standstill torque M_0 generated (Tolerance $\pm 5\%$)
I_{max}	A	Maximum current: RMS value of the maximum permitted line-to-line current with maximum torque M_{max} generated (tolerance $\pm 5\%$). Exceeding I_{max} may lead to irreversible damage (demagnetization) of the rotor.
I_N	A	Nominal current: RMS value of the line-to-line current with nominal torque M_N generated (tolerance $\pm 5\%$)
J_1	$10^{-4}kgm^2$	Mass moment of inertia relative to the gear unit input
K_{EM}	V/rpm	Voltage constant: peak value of the induced motor voltage at a speed of 1000 rpm and a winding temperature $\Delta\vartheta = 100 K$ (tolerance $\pm 10\%$)
K_{M0}	Nm/A	Torque constant: ratio of the standstill torque and frictional torque to the standstill current; $K_{M0} = (M_0 + M_R) / I_0$ (tolerance $\pm 10\%$)
$K_{M,N}$	Nm/A	Torque constant: ratio of the nominal torque M_N to the nominal current I_N ; $K_{M,N} = M_N / I_N$ (tolerance $\pm 10\%$)
L_{U-V}	mH	Winding inductance of a motor between two phases (determined in the oscillating circuit)
m	kg	Weight
M_0	Nm	Standstill torque: the torque the motor is able to deliver long term at a speed of 10 rpm (tolerance $\pm 5\%$)
$M_{2,0}$	Nm	Standstill torque on the gear unit output
M_{2acc}	Nm	Maximum permitted acceleration torque on the gear unit output
$M_{2acc,max}$	Nm	Maximum permitted acceleration torque of a group of geared motor having the same size and nominal speed n_{1N}
M_{max}	Nm	Maximum torque: the maximum permitted torque the motor is able to deliver briefly (when accelerating or decelerating) (tolerance $\pm 10\%$)
M_{2N}	Nm	Nominal torque on the gear unit output (relative to n_{1N})
M_{2NOT}	Nm	Emergency off torque of the gear unit at gear unit output for max. 1000 load changes
M_N	Nm	Nominal torque: the maximum torque of a motor in S1 mode at nominal speed n_N (tolerance $\pm 5\%$)



Formula symbols	Unit	Explanation
		You can calculate other torques as follows: $M_{N^*} = K_{M0} \cdot I^* - M_R$.
M_R	Nm	Frictional torque (of the bearings and sealings) of a motor at winding temperature $\Delta\vartheta = 100$ K
n_N	rpm	Nominal speed: the speed for which the nominal torque M_N is specified
n_{1N}	rpm	Nominal speed on the gear unit input
n_{2N}	rpm	Nominal speed on the gear unit output
n_{1maxDB}	rpm	Maximum permitted input speed of the gear unit in continuous operation
n_{1maxZB}	rpm	Maximum permitted input speed of the gear unit in cyclic operation
P_N	kW	Nominal output: the output the motor is able to deliver long term in S1 mode at the nominal point (tolerance ± 5 %)
R_{U-V}	Ω	Winding resistance of a motor between two phases at a winding temperature of 20 °C
S	–	Characteristic load value: quotient of nominal gear unit and motor torque without taking the thermal output limit into consideration. Represents a dimension for the reserve of the geared motor.
T_{el}	ms	Electrical time constant: ratio of the winding inductance to the winding resistance of a motor: $T_{el} = L_{U-V} / R_{U-V}$
U_{ZK}	V	DC link voltage: characteristic value of a drive controller

24.2.1 Technical data for synchronous servo motor

The following tables show the technical data for the motor component of EZHP synchronous servo geared motors. You will need this technical data to calculate the operating point, among other things (see section [▶ 24.7.1](#))

EZHP motors with convection cooling

Type	K_{EM} [V/1000 rpm]	n_N [rpm]	M_N [Nm]	I_N [A]	$K_{M,N}$ [Nm/A]	P_N [kW]	M_0 [Nm]	I_0 [A]	K_{M0} [Nm/A]	M_R [Nm]	M_{max} [Nm]	I_{max} [A]	R_{U-V} [Ω]	L_{U-V} [mH]	T_{el} [ms]
EZHP_511U	97	3000	3.00	3.32	0.90	0.94	4.10	4.06	1.12	0.44	16.0	22.0	3.80	23.50	6.18
EZHP_512U	121	3000	7.00	5.59	1.25	2.2	7.80	6.13	1.34	0.44	31.0	33.0	2.32	16.80	7.24
EZHP_513U	119	3000	8.30	7.04	1.18	2.6	10.9	8.76	1.29	0.44	43.0	41.0	1.25	10.00	8.00
EZHP_515U	141	3000	14.0	9.46	1.48	4.4	16.4	11.0	1.54	0.44	67.0	52.0	0.93	8.33	8.96
EZHP_711U	95	3000	7.30	7.53	0.97	2.3	7.90	7.98	1.07	0.63	20.0	25.0	1.30	12.83	9.87
EZHP_712U	133	3000	11.6	8.18	1.42	3.6	14.4	9.99	1.50	0.63	41.0	36.0	1.00	11.73	11.73
EZHP_713U	122	3000	17.8	13.4	1.33	5.6	20.4	15.1	1.39	0.63	65.0	62.0	0.52	6.80	13.08
EZHP_715U	140	3000	24.6	17.2	1.43	7.7	31.1	21.1	1.50	0.63	104	87.0	0.33	4.80	14.55



EZHP motors with water cooling

Type	K_{EM} [V/1000 rpm]	n_N [rpm]	M_N [Nm]	I_N [A]	$K_{M,N}$ [Nm/A]	P_N [kW]	M_0 [Nm]	I_0 [A]	K_{M0} [Nm/A]	M_R [Nm]	M_{max} [Nm]	I_{max} [A]	R_{U-V} [Ω]	L_{U-V} [mH]	T_{el} [ms]
EZHP_511W	97	3000	4.10	4.50	0.91	1.3	4.80	4.79	1.09	0.44	16.0	22.0	3.80	23.50	6.18
EZHP_512W	121	3000	8.15	6.54	1.25	2.6	9.00	7.07	1.33	0.44	31.0	33.0	2.32	16.80	7.24
EZHP_513W	119	3000	9.70	8.23	1.18	3.1	12.3	9.89	1.29	0.44	43.0	41.0	1.25	10.00	8.00
EZHP_515W	141	3000	16.2	11.0	1.48	5.1	18.6	12.5	1.53	0.44	67.0	52.0	0.93	8.33	8.96
EZHP_711W	95	3000	8.30	8.58	0.97	2.6	9.10	9.18	1.06	0.63	20.0	25.0	1.30	12.83	9.87
EZHP_712W	133	3000	13.6	9.60	1.42	4.3	16.6	11.5	1.50	0.63	41.0	36.0	1.00	11.73	11.73
EZHP_713W	122	3000	20.8	15.7	1.32	6.5	23.7	17.5	1.39	0.63	65.0	62.0	0.52	6.80	13.08
EZHP_715W	140	3000	29.0	20.3	1.43	9.1	35.7	24.2	1.50	0.63	104	87.0	0.33	4.80	14.55

24.2.2 Selection tables for synchronous servo geared motor

See the selection table below for the technical data of EZHP synchronous servo geared motors with convection cooling. For technical data of EZHP synchronous servo geared motors with water cooling go to <http://products.stoeber.de>.

n_{2N} [rpm]	M_{2N} [Nm]	$M_{2,0}$ [Nm]	a_{th}	S	Type	M_{2acc} [Nm]	M_{2NOT} [Nm]	i	i_{exakt}	n_{1max} DB [rpm]	n_{1max} ZB [rpm]	J_1 [10 ⁻⁴ kgm ²]	$\Delta\phi_2$ [arcmin]	C_2 [Nm/ arcmin]	m [kg]
-------------------	------------------	-------------------	----------	---	------	--------------------	--------------------	---	-------------	---------------------------	---------------------------	--	----------------------------	--------------------------	-----------

EZHP_5 ($n_{1N} = 3000rpm, M_{2acc,max} = 200 Nm$)

111	75	103	9.4	1.6	EZHP3511U	200	400	27.00	27/1	3500	4500	13	4	81	12
333	26	35	17	3.2	EZHP2511U	140	400	9.000	9/1	2700	4500	13	4	84	11
333	60	67	40	1.4	EZHP2512U	200	400	9.000	9/1	2700	4500	16	4	84	13
333	71	93	47	1.2	EZHP2513U	200	400	9.000	9/1	2700	4500	19	4	84	15
1000	8.7	12	23	6.6	EZHP1511U	47	400	3.000	3/1	2000	4500	14	3	101	9.2
1000	20	23	53	2.8	EZHP1512U	90	400	3.000	3/1	2000	4500	17	3	101	11
1000	24	32	63	2.4	EZHP1513U	130	400	3.000	3/1	2000	4500	20	3	101	13
1000	41	48	106	1.4	EZHP1515U	190	400	3.000	3/1	2000	4500	26	3	101	16

EZHP_7 ($n_{1N} = 3000rpm, M_{2acc,max} = 500 Nm$)

111	183	198	9.5	1.7	EZHP3711U	500	1000	27.00	27/1	3000	3500	36	4	215	23
111	291	362	15	1.1	EZHP3712U	500	1000	27.00	27/1	3000	3500	45	4	215	25
333	62	68	20	3.4	EZHP2711U	170	1000	9.000	9/1	2000	3500	36	4	217	20
333	99	123	32	2.2	EZHP2712U	350	1000	9.000	9/1	2000	3500	45	4	217	23
333	152	174	50	1.4	EZHP2713U	500	1000	9.000	9/1	2000	3500	54	4	217	26
333	210	266	69	1.0	EZHP2715U	500	1000	9.000	9/1	2000	3500	73	4	217	32
1000	21	23	23	7.0	EZHP1711U	58	1000	3.000	3/1	1600	3500	39	3	259	17
1000	34	42	36	4.4	EZHP1712U	120	1000	3.000	3/1	1600	3500	48	3	259	20
1000	52	59	56	2.9	EZHP1713U	190	1000	3.000	3/1	1600	3500	57	3	259	23
1000	72	91	77	2.1	EZHP1715U	300	1000	3.000	3/1	1600	3500	76	3	259	29



24.3 Torque/speed characteristic curves

Torque/speed characteristic curves depend on the nominal speed and/or winding version of the motor and the DC link voltage of the drive controller that is used. The following torque/speed characteristic curves apply to the DC link voltage DC 540 V.

The following torque/speed characteristic curves apply to EZHP synchronous servo geared motors without gear unit component. The torque/speed characteristic curves of the complete EZHP synchronous servo geared motor can be found at <http://products.stoeber.de>.

Formula symbols	Unit	Explanation
ED	%	Duty cycle relative to 20 minutes
M_{lim}	Nm	Torque limit without compensating for field weakening
M_{limFW}	Nm	Torque limit with compensation for field weakening (applies to operation on STOBER drive controllers only)
M_{limK}	Nm	Torque limit of the motor with convection cooling
M_{limW}	Nm	Torque limit of the motor with water cooling
M_{max}	Nm	Maximum torque: the maximum permitted torque the motor is able to deliver briefly (when accelerating or decelerating) (tolerance $\pm 10\%$)
n_N	rpm	Nominal speed: the speed for which the nominal torque M_N is specified
$\Delta\vartheta$	K	Temperature difference

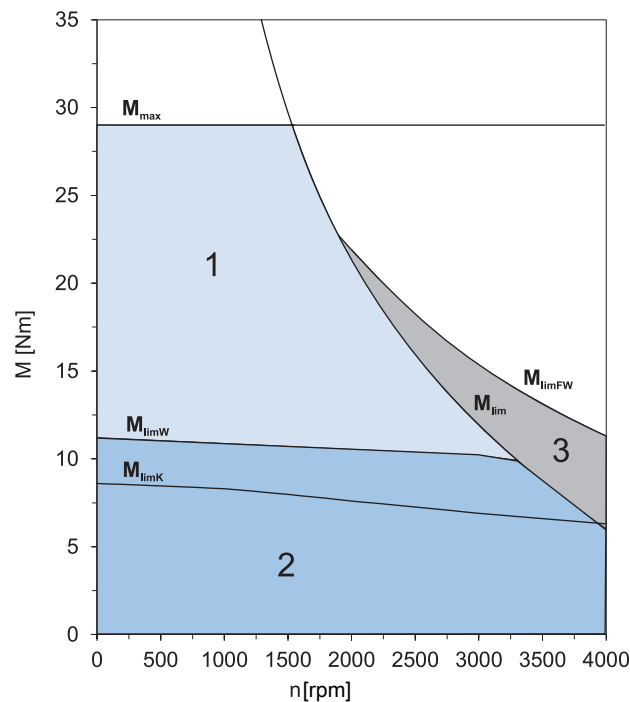
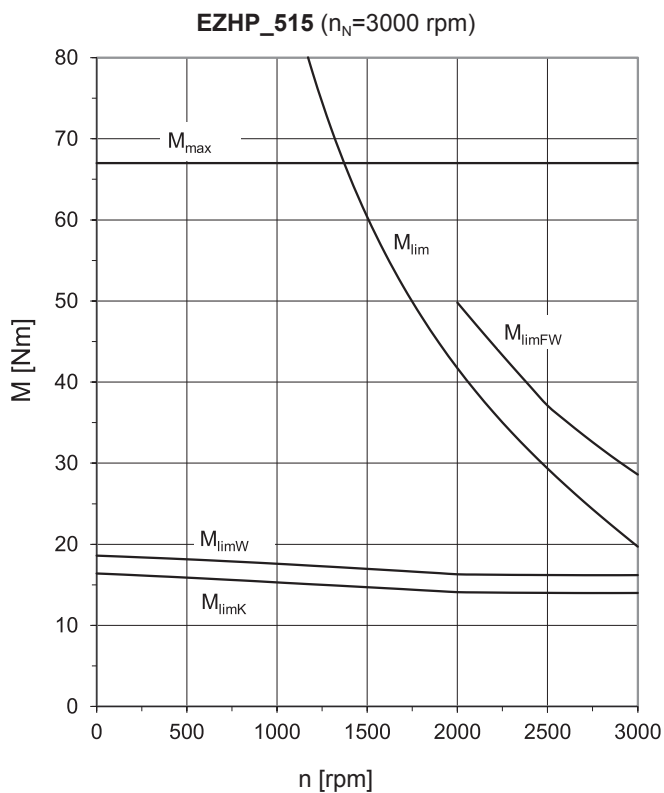
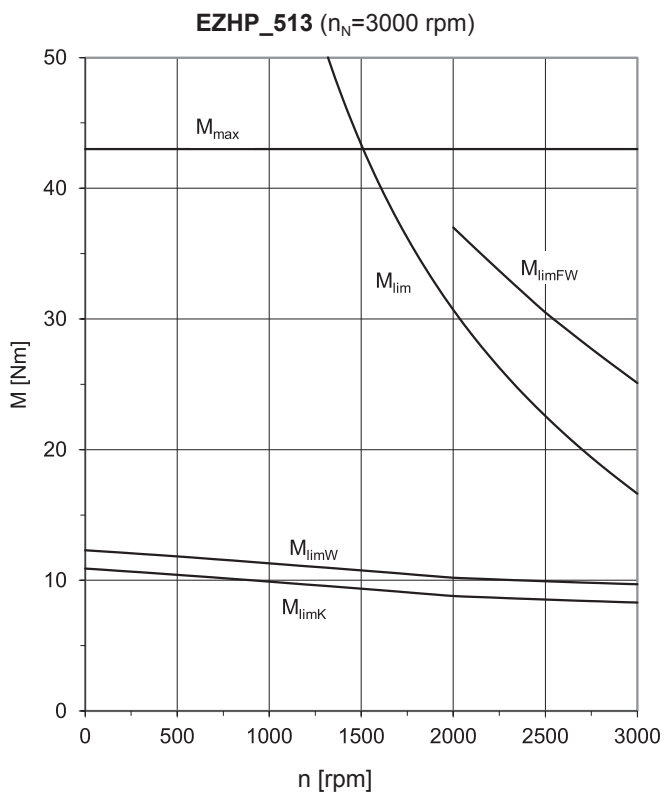
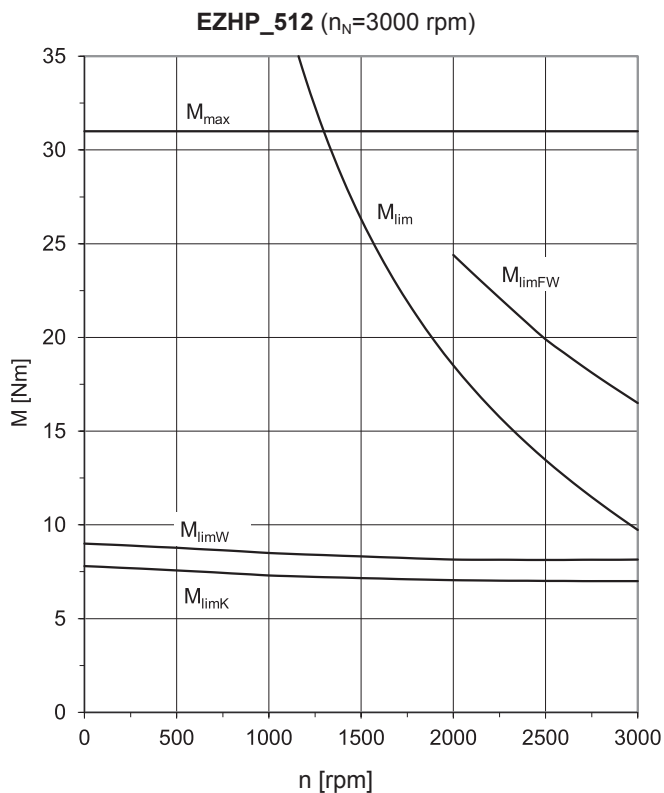
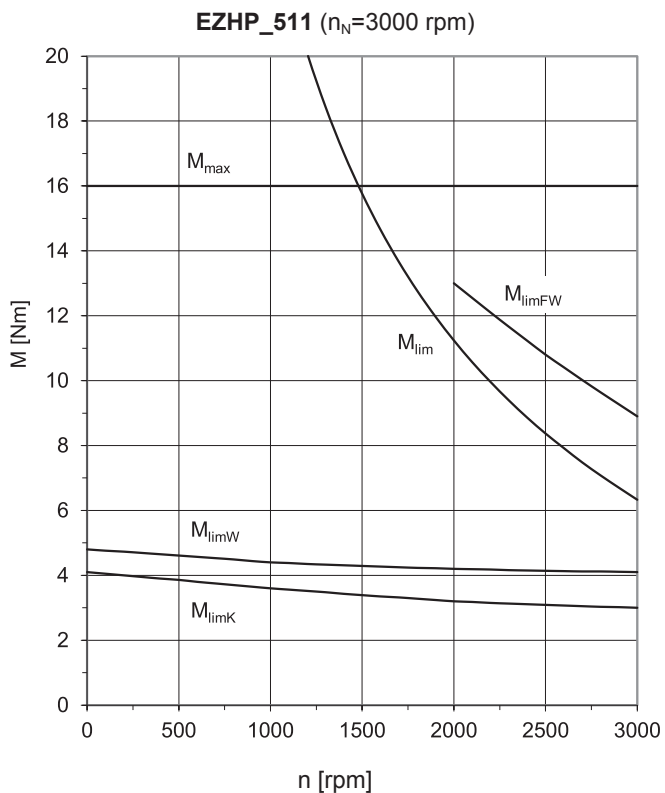
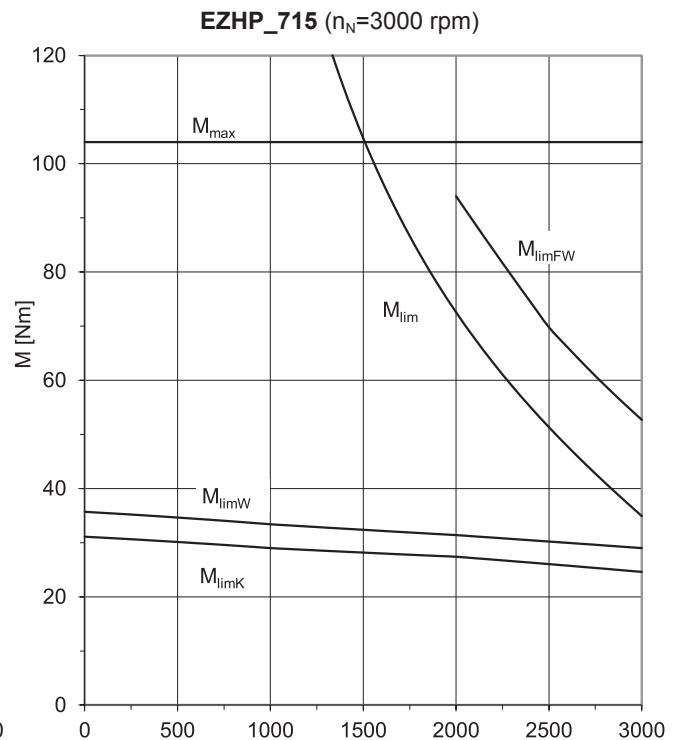
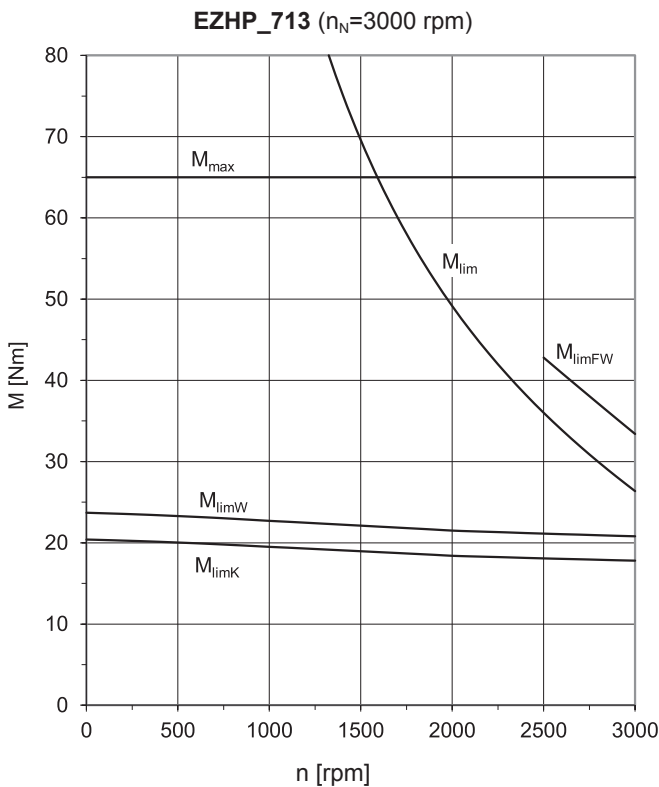
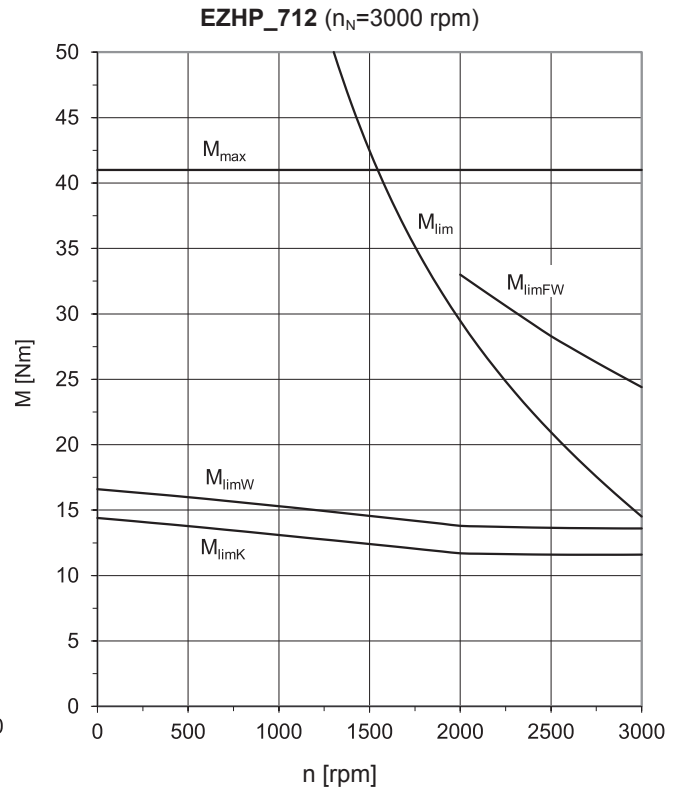
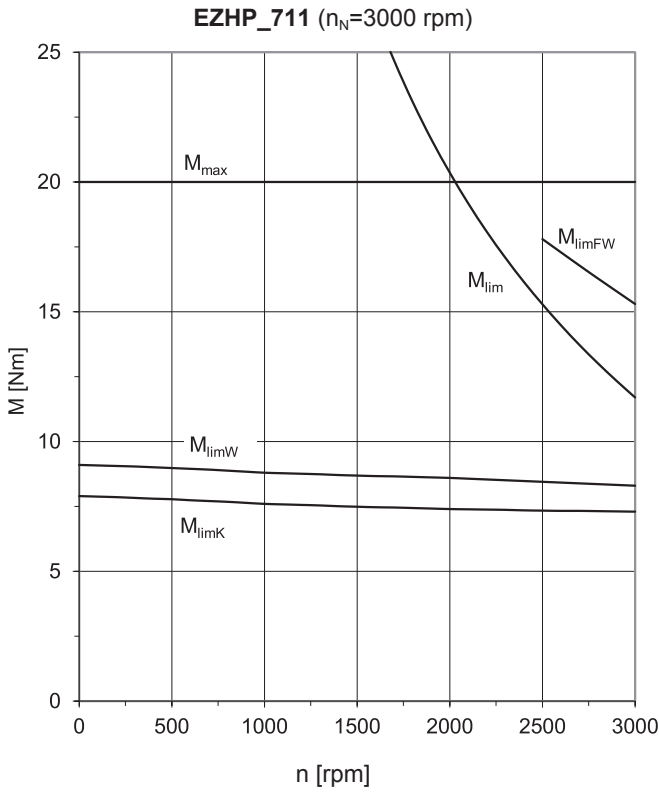

Illustration 1: Explanation of a torque/speed characteristic curve

1	Torque range for brief operation (duty cycle $< 100\%$) with $\vartheta = 100$ K	2	Torque range for continuous operation at a constant load (S1 mode, duty cycle = 100%) with $\vartheta = 100$ K
3	Field weakening range (can only be used with operation on STOBER drive controllers)		





EZHP

24.4 Dimensional drawings

In this chapter you can find the dimensions of the motors.

Dimensions may exceed the requirements of ISO 2768-mK due to casting tolerances or the sum of additional tolerances.



We reserve the right to make modifications to the dimensions due to technical advances.

You can download CAD model of our standard drives from <http://cad.stoerber.de>.

24.4.1 EZHP geared motors with convection cooling

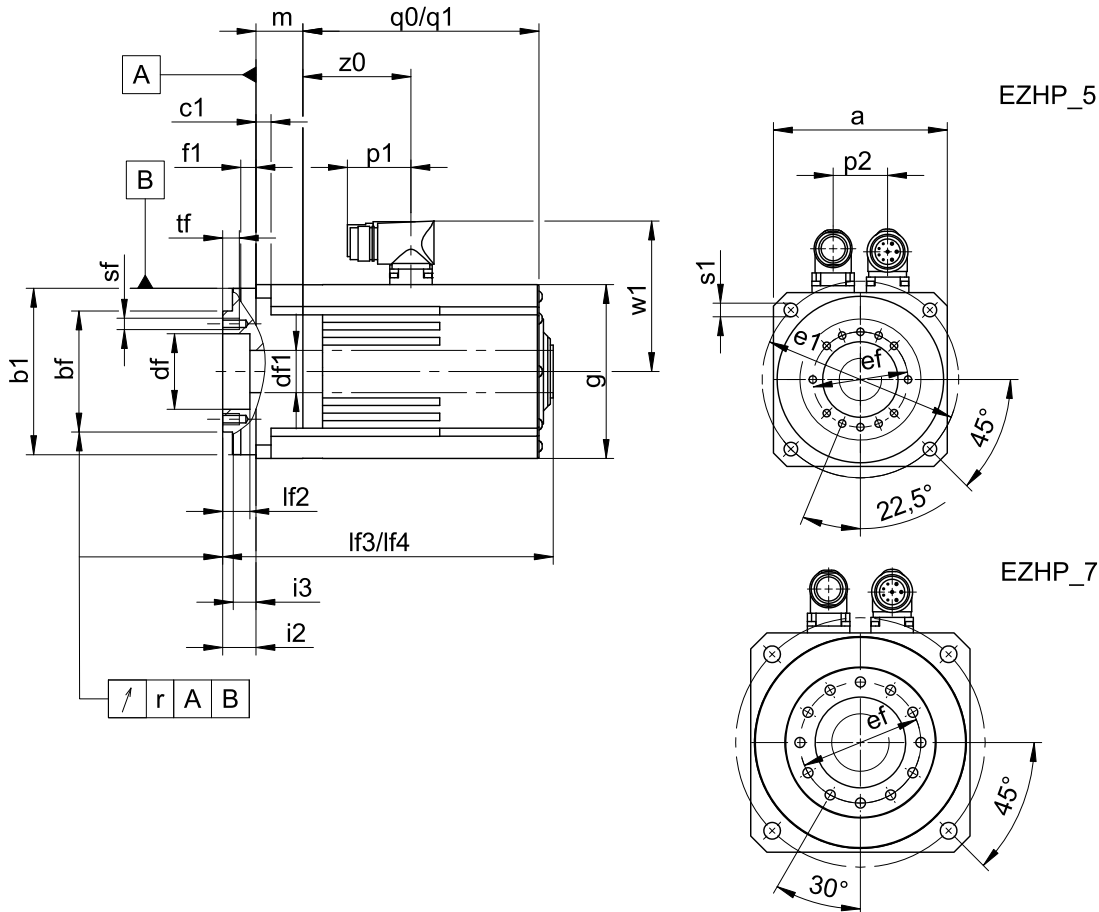

Type	q0, lf3 Applies to motors without holding brake.											q1, lf4 Applies to motors with holding brake.														
	□a	Øb1	Øbf	c1	Ødf	Ødf1	Øe1	Øef	f1	□g	i2	i3	lf2	lf3	lf4	m	p1	p2	q0	q1	r	Øs1	sf	tf	w1	z0
EZHP1511U	115	110 _{H7}	80 _{H7}	10	50 ^{H7}	28	130	63	10	115	29	22.5	18	218.6	273.9	24.0	40	36	156.1	211.4	0.020	9	M6	11	100	71.5
EZHP1512U	115	110 _{H7}	80 _{H7}	10	50 ^{H7}	28	130	63	10	115	29	22.5	18	243.6	298.9	24.0	40	36	181.1	236.4	0.020	9	M6	11	100	96.5
EZHP1513U	115	110 _{H7}	80 _{H7}	10	50 ^{H7}	28	130	63	10	115	29	22.5	18	268.6	323.9	24.0	40	36	206.1	261.4	0.020	9	M6	11	100	121.5
EZHP1515U	115	110 _{H7}	80 _{H7}	10	50 ^{H7}	28	130	63	10	115	29	22.5	18	318.6	373.9	24.0	40	36	256.1	311.4	0.020	9	M6	11	100	171.5
EZHP1711U	145	140 _{H7}	100 _{H7}	15	60 ^{H7}	38	165	80	10	145	38	31.0	20	247.7	307.7	29.5	40	42	170.7	230.7	0.025	11	M8	14	115	77.2
EZHP1712U	145	140 _{H7}	100 _{H7}	15	60 ^{H7}	38	165	80	10	145	38	31.0	20	272.7	332.7	29.5	40	42	195.7	255.7	0.025	11	M8	14	115	102.2
EZHP1713U	145	140 _{H7}	100 _{H7}	15	60 ^{H7}	38	165	80	10	145	38	31.0	20	297.7	357.7	29.5	40	42	220.7	280.7	0.025	11	M8	14	115	127.2
EZHP1715U	145	140 _{H7}	100 _{H7}	15	60 ^{H7}	38	165	80	10	145	38	31.0	20	352.7	412.7	29.5	71	42	275.7	335.7	0.025	11	M8	14	134	178.2
EZHP2511U	115	110 _{H7}	80 _{H7}	10	50 ^{H7}	28	130	63	10	115	29	22.5	18	243.1	298.4	48.5	40	36	156.1	211.4	0.020	9	M6	11	100	71.5
EZHP2512U	115	110 _{H7}	80 _{H7}	10	50 ^{H7}	28	130	63	10	115	29	22.5	18	268.1	323.4	48.5	40	36	181.1	236.4	0.020	9	M6	11	100	96.5
EZHP2513U	115	110 _{H7}	80 _{H7}	10	50 ^{H7}	28	130	63	10	115	29	22.5	18	293.1	348.4	48.5	40	36	206.1	261.4	0.020	9	M6	11	100	121.5
EZHP2711U	145	140 _{H7}	100 _{H7}	15	60 ^{H7}	38	165	80	10	145	38	31.0	20	275.2	335.2	57.0	40	42	170.7	230.7	0.025	11	M8	14	115	77.2
EZHP2712U	145	140 _{H7}	100 _{H7}	15	60 ^{H7}	38	165	80	10	145	38	31.0	20	300.2	360.2	57.0	40	42	195.7	255.7	0.025	11	M8	14	115	102.2
EZHP2713U	145	140 _{H7}	100 _{H7}	15	60 ^{H7}	38	165	80	10	145	38	31.0	20	325.2	385.2	57.0	40	42	220.7	280.7	0.025	11	M8	14	115	127.2
EZHP2715U	145	140 _{H7}	100 _{H7}	15	60 ^{H7}	38	165	80	10	145	38	31.0	20	380.2	440.2	57.0	71	42	275.7	335.7	0.025	11	M8	14	134	178.2
EZHP3511U	115	110 _{H7}	80 _{H7}	10	50 ^{H7}	28	130	63	10	115	29	22.5	18	267.6	322.9	73.0	40	36	156.1	211.4	0.020	9	M6	11	100	71.5
EZHP3711U	145	140 _{H7}	100 _{H7}	15	60 ^{H7}	38	165	80	10	145	38	31.0	20	302.7	362.7	84.5	40	42	170.7	230.7	0.025	11	M8	14	115	77.2
EZHP3712U	145	140 _{H7}	100 _{H7}	15	60 ^{H7}	38	165	80	10	145	38	31.0	20	327.7	387.7	84.5	40	42	195.7	255.7	0.025	11	M8	14	115	102.2



24.4.2 EZHP geared motors with water cooling

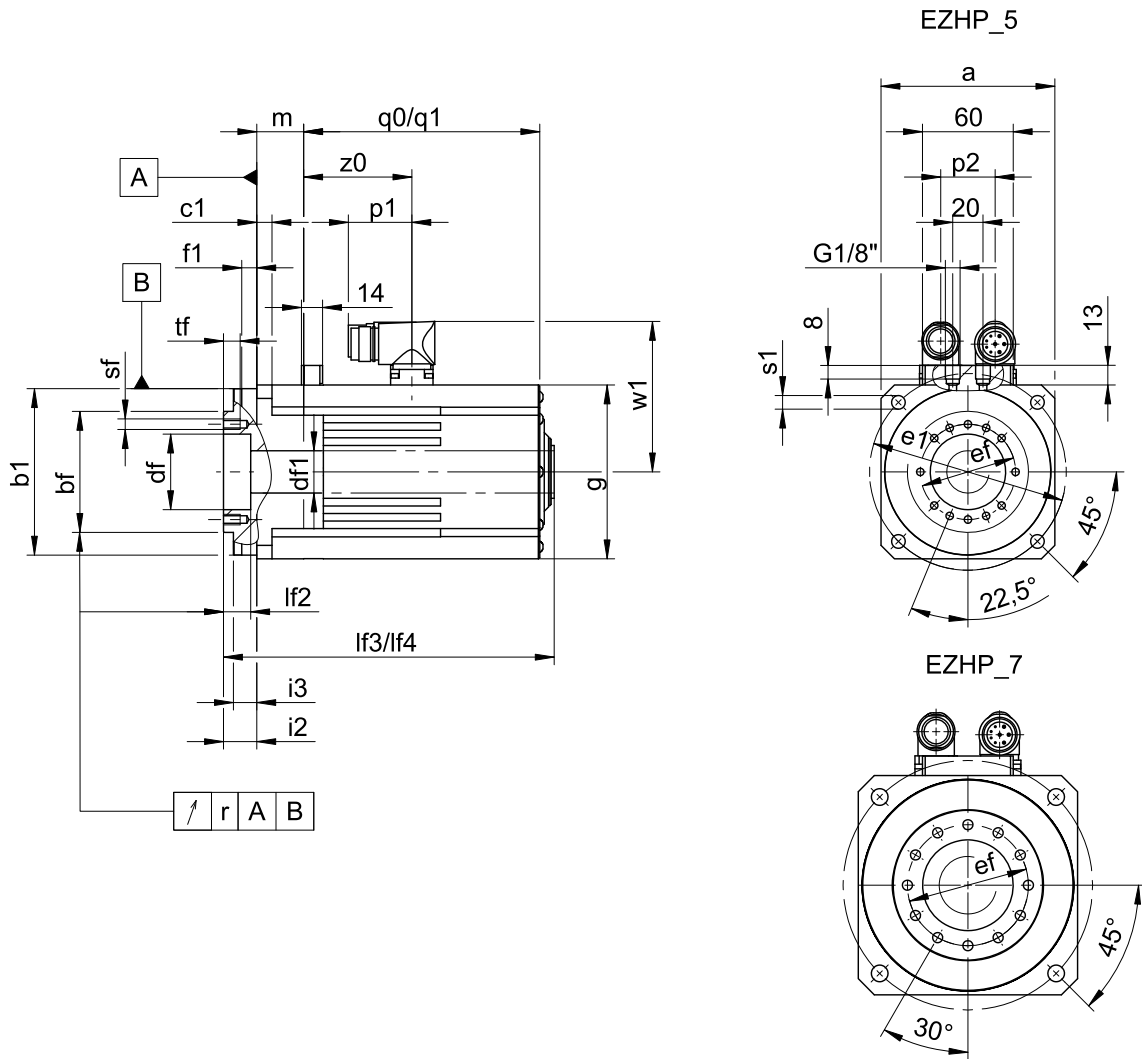

q0, lf3 Applies to motors without holding brake.

q1, lf4 Applies to motors with holding brake.

Type	□a	∅b1	∅bf	c1	∅df	∅df1	∅e1	∅ef	f1	□g	i2	i3	lf2	lf3	lf4	m	p1	p2	q0	q1	r	∅s1	sf	tf	w1	z0
EZHP1511W	115	110 _{h7}	80 _{h7}	10	50 ^{H7}	28	130	63	10	115	29	22.5	18	218.6	273.9	24.0	40	36	156.1	211.4	0.020	9	M6	11	100	71.5
EZHP1512W	115	110 _{h7}	80 _{h7}	10	50 ^{H7}	28	130	63	10	115	29	22.5	18	243.6	298.9	24.0	40	36	181.1	236.4	0.020	9	M6	11	100	96.5
EZHP1513W	115	110 _{h7}	80 _{h7}	10	50 ^{H7}	28	130	63	10	115	29	22.5	18	268.6	323.9	24.0	40	36	206.1	261.4	0.020	9	M6	11	100	121.5
EZHP1515W	115	110 _{h7}	80 _{h7}	10	50 ^{H7}	28	130	63	10	115	29	22.5	18	318.6	373.9	24.0	40	36	256.1	311.4	0.020	9	M6	11	100	171.5
EZHP1711W	145	140 _{h7}	100 _{h7}	15	60 ^{H7}	38	165	80	10	145	38	31.0	20	247.7	307.7	29.5	40	42	170.7	230.7	0.025	11	M8	14	115	77.2
EZHP1712W	145	140 _{h7}	100 _{h7}	15	60 ^{H7}	38	165	80	10	145	38	31.0	20	272.7	332.7	29.5	40	42	195.7	255.7	0.025	11	M8	14	115	102.2
EZHP1713W	145	140 _{h7}	100 _{h7}	15	60 ^{H7}	38	165	80	10	145	38	31.0	20	297.7	357.7	29.5	40	42	220.7	280.7	0.025	11	M8	14	115	127.2
EZHP1715W	145	140 _{h7}	100 _{h7}	15	60 ^{H7}	38	165	80	10	145	38	31.0	20	352.7	412.7	29.5	71	42	275.7	335.7	0.025	11	M8	14	134	178.2
EZHP2511W	115	110 _{h7}	80 _{h7}	10	50 ^{H7}	28	130	63	10	115	29	22.5	18	243.1	298.4	48.5	40	36	156.1	211.4	0.020	9	M6	11	100	71.5
EZHP2512W	115	110 _{h7}	80 _{h7}	10	50 ^{H7}	28	130	63	10	115	29	22.5	18	268.1	323.4	48.5	40	36	181.1	236.4	0.020	9	M6	11	100	96.5
EZHP2513W	115	110 _{h7}	80 _{h7}	10	50 ^{H7}	28	130	63	10	115	29	22.5	18	293.1	348.4	48.5	40	36	206.1	261.4	0.020	9	M6	11	100	121.5
EZHP2711W	145	140 _{h7}	100 _{h7}	15	60 ^{H7}	38	165	80	10	145	38	31.0	20	275.2	335.2	57.0	40	42	170.7	230.7	0.025	11	M8	14	115	77.2
EZHP2712W	145	140 _{h7}	100 _{h7}	15	60 ^{H7}	38	165	80	10	145	38	31.0	20	300.2	360.2	57.0	40	42	195.7	255.7	0.025	11	M8	14	115	102.2
EZHP2713W	145	140 _{h7}	100 _{h7}	15	60 ^{H7}	38	165	80	10	145	38	31.0	20	325.2	385.2	57.0	40	42	220.7	280.7	0.025	11	M8	14	115	127.2
EZHP3511W	115	110 _{h7}	80 _{h7}	10	50 ^{H7}	28	130	63	10	115	29	22.5	18	267.6	322.9	73.0	40	36	156.1	211.4	0.020	9	M6	11	100	71.5
EZHP3711W	145	140 _{h7}	100 _{h7}	15	60 ^{H7}	38	165	80	10	145	38	31.0	20	302.7	362.7	84.5	40	42	170.7	230.7	0.025	11	M8	14	115	77.2

EZHP



24.5 Type designation

Sample code

EZH	P	2	5	1	1	U	F	AD	B1	O	097
-----	---	---	---	---	---	---	---	----	----	---	-----

Explanation

Code	Designation	Design
EZH	Type	Synchronous servo motor with hollow shaft
P	Drive	Attached planetary gear unit
1	Stages	1-stage (i=3)
2		2-stage (i=9)
3		3-stage (i=27)
5	Motor size	5 (example)
1	Generation	1
1	Length	1 (example)
U	Cooling	Convection cooling
W		Water cooling
F	Output	Flange
AD	Drive controller	SD6 (example)
B1	Encoder	EBI 135 EnDat 2.2 (example)
O	Brake	Without holding brake
P		Permanent magnet holding brake
097	Electromagnetic constant (EMC) K_{EM}	97 V/1000 rpm (example)

Instructions

- You can find information about available encoders in section [\[▶ 24.6.7\]](#).
- In section [\[▶ 24.6.7.3\]](#), you can find information about connecting synchronous servo geared motors to other STÖBER drive controllers.
- In section [\[▶ 27\]](#), you can find information about connecting STÖBER synchronous servo motors to drive controllers of third-party manufacturers.

24.6 Product description

24.6.1 General features

Feature	Description
Design	IM B5, IM V1, IM V3 in accordance with EN 60034-7/A1
Protection class	IP56 / IP66 (option)
Thermal class	155 (F) as per EN 60034-1 (155 °C, heating $\Delta\theta = 100$ K)
Maximum permitted temperature at the surface of the geared motor	≤ 80 °C
Surface ¹	Black matte as per RAL 9005
Cooling	IC 410 convection cooling (Water cooling in the A-side flange optional)
Sealing	Gamma ring (on B side), shaft seal ring (on A side)
Shaft	Flange hollow shaft

¹Repainting will change the thermal properties and therefore the performance limits of the motor.



Feature	Description
Vibration intensity	A as per EN 60034-14/A1
Noise level	Limit values according to EN 60034-9/A1 (motor components) Limit values according to VDI 2159 (geared component)

24.6.2 Electrical features

General electrical features of the motor component of the geared motor are described in this section. For details see the selection tables section.

Feature	Description
DC-link-voltage	DC 540 V (max. 620 V) on STÖBER drive controllers
Winding	Three-phase, single-tooth design
Circuit	Star, center not led out
Protection class	I (protective grounding) as per EN 61140/A1
Number of pole pairs	7

24.6.3 Installation conditions

The torques and forces specified only apply for the attachment of gear units on the machine side using screws of quality 10.9. In addition, the gear housing must be adjusted at the pilot (H7).

24.6.4 Lubricants

STÖBER fills the gear units with the amount and type of lubricant specified on the nameplate.

The Quantity of lubricant for gear units, document ID 441871, can be found online at <http://www.stoerber.de>

24.6.5 Direction of rotation

The input and output turn in the same direction.

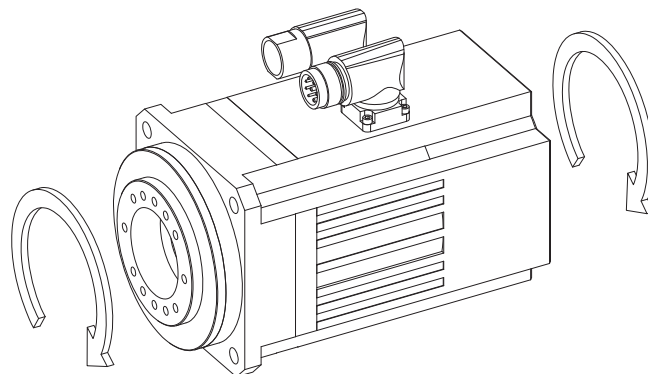

24.6.6 Ambient conditions

Standard ambient conditions for transport, storage and operation of the geared motor are described in this section.



Feature	Description
Transport/storage surrounding temperature ²	-30 °C to +85 °C
Surrounding operating temperature	-15 °C to +40 °C (without water cooling) +10 °C to +40 °C (with water cooling)
Installation altitude	≤ 1000 m above sea level
Shock load	≤ 50 m/s ² (5 g), 6 ms as per EN 60068-2-27

Instructions

- EHYP synchronous servo geared motors are not suitable for use in potentially explosive atmospheres according to ATEX-Richtlinie.
- Brace the motor connection cables close to the motor so that vibrations of the cable do not place unpermitted loads on the motor plug connector.
- Note that the braking torques of the holding brake (optional) may be reduced due to shock loading.
- Also take into consideration the shock load of the geared motor with output units to which the geared motor is connected.

24.6.7 Encoder

STÖBER synchronous servo motors are available in versions with different encoder types. The following sections include information for choosing the optimal encoder for your application.

24.6.7.1 Selection tool for EnDat interface

The following table provides you with a selection tool for the EnDat interface of absolute value encoders.

Feature	EnDat 2.1	EnDat 2.2
Short cycle times	★★☆	★★★
Additional information transferred with the position value	–	✓
Expanded power supply range	★★☆	★★★

Key: ★★☆ = good, ★★★ = very good

24.6.7.2 EnDat encoder

In this chapter you can find detailed technical data of the encoder types that can be selected with EnDat interface.

Encoder with EnDat 2.2 interface

Encoder type	Type code	Measuring principle	Recordable revolutions	Resolution	Position values per revolution
EBI 135	B1	Inductive	65536	19 bits	524288
ECI 119-G2	C9	Inductive	–	19 bits	524288

Encoder with EnDat 2.1 interface

Encoder type	Type code	Measuring principle	Recordable revolutions	Resolution	Position values per revolution	Periods per revolution
ECI 119	C4	Inductive	–	19 bits	524288	Sin/cos 32

² If you will be storing or transporting the system in which a geared motor with water cooling is installed below +3 °C, drain the water completely out of the cooling circuit in advance.



Instructions

- The type code of the encoder is a part of the type designation of the motor.
- Several revolutions of the motor shaft can only be recorded with multiturn encoders.
- The encoder EBI 135 requires an external buffer battery so that the absolute position information will be retained after the power supply is turned off.

24.6.7.3 Possible combinations with drive controllers

The following table shows combination options of STÖBER drive controllers with selectable encoder types.

Drive controller		SDS 5000	MDS 5000	SDS 5000 sin/cos MDS 5000 sin/cos	SD6	SD6 sin/cos
Drive controller type code		AA	AB	AC	AD	AE
ID connection plan		442305	442306	442307	442450	442451
Encoder	Encoder type code					
EBI 135	B1	✓	✓	–	✓	–
ECI 119-G2	C9	✓	✓	–	✓	–
ECI 119	C4	–	–	✓	–	✓

Instructions

- The type code of the drive controller and the encoder are a part of the type designation of the motor (see type designation chapter).
- In section [▶ 27](#), you can find information about connecting STÖBER synchronous servo motors to drive controllers of third-party manufacturers.

24.6.8 Temperature sensor

In this chapter you can find technical data of the temperature sensors that are installed in STÖBER synchronous servo motors for the realization of the thermal winding protection. To prevent damage to the motor, always monitor the temperature sensor with appropriate devices that will turn off the motor if the maximum permitted winding temperature is exceeded.

Some encoders have their own internal analysis electronics with warning and off limits that may overlap with the corresponding values set in the drive controller for the temperature sensor. In some cases this may result in an encoder with internal temperature monitoring forcing the motor to shut down even before the motor has reached its nominal data.

You can find information about the electrical connection of the temperature sensor in the connection technology chapter.

24.6.8.1 PTC thermistor

The PTC thermistor is installed as a standard temperature sensor in STÖBER synchronous servo motors. The PTC thermistor is a drilling thermistor as per DIN 44082, so that the temperature of each winding phase can be monitored.

The resistance values in the following table and characteristic curve refer to a single thermistor as per DIN 44081. These values must be multiplied by 3 for a drilling thermistor in accordance with DIN 44082.

Feature	Description
Nominal response temperature ϑ_{NAT}	145 °C ± 5 K
Resistance R -20 °C up to $\vartheta_{NAT} - 20$ K	≤ 250 Ω
Resistance R with $\vartheta_{NAT} - 5$ K	≤ 550 Ω
Resistance R with $\vartheta_{NAT} + 5$ K	≥ 1330 Ω
Resistance R with $\vartheta_{NAT} + 15$ K	≥ 4000 Ω



Feature	Description
Operating voltage	≤ DC 7,5 V
Thermal response time	< 5 s
Thermal class	155 (F) as per EN 60034-1 (155 °C, heating $\Delta\vartheta = 100$ K)

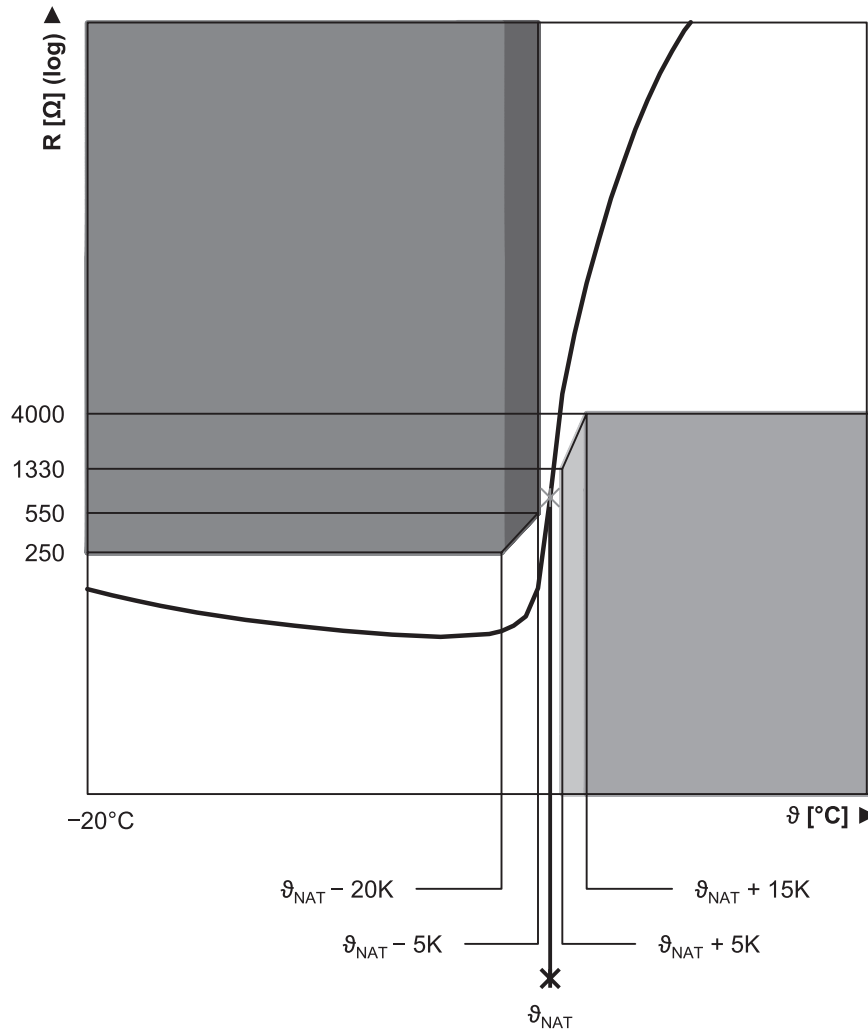

Illustration 2: Characteristic curve of PTC thermistor (single thermistor)

24.6.9 Cooling

An EZHP synchronous servo geared motor in the standard version is cooled by convection cooling (IC 410 in accordance with EN 60034-6). The air flowing around the geared motor is heated by the radiated motor heat and rises. The geared motor can optionally be cooled with water.

24.6.9.1 Water cooling

The EZHP synchronous servo geared motors can optionally be cooled with water to increase the performance data for the same size. Water cooling cannot be retrofitted. It must be specified in the purchase order.

The performance data of the geared motors with water cooling can be found in section [▶ 24.2](#), the dimensional drawings in section [▶ 24.4.2](#).

Cooling circuit specification



Feature	Description
Coolant	Water
Temperature at inlet	+5 °C to +40 °C (max. 5 K below the surrounding temperature)
Cooling circuit	Closed, with recooling unit
Cleanliness	Clear, with no suspended matter or dirt, use particle filter $\leq 100 \mu\text{m}$ if necessary
pH value	6.5 – 7.5
Hardness	1.43 – 2.5 mmol/l
Salinity	NaCl < 100 ppm, demineralized
Anticorrosive	Maximum percentage 25 %, neutral relative to AlCuMgPb F38, GG-220HB
Operating pressure	≤ 3.5 bar (provide a pressure relief valve in the supply line if necessary)
Flow rate	Optimum 6 l/min, minimum 4.5 l/min (EZHP_5) Optimum 7.5 l/min, minimum 5 l/min (EZHP_7)

Instructions

- The nominal data for EZHP synchronous servo geared motors with water cooling refers to water as a coolant. If another coolant is used, the nominal data must be determined again.
- For detailed information about the cooling system or coolants and coolant additives, please contact the manufacturer of your cooling system.
- Coolant with fresh water from the public supply grid with coolants, lubricants or cutting agents from the machining process is not permitted.
- If the temperature of the coolant is lower than the surrounding temperature, interrupt the supply of coolant when the geared motor is stopped for extended times to prevent condensation water from forming.
- If you will be storing or transporting the system in which the geared motor is installed below +3 °C, drain the water completely out of the cooling circuit in advance.
- Further information on water cooling can be found in the operating manual for the geared motor.

24.6.10 Holding brake

STÖBER synchronous servo motors can be equipped with a backlash-free permanent magnet holding brake to keep the motor shaft still when stopped. The holding brake engages automatically if the voltage drops.

Nominal voltage of permanent magnet holding brake: DC 24 V \pm 5 %, smoothed. Take into account the voltage losses in the connection lines of the holding brake.

Observe the following for the configuration:

- The holding brake can be used for braking from full speed (following a power failure or when setting up the machine). Activate other braking processes during operation via corresponding brake functions of the drive controller to prevent premature wear on the holding brake.
- Note that when braking from full speed the braking torque M_{Bdyn} may initially be up to 50 % less. This causes the braking effect to be introduced later and braking distances will be longer.
- Regularly perform a brake test to ensure the functional safety of the brakes. For further details see the documentation of the motor and the drive controller.
- Connect a varistor of type S14 K35 (or comparable) in parallel to the brake coil to protect your machine from switching surges. (Not necessary for connecting the holding brake to STÖBER drive controller with BRS/BRM brake module).



- The holding brake of the synchronous servo motor does not provide adequate safety for person in the hazardous area around gravity-loaded vertical axes. Therefore take additional measures to minimize risk, e.g. by providing a mechanical substructure for maintenance work.
- Take into consideration voltage losses in the connection cables that connect the voltage source to the holding brake connections.
- The braking torque of the brake can be reduced by shock loading. Information about shock loading can be found in the ambient conditions section.

Formula symbols	Unit	Explanation
$I_{N,B}$	A	Nominal current of the brake at 20 °C
ΔJ_B	10^{-4}kgm^2	Additive mass moment of inertia of a motor with holding brake
J	10^{-4}kgm^2	Mass moment of inertia
J_{Bstop}	10^{-4}kgm^2	Reference mass moment of inertia with braking from full speed: $J_{Bstop} = J \times 2$
J_{tot}	10^{-4}kgm^2	Total mass moment of inertia (relative to the motor shaft)
Δm_B	kg	Additive weight of a motor with holding brake
M_{Bdyn}	Nm	Dynamic braking torque at 100 °C (Tolerance +40 %, -20 %)
M_{Bstat}	Nm	Static braking torque at 100 °C (Tolerance +40 %, -20 %)
M_L	Nm	Load torque
N_{Bstop}	–	Permitted number of braking processes from full speed ($n = 3000$ rpm) with J_{Bstop} ($M_L = 0$). The following applies if the values of n and J_{Bstop} differ: $N_{Bstop} = W_{B,Rlim} / W_{B,R/B}$.
n	rpm	Speed
t_1	ms	Linking time: time from when the current is turned off until the nominal braking torque is reached
t_2	ms	Disengagement time: time from when the current is turned on until the torque begins to drop
t_{11}	ms	Response delay: time from when the current is turned off until the torque increases
t_{dec}	ms	Stop time
$U_{N,B}$	V	Nominal voltage of brake (DC 24 V ± 5 % (smoothed))
$W_{B,R/B}$	J	Friction work per braking
$W_{B,Rlim}$	J	Friction work until wear limit is reached
$W_{B,Rmax/h}$	J	Maximum permitted friction work per hour per individual braking
$x_{B,N}$	mm	Nominal air gap of brake

Calculation of friction work per braking process

$$W_{B,R/B} = \frac{J_{tot} \cdot n^2}{182.4} \cdot \frac{M_{Bdyn}}{M_{Bdyn} \pm M_L}$$

The sign of M_L is positive if the movement runs vertically up or horizontally and negative if the movement runs vertically down.

Calculation of the stop time

$$t_{dec} = 2.66 \cdot t_1 + \frac{n \cdot J_{tot}}{9.55 \cdot M_{Bdyn}}$$



Switching characteristics

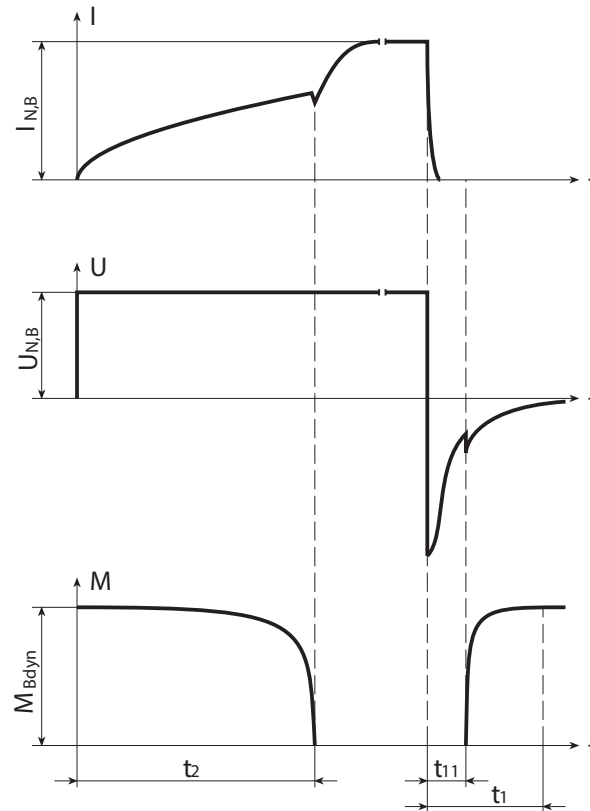

Technical Data

	M_{Bstat} [Nm]	M_{Bdyn} [Nm]	$I_{N,B}$ [A]	$W_{B,Rmax/h}$ [kJ]	$N_{B,stop}$	$J_{B,stop}$ [$10^{-4}kgm^2$]	$W_{B,Rlim}$ [kJ]	t_2 [ms]	t_{11} [ms]	t_1 [ms]	$x_{B,N}$ [mm]	ΔJ_B [$10^{-4}kgm^2$]	Δm_B [kg]
EZHP_511	18	15	1.1	11.0	3250	34.1	550	55	3.0	30	0.3	5.450	2.32
EZHP_512	18	15	1.1	11.0	2750	40.2	550	55	3.0	30	0.3	5.450	2.32
EZHP_513	18	15	1.1	11.0	2400	46.3	550	55	3.0	30	0.3	5.450	2.32
EZHP_515	18	15	1.1	11.0	1850	58.8	550	55	3.0	30	0.3	5.450	2.32
EZHP_711	28	25	1.1	25.0	3200	88.6	1400	120	4.0	40	0.4	12.620	3.91
EZHP_712	28	25	1.1	25.0	2650	107	1400	120	4.0	40	0.4	12.620	3.91
EZHP_713	28	25	1.1	25.0	2250	125	1400	120	4.0	40	0.4	12.620	3.91
EZHP_715	28	25	1.1	25.0	1700	162	1400	120	4.0	40	0.4	12.620	3.91

24.6.11 Connection method

The following sections describe the connection technology of STÖBER synchronous servo motors in the standard version of STÖBER drive controllers. You can find further information relating to the drive controller type that was specified in your order in the connection plan that is delivered with every synchronous servo motor.

In section [▶ 27](#), you can find information about connecting STÖBER synchronous servo motors to drive controllers of third-party manufacturers.

EZHP

24.6.11.1 Plug connector

STÖBER synchronous servo motors are equipped with twistable quick lock plug connectors in the standard version. For details see this section.

In motors with water cooling, prevent collisions between the motor connection cables and the connecting lines of the cooling system. In the event of a collision, turn the motor plug connectors appropriately. Details regarding the position of the connections for water cooling can be found in the dimensional drawings section.

The illustrations represent the position of the plug connectors when delivered.



Turning ranges of plug connectors

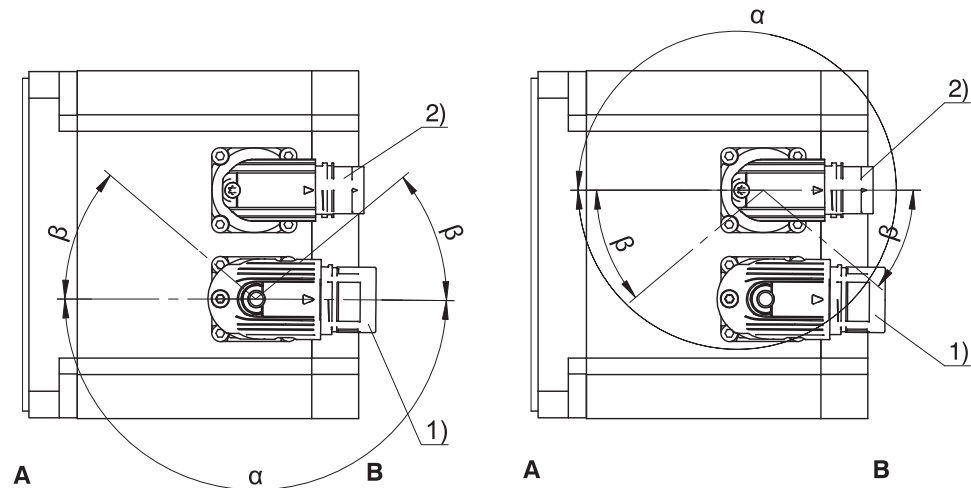

1	Power plug connector	2	Encoder plug connector
A	Attachment or output side of the motor	B	Rear of the motor

Power plug connector features

Motor type	Size	Connection	Turning range	
			α	β
EZHP_5, EZHP_711 – EZHP_713	con.23	Quick lock	180°	40°
EZHP_715	con.40	Quick lock	180°	40°

Encoder plug connector features

Motor type	Size	Connection	Turning range	
			α	β
EZHP	con.17	Quick lock	180°	20°

Instructions

- The number after "con." indicates approximately the external thread diameter of the plug connector in mm (for example con.23 designates a plug connector with an external thread diameter of about 23 mm).
- In turning range β the power and encoder plug connectors can only be turned if they will not collide with each other by doing so.

24.6.11.2 Connection of the motor housing to the protective ground system

Connect the motor housing to the protective ground system to protect persons and to prevent the false triggering of fault current protection devices.

All attachment parts required for the connection of the protective ground to the motor housing are delivered with the motor. The grounding screw of the motor is identified with the symbol  as per IEC 60417-DB. The minimum cross-section of the protective ground is specified in the following table.

Cross-section of the copper protective grounding in the power cable (A)	Cross-section of the copper protective ground for motor housing (A_E)
$A < 10 \text{ mm}^2$	$A_E = A$
$A \geq 10 \text{ mm}^2$	$A_E \geq 10 \text{ mm}^2$



24.6.11.3 Connection assignment of the power plug connector

The size and connection plan of the power plug connector depend on the size of the motor. The colors of the connection strands inside the motor and specified according to IEC 60757.

Plug connector size con.23 (1)

Connection diagram	Pin	Connection	Color
	1	1U1 (phase U)	BK
	3	1V1 (phase V)	BU
	4	1W1 (phase W)	RD
	A	1BD1 (brake +)	RD
	B	1BD2 (brake -)	BK
	C	1TP1/1K1 (temperature sensor)	
	D	1TP2/1K2 (temperature sensor)	
		PE (protective ground)	GNYE

Plug connector size con.40 (1.5)

Connection diagram	Pin	Connection	Color
	U	1U1 (phase U)	BK
	V	1V1 (phase V)	BU
	W	1W1 (phase W)	RD
	+	1BD1 (brake +)	RD
	-	1BD2 (brake -)	BK
	1	1TP1/1K1 (temperature sensor)	
	2	1TP2/1K2 (temperature sensor)	
		PE (protective ground)	GNYE

24.6.11.4 Connection assignment of encoder plug connector

The size and connection assignment of the encoder plug connector depend on the type of the installed encoder and the size of the motor. The colors of the connection strands inside the motor and specified according to IEC 60757.



Encoder EnDat 2.1/2.2 digital, plug connector size con.17

Connection diagram	Pin	Connection	Color
	1	Clock +	VT
	2	Up sense	BN GN
	3		
	4		
	5	Data -	PK
	6	Data +	GY
	7		
	8	Clock -	YE
	9		
	10	0 V GND	WH GN
	11		
	12	Up +	BN GN
Pin 2 is connected with pin 12 in the built-in socket			

Encoder EnDat 2.2 digital with battery buffering, plug connector size con.17

Connection diagram	Pin	Connection	Color
	1	Clock +	VT
	2	UBatt +	BU
	3	UBatt -	WH
	4		
	5	Data -	PK
	6	Data +	GY
	7		
	8	Clock -	YE
	9		
	10	0 V GND	WH GN
	11		
	12	Up +	BN GN
UBatt+ = DC 3.6 V for encoder type EBI in combination with the AES option of STOBER-drive controllers			



Encoder EnDat 2.1 with sin/cos incremental signals, plug connector size con.17

Connection diagram	Pin	Connection	Color
	1	Up sense	BU
	2		
	3		
	4	0 V sense	WH
	5		
	6		
	7	Up +	BN GN
	8	Clock +	VT
	9	Clock -	YE
	10	0 V GND	WH GN
	11		
	12	B + (sin +)	BU BK
	13	B - (sin -)	RD BK
	14	Data +	GY
	15	A + (cos +)	GN BK
	16	A - (cos -)	YE BK
	17	Data -	PK

24.7 Projecting

You can project your drives with our SERVOfsoft design software. SERVOfsoft is available at no cost from your consultant in one of our sales centers. Note the limit conditions in this section for a safe design of your drives.

24.7.1 Calculation of the operating point

In this chapter you can find information that is necessary for the calculation of the operating point.

The formula symbols for values actually present in the application are identified by a *.

Formula symbols	Unit	Explanation
a_{th}	–	Parameter for calculating $K_{mot,th}$
ED	%	Duty cycle relative to 20 minutes
fB_{op}	–	Operational factor – operation mode
fB_t	–	Operational factor – runtime
fB_T	–	Operational factor – temperature
i	–	Gear ratio
$K_{mot,th}$	–	Factor for determining the thermal limit torque
$ M_2 $	Nm	Amount of the torque on the output
$M_{2.1^*} - M_{2.6^*}$	Nm	Existing torque in the relevant time segment (1 to 6)
M_{2acc}	Nm	Maximum permitted acceleration torque on the gear unit output
M_{2acc^*}	Nm	Existing acceleration torque on the gear unit output
M_{2eff^*}	Nm	Existing effective torque on the gear unit output
M_{2eq^*}	Nm	Existing equivalent torque on the gear unit output



Formula symbols	Unit	Explanation
M_{2N}	Nm	Nominal torque on the gear unit output (relative to n_{1N})
M_{2NOT}	Nm	Emergency off torque of the gear unit at gear unit output for max. 1000 load changes
M_{2NOT^*}	Nm	Existing emergency off torque for the gear unit on the gear unit output
M_{2th}	Nm	Thermal limit torque on the gear unit output
M_{op}	Nm	Torque of motor in the operating point from the motor characteristics for n_{1m^*}
n_{1m^*}	rpm	Existing average input speed
n_{1max^*}	rpm	Existing maximum input speed
n_{1maxDB}	rpm	Maximum permitted input speed of the gear unit in continuous operation
n_{1maxZB}	rpm	Maximum permitted input speed of the gear unit in cyclic operation
$ n_2 $	rpm	Amount of the output speed
$n_{2m,1^*} - n_{2m,6^*}$	rpm	Existing average output speed in the respective time segment (1 bis 6)
n_{2m^*}	rpm	Existing average output speed
n_N	rpm	Nominal speed: the speed for which the nominal torque M_N is specified
S	–	Characteristic load value: quotient of nominal gear unit and motor torque without taking the thermal output limit into consideration. Represents a dimension for the reserve of the geared motor.
t	s	Time
$t_1^* - t_6^*$	s	Duration of the relevant time segment (1 to 6)

Check the following conditions for operating points other than the nominal point specified in the selection tables M_{2N} .

$$n_{1m^*} \leq \frac{n_{1maxDB}}{fB_T}$$

$$n_{1max^*} \leq \frac{n_{1maxZB}}{fB_T}$$

$$M_{2eff^*} \leq M_{2th}$$

$$M_{2acc^*} \leq M_{2acc}$$

$$M_{2NOT^*} \leq M_{2NOT}$$

$$M_{2eq^*} \leq M_{2N} \cdot \frac{S}{fB_{op} \cdot fB_t}$$

The values for n_{1maxDB} , n_{1maxZB} , M_{2acc} , M_{2NOT} , M_{2N} and S can be found in the selection tables.

The values for fB_T , fB_{op} and fB_t can be found in the relevant tables in this section.

Calculate the thermal limit torque M_{2th} for a duty cycle > 50 %.

Example of cycle sequence

The following calculations refer to a representation of the power consumed on the output based on the following example:

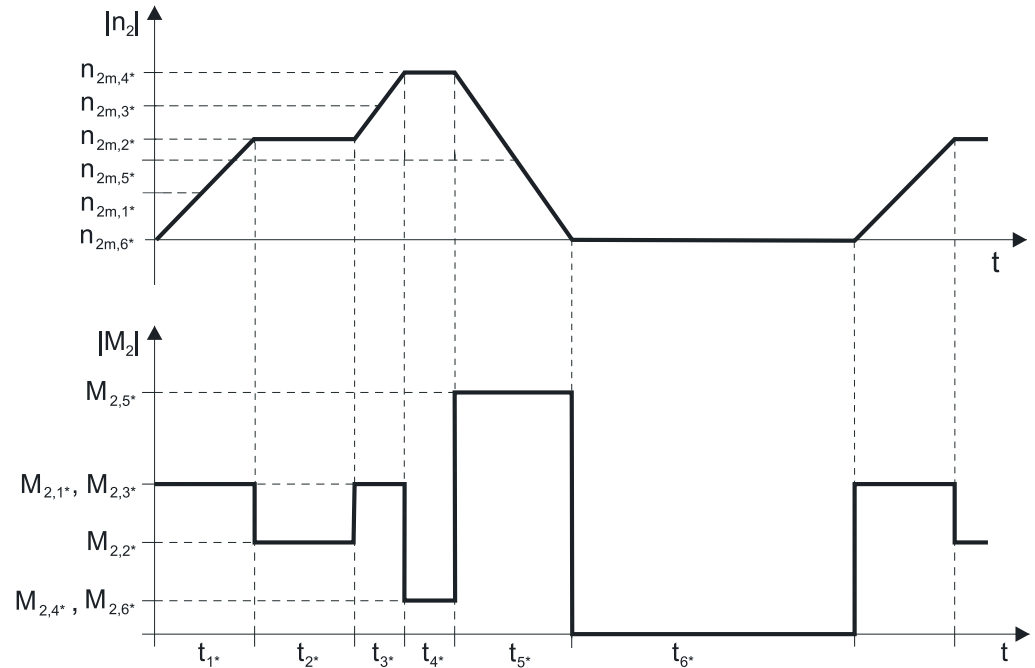

Calculation of the existing average input speed

$$n_{1m*} = n_{2m*} \cdot i$$

$$n_{2m*} = \frac{|n_{2m,1*}| \cdot t_{1*} + \dots + |n_{2m,n*}| \cdot t_{n*}}{t_{1*} + \dots + t_{n*}}$$

If $t_{1*} + \dots + t_{5*} \geq 20$ min, determine n_{2m*} without pause t_{6*} .

For the values for the gear ratio i , see the selection tables.

Calculation of the existing effective torque

$$M_{2eff*} = \sqrt{\frac{t_{1*} \cdot M_{2,1*}^2 + \dots + t_{n*} \cdot M_{2,n*}^2}{t_{1*} + \dots + t_{n*}}}$$

Calculation of the existing equivalent torque

$$M_{2eq*} = \sqrt[3]{\frac{|n_{2m,1*}| \cdot t_{1*} \cdot |M_{2,1*}|^3 + \dots + |n_{2m,n*}| \cdot t_{n*} \cdot |M_{2,n*}|^3}{|n_{2m,1*}| \cdot t_{1*} + \dots + |n_{2m,n*}| \cdot t_{n*}}}$$

Calculation of the thermal limit torque

For a duty cycle $ED > 50\%$, calculate the thermal limit torque M_{2th} for the existing average input speed n_{1m*} . (With $K_{mot,th} \leq 0$ you must reduce the average input speed n_{1m*} accordingly or select a different size for the geared motor.)

$$M_{2th} = M_{op} \cdot i \cdot K_{mot,th}$$

$$K_{mot,th} = 0,93 - \frac{a_{th}}{1000} \cdot fB_T \cdot \left(\frac{n_{1m*}}{1000}\right)^3$$

For the values for i and a_{th} , see the selection tables.

The values for fB_T can be found in the relevant tables in this section.

The motor characteristics can be found in section [▶ 24.3], including the value for the torque of the motor in the operating point M_{op} at the determined average input speed n_{1m*} . Note the size, nominal speed n_N and cooling type of the motor. The illustration below shows an example of reading the torque M_{op} of a motor with convection cooling in the operating point.

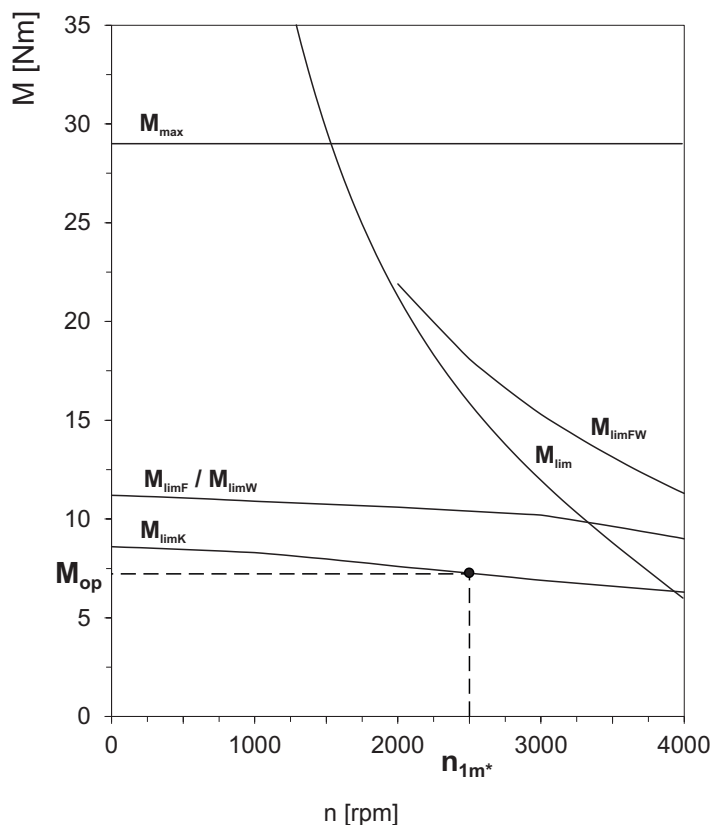

Operating factors

Operation mode		fB_{op}
Consistent continuous operation		1.00
Cyclic operation		1.00
Cyclic operation - reversing load		1.00
Runtime		fB_t
Daily runtime ≤ 8 h		1.00
Daily runtime ≤ 16 h		1.15
Daily runtime ≤ 24 h		1.20
Temperature		fB_T
Motor cooling	Surrounding temperature	
EZHP_U (with convection cooling)	≤ 20 °C	1.0
	≤ 30 °C	1.1
	≤ 40 °C	1.25
EZHP_W (with water cooling)	≤ 20 °C	0.9
	≤ 30 °C	1.0
	≤ 40 °C	1.15

Instructions

- The maximum permitted gear unit temperature (see General product features sections) must not be exceeded. Doing so may result in damage to the geared motor.
- When braking from full speed (for example when the power fails or when setting up the machine), note the permissible gear unit torques (M_{2acc} , M_{2NOT}) in the selection tables.



24.7.2 Permissible shaft loads

Formula symbols	Unit	Explanation
C_{2k}	Nm/ar-cmin	Tilting stiffness
ED	%	Duty cycle relative to 20 minutes
F_{ax}	N	Permitted axial force on the output
F_{2ax}^*	N	Existing axial force on the gear unit output
F_{2ax100}	N	Permitted axial force on the gear unit output for $n_{2m^*} \leq 100$ rpm
$F_{2ax,eq}^*$	N	Actual equivalent axial force on the gear unit output
F_{2axN}	N	Permitted nominal axial force on the gear unit output
F_{2rad}^*	N	Existing radial force on the gear unit output
$F_{2rad100}$	N	Permitted radial force on the gear unit output for $n_{2m^*} \leq 100$ rpm
F_{2radN}	N	Permitted nominal axial force on the gear unit output
$F_{2rad,acc}^*$	N	Actual radial acceleration force on the gear unit output
$F_{2rad,acc}$	N	Permitted radial acceleration force on the gear unit output
F_{2rad,acc,n^*}	N	Actual radial acceleration force on the gear unit output in the n-th time segment
$F_{2rad,eq}^*$	N	Existing equivalent force on the gear unit output
L_{10h}	h	Bearing service life
M_{2k}^*	Nm	Existing breakdown torque on the gear unit output
M_{2k100}	Nm	Permitted breakdown torque on the gear unit output for $n_{2m^*} \leq 100$ rpm
$M_{2k,acc}$	Nm	Permitted acceleration breakdown torque on the gear unit output
$M_{2k,acc}^*$	Nm	Actual acceleration breakdown torque on the gear unit output
M_{2k,acc,n^*}	Nm	Actual acceleration breakdown torque on the gear unit output in the n-th time segment
$M_{2k,eq}^*$	Nm	Existing equivalent breakdown torque on the gear unit output
M_{2kN}	Nm	Permitted nominal breakdown torque on the gear unit output
n_{2m^*}	rpm	Existing average output speed
n_{2m,n^*}	rpm	Existing average output speed in the n-th time segment
t_{n^*}	s	Duration of the n-th time segment
x_2	mm	Distance from shaft shoulder to the point of application of force
y_2	mm	Distance from shaft axes to the point of application of axial force
z_2	mm	Distance from shaft shoulder to the center of the output bearing

The values specified in the tables apply to permitted shaft loads:

- For shaft dimensions according to the catalog
- For output speeds $n_{2m^*} \leq 100$ rpm ($F_{2axN} = F_{2ax100}$; $F_{2radN} = F_{2rad100}$; $M_{2kN} = M_{2k100}$)
- Only if pilots are used (housing, flange hollow shaft)