

Industrial Identification

Product Group Brochure
Optical Identification
RFID



Your automation, our passion.

pf PEPPERL+FUCHS

Find Your Device in Just a Few Clicks

Go online. Specify your requirements. Select your device. You can find the right solution for your application in just a few clicks. If you have any questions, our experts are available to take your call.

Online Search on the Pepperl+Fuchs Website

Enter the model number in the search field on the Pepperl+Fuchs website and get to your product selection immediately. Model numbers can be found in this brochure in the technical data summaries.

Or you can navigate through our range of product families and groups. Product selectors help you select the optimal identification device.

For example,
"OPC120W"

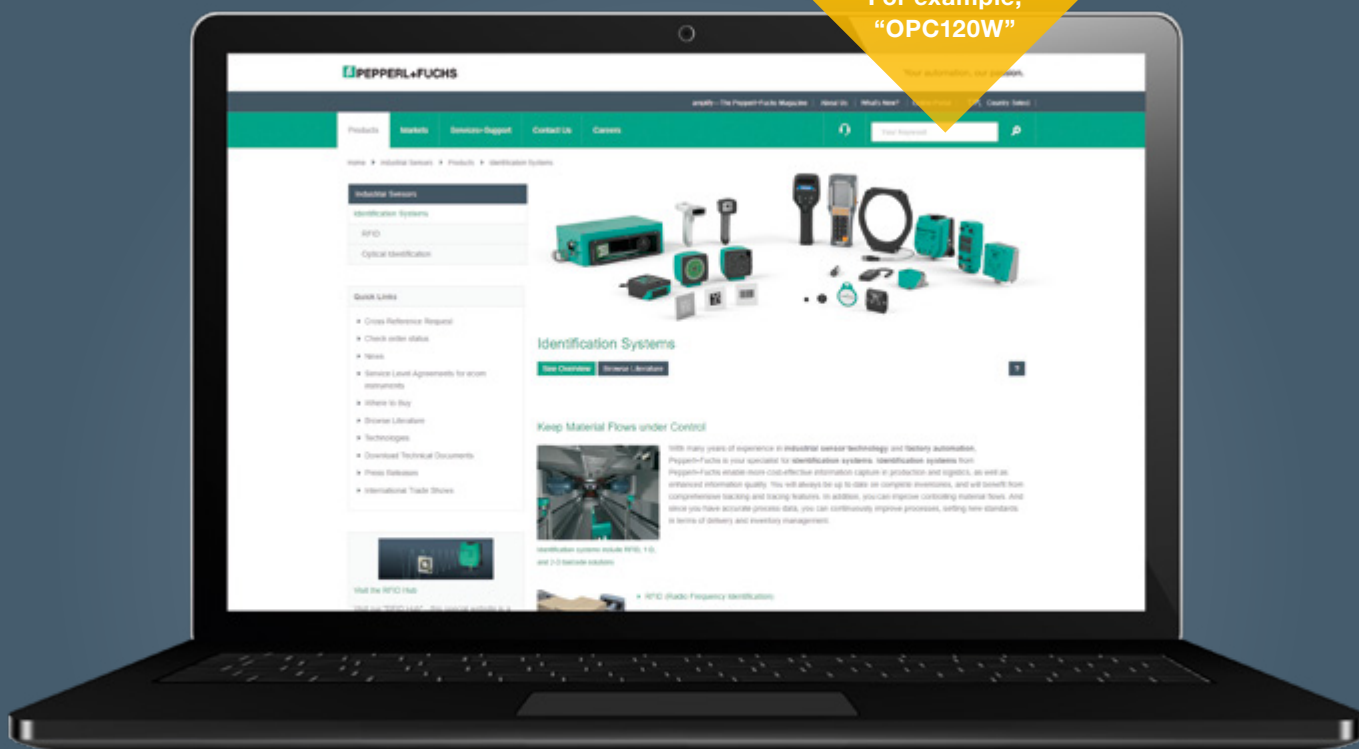

Contents

Identification Systems from Pepperl+Fuchs	4
Optical Identification—Overview and Technology	6
Stationary 2-D Code Readers	10
Mobile 2-D Code Readers	14
Barcode Scanners	20
OIT High-Temperature Identification Systems	24
RFID—Overview and Technology	26
IDENTControl Control Interfaces, IO-Link Master	30
LF Read/Write Heads	34
HF Read/Write Heads	38
UHF Read/Write Heads	42
Tags	46
Handhelds	48
Devices for Hazardous Areas	50

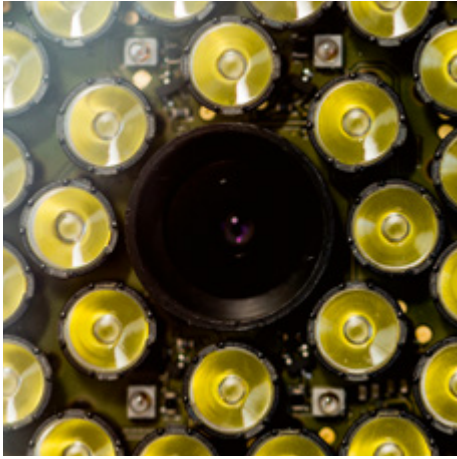

Identification Systems

Two Technologies, One Goal: Process Transparency

Identification systems guarantee reliable, transparent processes and provide the user with a competitive advantage. Depending on your requirements, Pepperl+Fuchs offers camera and RF (radio frequency) systems. Our experts will help you to find the perfect identification solution for every scenario.

RFID—Flexible System Solution for End-To-End Process Transparency

RFID (radio frequency identification) is the clear choice if your application demands a great deal of flexibility. Wireless technology makes it possible to read object information and adapt it if necessary. Another key advantage of RFID is that line of sight between the reader and tag is not required.

Pepperl+Fuchs guarantees the perfect solution for every identification task as a result of years of application expertise and an extensive portfolio of control interfaces, read/write heads, and tags in the standard LF, HF, and UHF frequency ranges.

Optical Identification—Cost-Effective Solution for Track-and-Trace Applications

If you wish to focus on cost-effectiveness, optical identification systems are the best option. Printed and DPM (direct part marked) codes offer a particularly economical solution.

Optical identification systems from Pepperl+Fuchs guarantee strong reading performance and are highly reliable, even in difficult conditions. Whether they are used for stationary or high-speed reading, mobile identification, or in applications with extreme conditions such as high temperature, these powerful devices always provide the most-up-to-date information on your processes.

Optical Identification

The Reliable Solution for Demanding Conditions

Optical identification systems play a significant role in process reliability and availability in factory automation. These cost-effective solutions guarantee a fully reliable read result, even under demanding conditions and at high speeds. Pepperl+Fuchs offers a wide range of mobile and stationary systems for optical identification that cover all standard code symbologies and boast impressive, powerful functions.



For more information, visit:
www.pepperl-fuchs.com/pf-opto-ident



Technology

The Efficient Solution for Transparent, Reliable Processes

Optical identification systems from Pepperl+Fuchs are used in almost all areas of industrial automation, helping to improve the transparency and reliability of processes within these industries with lasting results. The systems can be used in any application, be it in challenging ambient conditions, at high scan rates, or in extreme temperatures. The extensive portfolio of stationary readers and handhelds offers the right solution for every identification task, guaranteeing reliability and the highest read quality.

The portfolio of optical identification devices from Pepperl+Fuchs includes various code types and code readers. You will always find the right solution—even for extreme applications.



Stationary Code Readers



Diverse Code Symbologies

Powerful Systems, Impressive Performance

Track-and-trace applications play a crucial role in modern manufacturing processes. They ensure maximum transparency, since they allow all processing steps to be planned, carried out, and tracked. To support these tasks, Pepperl+Fuchs offers an extensive portfolio of stationary and mobile camera systems that are suitable for all standard 1-D and 2-D codes. These powerful devices are quick to integrate and simple to commission, and can be perfectly adapted to the individual application requirements of the customer.

The Right Code for Every Application

Optical identification applications are just as diverse as the codes used in them. These codes can be found printed, laser-etched, or stamped onto various surfaces, which include shiny, reflective, and metallic materials. Despite their numerous differences, the one thing that all codes have in common is the crucial track-and-trace information that they store throughout the entire production or machining process. This data must be read securely and reliably, regardless of whether the data is written on the material itself (DPM) or a stamped code sheet is used at ambient temperatures of up to 500 °C. To assist with these tasks, Pepperl+Fuchs offers a variety of code readers for optical identification, all of which perform well, even in extreme conditions.



Mobile Code Readers



Special Solutions

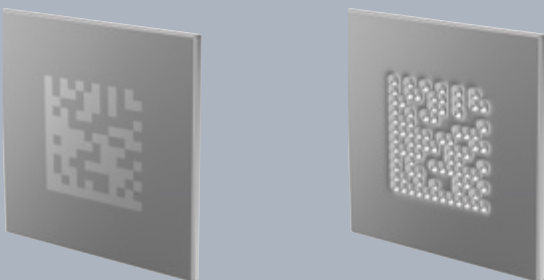

Special Code Sheets

Stationary 2-D Code Readers

Powerful Performance, Whether Stationary or at High Speed



Whether stationary or on the move, printed or directly marked, the stationary readers from Pepperl+Fuchs are capable of completing all identification tasks reliably, accurately, and cost-effectively. The device's simple operation and wide range of powerful features ensure optimal performance.

User-Friendly with High Read Quality

Whether reading standard 1-D and 2-D codes or reading at high speeds, the stationary readers in the OPC120 series are true performance artists, covering the entire spectrum of demanding applications perfectly. Even in the most challenging conditions, these readers provide value both when stationary and at high speed. Features such as print presence detection, logo comparison, and multi-window with up to four windows ensure efficiency and reliability in the reading process. In addition, the devices are incredibly user-friendly, offer an automatic error memory, and are capable of reading codes on reflective surfaces.

Typical Applications

- Print and paper industry: print presence detection, logo comparison, and code reading
- Automotive industry: track-and-trace applications (and direct part marking)
- Semiconductor industry: monitoring of SMD placement
- Warehousing and material handling: code reading on boxes and trays

Highlights

- Reliable 1-D/2-D code reading on highly reflective surfaces
- High-speed code reading of up to 10 m/s at 100 readings/second
- Intelligent functions such as print presence detection, logo comparison, and multi-window

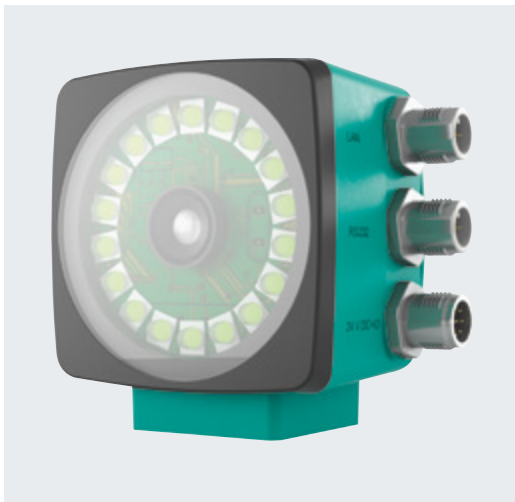

OPC120W Series—Strong Performance for Standard Applications

The OPC120W series is the ideal choice for all standard applications. The high depth of focus enables 1-D and 2-D codes to be read at various distances and in various sizes, using just one setting. With the device’s intelligent features such as print presence detection, logo comparison, and multi-window, reliable reading behavior is guaranteed at all times—both when stationary and at high speeds of up to 6 m/s at 30 readings/second. The user-friendly software allows the device to be adapted to the individual application requirements of the customer.



OPC120P Series—Designed for Demanding Applications

The OPC120P series is capable of impressive high-speed code reading of up to 10 m/s at 100 readings/second. Because of its polarization filter technology, the device is able to reliably read 1-D and 2-D codes even from highly reflective surfaces. The exceptionally high depth of focus enables 1-D and 2-D codes to be read at various distances and in various sizes using just one setting.

The devices offer print presence detection, logo comparison, multi-window, and a PROFINET interface with an integrated switch as additional features. The user-friendly software allows the device to be flexibly adapted to individual application requirements.

Excerpt of technical data	OPC120W-F200-R2	OPC70P-F201-R2-45	OPC120P-F201-R2	OPC120P-F201-B17
Read field	Max. 105 mm x 65 mm	Max. 35 mm x 55 mm	Max. 105 mm x 65 mm	
Read distance	70 mm to 180 mm	45 mm to 90 mm	70 mm to 180 mm	
Object speed	6 m/s	10 m/s		
Code symbologies	Data Matrix, Code 39, Code 128, Int 2 of 5, EAN13, Pharmacode			Data Matrix
Min. module size	0.2 mm	0.15 mm	0.2 mm	0.2 mm
Interfaces	Ethernet TCP/IP, RS232, I/Os			PROFINET
Protection class	IP67			

Stationary 2-D Code Reader Applications

Versatility through Powerful Features



OPC120 series code readers offer a variety of features that facilitate a wide range of applications. No matter how complex the requirement or how challenging the surface, all codes are reliably detected.

The Unique Features of the OPC Series

Print presence control is used to inspect changing structures, ensuring that the requisite production data, serial numbers, and shelf life details are present in the process.

The **logo comparison** feature not only ensures that the necessary logos are present, but checks that these logos are positioned correctly as well. If these logos are missing or are printed in the wrong place, the affected objects will be separated out from the rest.

The **multi-window feature** of the OPC120 allows the read range to be divided into up to four fields, which are detected and evaluated separately. This makes it possible to read and compare the codes in a single step, and to check whether the logos are present and printed correctly. This guarantees reliability and ensures that processes are significantly shorter and more efficient.

Demanding Code Reading in Electronics Manufacturing

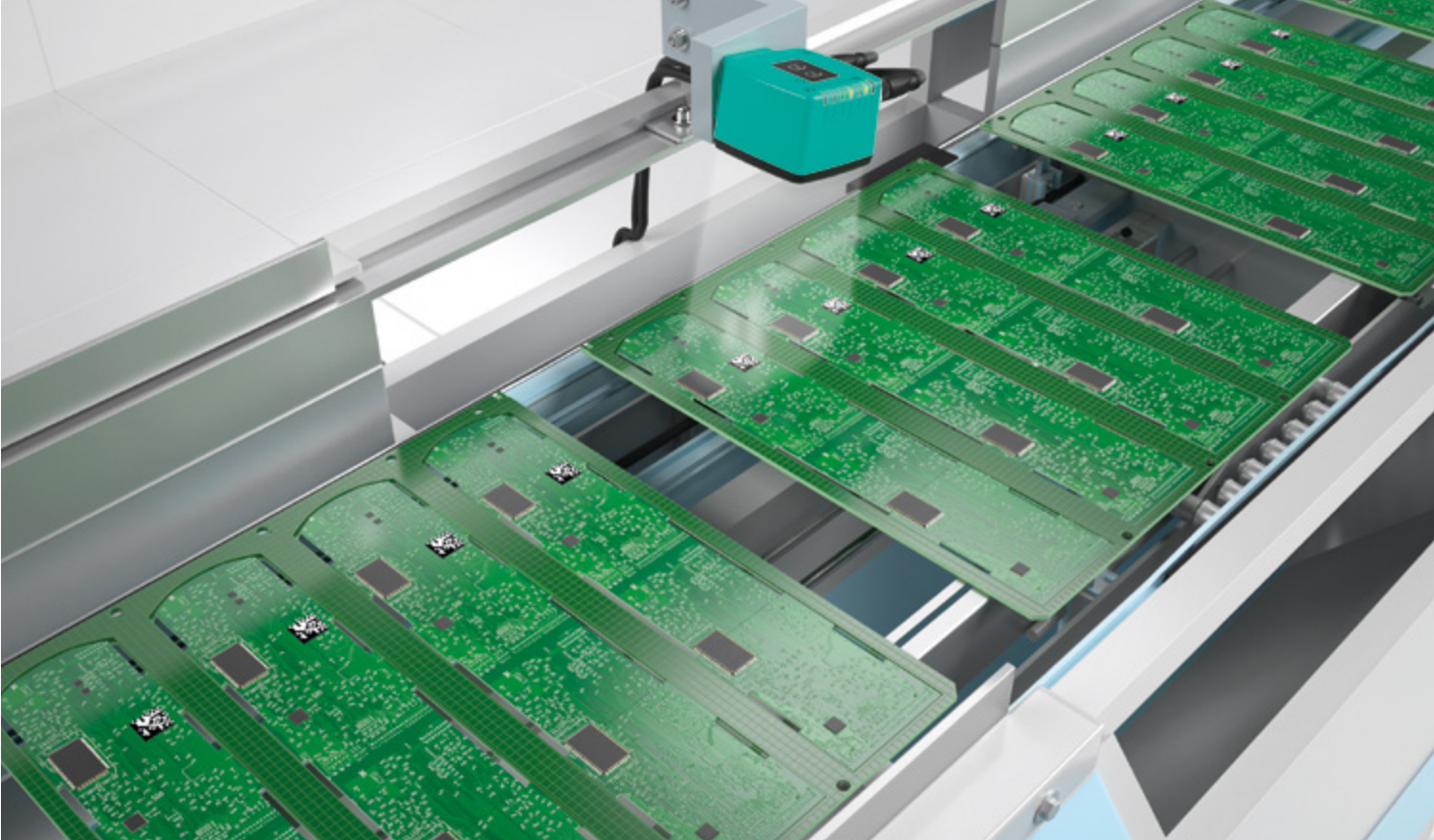

OPC120 series code readers are synonymous with impressive features and an extensive range of applications, and they were designed for particularly challenging situations. No matter how complex the requirements or how challenging the surface characteristics are, all codes are reliably detected.

Reading DPM Codes on PCBs

Efficient, interference-free production is essential for every manufacturing company. However, for automotive suppliers in particular, being able to track products from start to finish is critical. This is evident, for example, in the case of faulty PCBs in the control electronics of braking systems. Here, it must be possible to reliably identify and track the components throughout the entire manufacturing process.

To ensure this, the individual electrical assemblies are provided with DPM codes which contain unique data such as the item number, production location, time, date, and serial number. The products can then be clearly identified by an OPC120P code reader before they enter the placement machines and

before/after each test step. The device's unique polarization filter technology means that the code can be read from the reflective surface of the PCBs with complete accuracy.

In addition, the high depth of focus of the OPC120P allows large and small codes to be read at various distances using just one setting. Thanks to its exceptionally flexible handling, the device is suited to a wide range of applications as well.

Mobile 2-D Code Readers

Intelligent Solution for Mobile Identification



Handheld readers from Pepperl+Fuchs offer the perfect solution for every mobile identification application. Individual programming options allow the device to be perfectly adapted to the customer's application, while intelligent features ensure outstanding read quality, even on extremely challenging surfaces.

Easy to Use, Best Read Performance

OHV series handheld readers provide read performance, ease of use, and adaptability to customer-specific requirements. The devices are capable of reading 1-D and 2-D codes with a high level of reliability, even on reflective surfaces, and cover all standard code symbologies on the market. A patented dual lens allows codes of various sizes to be read using just one setting. To ensure maximum process reliability, each read operation is confirmed by acoustic, tactile, and visual feedback.

Various programming options allow the device to be adapted to individual applications in the most effective way via control codes on the device itself, via the Vision Configurator graphical user interface, or via JavaScript. This means that the handheld readers from Pepperl+Fuchs offer perfect solutions for any mobile identification application.

Typical Applications

Mobile identification tasks in major industries such as the mechanical engineering, automotive, packaging, warehousing, and material handling industries, including:

- Warehouse management: data collection in ERP systems and inventory applications
- Code reading on pharmacy labels, job routing, photo books, etc.
- Identification at manual workstations
- Automotive industry: DPM code reading on engine blocks and PCBs

Highlights of the OHV Series

- Excellent read quality
- Reliable 1-D/2-D code reading on reflective surfaces
- Application flexibility thanks to a sturdy housing and IP65 rating
- High process reliability through user feedback (acoustic, tactile, and visual signals)
- Can be programmed individually for specific application requirements

PROFINET Gateway for Connecting the OHV Series

The compact gateway (OHV-F230-B17) is the ideal solution for the cost-effective connection of handheld readers to the control panel. The gateway is equipped with a PROFINET interface with a built-in switch and is particularly easy to integrate via a standardized M12 plug. An LED status display for communication monitoring, inputs, and outputs makes operating the device simple.

More information can be found online.



Mobile 2-D Code Readers

The Portfolio at a Glance



OHV100—Compact Solution for Demanding Tasks

The wired OHV100 is a compact handheld reader and the perfect choice for demanding applications both when stationary and in motion. The device offers the highest level of read performance and detects a variety of code symbologies. To ensure efficiency for your workflow, the handheld reader can also be mounted for stationary applications. In this case, the automatic motion detection is activated and the device reads the codes independently whenever an object passes by.



OHV1000—Ideal for Reading DPM Codes

The OHV1000 is a wired handheld reader for reading DPM codes (needle-punched, laser-inscribed, and printed) and printed 1-D or 2-D codes. The patented dual lens, paired with a high resolution of 1.2 megapixels, allows DPM codes as small as 0.1 mm to be read as reliably as long barcodes. Automatic motion detection makes the device ideal for highly efficient code detection at manual workstations.



OHV200/OHV2000—Sturdy Devices for Indoor and Outdoor Applications

This series consists of wireless handheld readers for all standard 1-D/2-D codes (OHV200). In addition, the OHV2000 offers the option of DPM code reading. The corresponding charger is equipped with a Bluetooth modem for transferring data automatically. Alternatively, a USB connection is provided. In batch mode, up to 30,000 read results can be stored directly on the handheld reader itself. This saves time because the battery can be charged and data can be transferred in a single step. The device’s long battery life guarantees that work processes can be carried out continuously. For maximum operating convenience, the series is also available without a handle.



OHV300—Intelligent Handheld Reader for Storage Systems

The OHV300 handheld reader effortlessly completes tasks ranging from product registration to complete warehouse management. To add goods to the inventory, the user can input the product-specific data via the code reader or the keyboard. Saved data such as location and quantity can then be identified at any time by simply reading the codes. The keyboard and integrated color screen ensure that the controls and results display are convenient to use. For further processing and backup, the data can be exported to ERP systems in tabular form by connecting the OHV300 handheld reader wirelessly via Bluetooth, to the PC USB charger, or to smartphones and tablet computers.

Excerpt of technical data	OHV100-F222-R2	OHV1000-F223-R2	OHV200-F220-B15 (without handle) OHV200-F221-B15 (with handle)	OHV300-F224-B15	OHV2000-F221-B15
Read field	Max. 190 mm x 290 mm				
Read distance	40 mm to 310 mm	0 mm to 200 mm	40 mm to 310 mm		
Interfaces	USB, RS-232	USB 2.0, RS-232	Bluetooth, USB (via charger)	Bluetooth (class II), USB	Bluetooth (class II), USB 2.0

Mobile 2-D Code Reader Applications

Powerful Performance for Processes in the Automotive Industry

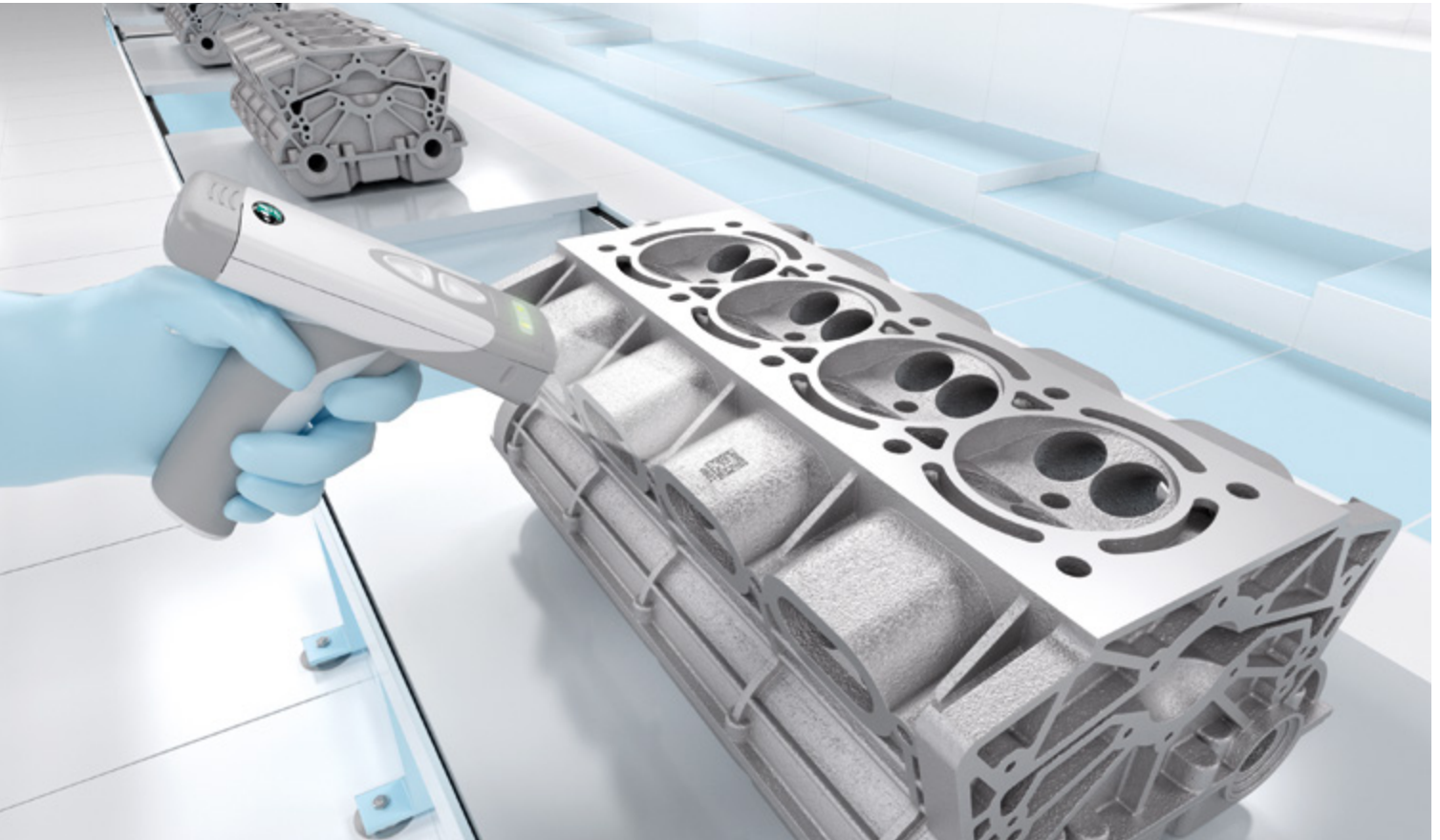

In many areas of the automotive industry, reliably identifying direct part marked codes is essential for ensuring a reliable process flow. To aid with this, the OHV series from Pepperl+Fuchs offers powerful handheld readers that guarantee exceptional read quality, even on reflective surfaces.

DPM Code Reading for Assigning Car Parts

The reliable identification of parts with dot-peened codes plays a vital role in the automotive industry. During the final assembly of vehicles, engine blocks are transported via conveyor belts to the bodyshell and suspension stations. It must be ensured that employees are able to assign each engine to its designated car body with absolute certainty during this process. For this reason, a code is permanently laser-inscribed or dot-peened onto the side of each engine block. It must be possible to identify this code reliably.

OHV2000 series compact handheld readers from Pepperl+Fuchs are perfectly suited for use at the extraction point. The patented polarization filter technology allows codes to be read from the reflective surfaces of metal objects with complete accuracy.

The dual lens and 1.2 million pixel resolution make it possible to read small and large codes at various distances. At the same time, the target projection makes it easier to see the codes, and read feedback is clearly communicated through vibration, an LED display, and an audible signal.

Vision Configurator software is used to create rule sets for formatting read results for easy integration into ERP systems without the need for any programming. The read data is then transferred via Bluetooth or by plugging the reader into the charger.

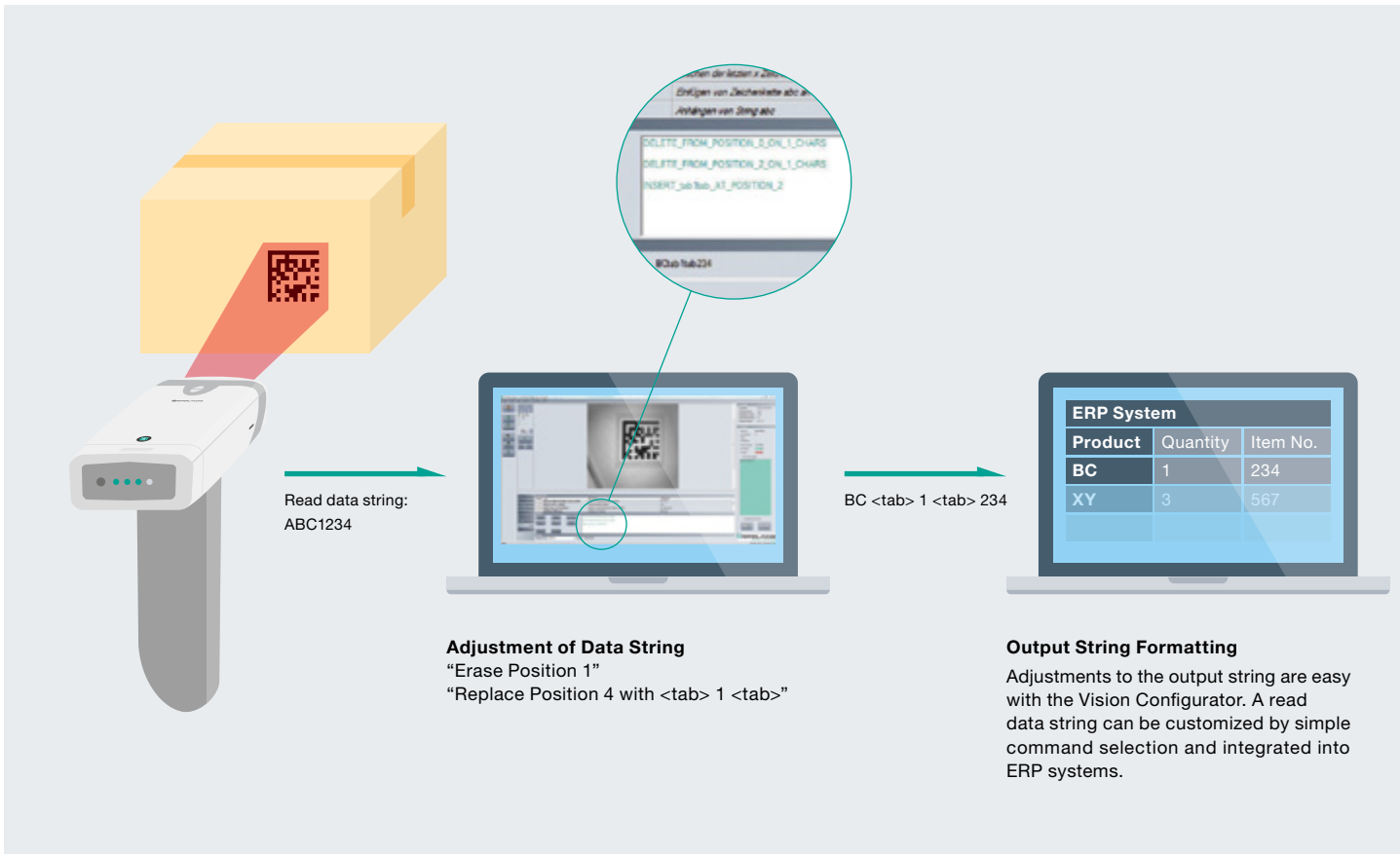

Extra Flexibility

The OHV series of handhelds can be conveniently adapted to any application using control codes, the Vision Configurator, or JavaScript.

Perfectly Adapted to the Application—It's Easy with Vision Configurator

Vision Configurator software from Pepperl+Fuchs enables a wide range of parameters to be configured with the click of a mouse. A wide range of features such as optimization, exposure time, and code selection can be configured with ease. Live images assist with configuration, which facilitates fine-tuning in no time at all. JavaScript makes it possible to display complex applications without an external PC.

The software can be found at:
www.pepperl-fuchs.com/pf-vision-configurator



Barcode Scanners

Wide Range of Applications, High Efficiency



The barcode scanners from Pepperl+Fuchs ensure complete process reliability, even at low temperatures, long distances, and extremely high scan rates, meaning that the devices are perfect for covering a wide range of applications. Up to 32 scanners can be networked with one another to handle high-speed applications, and they ensure a high level of efficiency by utilizing every step in the process chain.

From High Speeds to Low Temperatures

Barcodes are now ubiquitous in industry and trade—but when it comes to reading barcodes, every application has its own special requirements. Different sizes and distances, variable speeds and varying levels of damage; Pepperl+Fuchs has got this vast spectrum of requirements covered with its two extremely powerful reader series. Read distances of up to 2.5 meters, scan rates of up to 1200 scans per second, and code sizes of just 0.2 millimeters are processed with total accuracy and incredible efficiency. For high-speed applications, up to 32 scanners can be networked to form an integrated solution. A reliable process flow and excellent read performance is guaranteed at all times, even at temperatures as low as $-35\text{ }^{\circ}\text{C}$.

Typical Applications

- Warehousing and material handling: code reading on boxes, pallets, and trays
- Print and paper industry: code reading in enveloping machines
- Packaging industry: verification and assignment of products to outer packaging
- Automotive industry: odette label reading

Highlights

- Networking of up to 32 scanners for high-speed applications
- High scan rates of up to 1200 scans/second for the fastest processing speeds
- Automatic and programmable focus settings for continuous process flows
- Reliable code reconstruction for reading damaged or rotated barcodes
- Wide range of applications through an extended temperature range of up to $-35\text{ }^{\circ}\text{C}$

Various connector boxes are available for connecting the barcode scanners from Pepperl+Fuchs to fieldbus systems. These connector boxes and other accessories can be found online at www.pepperl-fuchs.com.



VB14N Series—Ideal Even for Low-Temperature Applications

The compact line scanners for 1-D barcodes offer unmatched read performance, even with difficult contrast ratios. A function key enables easy commissioning of the device and convenient teach-in of the codes. Up to 32 devices can be networked with one another via ID-NET™ to form a complete solution. The VB14N-T version is equipped with an integrated heater that has a quick warm-up phase (max. 20 minutes). This means that the scanner can resist ambient temperatures as low as -35 °C, and is ideal for deep-freeze environments.



VB34 Series—Reliable over Large Distances

The VB34¹ series is optimized for reading codes over distances of up to 2500 mm. The automatic focus of the optical system can be individually programmed and tailored to specific application requirements, while the integrated code reconstruction for damaged and rotated barcodes significantly increases process reliability. Since the entire scanner unit is mounted in a way that allows for adjustment, the device can be tailored to suit the application as closely as possible. The devices are equipped with various interfaces and are available with an optional oscillating mirror, which means that integrating the devices into existing system environments is quick and seamless.

Excerpt of technical data for the VB14N series	VB14N-300 (-R)	VB14N-600 (-R)	VB14N-400-T (-R)	VB14N-600-T (-R)
Read distance	40 mm to 300 mm	190 mm to 600 mm	60 mm to 400 mm	190 mm to 600 mm
Min. resolution	0.2 mm (8 mils)	0.35 mm (14 mils)	0.2 mm (8 mils)	0.35 mm (14 mils)
Scanning frequency	500 scans/s to 800 scans/s	600 scans/s to 1000 scans/s		
Interface	R232 and RS485			

Excerpt of technical data for the VB34 series	VB34 linear version	VB34 integrated oscillating mirror version
Max. read distance	2500 mm	
Resolution	0.2 mm (8 mils)	
Scanning frequency	600 to 1200 scans/s (programmable)	
Main interface	RS232, RS485, or PROFIBUS	
Auxiliary interface	RS232	
Serial model number/PROFIBUS	VB34-2500-(P)	VB34-2500-OM-(P)

¹ The VB34 product family is not available for sale in North America.

Barcode Scanner Applications

High Performance at the Lowest Temperatures



The temperature of deep-freeze storage facilities places considerable demands on the sensor technology in barcode scanners. Devices that are typically used in these applications must be able to reliably identify barcodes at all times. The VB14N-T series from Pepperl+Fuchs is specially designed for such an extreme environment, delivering reliable read results at all times at temperatures as low as -35 °C .

Strong Performance in Low-Temperature Applications

In the food industry, end-to-end cold chains play a vital role in ensuring the quality of the product. For this reason, frozen products must never be stored at a temperature greater than -18 °C . Products are transported to cold storage on trays that are marked with barcodes. These codes can be used to easily identify products, allowing them to be transported to the next step in the process chain.

Challenging ambient conditions such as those in the cold chain require scanners that work quickly and with complete accuracy, even at the lowest temperatures. However, the extreme negative temperatures can have a negative impact on the readability of the code itself. To overcome this issue and guarantee short throughput times as well as minimal

fault rates, even codes that are difficult to read must always be quickly and reliably detected. This poses a real challenge for sensor technology.

Tackling this challenge requires highly specialized scanners such as the VB14N-T with an integrated heater, which ensures optimal read results at temperatures from -35 °C to $+45\text{ °C}$. The short warm-up time of no more than 20 minutes means that the device is ready to use in no time at all, with a reduced maximum energy consumption of 9.6 watts. High-performance optics and code reconstruction guarantee that barcodes that are difficult to detect can be read with total accuracy, while the compact housing design means that the device can be installed in tight spaces.

Efficiency through Intelligent Networking

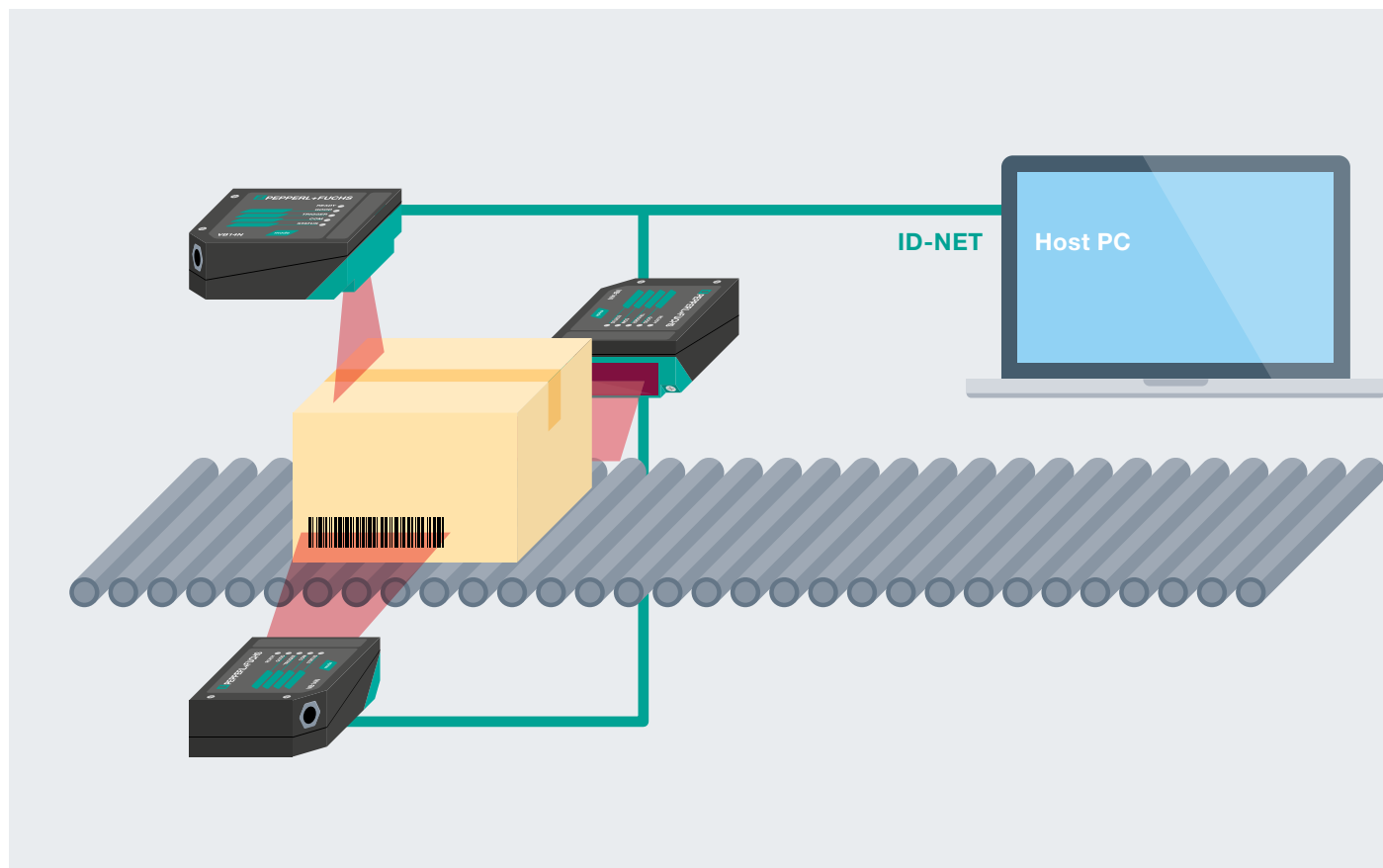

The specially developed data communication system ID-NET allows up to 32 units from the VB14N barcode scanner series to be networked to form one integrated total solution. This allows the highest cycle rates to be achieved, ensuring greater efficiency.

Every System Operates at Peak Performance

Networking the barcode scanners allows for simultaneous detection of multiple barcodes, which might be in different positions on a packaged item. When doing so, the system only occupies one fieldbus address, through which all information flows quickly and efficiently. This enables high cycle rates and supports efficient process flows.

OIT High-Temperature Identification Systems

Reliable Code Reading at High Temperatures



The robust stainless-steel code plates are available in different versions.

Cyclic temperature changes, continuous high temperatures, and the effects of dust and paint place high demands on materials and technology. The durable OIT high-temperature identification system was developed with these demands in mind. The system ensures a reliable read performance and smooth process flow, even at temperatures of up to 500 °C.

Premium Performance at High Temperatures

Drying systems, painting lines, galvanizing plants, and bakeries operate under special production conditions in terms of temperature and pollution. Developed specifically to withstand these extreme conditions, the durable OIT high-temperature identification system from Pepperl+Fuchs ensures smooth process flows in the toughest conditions. Highly reliable read performance is guaranteed, even at temperatures up to 500 °C.

Typical Applications

- Automotive industry: identification in bodyshell production, painting lines, galvanizing plants, and drying systems
- Color and paint-processing industry: identification tasks
- Bakeries: identification of baking molds

Highlights

- Heat-resistant code sheets for temperatures up to 500 °C
- Reliable identification, even on contaminated code sheets
- Integrated diagnostic function for reliable process flows
- Maintenance-free with the one-piece housing concept; no additional components
- Simple connection to all standard controllers

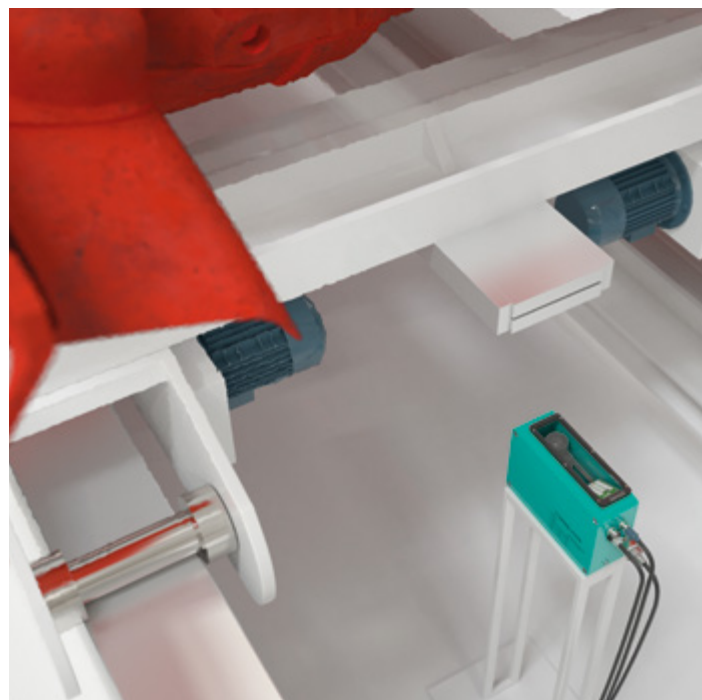
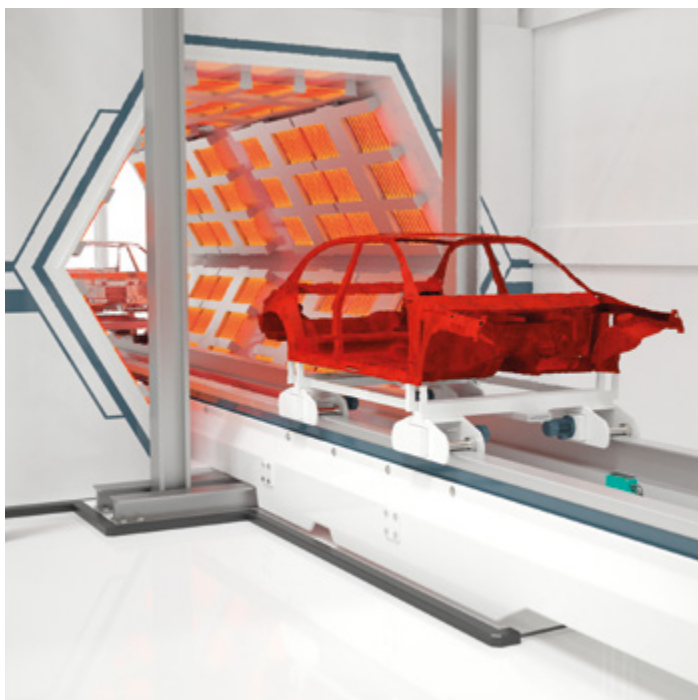

Perfect for Identification at High Temperatures

In drying systems used in automobile construction, parts are subject to the extreme temperatures of curing ovens for the purpose of curing glued joints and drying paint. Heat-resistant code sheets store the necessary information for each vehicle type and must be reliably identified, even if they are contaminated or carry paint residue. High-temperature identification systems such as the OIT from Pepperl+Fuchs are developed

specifically for this purpose, capable of ensuring strong read performance even under the toughest conditions. The devices can be easily integrated into all standard control panels and are maintenance-free thanks to their one-piece housing concept with no additional components.

Excerpt of technical data	OIT200-F113-B12-CB	OIT300-F113-B12-CB2	OIT500-F113-B12-CB	OIT500-F113-B12-CB3	OIT1500-F113-B12-CB
Read field (max.)	210 mm x 135 mm	210 mm x 160 mm	330 mm x 250 mm	340 mm x 210 mm (at max. read distance)	320 mm x 235 mm
Read distance	140 mm to 200 mm	100 mm to 270 mm	200 mm to 450 mm	CB1: 300 mm to 450 mm CB3: 350 mm to 400 mm	750 mm to 1700 mm
Interfaces	Ethernet TCP/IP				
Code sheet	CB2: perforated matrix 5 x 5 4 decimal digits 1 to 4095			CB1: perforated matrix 6 x 6 6 decimal digits 0 to 999,999 CB3: hole pattern 3 x 12 12 binary digits 1 to 4095	CB1: perforated matrix 6 x 6 6 decimal digits 0 to 999,999

RFID

RFID—The Powerful System for the Most Flexibility

Pepperl+Fuchs offers a complete RFID portfolio that consists of perfectly coordinated components. Across all frequency ranges (LF, HF, UHF), our focus remains the same: compatibility and simple operation. Years of expertise and extensive consultation ensure that our RFID system solutions are perfectly optimized to your individual requirements.

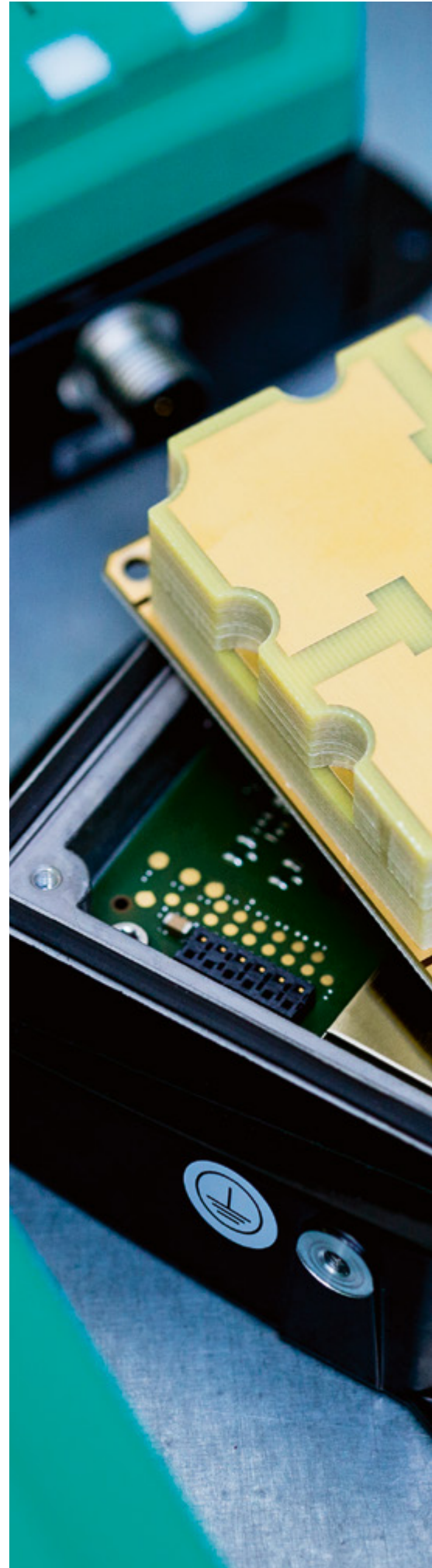

For more information, visit:
www.pepperl-fuchs.com/pf-RFID



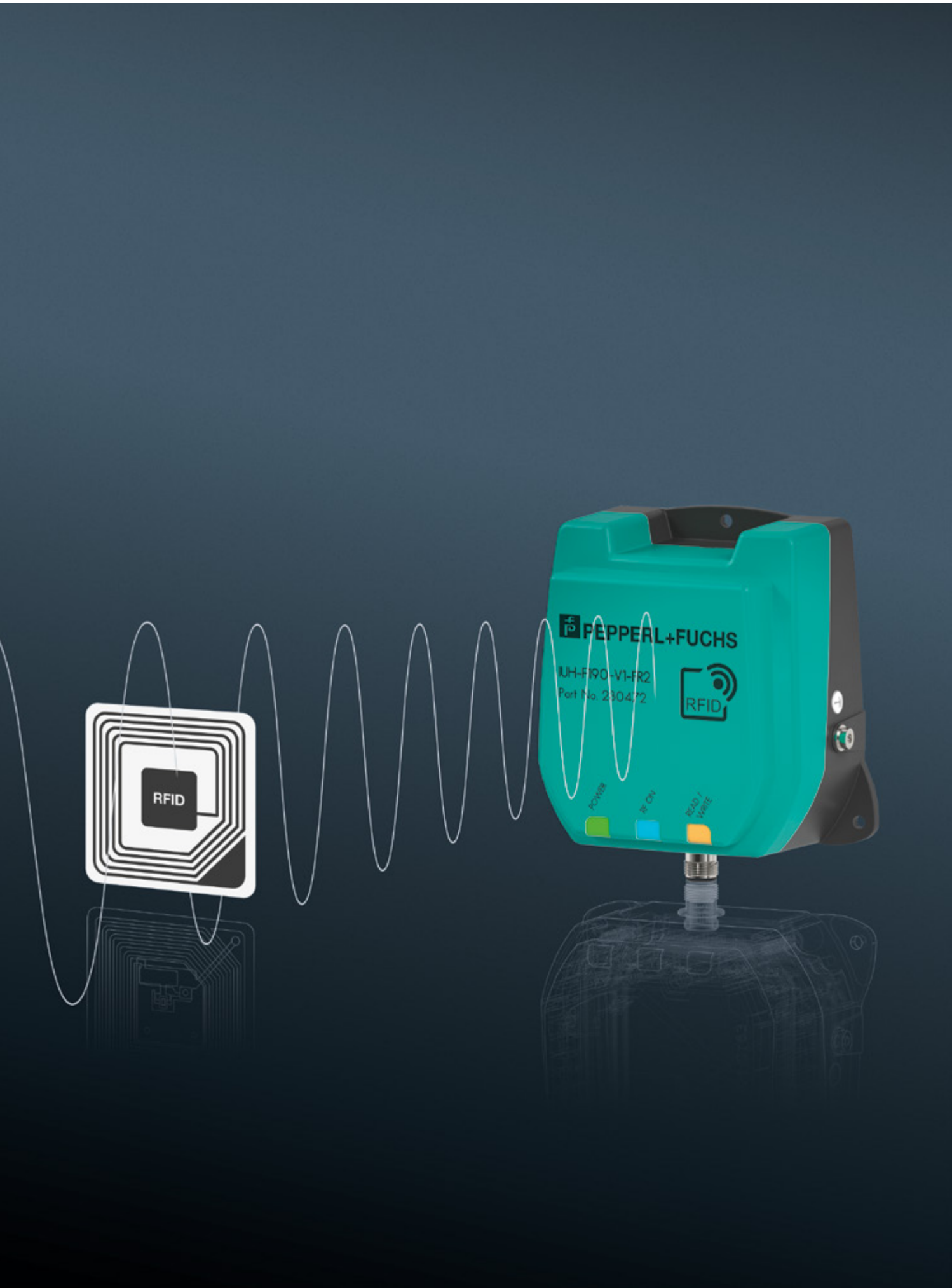

Technology

Reliability and Transparency for Complex Processes

RFID technology from Pepperl+Fuchs is synonymous with optimized production, high cost efficiency, and the greatest transparency in process flows. Decades of experience and sound application expertise are the foundation for our system solution, which consists of perfectly coordinated components that are tailored to the customer's applications down to the last detail.

Noncontact and Highly Efficient

Radio frequency identification, or RFID, plays a crucial role in automation. The technology uses radio waves to identify objects automatically without making contact. Tags serve as databases transmitting information relating to products, goods, and people, and allowing data and material flows to be combined in the most effective way.

Since tags are used to store all process-relevant information locally on the object, production can be controlled on the basis of the object. Track-and-trace applications allow raw materials and products to be assigned and tracked in a clear manner, while RFID allows process flows to become quicker, more transparent, and much more efficient.

Robust and Durable

RFID tags can handle a lot of mechanical wear. This means that RFID is perfectly suited for harsh environments and extreme temperatures. Other advantages for the process flow include detection without a direct line of sight, even at long distances, and efficient multi-tag detection with UHF. In addition, the tags can be clearly identified no matter where they are in the world, are resistant to dirt in comparison with barcodes, and offer unlimited read/write cycles.

Innovative Technology for the Smart Factory

RFID is a key technology when it comes to the latest challenges of automation and the factory of the future. As soon as products are equipped with an RFID tag, they are able to carry information relating to necessary production steps and special requirements. This data can be read out at any time.

Once individual production steps are completed, additional information can be added to the tag. This is how RFID brings fresh momentum and considerable flexibility to all areas of production and logistics. For RFID applications, Pepperl+Fuchs offers complete system solutions with IO-Link technology. These solutions enable efficient, reliable communication between the control and sensor levels in line with Industry 4.0.

Highlights

- One-on-one consulting for application-specific system solutions with perfectly coordinated components
- Components for all frequency ranges (LF, HF, and UHF)
- IDENTControl system: simple system integration, compatible with standard control panels
- IO-Link: new application possibilities, transparency down to the field level



For more information on RFID technology, visit:
www.pepperl-fuchs.com/pf-rfid-hub

Control Interfaces

IDENTControl: A System for the Most Compatibility

The control interfaces in the IDENTControl system can be simply and flexibly integrated into almost any system environment. Furthermore, the control interfaces can be combined with a variety of read/write heads and tags, and are therefore ideal for global use. In addition, the system's wide-ranging compatibility grants the user complete freedom when expanding their own system.

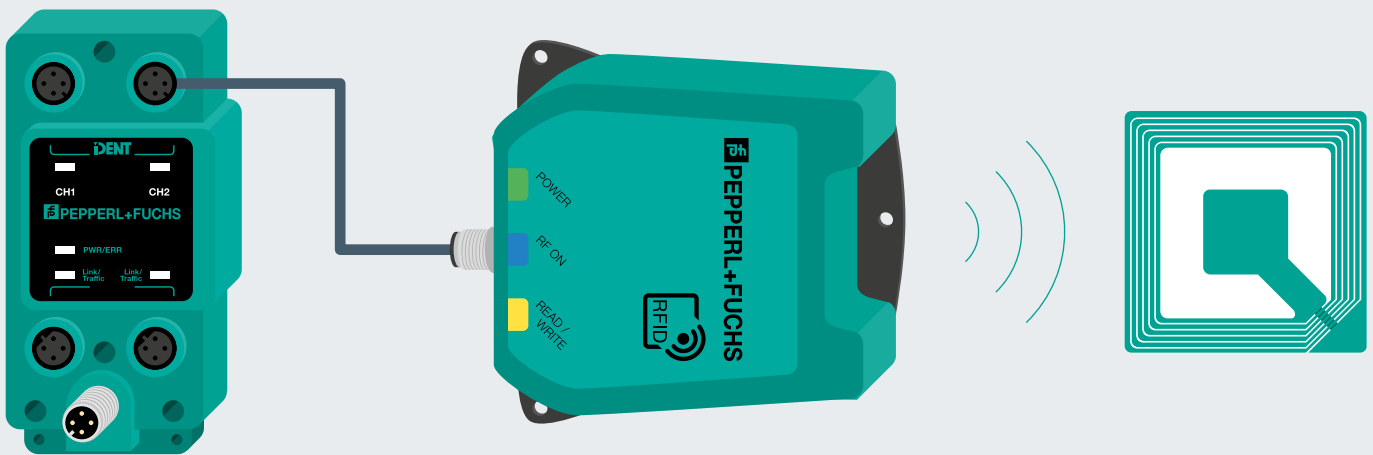

Multiple read/write heads of varying frequencies from the IDENTControl product family from Pepperl+Fuchs can be connected to the IDENTControl and IDENTControl Compact control interfaces. Connecting the devices is simple and hassle-free, ensuring total compatibility.

When a read/write head receives the data stored in a tag via its electromagnetic field, this data is automatically forwarded to the control interface and processed.



IDENTControl Series

The control interfaces in the IDENTControl series allow up to four read/write heads of varying RFID frequencies to be connected at the same time. In addition, it is possible to operate the separate devices jointly and connect trigger sensors. The devices are available for all standard fieldbus types and Ethernet protocols (PROFIBUS, PROFINET, EtherNet/IP, TCP/IP, MODBUS TCP), and can therefore be used around the world. The LC display and function keys make commissioning the devices hassle-free, while the plug-in bus connections guarantee that installation is simple and the device is quick to replace—ensuring that your processes remain uninterrupted.



IDENTControl Compact Series

If installation space is limited, or you have a smaller RFID installation, the control interfaces in the IDENTControl Compact series are the perfect choice. With their compact design, the devices are perfectly suited for decentralized field mounting. They allow two read/write heads to be connected at the same time—or alternatively, one read/write head and one trigger sensor. In addition, the plug-in bus connections make installing the devices quick and simple, ensuring that your processes remain uninterrupted. The LED status display makes it possible to monitor the status of the device and bus communication on a continuous basis, thereby significantly increasing transparency.

- Highlights of the IDENTControl System**
- Connection/evaluation of all RFID frequencies on a single device
 - EMC protection and sturdy, fully encapsulated metal housing for total noise immunity
 - Simple system integration—can be connected to all standard fieldbuses
 - Compact version for decentralized field mounting
 - Display and function keys for easy commissioning
 - Plug-in connections for simple handling

Excerpt of technical data	IC-KP	IC-KP2
Number of channels	up to 4	up to 2
Interfaces	PROFIBUS, PROFINET, EtherNet/IP, TCP/IP, MODBUS TCP, serial	PROFIBUS, PROFINET, EtherNet/IP, TCP/IP, MODBUS TCP, EtherCAT, CC-Link, serial
Degree of protection	IP67	

IO-Link Master

IO-Link Master: Intelligent and Future-Proof

The Ethernet IO modules from Pepperl+Fuchs are synonymous with high efficiency, incredible flexibility, and easy connection. The modules allow you to connect one IO-Link master with up to eight IO-Link devices, allowing you to save on channel costs and benefit from a highly cost-effective application solution. Furthermore, end-to-end communication between the control and sensor levels forms the basis for converting Industry 4.0 applications—a secure investment in the future.

Sensorik

4.0

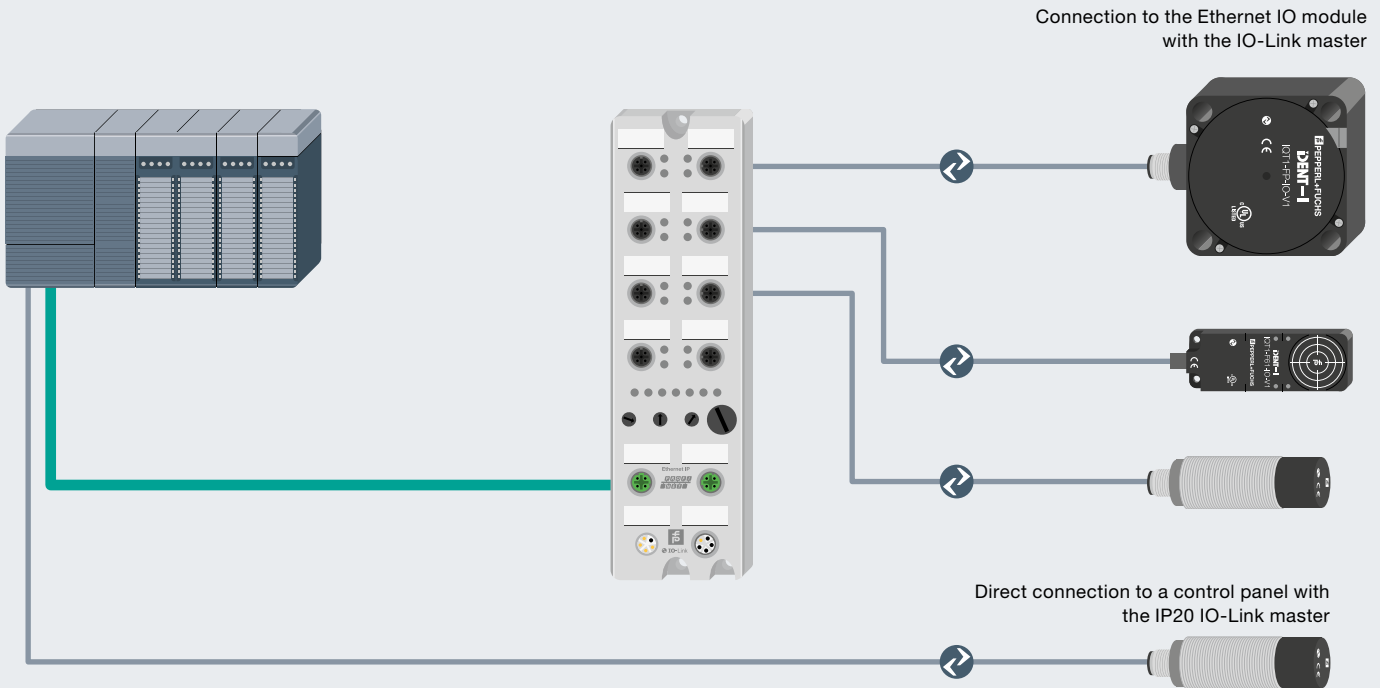

Alongside the IDENTControl family, Pepperl+Fuchs offers an optimized complete solution for applications that use IO-Link technology. The Ethernet IO module with an integrated IO-Link master enables all read/write heads to be connected to the IO-Link interface in a simple and cost-effective manner, providing a future-proof identification solution.



Simple Connection of IO-Link Read/Write Heads

The standard IO-Link can be used with devices from any manufacturer and makes full use of sensor intelligence. For this reason, Pepperl+Fuchs offers an Ethernet IO module with an integrated IO-Link master for connecting RFID IO-Link devices in the most efficient way possible. For example, these modules can be used to connect up to eight read/write heads, thereby significantly reducing channel costs and enabling the most cost-effective solution.

Thanks to its multi-protocol capability, the module is able to communicate via the standard Ethernet protocols, such as PROFINET and EtherNet/IP. As a result, this innovative solution can even be used with a wide range of standard control panels without any complications. To reap the full benefits of this technology, a variety of additional components are available to complement the modules. When the modules are combined with the IO-Link read/write heads from Pepperl+Fuchs as well as suitable tags and connectivity solutions, the result is a highly efficient complete solution from a single source—perfectly tailored to the requirements of Industry 4.0.

Highlights

- Machine standardization through multiple protocols: all standard Ethernet communication protocols in a single module
- Integrated IO-Link master function for continuous diagnostics and configuration from the control panel down to the sensor/actuator level
- Decentralized logic function in the fieldbus module for autonomous functionality, independent from the control panel
- Extensive diagnostic options either on the device itself or via web server for greater transparency and increased process reliability

Excerpt of technical data	ICE1-8IOL-G60L-V1D
Number of I/O devices	4 IO-Link type A, 4 IO-Link type B
Interfaces	PROFINET, EtherNet/IP, IO-Link
Degree of protection	IP67
Dimensions	200 x 59.6 x 30.7 mm

LF Read/Write Heads

Highly Reliable at Short Distances

LF
125 kHz

Up to
10 cm



Powerful, interference-free technology, and total accuracy: these are the characteristics that set the LF read/write heads from Pepperl+Fuchs apart. With a wide range of versions and housing designs, we offer the perfect solution for every installation scenario. Devices are well-suited for both near-field applications in assembly and conveyor technology and demanding applications in the food industry.

Extensive Portfolio for Every Installation Scenario

Read/write heads with a low frequency range (125 kHz) are the perfect solution for applications involving an operating distance of 0 to 100 millimeters. Pepperl+Fuchs offers a complete portfolio of devices for such applications. These devices boast an impressively high level of reliability, even when used in metallic environments.

The wide variety of cylindrical and cubic designs are available in various sizes and housing designs and are guaranteed to bring more flexibility to any application. In addition, Pepperl+Fuchs offers a number of special designs that have been optimized to meet requirements specific to each industry.

The portfolio includes solutions such as cylindrical LF systems with an M18/30 thread, specially designed to be flush mounted on metal. The Varikont L[®], among others, is available in a cubic design and can be aligned in a variety of different ways.









The portfolio also contains devices specifically designed for the food industry, housed in stainless steel and resistant to cleaning agents (IP67/68/69K). Special designs tailor-made for use in warehousing and material handling are another highlight from this collection. These are perfect for installation along the sides of or between rollers in conveyor systems.

Typical Applications

- Assembly technology and material handling: use in metallic environments
- Warehousing and material handling: tray identification in roller conveyor systems
- Mechanical and plant engineering: machine access or protection against counterfeiting
- Manufacturing process: identification tasks in Kanban racking systems

Highlights

- Wide variety of housing designs (cubic/cylindrical) for optimal integration
- Smaller designs with minimal space requirements
- Extra-compact versions for flush mounting on metal
- Special designs optimized for integration into roller conveyor systems
- For demanding applications (e.g., in the food industry)

Excerpt of technical data	18GM	30GM	FP	FP7V4A	L2	F61	F90A	F97
Order designation	IPH-18GM-V1	IPH-30GM-V1	IPH-FP-V1	IPH-FP7V4A	IPH-L2-V1	IPH-F61-V1	IPH-F90A-V1	IPH-F97-V1
								
Typical read distance	1 mm to 50 mm	1 mm to 65 mm	0 mm to 100 mm	0 mm to 100 mm	1 mm to 75 mm	2 mm to 45 mm	3 mm to 90 mm	1 mm to 70 mm
Typical write distance	0 mm to 40 mm	1 mm to 55 mm	0 mm to 80 mm	0 mm to 80 mm	2 mm to 65 mm	2 mm to 35 mm	3 mm to 80 mm	1 mm to 58 mm
Dimensions	ø 18 x 66 mm	ø 30 x 66 mm	107 x 80 x 40 mm	103 x 80 x 40 mm	67 x 40 x 40 mm	80 x 28 x 12 mm	144 x 43 x 20 mm	540 x 50 x 34 mm
Degree of protection	IP67			IP69K	IP67			

LF Read/Write Head Applications

Efficient Control of Logistics Processes

Reliable Even at the Lowest Temperatures (1)

It must be possible to track products throughout the entire cold chain when handling perishable foods such as fish, meat, and fruit. To ensure end-to-end tracking, tags are affixed to transport containers and pallets, where they are read using RFID L2 read/write heads or inscribed with additional information if required. These devices guarantee an optimal read result, even at temperatures as low as $-25\text{ }^{\circ}\text{C}$. This ensures that the cold store process runs as efficiently as possible with high throughput volumes, and means that products stay fresh throughout.

Efficiently Controlled Material Redelivery (2)

Modern “push” manufacturing concepts featuring Kanban systems make planning for production demand simple, since manufactured parts are replenished automatically. This means, for instance, that it is possible to use small, versatile mounting units without interrupting the production process, as the necessary materials are redelivered in an efficient manner. For this purpose, the exceptionally flat read/write heads in the F61 series can be integrated into the mounting unit racks. When the raw material containers equipped with integrated tags are returned, the read/write heads are able to detect which materials are running low and can initiate the replenishment process early on.

Perfect for Quick Conveyor Systems (3)

In the warehousing and material handling industry, it is essential that products are assigned correctly, processed quickly, and packaged in the most efficient way during the commissioning stage. A track-and-trace solution offers the additional advantage of being able to locate deliveries at all times. In a warehouse, circulating containers are identified using RFID read/write heads from the F97 series, and the products found within these containers are monitored via a central system. These devices can be mounted on the side of the roller conveyors or integrated directly into the conveyors themselves. Once the devices are installed, passing containers can be reliably identified at all times by means of their tags, regardless of their positioning or condition.

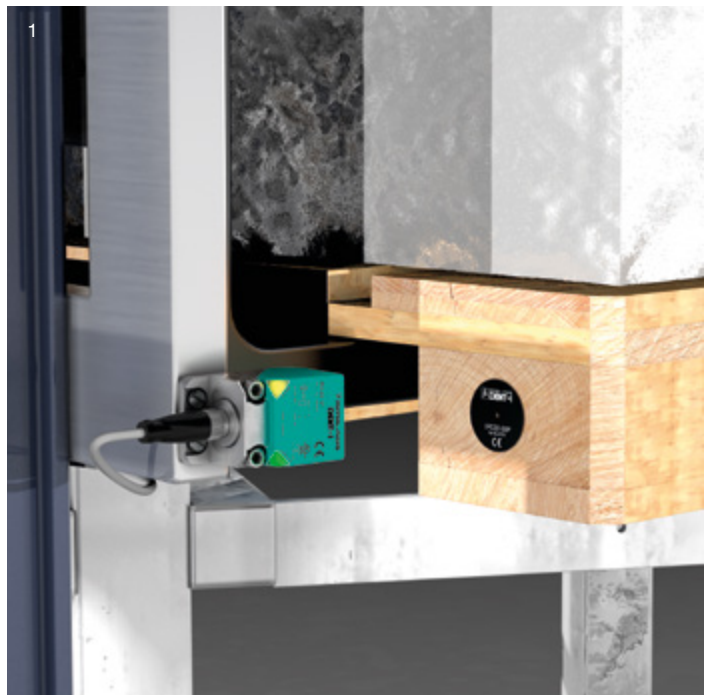
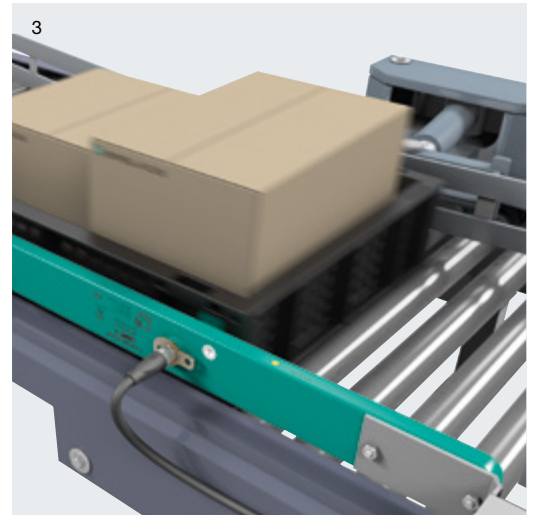

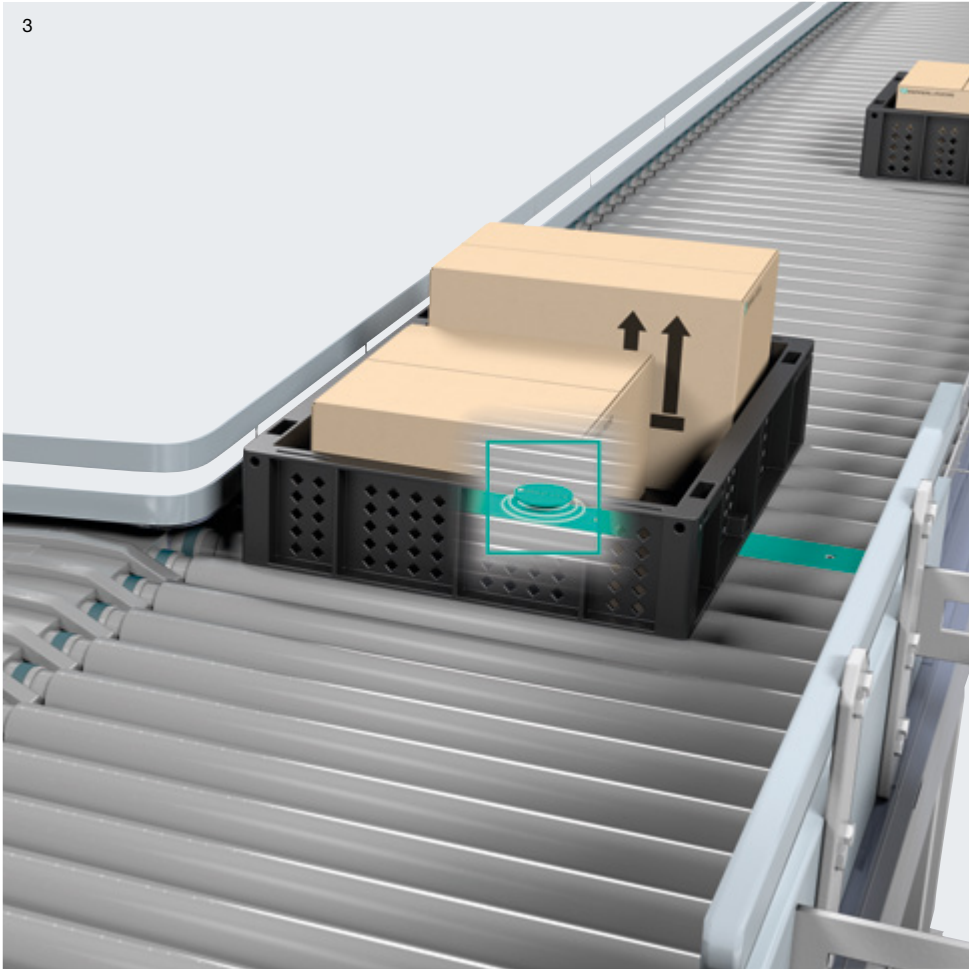

HF Read/Write Heads

Perfect for Large Amounts of Data and High Speeds

HF
13.56 MHz

Up to
15 cm



Applications in which large amounts of data are being transferred at high speeds really play to the strengths of HF read/write heads. For such applications, Pepperl+Fuchs offers a comprehensive range of devices in a wide variety of designs and housings. Perfect for every application and with a clear focus on the factory of the future, IO-Link technology provides the perfect foundation for establishing cross-hierarchical connectivity in line with Industry 4.0.

Designs Suited to Every Application

High-speed applications in which large amounts of data are being transferred call for read/write heads in the high frequency range (13.56 MHz). These read/write heads offer fully reliable read results in all near-field applications up to 15 centimeters, making them the ideal solution for identifying pallets and trays in material handling.

For these types of applications, Pepperl+Fuchs offers a wide variety of cylindrical and cubic designs in various sizes and housings. In addition, the portfolio includes versions designed for specific applications, such as the F198, whose ring-shaped design makes it perfectly tailored to the requirements of the tire industry.

Typical Applications





HF systems are ideal for handling large amounts of data at high speeds.

- Food and beverage industry: traceability of food products, pallet identification in cold stores
- Warehousing and material handling: object identification on monorail conveyors
- Mobile equipment: driver identification, detection of attachments, and protection of tool extensions

Another feature of this latest generation of HF RFID read/write heads is an IO-Link interface for connecting to all standard IO-Link masters. This interface provides the foundation for establishing cross-hierarchical connectivity in line with Industry 4.0.

Highlights

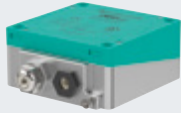
- IO-Link for Industry 4.0 applications
- Wide variety of housing designs (cubic and cylindrical) for optimal integration
- Smaller designs with minimal space requirements
- Extra-compact versions for flush mounting on metal
- Special designs optimized for the tire manufacturing industry
- Supports the global standard ISO 15693

Excerpt of technical data	18GM	FP	FP74VA	F61	F198
Order designation	IQH1-18GM-V1 IQT1-18GM-IO-V1 (IO-Link)	IQH1-FP-V1 IQT1-FP-IO-V1 (IO-Link)	IQH1-FP7V4A	IQH1-F61-V1 IQT1-F61-V1 (IO-Link)	IQH1-F198-V1 IQH1-F198-M-V1
					
Typical read distance	0 mm to 50 mm 0 mm to 55 mm (IO-Link)	0 mm to 130 mm	0 mm to 130 mm	0 mm to 55 mm	0 mm to 150 mm
Typical write distance	0 mm to 50 mm 0 mm to 55 mm (IO-Link)	0 mm to 130 mm	0 mm to 130 mm	0 mm to 55 mm	0 mm to 150 mm
Dimensions	ø 18 x 66 mm	113 x 80 x 40 mm	103 x 80 x 40 mm	80 x 28 x 12 mm	190.5 x 175 x 12 mm
Degree of protection	IP67	IP67	IP69K	IP67	IP67

HF Read/Write Head Applications

HF Read/Write Heads—Incredibly Versatile

Protection against Counterfeiting in Mechanical and Plant Engineering (1)

In the production of ceramic tiles, surfaces are processed and printed with various designs. To ensure the quality of the product, it is essential that only genuine print rollers are used, not less expensive replica components. The read/write heads in the 18GM series were developed for such a purpose, and can be integrated directly into the machine itself. Genuine parts can be clearly identified using a tag embedded in the print roller. As a result, it becomes impossible for replicas to be used, and the quality of the products is guaranteed in the long term. This provides a simple solution for monitoring the handling of spare parts, and makes it possible to plan maintenance cycles in the most efficient way possible.

Unique Identification in Monorail Conveyors (2)

In automotive production, RFID technology can be used in a variety of applications. In most cases, tags are integrated into skids and monorail conveyors on which parts or entire bodysells are transported from one production station to the next. The stations themselves are fitted with HF read/write heads such as those in the FP series, and these read/write heads identify all parts at a short distance and trigger the next step in production. The devices can be mounted directly onto metal and ensure that all manufactured products are located and assigned reliably.

Reliable Identification of Semifinished Products (3)

Cap strip machines are commonly used in the preproduction of vehicle tires. Their task is to coat steel filaments with a rubber mixture, gather several strips together, and wrap these strips around a bobbin. A tag is embedded in the bobbin for the purpose of reliably identifying strips. This tag can be located at any time, both during the loading of the cap strip machines and at various positions on a circular segment further along in the process. The ring-shaped F198 read/write head is perfectly suited to reading applications such as this. The coil can be mounted on the machine in such a way that the tag is always located within the sensing range, thereby guaranteeing a reliable process and ensuring that the semi-finished products can be tracked at all times.

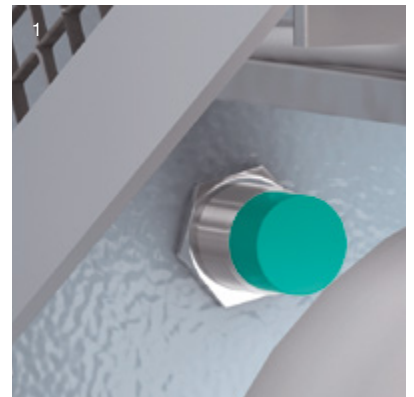

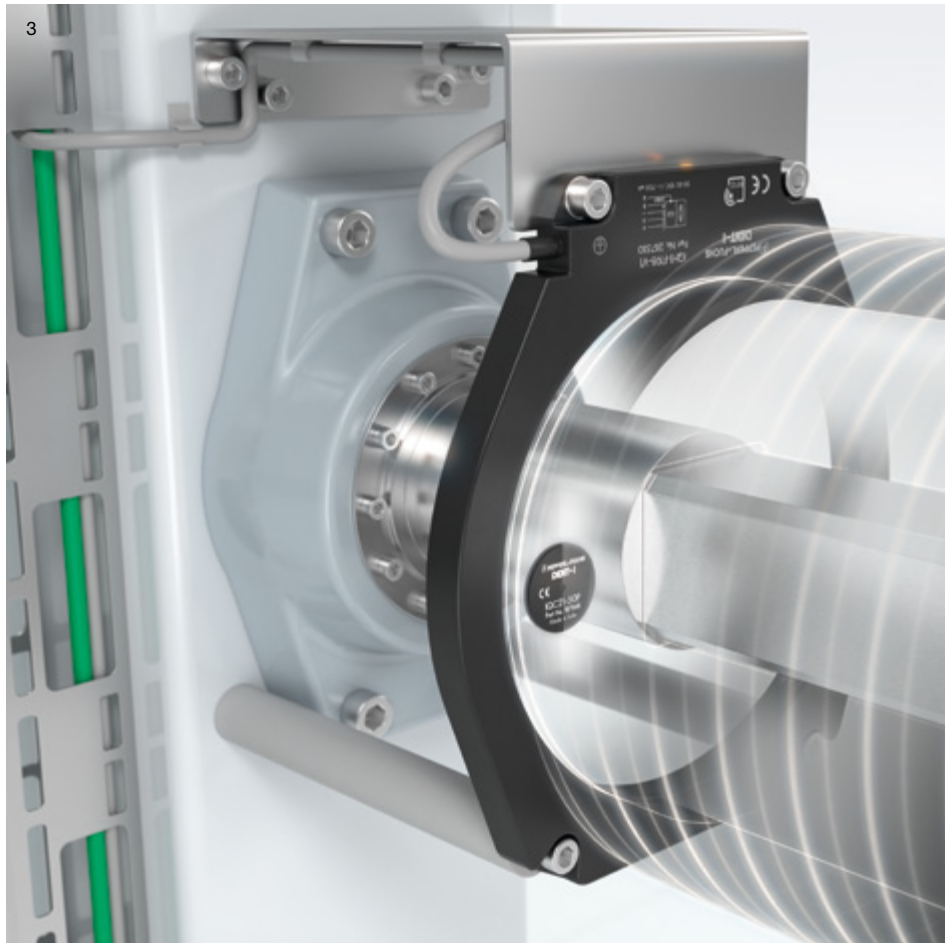

UHF Read/Write Heads

Maximum Performance for Global Use

UHF
865–928 MHz

Up to
6 m



Boasting incredible transparency, a high level of availability, and—most importantly—the possibility of being used anywhere in the world, the UHF read/write heads from Pepperl+Fuchs offer significant advantages for global companies in particular. Once all locations are equipped with products from the same series, system integration will be easier than ever and processes will become much more efficient.

High Level of Flexibility for Large Detection Ranges

The UHF systems (865–928 MHz) from Pepperl+Fuchs are the perfect choice for all far-field applications requiring detection ranges of up to 6 meters. Due to their compact design featuring an integrated antenna, these devices are equally ideal for use in confined spaces. Both series (F190 and F192) are available in the relevant frequency ranges for Europe, Asia, and the Americas, which is especially advantageous for global companies.

Depending on the application, the antenna polarization of the devices can be manually adjusted horizontally and vertically or switched automatically. This means that it is possible to adapt the device as closely as possible to a specific application without replacing the hardware, thereby ensuring that tags can be reliably identified and processes are kept free of interruption at all times.

Typical Applications



- Automotive industry: tag/label identification in car body manufacturing, painting lines, and final assembly
- Warehousing and material handling: bulk reading and identification of individual boxes, cardboard, etc.
- Vehicle identification at entrances or for monitoring access of people on premises

The read/write heads in both series are capable of reliably identifying multiple RFID tags in a single read operation. Information can therefore be transferred at a quicker rate, throughput times can be reduced, and the efficiency of manufacturing and logistics processes can be significantly increased.

Preassembled functional modules allow the devices to be integrated into systems more quickly, and preset parameters that are specific to each country make installation far simpler. The devices are compatible with the IDENTControl system family, which means that users have the option of expanding their own systems at any time with maximum flexibility.

Highlights

- For medium to large detection ranges and global use
- Preassembled functional modules for quick and simple system integration
- Compact, durable housing with a wide range of applications
- Switchable antenna polarization for accurate tag identification and reliable process flows
- Multitag reading for maximum productivity

Excerpt of technical data	F190	F192
Order designation	IUH-F190* IUT-F190*	IUH-F192-V1-FR1 (Europe, Middle East, Africa) IUH-F192-V1-FR2 (Asia, Americas [excluding Canada, USA, Mexico]) IUH-F192-V1-FR2-02 (Canada, USA, Mexico)
		
Frequency range	UHF 865–928 MHz	UHF 865–928 MHz
Typical operating distance	2 m	6 m
Dimensions	114 x 112 x 63 mm	270 x 268 x 81 mm
Degree of protection	IP67	

UHF Read/Write Head Applications

UHF Technology for Efficient Processes

Read/Write Heads for the Automotive Industry (1)

Production reliability and productivity are two of the main challenges facing the automotive industry. Since a great number of production steps take place at the same time in a confined space, there is a demand for devices with individually adjustable read ranges that do not suffer from cross-talk. Furthermore, the write function makes it possible to modify the tag information for downstream production steps.

The read/write heads used for this application control factors such as the design of the bodies, taking into account all of the parts required for the model. The read/write heads receive the necessary information relating to the model, colors, seats, and tires via the tags, and guide the bodysHELLs on their skids to the right station via their control system. The F190 from Pepperl+Fuchs is particularly suited for use in bodysHELL production. This device performs impressively when completing tasks requiring a medium detection range and is also ideal for use in confined spaces with its compact design. In contrast, the F192 is primarily designed for use in applications that require a larger detection range, such as in the final assembly stage, at the test bench, and on hall doors.

Bulk Detection with UHF at Large Distances (2)

In logistics, products need to reach their destination quickly and reliably without any allocation errors. The F190 from Pepperl+Fuchs is perfectly designed to tackle any application involving a read distance of 1 to 2 meters. In a single bulk reading, the devices are capable of detecting data with total accuracy, ensuring maximum efficiency across all processes. The F192 UHF read/write head is the perfect choice for applications that require read distances of more than 2 meters. The device boasts a detection range of up to 6 meters and can read and write multiple tags at the same time, making it possible to achieve an exceptionally quick throughput and speed up processes considerably.



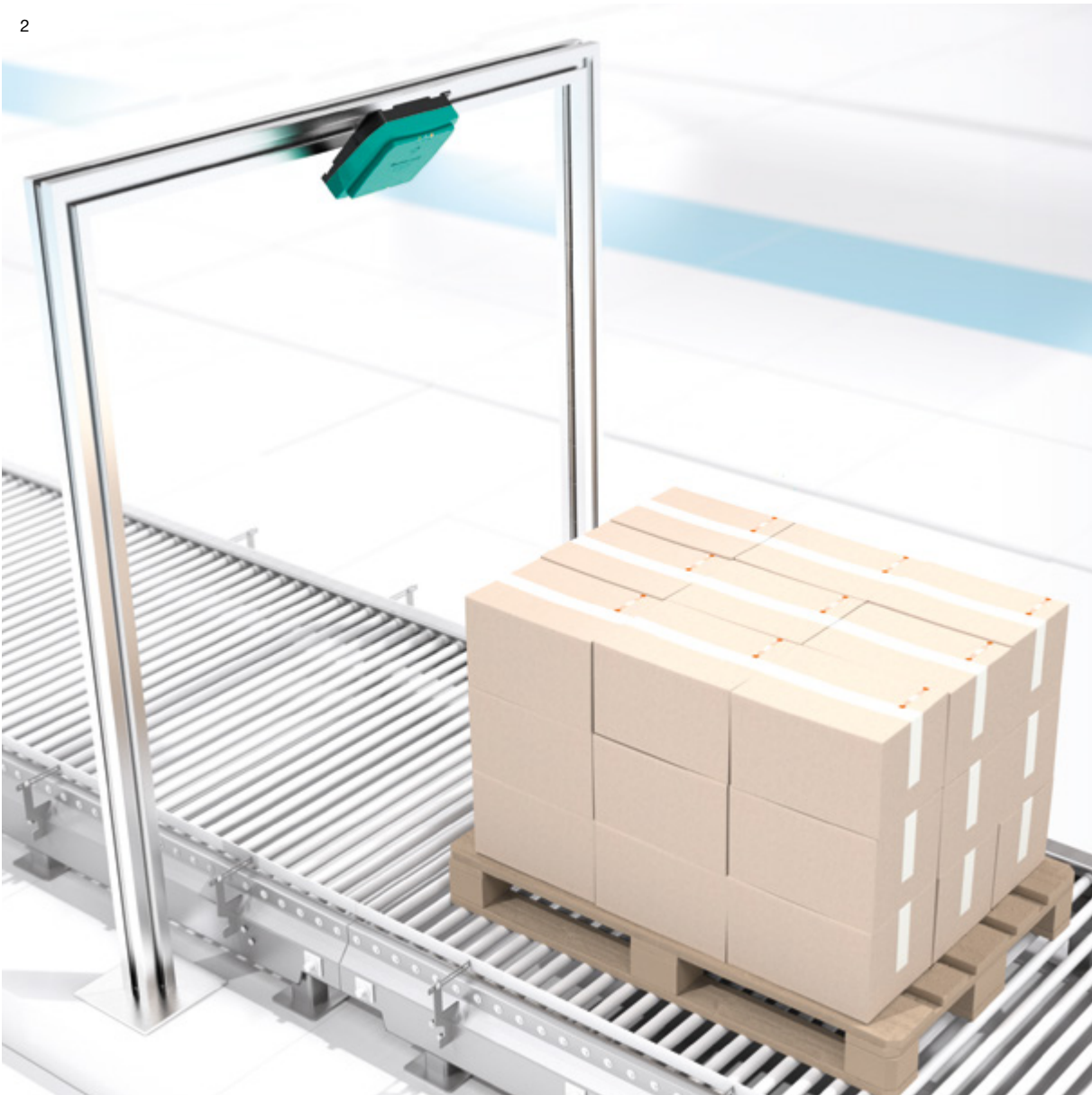
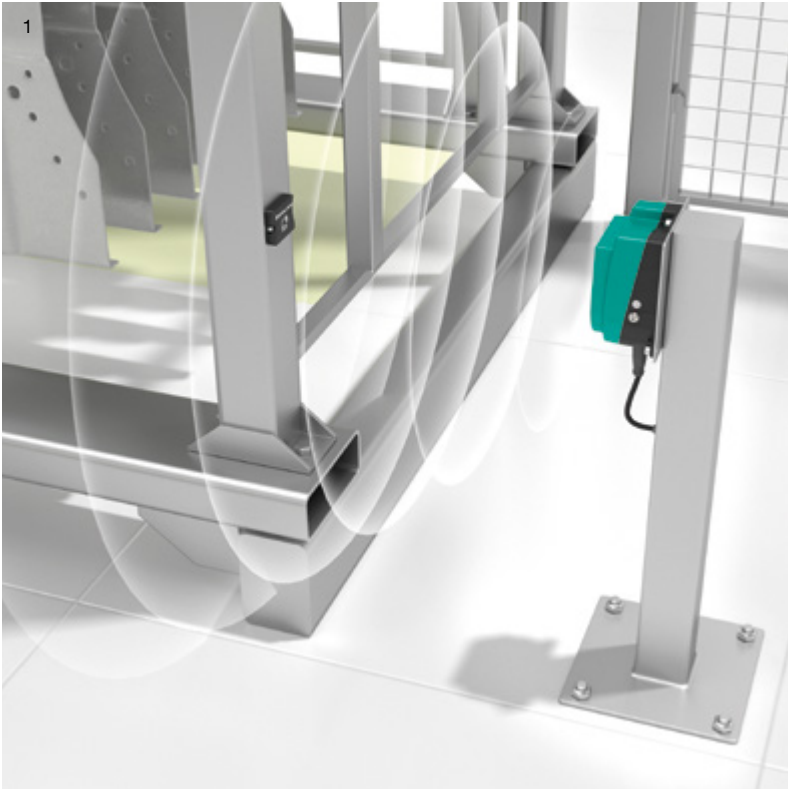

Tags

Versatility for Any Environment



Having important identification data available is crucial for ensuring a reliable and efficient process. Achieving this requires tags that operate with complete accuracy, anytime and anywhere. To handle such a task, Pepperl+Fuchs offers tags with the ideal frequency range, memory size, and design for all applications.

Powerful and Able to Withstand the Conditions of Any Environment

Tags carry important information that is vital for ensuring a smooth, reliable process flow. Pepperl+Fuchs offers a comprehensive portfolio of tags that have been optimized for industrial applications. The portfolio encompasses all frequency ranges as well as various memory sizes, designs, and mounting styles, thereby perfectly covering the broad spectrum of application requirements.

In addition to special labels printed on metal, cost-optimized paper or plastic labels are available. The range even includes extremely durable designs for mechanically or thermally demanding environments, such as high-temperature applications. These include tags that are resistant to oils, fuels, cleaning agents, and a variety of chemicals.

The application experts at Pepperl+Fuchs will help you choose the perfect read/write tag to ensure your RFID system solution delivers powerful performance. Customers have the additional option of requesting for their tags to be tailored to their specific requirements.

Highlights

- Expert advice when choosing the most powerful tag for your application
- Comprehensive portfolio of RFID tags for LF, HF, and UHF frequency ranges
- Especially small tags that can be mounted in metal to extremely robust, thermally or chemically resistant versions

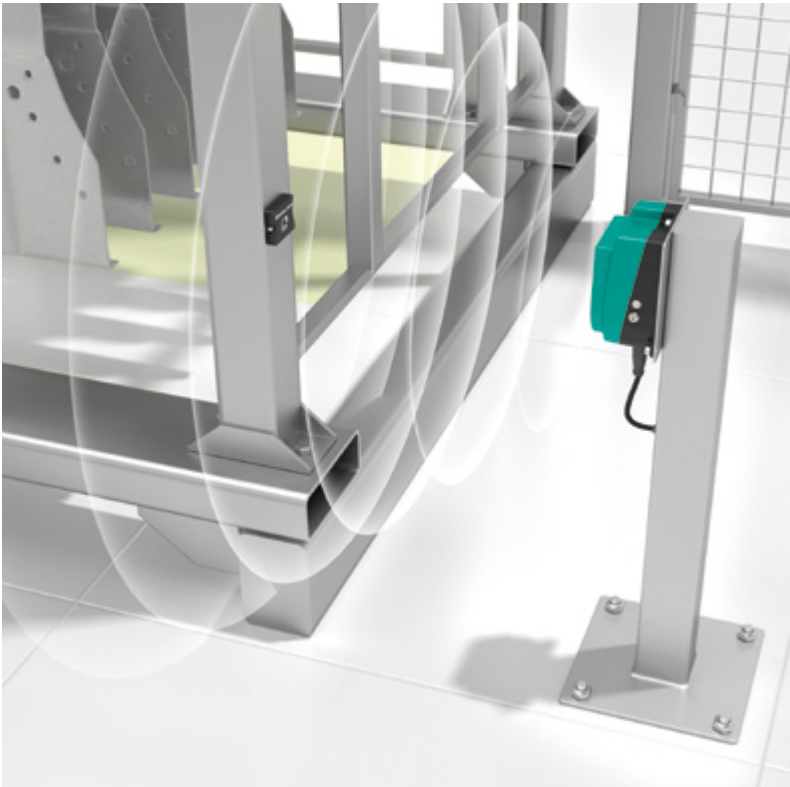
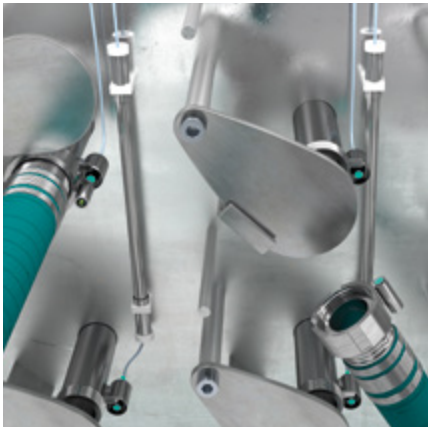
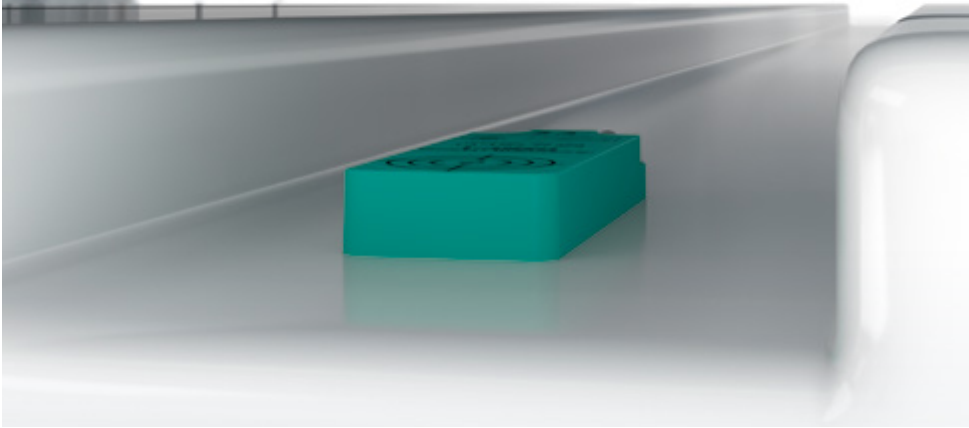
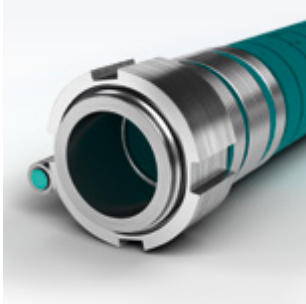
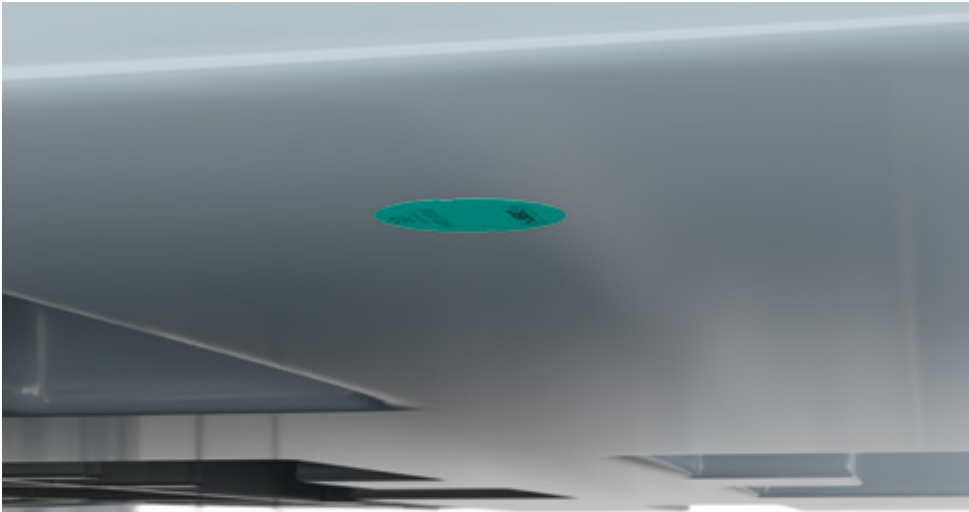

Handhelds

High Level of Flexibility for Mobile Use



Along with its stationary RFID systems, Pepperl+Fuchs offers powerful RFID handhelds for a wide range of mobile identification tasks. These devices are available in all frequency ranges and are synonymous with flexible data collection. Furthermore, customizable software enables perfect integration into customer-specific processes.

Durable, Efficient, and Tailor-Made

Manual quality control and several other tasks in the process flow require the use of mobile devices for identifying and editing tags. RFID handhelds from Pepperl+Fuchs are the perfect solution for such applications, since they are suited to any application and can be used in all frequency ranges.

The standard software that accompanies the devices offers a wide range of powerful, highly efficient features, such as the option to write multiple tags using a batch file. In addition, a functional module can be integrated into the devices to allow you to establish a direct connection to the control panel for the purpose of transferring data.

Customer-specific software solutions are available to allow the devices to be adapted to match individual application requirements as closely as possible. Thanks to their robust design, the handhelds are resistant to challenging ambient conditions and are perfectly suited for both indoor and outdoor use.

Highlights

- Software can be tailored to individual identification tasks as required
- Functional module for connecting directly to the control panel
- Robust design for indoor and outdoor use
- Quick, reliable identification for a high level of productivity
- Standard software with powerful features (e.g., write tags using a batch file)



LF and HF Handhelds—HH27 Series

These devices are equipped with powerful, integrated LF or HF read/write heads, and are incredibly easy to use with a keypad for entering alphanumeric characters and a large touch display. The 3.5" TFT color display with an LED backlight ensures readability, even in poor lighting.

The devices are available with WLAN, Bluetooth, and Windows Embedded CE 6.0. Their preinstalled standard software offers a range of powerful features, and the function keys can be programmed to the specific requirements of the customer. The handhelds are fitted with a housing with an IP43 rating, and can be used at ambient temperatures between 0 °C and 45 °C. The comprehensive range of accessories includes a charger, docking station, and batteries.



UHF RFID Handhelds—HH41, HH42, HH43 Series

Thanks to their powerful UHF read/write heads, these RFID handhelds are perfectly suited for reading multiple tags. Extra-sharp displays ensure readability, even in poor lighting, and the devices are equipped with a 2-D imager as an additional feature.

The standard software, which is available free of charge, offers a range of intelligent features, while the freely programmable function keys ensure that the device can be perfectly adapted to the customer's specific applications. The handhelds are fitted with a sturdy housing with an IP54 rating, and can be used at ambient temperatures between -20 °C and +55 °C. The comprehensive range of accessories includes a charger, docking station, and batteries.

Excerpt of technical data	HH27		HH41	HH43	HH42
Order designation	IPT-HH27	IQT1-HH27	IUT-HH41	IUT-HH43	IUT-HH42
Operating frequency	125 kHz	13.65 MHz	FR1-01: 865–868 MHz (EU) FR2-02: 902–928 MHz (US) FR2-03: 920–925 MHz (CHN)		
Degree of protection	IP43		IP54		
Dimensions	224 x 88 x 49 mm		250 x 90 x 47 mm	250 x 105 x 175 mm	147 x 80 x 39 mm
Interface	Physical: USB and Ethernet via charger (accessory) Wireless connection: WLAN IEEE 802.11 a/b/g, Bluetooth 2.0 + EDR		Physical: USB and Ethernet via charger (accessory) Wireless connection: WLAN 802.11 a/b/g, WPA2 Bluetooth 2.0 + EDR Class 2		Physical: USB and Ethernet via charger (accessory) Wireless connection: WLAN 802.11 a/b/g, WPA2 Bluetooth 2.1 + EDR Class 2

Customizable Software for Greater Flexibility

The RFID handhelds feature preinstalled standard software with a wide range of helpful functions.

In addition, you will receive a software solution from Pepperl+Fuchs that is specially tailored to your individual application to ensure your device can be integrated as effectively as possible.

For more information, visit:
www.pepperl-fuchs.com/RFID

Devices for Hazardous Areas

Reliable Identification in Hazardous Areas

Introducing the perfect addition to the extensive portfolio of high-performance identification solutions from Pepperl+Fuchs: the Ident-Ex® 01 handheld from ecom for use in hazardous areas. A pioneer in mobile devices that are specially developed for this area, ecom is always looking for new ways to increase efficiency and productivity with long-lasting effects.



Intrinsically Safe Ident-Ex® 01 Handheld—Efficient and Versatile

In hazardous areas, collecting data can pose a serious challenge. The products offered by ecom include an intrinsically safe Ident-Ex® barcode scanner and RFID reader for performing demanding scanning tasks and 12-hour shifts in a simple and highly efficient process.

Thanks to its modular design, this sturdy handheld can be perfectly adapted to the specific requirements of various identification tasks. Several powerful head modules are available, and can be replaced at an ecom service center as necessary. In addition, the Ident-Ex® 01 can be paired with ecom smartphones and tablets, and all other mobile devices, via Bluetooth connection.

Series	Ident-Ex® 01
Order designation	
Scanning performance	RFID ¹ : up to 1.5 m Barcode: 15 cm to 15 m
RFID operating frequency	LF 125/134 kHz HF 13.56 MHz UHF 868 MHz UHF 915 MHz
Barcode operating frequency	2-D multi-range barcode imager 1-D laser scanner (additionally available as a combination of RFID and 1-D)
Bluetooth	Class II, up to approx. 10 meters
Dimensions	With Ex-25 head module: 235 x 84 x 58 mm Other head modules: 221 x 84 x 58 mm

Excerpt of technical data. The approval for explosion-hazardous areas can be found on our website.

¹ Dependent on scan tag and surroundings

Highlights

- Extra-sturdy and intrinsically safe
- High level of flexibility through interchangeable head modules
- Easy to operate with one hand
- Suitable for pairing with any Bluetooth device
- Ideal for intensive scanning tasks and 12-hour shifts
- Optional: service level agreement over three years (SLA)



Modular Read Heads for Individual Configuration

The unique modular concept of the Ident-Ex® 01 allows the customer to choose between various read head modules, enabling the handheld to be configured to suit customer-specific applications as closely as possible. Should the customer's application requirements change, the module on the unit can be replaced or supplemented by the ecom service center at any time.

One of the options available is a classic 1-D barcode laser scanner with a high motion tolerance and RFID technology for LF, HF, and UHF frequency ranges. A 2-D multi-range imager is also available. Additional interchangeable modules allow RFID and 1-D scanners to be combined. This yields a modular system that combines state-of-the-art close- and long-range scan technology in a single device.

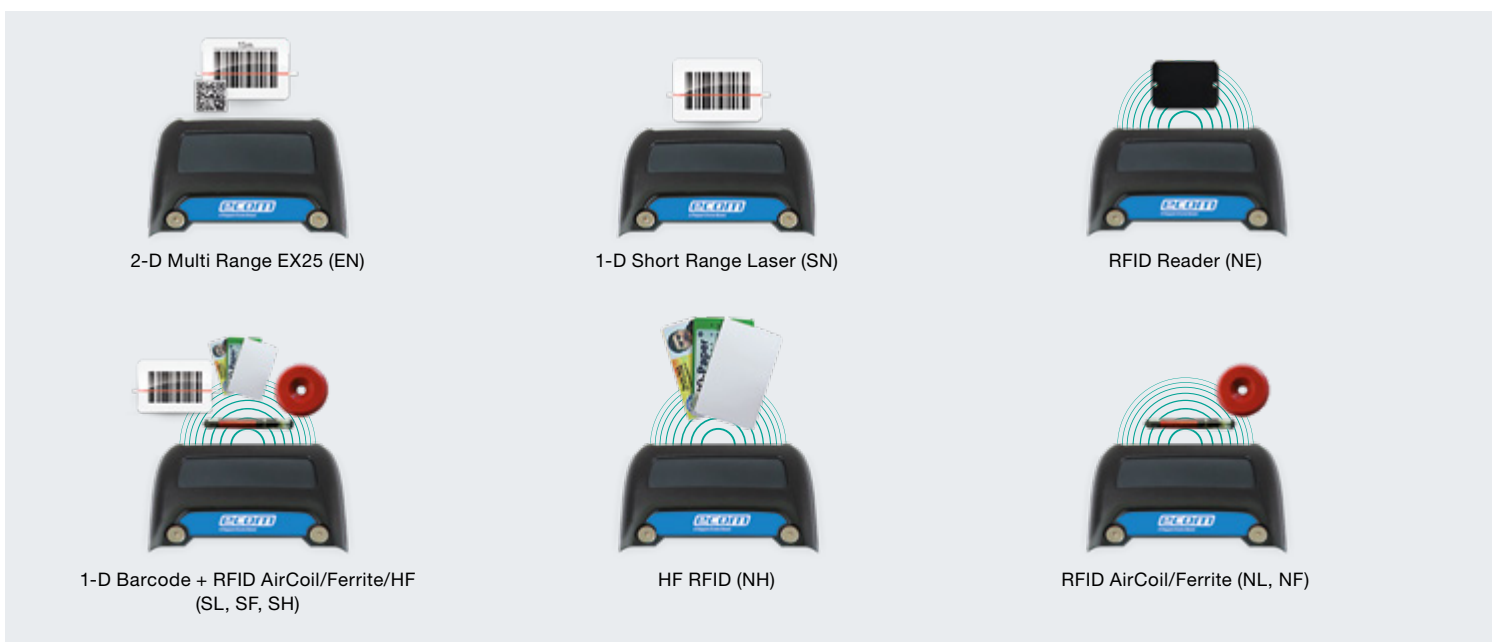

Configure your Ident-Ex® 01 here:
www.pepperl-fuchs.com/ecom-configurator

Your automation, our passion.

Explosion Protection

- Intrinsic Safety Barriers
- Signal Conditioners
- FieldConnex® Fieldbus
- Remote I/O Systems
- Electrical Ex Equipment
- Purge and Pressurization
- Industrial HMI
- Mobile Computing and Communications
- HART Interface Solutions
- Surge Protection
- Wireless Solutions
- Level Measurement

Industrial Sensors

- Proximity Sensors
- Photoelectric Sensors
- Industrial Vision
- Ultrasonic Sensors
- Rotary Encoders
- Positioning Systems
- Inclination and Acceleration Sensors
- Fieldbus Modules
- AS-Interface
- Identification Systems
- Displays and Signal Processing
- Connectivity

Pepperl+Fuchs Quality

Download our latest policy here:

www.pepperl-fuchs.com/quality

